

## 32M-BIT MASK ROM (16/32 BIT OUTPUT)

### FEATURES

- Bit organization
  - 2M x 16 (word mode)
  - 1M x 32 (double word mode)
- Fast access time
  - Random access: 100ns (max.)
  - Page access: 30ns (max.)
- Page
  - 8 double words per page
- Current
  - Operating: 60mA
  - Standby: 50uA
- Supply voltage
  - 3.3V±10%
- Package
  - 70 pin SSOP (500mil)

### PIN CONFIGURATION

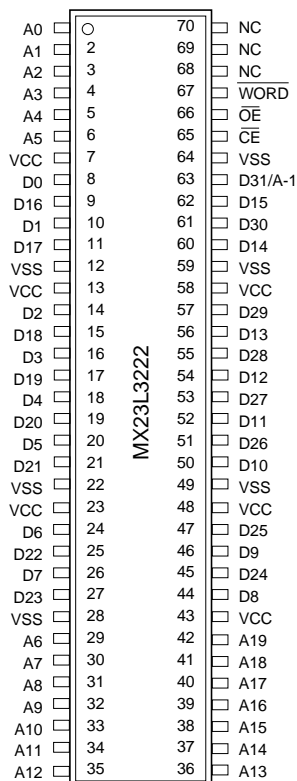

### PIN DESCRIPTION

Symbol	Pin Function
A0~A19	Address Inputs
D0~D30	Data Outputs
D31/A-1	D15 (Word Mode)/ LSB Address (Byte Mode)
CE	Chip Enable Input
OE	Output Enable Input
WORD	Double Word/ Word Mode Selection
VCC	Power Supply Pin
VSS	Ground Pin
NC	No Connection

### ORDER INFORMATION

Part No.	Access	Page Access	Package
	Time	Time	
MX23L3222MC-10	100ns	30ns	70 pin SSOP
MX23L3222MC-12	120ns	45ns	70 pin SSOP

**MODE SELECTION**

$\overline{CE}$	$\overline{OE}$	$\overline{WORD}$	D31/A-1	D0~D15	D16~D31	Mode	Power
H	X	X	X	High Z	High Z	-	Stand-by
L	H	X	X	High Z	High Z	-	Active
L	L	H	Output	D0~D15	D16~D31	Double Word	Active
L	L	L	Input	D0~D15	High Z	Word	Active

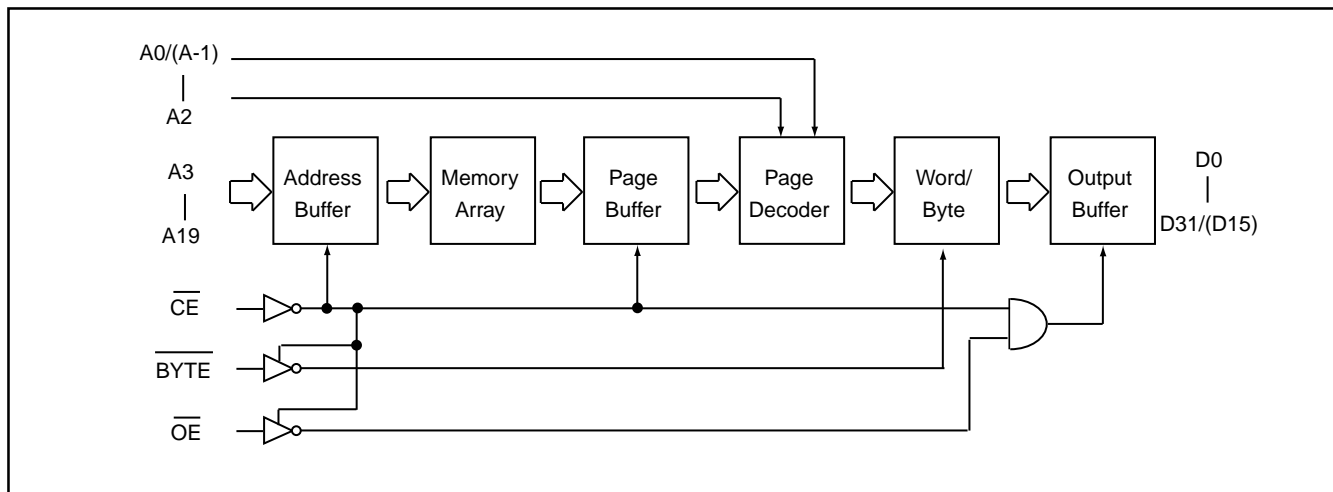
**BLOCK DIAGRAM**

**ABSOLUTE MAXIMUM RATINGS**

Item	Symbol	Ratings
Voltage on any Pin Relative to VSS	VIN	-1.3V to VCC+2.0V (Note)
Ambient Operating Temperature	Topr	0°C to 70°C
Storage Temperature	Tstg	-65°C to 125°C

Note: Minimum DC voltage on input or I/O pins is -0.5V. During voltage transitions, inputs may undershoot VSS to -1.3V for periods of up to 20ns. Maximum DC voltage on input or I/O pins is VCC+0.5V. During voltage transitions, input may overshoot VCC to VCC+2.0V for periods of up to 20ns.

**DC CHARACTERISTICS** (Ta = 0°C ~ 70°C, VCC = 3.3V±10%)

Item	Symbol	MIN.	MAX.	Conditions
Output High Voltage	VOH	2.4V	-	IOH = -0.4mA
Output Low Voltage	VOL	-	0.4V	IOL = 1.6mA
Input High Voltage	VIH	2.2V	VCC+0.3V	
Input Low Voltage	VIL	-0.3V	0.8V	
Input Leakage Current	ILI	-	5uA	0V, VCC
Output Leakage Current	ILO	-	5uA	0V, VCC
Operating Current	ICC1	-	60mA	tRC = 100ns, all output open
Standby Current (TTL)	ISTB1	-	1mA	$\overline{CE} = VIH$
Standby Current (CMOS)	ISTB2	-	50uA	$\overline{CE} > VCC - 0.2V$
Input Capacitance	CIN	-	10pF	Ta = 25°C, f = 1MHZ
Output Capacitance	COUT	-	10pF	Ta = 25°C, f = 1MHZ

**AC CHARACTERISTICS** (Ta = 0°C ~ 70°C, VCC = 3.3V±10%)

Item	Symbol	23L3222-10		23L3222-12	
		MIN.	MAX.	MIN.	MAX.
Read Cycle Time	tRC	100ns	-	120ns	-
Address Access Time	tAA	-	100ns	-	120ns
Chip Enable Access Time	tACE	-	30ns	-	45ns
Page Mode Access Time	tPA	-	30ns	-	45ns
Output Enable Time	tOE	-	30ns	-	45ns
Output Hold After Address	tOH	0ns	-	0ns	-
Output High Z Delay	tHZ	-	20ns	-	20ns

Note: Output high-impedance delay (tHZ) is measured from  $\overline{OE}$  or  $\overline{CE}$  going high, and this parameter guaranteed by design over the full voltage and temperature operating range - not tested.

## AC Test Conditions

Input Pulse Levels	0.4V~ 2.4V
Input Rise and Fall Times	10ns
Input Timing Level	1.5V
Output Timing Level	0.8V and 2.0V
Output Load	See Figure

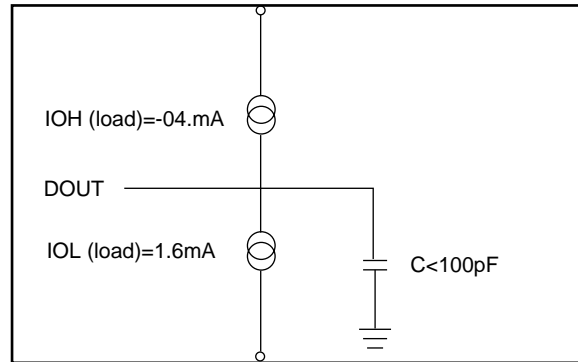

Note: No output loading is present in tester load board.

Active loading is used and under software programming control.

Output loading capacitance includes load board's and all stray capacitance.

## TIMING DIAGRAM

### RANDOM READ

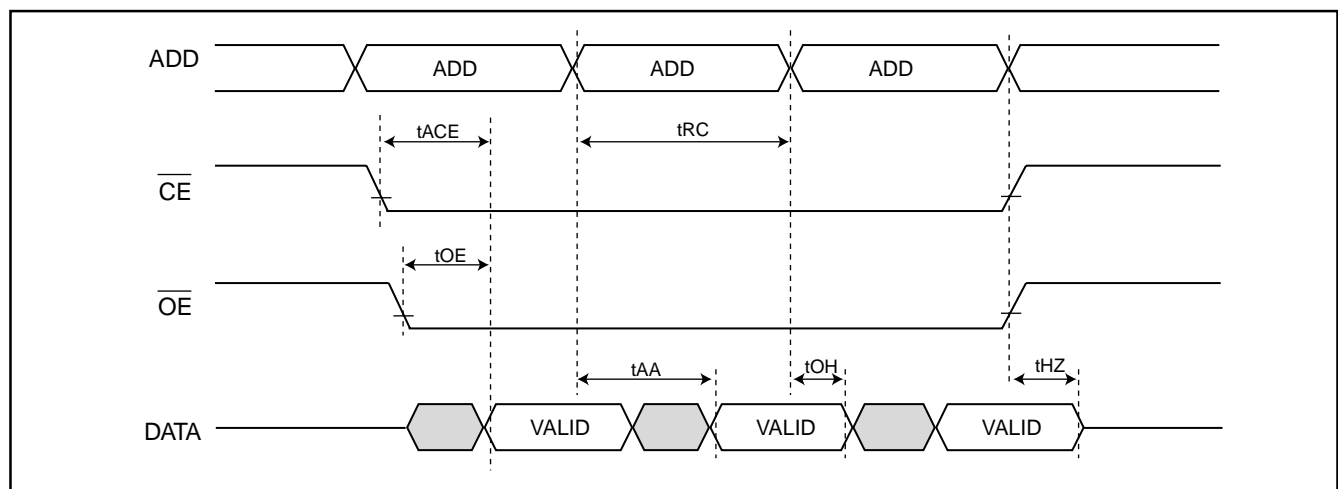

### PAGE READ

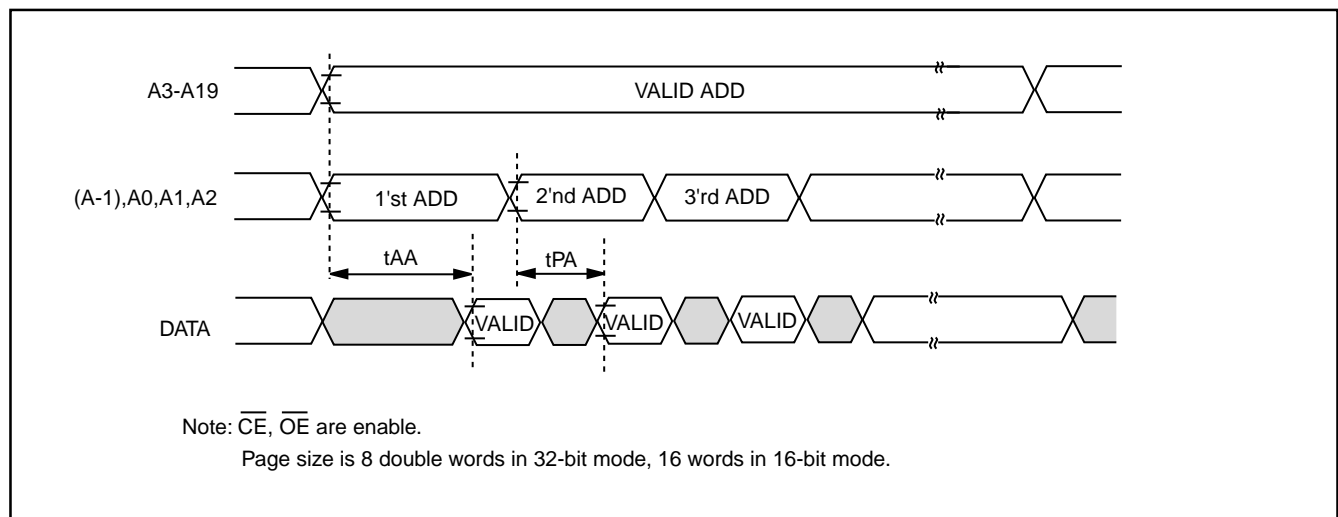

**REVISION HISTORY**

<b>Revision</b>	<b>Description</b>	<b>Page</b>	<b>Date</b>
1.8	AC Characteristics: The page mode access time (tPA) and output enable time (tOE) are changed as 45ns instead of 50ns. Added 100ns speed grade. Package: Added 100 pin TQFP package, dimension is 14mm x 14mm x 1mm.		MAR/25/1998
1.9	AC CHARACTERISTICS tOH 10ns-->0ns	P3	JAN/29/1999
2.0	Delete package:100-pin TQFP	P1,2	OCT/19/2001



**MX23L3222**

---

---

**MACRONIX INTERNATIONAL Co., LTD.**

**HEADQUARTERS:**

TEL:+886-3-578-6688

FAX:+886-3-563-2888

**EUROPE OFFICE:**

TEL:+32-2-456-8020

FAX:+32-2-456-8021

**JAPAN OFFICE:**

TEL:+81-44-246-9100

FAX:+81-44-246-9105

**SINGAPORE OFFICE:**

TEL:+65-348-8385

FAX:+65-348-8096

**TAIPEI OFFICE:**

TEL:+886-2-2509-3300

FAX:+886-2-2509-2200

**MACRONIX AMERICA, INC.**

TEL:+1-408-453-8088

FAX:+1-408-453-8488

**CHICAGO OFFICE:**

TEL:+1-847-963-1900

FAX:+1-847-963-1909

**[http : //www.macronix.com](http://www.macronix.com)**