

AN5192K

Single chip IC with I²C bus Interface for PAL/NTSC color TV system

■ Overview

The AN5192K is a single chip IC for PAL/NTSC system color TV. TV for multiple systems can be easily designed by the use of this IC in combination with SECAM demodulation IC (The AN 5637).

■ Features

- Free of mechanical adjustment
Built-in I²C bus interface eliminates the need for mechanical adjustment
- Rationalization of external components
Built-in chroma trap and BPF reduce the external components

■ Applications

- TV, TV with VCR

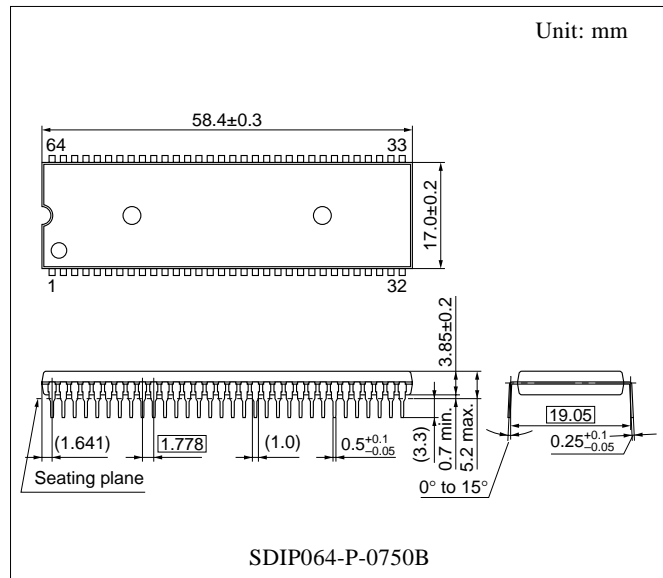

■ Block Diagram

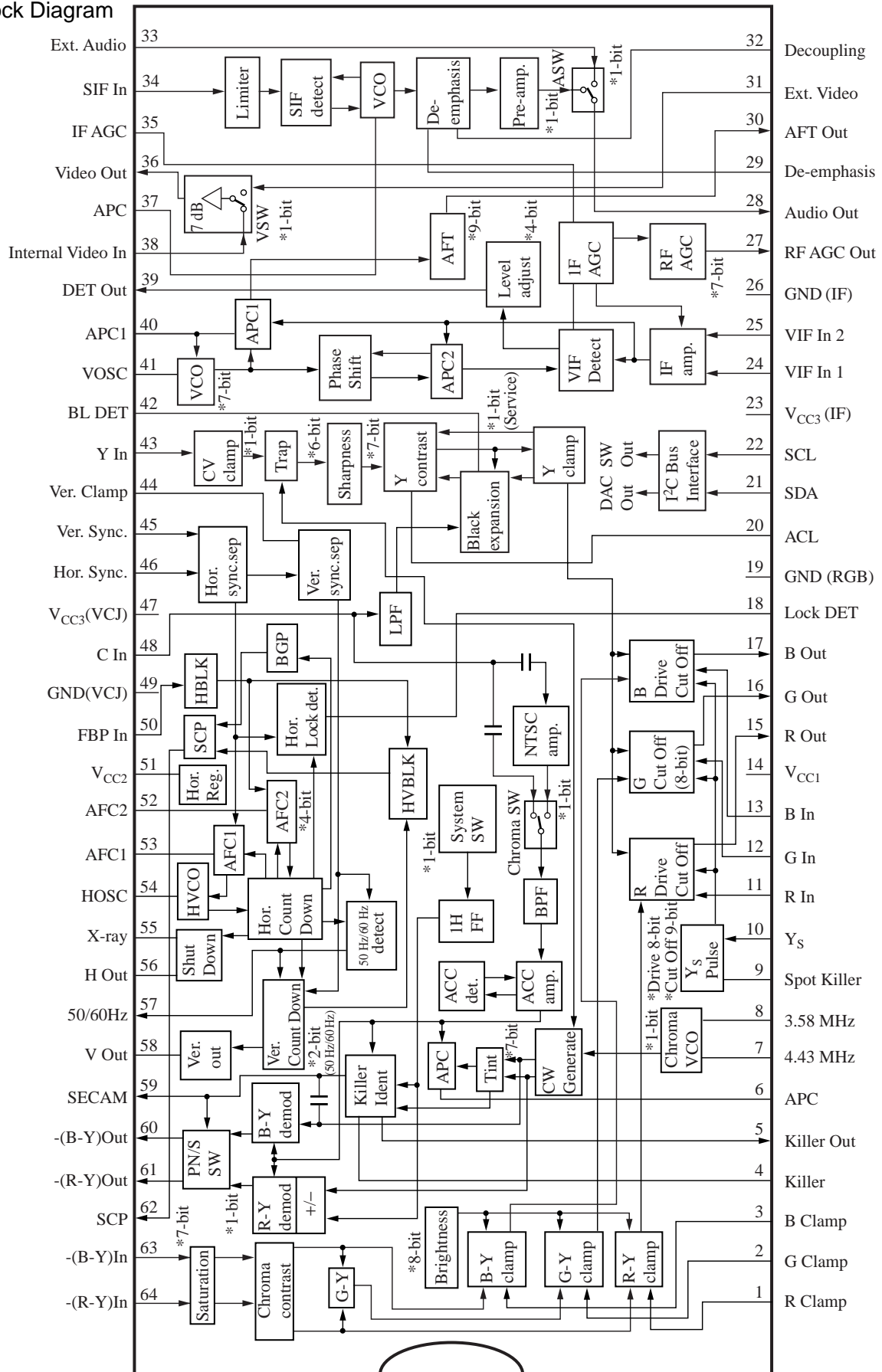

■ Pin Description

Pin No.	Description	Pin No.	Description
1	(R-Y) Clamp	33	External Audio Input
2	(G-Y) Clamp	34	SIF Input/DAC Output
3	(B-Y) Clamp	35	IF AGC Filter
4	Killer Filter	36	Video Output
5	Killer Output	37	SIF APC Filter
6	Chroma APC Filter	38	Internal Video Input
7	Chroma VCO (4.43 MHz)	39	VIF Detect Output
8	Chroma VCO (3.58 MHz)	40	VIF APC1 Filter
9	Spot Killer	41	VIF VCO ($f_p/2$)
10	Ys Input (Fast blanking)	42	Black Level Det./Blank off SW
11	External R Input	43	Y Input
12	External G Input	44	Ver.Sync.Clamp
13	External B Input	45	Ver.Sync.Input
14	V _{CC1}	46	Hor.Sync.Input
15	R Output	47	V _{CC3-2} (Chroma/Jungle/DAC)
16	G Output	48	Chroma Input/Black Expansion Start
17	B Output	49	GND (Video/Chroma/Jungle)
18	Hor.Lock Detect	50	FBP Input
19	GND (RGB/I ² C/DAC)	51	V _{CC2} (Hor.Stability Supply)
20	ACL	52	AFC2 Filter
21	SDA	53	AFC1 Filter
22	SCL	54	Hor.VCO (32 f _H)
23	V _{CC3-1} (VIF/SIF)	55	X-ray Protection Input
24	VIF Input 1	56	Hor.Pulse Output
25	VIF Input 2	57	50 Hz/60 Hz Detect Output
26	GND (VIF/SIF)	58	Ver. Pulse Output
27	RF AGC Output	59	SECAM Interface
28	Audio Output	60	-(B-Y) Output
29	De-emphasis	61	-(R-Y) Output
30	AFT Output	62	Sandcastle Pulse Output
31	External Video Input	63	-(B-Y) Input
32	DC Decoupling Filter	64	-(R-Y) Input

■ Absolute Maximum Ratings

Parameter	Symbol	Rating		Unit
Supply voltage	V_{CC}	V_{CC1} (14)	10.5	V
		V_{CC3} (23, 47)	6.0	
Supply current	I_{CC}	I_{14}	77	mA
		I_{23+47}	119	
		I_{51}	27	
Power dissipation *2	P_D	1 372		mW
Operating ambient temperature *1	T_{opr}	-20 to +70		°C
Storage temperature *1	T_{stg}	-55 to +150		°C

Note) *1: Except for the operating ambient temperature and storage temperature, all ratings are for $T_a = 25^\circ\text{C}$.

*2: The power dissipation shown is the value for $T_a = 70^\circ\text{C}$.

■ Recommended Operating Range

Parameter	Symbol	Range	Unit
Supply voltage	V_{CC1}	8.1 to 9.9	V
Supply voltage	V_{CC3}	4.5 to 5.5	V
Supply current	I_{51}	10 to 25	mA

■ Electrical Characteristics at $T_a = 25^\circ\text{C}$

Parameter	Symbol	Conditions	Min	Typ	Max	Unit
Power supply (DAC Data are typical)						
Supply current 1	I_{14}	Current at $V_{14} = 9\text{ V}$	44	55	66	mA
Supply current 2	I_{23}	Current at $V_{23} = 5\text{ V}$	8	11	14	mA
Supply current 3	I_{47}	Current at $V_{47} = 5\text{ V}$	56	71	85	mA
Stabilized power supply voltage	V_{51}	Voltage at $I_{51} = 15\text{ mA}$	5.8	6.5	7.2	V
Stabilized power supply current	I_{51}	Current at $V_{51} = 5\text{ V}$	2	5	7	mA
Stabilized power supply input resistance	R_{51}	DC measurement Gradient between $I_{51} = 10\text{ mA}$ and 25 mA	1	5	10	Ω
VIF circuit (Typical input $f_p = 38.9\text{ MHz}$, $V_{IN} = 90\text{ dB}\mu$, DAC Data are typical)						
Video detection output (typ.)	V_{PO}	Modulation $m = 87.5\%$ Data 0A = 88	1.75	2.1	2.5	V[p-p]
Video detection output (max.)	V_{POmax}	Data 0A = F8	2.15	2.6	3.3	V[p-p]
Video detection output (min.)	V_{POmin}	Data 0A = 08	1.1	1.6	2.0	V[p-p]
Video detection output f characteristics	f_{PC}	Frequency to become -3 dB for 1 MHz	5.5	8	12	MHz
Sync. peak value voltage	V_{SP}	Sync. peak voltage in V_{PO} measurement	1.6	2.0	2.4	V
APC pull-in range (high)	f_{PPH}	High band side pull-in range (Difference from $f_p = 38.9\text{ MHz}$)	1.0	2.0	—	MHz

■ Electrical Characteristics at $T_a = 25^\circ\text{C}$ (continued)

Parameter	Symbol	Conditions	Min	Typ	Max	Unit
VIF circuit (continued) (Typical input $f_p = 38.9$ MHz, $V_{IN} = 90$ dB μ , DAC Data are typical)						
APC pull-in range (low)	f_{PPL}	Low band side pull-in range (Difference from $f_p = 38.9$ MHz)	—	-2.0	-1.0	MHz
RF AGC delay point adjusting range	ΔV_{RFDP}	Input to become delay point ($V_{27} =$ approx. 6.5 V) at Data 0C = 00 to 7F	75	—	95	dB μ
VCO free-running frequency	Δf_p	Dispersion without input V_{IN} , V_{36} (IF AGC) = 0 V (Measurement of difference from 38.9 MHz)	-1.2	0	1.2	MHz
RF AGC maximum sink current	I_{RFmax}	Maximum current IC can sink when pin 27 is low	1.5	3.0	—	mA
RF AGC minimum sink current	I_{RFmin}	IC leakage current at which pin 27 is high	-50	0	50	μA
AFT discrimination sensitivity	μ_{AFT}	$Df = \pm 25$ kHz	40	57	75	mV/kHz
AFT center voltage	V_{AFT}	V_{30} without input V_{IN}	4.0	4.5	5.0	V
AFT maximum output voltage	V_{AFTmax}	V_{30} at $f = f_p - 500$ kHz	7.8	8.1	8.7	V
AFT minimum output voltage	V_{AFTmin}	V_{30} at $f = f_p + 500$ kHz	0.3	0.8	1.0	V
Detection output resistance	R_{O39}	DC measurement	70	120	170	Ω
External mode output DC voltage	V_{39EXT}	Output DC voltage in AV SW external mode (04 - D6 = 1)	0.5	1.0	1.8	V
SIF circuit (Typical input $f_s = 6.0$ MHz, $f_M = 400$ Hz, $V_{IN} = 90$ dB μ)						
Audio detection output (PAL)	V_{SOP}	$\Delta f = \pm 50$ kHz 0D - D7 = 0, $R_{237} = 560$ k Ω	480	600	720	mV[rms]
Audio detection output (NTSC/PAL)	$R_{SN/P}$	$\Delta f = \pm 25$ kHz, $R_{237} = 560$ k Ω 0D - D7 = 1, ratio to PAL	-2.5	-0.5	1.5	dB
Audio detection output linearity	ΔV_{SOP}	Ratio of at $f_s = 6.0$ MHz to 6.5 MHz, and to 5.5 MHz (270 k Ω addition between pin 37 and V_{CC1})	-2.5	0	2.5	dB
SIF pull-in range (PAL)	f_{SPP}	PAL mode (0D - D7 = 0) pull-in range $R_{237} = 560$ k Ω	5.7	—	6.8	MHz
SIF pull-in range (NTSC)	f_{SPN}	NTSC mode (0D - D7 = 1) pull-in range range $R_{237} = 560$ k Ω	4.2	—	4.8	MHz
SIF pull-in range (5.5 MHz)	$f_{SP5.5}$	PAL mode (0D - D7 = 0) 270 k Ω addition between pin 37 and V_{CC1}	5.2	—	5.8	MHz
SIF input resistance	R_{I34}	DC measurement	8	10	12	k Ω
De-emphasis pin output resistance (PAL)	R_{29P}	Impedance of pin 29 at PAL	32	40	48	k Ω
De-emphasis pin output resistance (NTSC)	R_{29N}	Impedance of pin 29 at NTSC	48	60	72	k Ω
AV SW circuit						
Video SW voltage gain	G_{VSW}	$f = 1$ MHz, $V_{IN} = 1$ V[p-p]	6.2	7.2	8.2	dB
Video SW f characteristics	f_{VSW}	Frequency to become -3 dB from $f = 1$ MHz	10	—	—	MHz

■ Electrical Characteristics at $T_a = 25^\circ\text{C}$ (continued)

Parameter	Symbol	Conditions	Min	Typ	Max	Unit
AV SW circuit (continued)						
Video SW external input pin voltage	V_{31}	DC measurement	1.7	2.0	2.3	V
Video SW external output DC voltage	V_{36E}	DC measurement Data 04 – D6 = 1	4.2	4.8	5.4	V
Video SW external input resistance	R_{I31}	DC measurement	44	56	68	k Ω
Video SW output resistance	R_{O36}	DC measurement	100	140	180	Ω
Audio SW voltage gain	G_{ASW}	Data 04 – D6 = 1 (Outside) $f = 400 \text{ Hz}$, $V_{IN} = 1 \text{ V[p-p]}$	-1	0	1	dB
Audio SW input pin voltage	V_{33}	DC measurement	3.7	4.2	4.7	V
Audio SW input output DC voltage	V_{28}	DC measurement	3.7	4.2	4.7	V
Audio SW input resistance	R_{I31}	DC measurement	61	72	83	k Ω
Audio SW output resistance	R_{O28}	DC measurement	200	400	600	Ω
Video SW internal clamp pin voltage	V_{38}	DC measurement	1.3	1.6	1.9	V
Video SW internal output DC voltage	V_{36I}	DC measurement, Data 04 – D6 = 0	3.1	3.7	4.3	V
Video signal processing circuit (In the following test conditions, the measurements are made with input 0.6 V[p-p] ($V_{WB} = 0.42 \text{ V[0-p]}$) stair-step, G-out.)						
Video output (typ.)	V_{YO}	Data 03 = 40 (typ.) (Contrast)	1.65	2.1	2.55	V[p-p]
Video output (max.)	V_{YOmax}	Data 03 = 7F (max.)	3.6	4.5	5.35	V[p-p]
Video output (min.)	V_{YOmin}	Data 03 = 00 (min.)	0.07	0.25	0.5	V[p-p]
Contrast variable range	$Y_{Cmax/min}$	$\frac{03 = 7F}{03 = 00}$	20	25	33	dB
Video frequency characteristics	fY_C	Data 0E – D1 = 1 (Trap Off) Data 04 = 00 (Sharpness) Frequency to become -3 dB from $f = 0.2 \text{ MHz}$	5.5	6.8	—	MHz
Picture quality variable range	$Y_{Smax/min}$	$\frac{04 = 3F}{04 = 00}$ $f = 3.8\text{MHz}$ Data 0E – D1 = 1	9	13	17	dB
Pedestal level (typ.)	V_{PED}	Data 02 = 80 (typ.) (Brightness)	1.9	2.5	3.1	V
Pedestal level variable width	ΔV_{PED}	Difference between Data 02 = 00 and FF	2.0	2.6	3.2	V
Brightness control sensitivity	ΔV_{BRT}	Average amount of change for 1 Step between Data 02 = 60 and A0	7	11	14	mV/Step
Video input clamp voltage	V_{YCLP}	Clamp voltage of pin 43	3.2	3.7	4.2	V
ACL sensitivity	ACL	Change of Y-out when $V_{20} = 3.0 \text{ V} \rightarrow 3.5 \text{ V}$	2.1	2.7	3.2	V/V
Blanking Off threshold voltage	V_{BOFF}	Maximum blanking Off voltage in lowering pin 42 voltage	0.3	0.5	0.9	V
Blanking level	V_{YBL}	DC voltage of blanking pulse	0.5	1.0	1.5	V
DC restoration ratio	T_{DC}	APL 10% to 90% $T_{DC} = \frac{\Delta AC - \Delta DC}{\Delta AC} \times 100$	90	100	110	%

■ Electrical Characteristics at $T_a = 25^\circ\text{C}$ (continued)

Parameter	Symbol	Conditions	Min	Typ	Max	Unit
Video signal processing circuit (continued) (In the following test conditions, the measurements are made with input: 0.6 V[p-p] ($V_{WB} = 0.42$ V[0-p] stair-step) at G-out.)						
Video input clamp current	I_{YCLP}	DC measurement: IC inside sink current	8	13	18	μA
ACL start point	V_{ACL}	V_{20} at which output amplitude becomes 90% in decreasing ACL pin (V_{20}) from 5 V	3.4	3.7	4.0	V
Color signal processing circuit (In the following test conditions, burst 300 mV[p-p] (PAL) and reference is B-out)						
Color-difference output (typ.)	V_{CO}	Input: Color bar Data 00 = 40 (typ.), 03 = 40 (typ.)	2.6	3.3	4.0	V[p-p]
Color-difference output (max.)	V_{COmax}	Data 00 = 7F amplitude of one side Data 03 = 40	2.3	3.0	—	V[0-p]
Color-difference output (min.)	V_{COmin}	Data 00 = 00 Data 03 = 40	0	—	100	mV[p-p]
Contrast variable range	$C_{Cmax/min}$	03 = FF Data 00 = 40 03 = 00	20	25	33	dB
ACC characteristics 1	ACC1	Burst 300 mV[p-p]→600 mV[p-p] Input; Rainbow	0.9	1.0	1.2	Time
ACC characteristics 2	ACC2	Burst 300 mV[p-p]→60 mV[p-p] Input; Rainbow	0.7	1.0	1.1	Time
NTSC tint center	$\Delta\theta_C$	Difference from Data = 01 = 40 (Tint) at which tint is adjusted to center.	-13	0	+13	Step
NTSC tint variable range 1	$\Delta\theta_1$	Data 01 = 7F	30	50	65	deg
NTSC tint variable range 2	$\Delta\theta_2$	Data 01 = 00	-65	-50	-30	deg
Color-difference output ratio (R)	R/B	Input; Rainbow for both PAL/NTSC	0.71	0.83	0.95	Time
Color-difference output ratio (G)	G/B	Input; Rainbow for both PAL/NTSC	0.31	0.37	0.43	Time
Color-difference output angle (R)	$\angle R$	Input; Rainbow for both PAL/NTSC	78	90	102	deg
Color-difference output angle (G)	$\angle G$	Input; Rainbow for both PAL/NTSC	224	236	248	deg
PAL color killer tolerance	V_{KilIP}	0 dB = 300 mV[p-p]	-57	-44	-34	dB
NTSC color killer tolerance	V_{KilIN}	0 dB = 300 mV[p-p]	-57	-44	-34	dB
APC pull-in range (high)	f_{CPH}	For both PAL/NTSC	450	900	—	Hz
APC pull-in range (low)	f_{CPL}	For both PAL/NTSC	—	-900	-450	Hz
Color killer detection output voltage (Color)	V_{KC}	V_5 measured when chroma is input	4.5	5.0	—	V
Color killer detection output voltage (B&W)	V_{KBW}	V_5 measured when no chroma is input	0	0.1	0.5	V
Demodulation output-(B-Y)	V_{DB}	Input; Color bar, measurement by pin 60	555	695	835	mV[p-p]
Demodulation output-(R-Y)	V_{DR}	Input; Color bar, measurement by pin 61	430	540	650	mV[p-p]
Demodulation output angle $\angle B$	\angle_{RDB}	Phase shift of B-Y axis	-5	0	5	deg

■ Electrical Characteristics at $T_a = 25^\circ\text{C}$ (continued)

Parameter	Symbol	Conditions	Min	Typ	Max	Unit
Color signal processing circuit (continued) (In the following test conditions, burst 300 mV[p-p] (PAL) and reference is B-out)						
Demodulation output angle $\angle R$	\angle_{RDR}	Phase difference from B-Y axis	85	90	95	deg
CW output level (4.43 MHz)	V_{CWP}	AC component when V_{CO} is set at 4.43 MHz	250	300	350	mV[p-p]
CW output level (3.58 MHz)	V_{CWN}	AC component when V_{CO} is set at 3.58 MHz	—	0	50	mV[p-p]
CW output level period (SECAM)	T_{CW}	CW output period at SECAM	1.31	1.41	1.51	ms
SECAM discrimination current	I_{SECAM}	Minimum value for taking out current from pin 59 and discriminating as SECAM	50	100	150	μA
PAL/NTSC DC level	V_{59PN}	V_{59} DC level at PAL/SECAM	0.8	1.3	1.65	V
SECAM DC level	V_{59S}	V_{59} DC level at SECAM	4.1	4.6	5.1	V
PAL/NTSC output impedance	$R_{60,61PN}$	DC measurement. pin 60, 61 impedance at PAL/NTSC	390	480	570	Ω
SECAM output impedance	$R_{60,61S}$	DC measurement. pin 60, 61 impedance at SECAM	100	—	—	k Ω
RGB Processing Circuit (DAC Data are typical)						
Pedestal difference voltage	ΔV_{IPL}	Difference voltage of R,G,B out pedestal	0	—	0.3	V
Brightness voltage tracking	ΔT_{BL}	R, G, B out fluctuation level ratio of DATA 02 (Brightness) 02 = 40 to C0	0.9	1.0	1.1	Time
Video voltage gain relative ratio	ΔG_{YC}	Output ratio of R,B out to G out	0.8	1.0	1.2	Time
Video voltage gain tracking	ΔT_{CONT}	Gain ratio of R, G, B out of Data 03 (Contrast) 03 = 20 to 60	0.9	1.0	1.1	Time/ Time
Drive adjustment range	G_{DV}	AC change amount of R, B out between drive adjustment max. and min.	5.3	6.3	7.3	dB
Cut-off adjustment range	$V_{CUT-OFF}$	DC change amount of R, G, B out between cutoff adjustment at max. and min.	1.9	2.2	2.5	V
Y_S threshold voltage	V_{YS}	Minimum DC voltage, when Y_S turns on	0.7	1.0	1.3	V
External RGB pedestal voltage	V_{EPL}	Y_S is On	1.7	2.3	2.9	V
External RGB pedestal difference voltage	ΔV_{EPL}	Y_S is On	0	—	250	mV
Internal and external pedestal difference voltage	$\Delta V_{PL/IE}$	Internal-external	50	200	400	mV
External RGB output voltage	V_{ERGB}	Input 3 V[p-p], contrast 03 = 7F	4.3	5.4	6.5	V[p-p]
External RGB output difference voltage	ΔV_{ERGB}	Input 3 V[p-p], contrast 03 = 7F	-0.6	0	0.6	V
External RGB contrast variable range	$E_{Cmax/min}$	$\frac{03 = 7F}{03 = 00}$	10	13	16	dB
External RGB frequency characteristics	f_{RGC}	Input 0.2 V[p-p], DC = 1 V	8	12	—	MHz

■ Electrical Characteristics at $T_a = 25^\circ\text{C}$ (continued)

Parameter	Symbol	Conditions	Min	Typ	Max	Unit
Synchronizing signal processing circuit						
Horizontal free-running oscillation frequency	f_{HO}	Without sync. signal input	15.33	15.63	15.93	kHz
Horizontal output pulse duty cycle	τ_{HO}	Upward going pulse duty cycle	31	37	43	%
Horizontal pull-in range	f_{HP}	Difference from $f_{\text{H}} = 15.625$ kHz	± 500	± 650	—	Hz
PAL vertical free-running oscillation frequency	$f_{\text{VO-P}}$	Data 0E – D2 = 1, D3 = 0 Forced 50 Hz mode, no sync. signal input	48	50	52	Hz
NTSC vertical free-running oscillation frequency	$f_{\text{VO-N}}$	Data 0E – D2 = 1, D3 = 1 Forced 60 Hz mode, no sync. signal input	58	60	62	Hz
Vertical output pulse width	τ_{VO}	For both PAL/NTSC	9	10	11	$1/f_{\text{H}}$
PAL vertical pull-in range	$f_{\text{VP-P}}$	$f_{\text{H}} = 15.625$ kHz, forced 50 Hz mode	46	—	54	Hz
NTSC vertical pull-in range	$f_{\text{VP-N}}$	$f_{\text{H}} = 15.75$ kHz, forced 60 Hz mode	56	—	64	Hz
Horizontal output voltage (high)	$V_{56\text{H}}$	High level DC voltage	3.2	3.5	3.8	V
Horizontal output voltage (low)	$V_{56\text{L}}$	Low level DC voltage	0	—	0.3	V
Vertical output voltage (high)	$V_{58\text{H}}$	High level DC voltage	3.9	4.2	4.5	V
Vertical output voltage (low)	$V_{58\text{L}}$	Low level DC voltage	0	—	0.3	V
Picture center variable range	ΔT_{HC}	Change amount of phase difference between H Sync. and H-out of Data 0A = 80 to 8F	2.6	3.2	4.4	μS
Overshoot protective operation voltage	V_{XRAY}	Pin 55 minimum voltage at which H-out stops to appear	0.60	0.68	0.76	V
Vertical frequency discrimination (50)	f_{50}	Vertical frequency to become V_{57} = Low (< 0.5 V)	47	—	55	Hz
Vertical frequency discrimination (60)	f_{60}	Vertical frequency to become V_{57} = High (> 4.5 V)	57	—	63	Hz
Sync. signal clamp voltage (Ver.)	V_{45}	Clamp voltage of V_{45}	1.0	1.3	1.6	V
Sync. signal clamp voltage (Hor.)	V_{46}	Clamp voltage of V_{46}	1.0	1.3	1.6	V
Horizontal output start voltage	V_{HHS}	Minimum V_{50} to become $f_0 > 10$ kHz, when horizontal oscillation output is 1 V[p-p] or more.	3.4	4.2	5.0	V
I ² C interface						
Sink current when ACK	I_{ACK}	Maximum value of pin 21 sink current at ACK	2.0	2.5	5.0	mA
SCL, SDA signal input high level	V_{IHI}		3.1	—	5.0	V
SCL, SDA signal input low level	V_{ILO}		0	—	0.9	V
Maximum frequency allowable to input	f_{Imax}		100	—	—	Kbit/s

■ Electrical Characteristics at $T_a = 25^\circ\text{C}$ (continued)

• Design reference data

Note) The characteristic listed below are theoretical values based on the IC design and are not guaranteed.

Parameter	Symbol	Conditions	Min	Typ	Max	Unit
VIF circuit (Typical input $f_p = 38.9$ MHz, $V_{IN} = 90$ dB μ)						
Input sensitivity	V_{PS}	Input level to become $V_{PO} = -3$ dB	—	45	51	dB μ
Maximum allowable input	V_{Pmax}	Input level to become $V_{PO} = 1$ dB	104	110	—	dB μ
SN ratio	SN_P		50	53	—	dB
Differential gain	DG_P		0	3	5	%
Differential phase	DP_P		0	3	5	deg
Black noise detection level	ΔV_{BN}	Deference from sync. peak value	-55	-45	-35	IRE
Black noise clamp level	ΔV_{BNC}	Deference from sync. peak value	35	45	35	IRE
RF AGC operation sensitivity	G_{RF}	Input level difference to become $V_{27} = 1$ V \rightarrow 7 V	0.5	1.5	3.0	dB
VCO switch On drift	Δf_{PD}	Frequency drift from 5 seconds to 5 mins. after SW On	100	150	200	kHz
Intermodulation	IM	$V_{IC} - V_{IP} = -2$ dB, $V_{IS} - V_{IP} = -12$ dB	46	52	—	dB
RF AGC adjustment sensitivity	S_{RF}	Average amount of change of output voltage V_{27} at Data 1Step	1.0	1.7	2.5	V/Step
AFT offset adjustment sensitivity	S_{AFT}	Average amount of change of output voltage V_{30} per Data 1Step	0.15	0.2	0.25	V/Step
Video detection output fluctuation with V_{CC}	$\Delta V_{P/V}$	$V_{CC} = \pm 10\%$	—	± 10	± 15	%
Video detection output-temperature characteristics	$\Delta V_{P/T}$	$T_a = -10^\circ\text{C}$ to $+70^\circ\text{C}$	—	± 5	± 10	%
Input resistance (pin 24, 25)	$R_{I24, 25}$	$f = 38.9$ MHz	—	1.2	—	k Ω
Input capacitance (pin 24, 25)	$C_{I24, 25}$	$f = 38.9$ MHz	—	4.0	—	pF
Sound IF output level	V_{SIF}	$f_S = 38.9$ MHz $- 6.0$ MHz, P/S = 20 dB	94	100	106	dB μ
VCO control sensitivity	β_P	$\Delta V_{41} = \pm 0.1$ V	2.0	2.7	3.5	kHz/mV
VCO control range	f_{VCO}	Free-running frequency change width from Data 0D = 00 to 7F	3.0	4.0	5.0	MHz
RF AGC delay-point temperature characteristics	$\Delta V_{DP/T}$	$T_a = -20^\circ\text{C}$ to $+70^\circ\text{C}$	0	3	5	dB
VCO free-running frequency temperature characteristics	$\Delta f_{P/T}$	$T_a = -20^\circ\text{C}$ to $+70^\circ\text{C}$	—	300	—	kHz
AFT center frequency temperature characteristics	$\Delta f_{AFT/T}$	$T_a = -20^\circ\text{C}$ to $+70^\circ\text{C}$, input frequency at which AFT output voltage becomes 4.5 V	—	300	—	kHz

■ Electrical Characteristics at $T_a = 25^\circ\text{C}$ (continued)

• Design reference data (continued)

Note) The characteristic listed below are theoretical values based on the IC design and are not guaranteed.

Parameter	Symbol	Conditions	Min	Typ	Max	Unit
SIF circuit (Typical input $f_S = 6.0\text{ MHz}$, $f_M = 400\text{ Hz}$, $V_{IN} = 90\text{ dB}\mu$)						
Input limiting level	V_{LIM}	Input level to become $V_{SOP} = -3\text{ dB}$	—	44	50	$\text{dB}\mu$
AM rejection ratio	AMR	AM = 30%	60	70	—	dB
Total harmonic distortion	THD	$\Delta f = \pm 50\text{ kHz}$	0	0.3	0.5	%
SN ratio	SN_A		50	55	—	dB
Audio output with V_{CC} fluctuation	$\Delta V_{S/V}$	$V_{CC} = \pm 10\%$	—	± 3	± 6	%
Audio output-temperature characteristics	$\Delta V_{S/T}$	$T_a = -20^\circ\text{C}$ to $+70^\circ\text{C}$	—	± 5	± 10	%
AV SW circuit						
Video SW cross-talk	CT_{VSW}	$f = 1\text{ MHz}$, $V_{IN} = 1\text{ V[p-p]}$ Internal→External, External→Internal	—	-66	-60	dB
Audio SW cross-talk (Internal→External)	CT_{AIE}	$f_S = 6.0\text{ MHz}$, $f_M = 400\text{ Hz}$ Without input from outside	—	-73	-67	dB
Audio SW cross-talk (External→Internal)	CT_{AEI}	$f_S = 6.0\text{ MHz}$, $f_M = 0\text{ Hz}$ $f_M = 400\text{ Hz}$, $V_{IN} = 600\text{ mV[rms]}$	—	-73	-67	dB
Video signal processing circuit (In the following test conditions, the measurements are made at G-out with input 0.6 V[p-p] ($V_{WB} = 0.42\text{ V[0-p]}$.))						
Y signal delay time	T_{DL}	Phase difference from Y input (PAL: 4.43 MHz)	620	690	790	ns
Black level extension1	V_{BL1}	Input: Total black, difference between pin 42 of 9 V and Open (With RC filter)	-100	0	100	mV
Black level extension2	V_{BL2}	Input: Total black, difference between pin 42 of 3 V and 9 V	500	800	1100	mV
Black level extension3	V_{BL3}	Input: approx. 20IRE, voltage difference between pin 42 of Open and 9 V	100	300	500	mV
Contrast variation with sharpness	ΔV_{CS}	Y-out output level difference between sharpness max. and min.	-300	0	300	mV
Brightness variation with sharpness	ΔV_{BS}	Pedestal level DC difference between sharpness is at max. and min.	-250	0	250	mV
Input dynamic range	VI_{max}	Contrast 03 = 40	1.0	1.7	—	V[p-p]
Y signal SN ratio	SN_Y	Contrast 03 = 7F	51	56	—	dB
Black level extension start point	V_{BLS}	Start point at $V_{48} = 4.5\text{ V}$	37	42	47	IRE
Trap on/off gain difference	ΔG_{TRAP}	Trap on/off	-1	0	1	dB
Trap on/off delay time change amount	ΔT_{TRAP}	Trap on/off	350	390	430	ns

■ Electrical Characteristics at $T_a = 25^\circ\text{C}$ (continued)

• Design reference data (continued)

Note) The characteristic listed below are theoretical values based on the IC design and are not guaranteed.

Parameter	Symbol	Conditions	Min	Typ	Max	Unit
Video signal processing circuit (continued) (In the following test conditions, the measurements are made at G-out with input 0.6 V[p-p] ($V_{WB} = 0.42\text{ V}[0\text{-p}]$).						
Trap frequency error	Δf_{TRAP}	Trap center frequency, when chroma input is 4.43 MHz	-70	0	70	kHz
Trap attenuation amount	$A_{\text{TT TRAP}}$	Attenuation amount of 4.43 MHz, when chroma input is 4.43 MHz	26	30	—	dB
Trap automatic adjustment range	f_{TRAP}	VCO frequency of $\Delta f_{\text{TRAP}} \leq 70\text{ kHz}$	3	—	5	MHz
Trap fixed frequency	f_{ST}	Data 0E – D6 = 1, Trap frequency	4.0	4.8	5.6	MHz
Video output fluctuation with V_{CC}	$\Delta V_{\text{Y/V}}$	$V_{\text{CC1}} = 9\text{ V}$ (allowance: $\pm 10\%$)	0	100	200	mV/V
Video output-temperature characteristics	$\Delta V_{\text{Y/T}}$	$T_a = -20^\circ\text{C}$ to $+70^\circ\text{C}$	0	5	10	%
PAL/NTSC delay time difference	$\Delta T_{\text{P/N}}$	Trap On (NTSC-PAL)	-10	10	30	ns
Color signal processing circuit (Burst 300 mV[p-p] (PAL), reference is B-out)						
Demodulation output residual carrier	V_{CAR1}	$2f_{\text{SC}}$ level of pin 60 and 61	0	—	30	mV
Color difference output residual carrier	V_{CAR2}	$2f_{\text{SC}}$ level of pin 15, 16, and 17	0	—	50	mV
VCO free-running frequency (PAL)	f_{CP}	Difference from $f = 4.433619\text{ MHz}$	-300	0	300	Hz
VCO free-running frequency (NTSC)	f_{CN}	Difference from $f = 3.579545\text{ MHz}$	-300	0	300	Hz
f_{CO} fluctuation with V_{CC}	$\Delta V_{\text{C/V}}$	$V_{\text{CC1}} = 9\text{ V}$ (allowance: $\pm 10\%$), $V_{\text{CC3}} = 5\text{ V}$ (allowance: $\pm 10\%$)	-300	0	300	Hz
Static phase error (PAL)	$\Delta\theta_{\text{P}}$	Tint shift from $\Delta f_{\text{C}} = -300\text{ Hz}$ to $+300\text{ Hz}$ change	0	2	5	deg/ 100 Hz
Static phase error (NTSC)	$\Delta\theta_{\text{N}}$	Tint shift from $\Delta f_{\text{C}} = -300\text{ Hz}$ to $+300\text{ Hz}$ change	0	2	5	deg/ 100 Hz
PAL/NTSC	$R_{\text{P/N}}$	Output amplitude ratio of PAL to NTSC	0.8	1.0	1.2	Time
Line crawling	ΔV_{PAL}	Pin 61: Output amplitude difference per 1H for -(R-Y) pin	0	—	50	mV
Color difference output bandwidth	f_{CC}	Band to become -3 dB	—	1.0	—	MHz
Chroma BPF characteristics (PAL)	BPF_{P}	Output level difference between $f = 4.43\text{ MHz}$ and 3.58 MHz	—	10	—	dB
Chroma BPF characteristics (NTSC)	BPF_{N}	Output level difference between $f = 3.58\text{ MHz}$ and 2.0 MHz (when Ext. video)	—	13	—	dB
Color-difference output fluctuation with V_{CC}	$\Delta V_{\text{C/V}}$	$V_{\text{CC1}} = 9\text{ V}$ (allowance: $\pm 10\%$) $V_{\text{CC3}} = 5\text{ V}$ (allowance: $\pm 10\%$)	—	± 10	± 15	%
Color-difference output -temperature characteristics	$\Delta V_{\text{C/T}}$	$T_a = -20^\circ\text{C}$ to $+70^\circ\text{C}$	—	± 10	± 15	%

■ Electrical Characteristics at $T_a = 25^\circ\text{C}$ (continued)

• Design reference data (continued)

Note) The characteristic listed below are theoretical values based on the IC design and are not guaranteed.

Parameter	Symbol	Conditions	Min	Typ	Max	Unit
Color signal processing circuit (continued) (Burst 300 mV[p-p] (PAL), reference is B-out)						
Brightness variation with color	V_{BC}	Pedestal level DC difference between at contrast max. and min.	-250	0	250	mV
Brightness variation difference voltage with color	ΔV_{BC}	R, G, B out variation voltage difference	0	—	20	mV
RGB processing circuit						
(C-Y)/Y	$R_{C/Y}$	Color bar input, B-out Contrast typ., color Data 00 = 60	0.9	1.2	1.5	V[0-p]/ V[p-p]
(C-Y), Y delay difference	$\Delta T_{C/Y}$	Color bar input, B-out Phase of green→magenta	-100	0	100	ns
Y_S changeover speed	f_{YS}	f_{YS} , when external input is 3 V, output level -3 dB	7	11	—	MHz
External RGB input dynamic range	V_{DEXT}	Contrast max., Data 03 = 77F	2.0	2.5	3.2	V[0-p]
Internal/external crosstalk	CT_{RGB}	Leakage when $f = 1$ MHz, 1 V[p-p], and $Y_S = 5$ V	—	-60	-50	dB
Spot killer operation	V_{SPK}	V_9 , when V_9 is decreased from 9 V and spot killer turns on.	7.4	7.8	8.2	V
Brightness variation with contrast	V_{BAC}	Pedestal level DC difference between contrast max. and min.	-250	0	250	mV
Brightness variation difference voltage with contrast	ΔV_{BAC}	R, G, B out variation voltage difference	0	—	20	mV
Pedestal level fluctuation with V_{CC}	$\Delta V_{PL/V}$	$V_{CC1} = 9$ V (allowance: $\pm 10\%$)	0	200	400	mV/V
Pedestal level- temperature characteristics	$\Delta V_{PL/T}$	$T_a = -20^\circ\text{C}$ to $+70^\circ\text{C}$	-2.6	-2.2	-1.8	mV/ $^\circ\text{C}$
Pedestal level 2	V_{PD2}	Pedestal level, when G cutoff Data 05 = 18	2.1	2.7	3.3	V
Synchronizing signal processing circuit						
Lock detection output voltage	V_{LD}	V_{18} at horizontal AFC lock	5.7	6.3	6.9	V
Lock detection charge and discharge current	I_{LD}	DC measurement	± 0.6	± 0.8	± 1.1	mA
EBP (RGB) slice level	V_{FBP}	Minimum voltage of pin 50, when blanking is applied to RGB output	0.4	0.75	1.1	V
EBP (AFC2) slice level	V_{FBPH}	Minimum voltage of pin 50 at which AFC2 operates	1.5	1.9	2.3	V
Horizontal AFC μ	μ_H	DC measurement	30	37	44	$\mu\text{A}/\mu\text{s}$
Horizontal VCO β	β_H	β curve gradient near $f = 15.7\text{kHz}$	1.4	1.9	2.4	Hz/mV
Burst gate pulse position	P_{BGP}	For both PAL/NTSC, delay from H. Sync. rise	0.2	0.4	0.6	μs

■ Electrical Characteristics at $T_a = 25^\circ\text{C}$ (continued)

• Design reference data (continued)

Note) The characteristic listed below are theoretical values based on the IC design and are not guaranteed.

Parameter	Symbol	Conditions	Min	Typ	Max	Unit
Synchronizing signal processing circuit (continued)						
PAL burst gate pulse width	W_{BGPP}		3.4	4.0	4.6	μs
NTSC burst gate pulse width	W_{BGPN}		2.5	3.0	3.5	μs
Burst gate pulse output voltage	V_{BGP}	DC voltage of pin 62 in BGP period	4.5	4.7	4.9	V
H blanking pulse output voltage	V_{HBLK}	DC voltage in H-blanking pulse period of pin 62	2.1	2.4	2.7	V
V blanking pulse output voltage	V_{VBLK}	DC voltage in V-blanking pulse period of pin 62	2.1	2.4	2.7	V
PAL V blanking pulse width	W_{VP}	Pulse width at $f_H = 15.625\text{ kHz}$	1.31	1.41	1.51	ms
NTSC blanking pulse width	W_{VN}	Pulse width at $f_H = 15.73\text{ kHz}$	1.01	1.11	1.21	ms
FBP allowable range	T_{FBP}	Time from H-out rise to FBP center	12	—	19	μs
I ² C interface						
Bus free before start	t_{BUF}		4.0	—	—	μs
Start condition set-up time	$t_{SU.STA}$		4.0	—	—	μs
Start condition hold time	$t_{HD.STA}$		4.0	—	—	μs
Low period SCL, SDA	t_{LOW}		4.0	—	—	μs
High period SCL	t_{HIGH}		4.0	—	—	μs
Rise time SCL, SDA	t_r		—	—	1.0	μs
Fall time SCL, SDA	t_f		—	—	0.35	μs
Data set-up time (write)	$t_{SU.DAT}$		0.25	—	—	μs
Data hold time (write)	$t_{HD.DAT}$		0	—	—	μs
Acknowledge set-up time	$t_{SU.ACK}$		—	—	3.5	μs
Acknowledge hold time	$t_{HD.ACK}$		0	—	—	μs
Stop condition set-up time	$t_{SU.STO}$		4.0	—	—	μs
DAC						
4, 6, 7bit DAC DNLE	$L_{4,6,7}$	$1\text{LSB} = \{\text{Data (max.)} - \text{Data (00)}\} / 15, 63, 127$	0.1	1.0	1.9	$\frac{\text{LSB}}{\text{Step}}$
8bit DAC DNLE	L_8	$1\text{LSB} = \{\text{Data (FF)} - \text{Data (00)}\} / 255$	0.1	1.0	1.9	$\frac{\text{LSB}}{\text{Step}}$
Cut off DAC overlap	ΔStep	Overlap of 8-bit 2-stage changeover (Same for AFT) of R, B cut-off	27	32	37	Step

■ Electrical Characteristics at $T_a = 25^\circ\text{C}$ (continued)

• Typical conditions when testing

1. Input signal

- 1) VIF : $f_p = 38.9\text{ MHz}$, $V_{IN} = 90\text{ dB}\mu$
Video modulation: modulated signal is 10-staircase. Modulation $m = 87.5\%$
 $V_{IN} = 90\text{ dB}\mu$, pin 25 input level approx. $84\text{ dB}\mu$
- 2) SIF : $f_s = 6.0\text{ MHz}$, $V_{IN} = 90\text{ dB}\mu$, modulated signal $f_M = 400\text{ Hz}$, Deviation: PAL $\pm 50\text{ kHz}$,
NTSC $\pm 25\text{ kHz}$
- 3) Video : 10-staircase 0.6 V[p-p] ($V_{BW} = 0.42\text{ V[0-p]}$)
- 4) Chroma : Color bar signal: Burst level 300 mV[p-p]
: Rainbow signal : Burst level 300 mV[p-p]
- 5) Sync. signal : Video signal 1.5V[p-p] to 2.5 V[p-p] for both horizontal and vertical sync. signal input

2. I²C BUS conditions: (PAL)

Sub Address	Data(H)
00	40
01	40
02	80
03	40
04	80
05	00
06	00
07	00
08	80
09	80
0A	88
0B	01
0C	40
0D	40
0E	01

Control	Data(H)
Color	00 = 40
Tint	01 = 40
Brightness	02 = 80
Contrast	03 = 40
Sharpness	04 = 00
Cut-off R, B	05, 07 = 00
Cut-off G	06 = 00
Drive R, B	08, 09 = 80
Video output	0A (Upper rank) = 8*
Picture center position	0A (Lower rank) = *8
AFT	0B = 01 04 – D7 = 1
RF AGC	0C = 40
VIF VCO	0D = 40

■ Terminal Equivalent Circuits

Pin No.	Equivalent circuit	Description	I/O
1 2 3		<p>Pin 1: Color difference signal clamp pin (R-Y)</p> <p>Pin 2: Color difference signal clamp pin (G-Y)</p> <p>Pin 3: Color difference signal clamp pin (B-Y)</p> <ul style="list-style-type: none"> Color difference signal inputted from pin 63, 64 is clamped according to brightness control voltage. Clamp pulse uses internal clamp pulse (BGP) 	DC approx. 7 V
4		<p>Killer filter pin</p> <ul style="list-style-type: none"> Filter pin for killer detection circuit (operates for BGP period) Killer turned On (Without color output) 2.8 V or less 	DC approx. 3.3 V
5		<p>Killer output pin</p> <ul style="list-style-type: none"> Output pin of killer detection circuit Connect 33 kΩ load resistor of pin 5 to microcomputer V_{CC} 	DC Killer On 0.2 V Killer Off 5 V
6		<p>Pin for APC filter</p> <ul style="list-style-type: none"> Filter pin for APC detection circuit (operates for BGP period) Detection sensitivity becomes large when external R → large (Tends to pull-in easily. Tends to be affected by noise) <p>β curve</p> <ul style="list-style-type: none"> When SECAM, APC circuit is stopped by short circuiting 40 kΩ resistor 	DC approx. 2.5 V

■ Terminal Equivalent Circuits (continued)

Pin No.	Equivalent circuit	Description	I/O
7 8		<p>Pin 7: Chroma oscillation pin (4.43 MHz) Pin 8: Chroma oscillation pin (3.58 MHz)</p> <ul style="list-style-type: none"> Oscillation pin for chroma. Either one of 4.43 MHz or 3.58 MHz is oscillated Oscillation frequency changeover is performed by 0E – D0 bit of I₂C Bus When 0E – D0 = 1 I_{P1} and I_{P2} turn On and 4.43 MHz oscillates. When 0E – D0 = 0 I_{N1} and I_{N2} turn on and 3.58 MHz oscillates. Pattern from pin to oscillator element should be as short as possible. 	<p>AC f = f_C approx. 0.3 V[p-p]</p>
9		<p>Spot killer pin</p> <ul style="list-style-type: none"> To be used for discharging electric charge on CRT quickly when power of set is turned Off. DC voltage of R,G,B output pin is raised when V_{CC1} drops. 	<p>DC approx. 9 V</p>
10		<p>Y_S input pin</p> <ul style="list-style-type: none"> Fast blanking pulse input pin for OSD Turns on at a voltage higher than 1 V[0-p] 	<p>AC (pulse)</p>
11 12 13		<p>Pin 11: External R input pin Pin 12: External G input pin Pin 13: External B input pin</p> <ul style="list-style-type: none"> External input pin for OSD Output changes linearly according to input level. 	<p>AC (pulse)</p>

■ Terminal Equivalent Circuits (continued)

Pin No.	Equivalent circuit	Description	I/O
14		V_{CC1} (typ. 9 V) • Output part of VIF and SIF circuit • AV SW circuit • Video circuit • RGB circuit	DC 9 V
15 16 17		Pin15: R-out pin Pin16: G-out pin Pin17: B-out pin • BLK level approx. 0.9 V • Black (Pedestal) level approx. 2.2 V • Blanking can be released when pin 42 (Black level detection pin) is set at 0 V.	AC
18		Horizontal sync. detection pin • Phase of horizontal synchronizing signal and horizontal output pulse is detected and outputted. • Pin18 is low when out of phase. • In asynchronous state, color control becomes min. and chroma output disappears. • Pay attention to impedance when the voltage of pin 18 is utilized for microcomputer ($Z_O \geq 1 M\Omega$ is required)	DC when synchronous $V_{CC2} - V_{SAT}$ when asynchronous approx. 0.3 V
19		GND • RGB circuit • DAC I ² C circuit • VIF (VCO) circuit	

■ Terminal Equivalent Circuits (continued)

Pin No.	Equivalent circuit	Description	I/O
20		<p>ACL pin</p> <ul style="list-style-type: none"> Contrast can be reduced when DC voltage of pin 20 is decreased from the outside. 	<p>DC approx. 3 V</p>
21		<p>I²C Bus Data input pin</p>	<p>AC (pulse)</p>
22		<p>I²C Clock input pin</p>	<p>AC (pulse)</p>
23		<p>V_{CC3-1} (typ. 5 V)</p> <ul style="list-style-type: none"> For VIF, SIF circuit 	<p>DC 5 V</p>

■ Terminal Equivalent Circuits (continued)

Pin No.	Equivalent circuit	Description	I/O
24 25		Pin 24: VIF input pin 1 Pin 25: VIF input pin 2 <ul style="list-style-type: none"> • Input for VIF amp. and balanced input • Input max. 120 dBμ 	AC $f = f_p$ DC level approx. 2.7 V
26		GND <ul style="list-style-type: none"> • VIF, SIF circuit 	DC
27		RF AGC output pin <ul style="list-style-type: none"> • Collector open output 	DC
28		Audio output pin <ul style="list-style-type: none"> • There is fluctuation of DC due to internal and external changeover 	AC 0 kHz to 20 kHz DC approx. 4.2 V
29		De-emphasis pin <ul style="list-style-type: none"> • De-emphasis filter pin for sound detection signal. • External C is the same for PAL and NTSC (Internal impedance changes) • PAL: $120\text{ k}\Omega // 60\text{ k}\Omega \times 1200\text{ pF} = 48\text{ }\mu\text{s}$ • NTSC: $60\text{ k}\Omega \times 1200\text{ pF} = 72\text{ }\mu\text{s}$ 	AC 0 kHz to 20 kHz

■ Terminal Equivalent Circuits (continued)

Pin No.	Equivalent circuit	Description	I/O
30		<p>AFT output pin</p> <ul style="list-style-type: none"> Center voltage offset should be adjusted by using a bus. AFT defeat SW is turned on (0B = 00), V_{30} becomes a value determined by the value of externally attached resistor-divider. AFT μ is variable by impedance of externally attached resistor. 	DC
31		<p>External video input pin</p> <ul style="list-style-type: none"> Input pin for external video signal. DC cut input. Typical 1 V[p-p] (max. 1.5 V[p-p]) 	<p>AC 1 V[p-p] (Composite)</p> <p>DC approx. 2.1 V</p>
32		<p>Decoupling pin</p> <ul style="list-style-type: none"> S curve inside IC is wide band but DC feedback is applied so that DC voltage of output signal becomes constant. DC level (typ. 4.5 V) $f_S \rightarrow \text{High}: V_{32} \rightarrow \text{Low}$ 	DC
33		<p>External audio input pin</p> <ul style="list-style-type: none"> Input pin for external audio signal input. DC cut input. Typical input level should be adjusted to internal sound level. Input max. 7 V[p-p] 	<p>AC 0 kHz to 20 kHz</p>

■ Terminal Equivalent Circuits (continued)

Pin No.	Equivalent circuit	Description	I/O
34		<p>SIF Signal input Input max. 110 dBμ</p>	<p>AC f = f_S DC approx. 2.3 V</p>
35		<p>IF AGC filter pin</p> <ul style="list-style-type: none"> Pin for IF AGC filter. The current obtained from peak AGC circuit is smoothed by external capacitor. Since response becomes faster when C → small, but sag tends to appear easily. 	<p>DC approx. 2 V</p>
36		<p>Video output pin</p> <ul style="list-style-type: none"> Int. video or Ext. video signal selected by AV SW is outputted. DC fluctuates by internal/external changeover 	<p>AC 2 V[p-p]</p>  <p>DC level approx. 4.5 V</p>
37		<p>SIF APC filter pin</p> <ul style="list-style-type: none"> Filter pin for APC circuit of SIF Recommended resistance value for single frequency (R237: Connect between the pin and V_{CC1}) <p>6.5 MHz: Open 6.0 MHz: 560 kΩ 5.5 MHz: 200 kΩ 4.5 MHz: 560 kΩ</p>	<p>DC approx. 2.5 V</p>

■ Application Circuit Example

