

RF Amplifier for CD Players

Description

The CXA1791M/N is an IC developed for compact disc players. This IC incorporates an APC circuit and amplifiers for 3-spot optical pick-up output, focus error, and tracking error.

Features

- Low power consumption (40mW at ±2.5V).
- Supports the RF amplifier at double speed.
- APC circuit.
- Operates at dual ±5V power supply or single +5V power supply.
- The gains for APC circuit and each amplifier are interchangeable with these of the CXA1571.

Absolute Maximum Ratings

- Supply voltage $V_{CC}-V_{EE}$ 12 V
- Operating temperature T_{opr} -20 to +85 °C
- Storage temperature T_{stg} -65 to +150 °C
- Allowable power dissipation P_D (SOP) 600 mW
(SSOP) 375 mW

Operating Conditions

Supply voltage $V_{CC}-V_{EE}$ 3.0 to 11.0 V

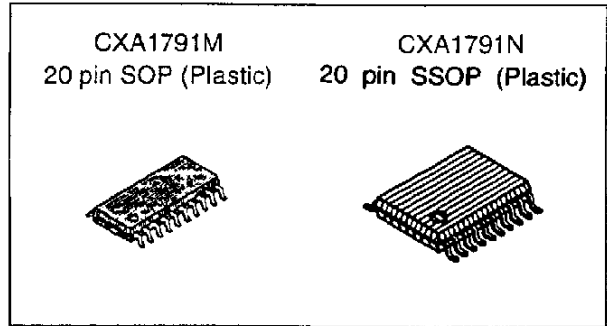

Functions

- RF amplifier
- Focus error amplifier
- Tracking error amplifier
- APC circuit

Applications

Compact disc players

Structure

Bipolar silicon monolithic IC

Block Diagram and Pin Configuration (Top View)

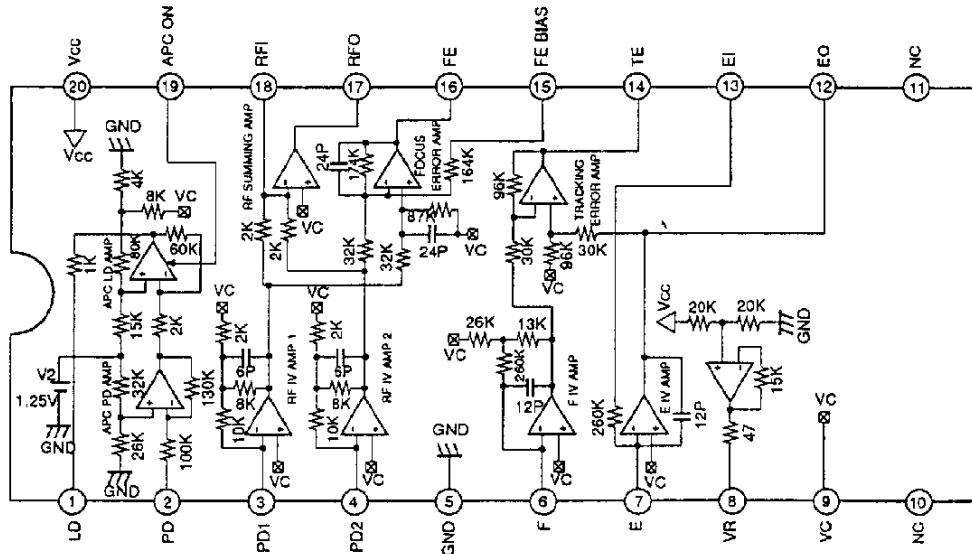

Sony reserves the right to change products and specifications without prior notice. This information does not convey any license by any implication or otherwise under any patents or other right. Application circuits shown, if any, are typical examples illustrating the operation of the devices. Sony cannot assume responsibility for any problems arising out of the use of these circuits.

Pin Description

Pin No.	Symbol	I/O	Equivalent circuit	Description
1	LD	O		APC amplifier output.
2	PD	I		APC amplifier input.
3 4	PD1 PD2	I I		Inversion input for RF I-V amplifiers. Connect these pins to the photodiode A+C and B+D pins respectively. Input the current.
6 7	F E	I I		Inversion input for F and E I-V amplifiers. Connect these pins to the photodiode F and E respectively. Input the current.

Pin No.	Symbol	I/O	Equivalent circuit	Description
8	VR	O		$(V_{CC}+V_{EE})/2$ DC voltage output.
9	VC	I		Center voltage input for VC. Connect this pin to GND for dual $\pm 5V$ power supply; to VR pin for single 5V power supply.
12	EO	O		Monitoring output for I-V amplifier E.
13	EI	—		Gain adjustment for I-V amplifier E.

Pin No.	Symbol	I/O	Equivalent circuit	Description
14	TE	O		Tracking error amplifier output. Outputs the E-F signal.
15	FE-BIAS	I		Bias adjustment for inverted side of focus error amplifier.
16	FE	O		Focus error amplifier output.
17	RFO	O		RF amplifier output.

Pin No.	Symbol	I/O	Equivalent circuit	Description
18	RFI	I		<p>Inverted side input of RF amplifier. RF amplifier gain is determined by the resistor connected between this pin and RFO pin.</p>
19	$\overline{\text{LD-ON}}$	I		<p>APC amplifier ON/OFF switching. ON for GND; OFF for Vcc</p>

±2.5V power supply (V_{CC}=2.5V, V_{EE}=-2.5V, V_C=GND)

Measure- ment No.	Measurement item	Symbol	SW Conditions									Bias conditions			Measure- ment point	Description of output waveform and measurement method	Min.	Typ.	Max.	Unit
			1	2	3	4	5	6	7	8	9	E1	E2	E3						
1	Current consumption	I _{CC}														20	V _{CC} =2.5V, V _{EE} =-2.5V, V _C =0V	8.0	12.0	mA
2		I _{EE}									300mV					5	The followings are the same as above conditions.	-8.0	-	-
3	Offset voltage 1	V ₁₇₋₁								0V					17	V ₁ =2kHz, 400mVpp	-50	0	50	mV
4		Voltage gain	V ₁₇₋₂														V ₁ =3MHz, 400mVpp, ratio to V ₁₇₋₂	5.1	8.1	11.1
5	Frequency response	FV ₁₇₋₂															-3	-	-	dB
6	Maximum output amplitude H	V ₁₇₋₃									0.6V						1.7	-	-	V
7	Maximum output amplitude L	V ₁₇₋₄									-0.6V						-	-	-1.3	V
8	Offset voltage	V ₁₆₋₁													16		-120	0	120	mV
9	Voltage gain 1	V ₁₆₋₂														V ₁ =1kHz, 320mVpp	7.0	10.0	13.0	dB
10	Voltage gain 2	V ₁₆₋₃															7.0	10.0	13.0	dB
11	Voltage gain difference	V ₁₆₋₄														V ₁₇₋₄ =V ₁₇₋₂ -V ₁₇₋₃	-3.0	0	3.0	dB
12	Maximum output amplitude H	V ₁₆₋₅									0.3V						2.0	-	-	V
13	Maximum output amplitude L	V ₁₆₋₆									0.3V						-	-	-2.0	V
14	Offset voltage 1	V ₁₄₋₁													14		-50	0	50	mV
15	Voltage gain 1	V ₁₄₋₂														V ₁ =1kHz, 300mVpp	7.0	10.0	13.0	dB
16	Voltage gain 2	V ₁₄₋₃															7.0	10.0	13.0	dB
17	Voltage gain difference	V ₁₄₋₄														V ₁₋₄ =V ₁₅₋₂ -V ₁₅₋₃	-3.0	0	3.0	dB
18	Maximum output amplitude H	V ₁₄₋₅															2.0	-	-	V
19	Maximum output amplitude L	V ₁₄₋₆									2.0V						-	-	-2.0	V
20	Output voltage 1	V ₁₋₁															-	-1.6	-0.9	V
21	Output voltage 2	V ₁₋₂									69mV						-1.2	0.1	1.4	V
22	Output voltage 3	V ₁₋₃									123mV						0.8	2.1	-	V
23	Output voltage 4	V ₁₋₄									177mV						2.1	2.3	-	V
24	Output voltage 5	V ₁₋₅									0V						-	-	0	V
25	Output voltage 1	V ₆₋₁									0V				8	I ₁ =0.8mA V _{CC} =2.5V V _{EE} =-2.5V V _C =0V	-100	0	100	mV

Electrical Characteristics Measurement Circuit

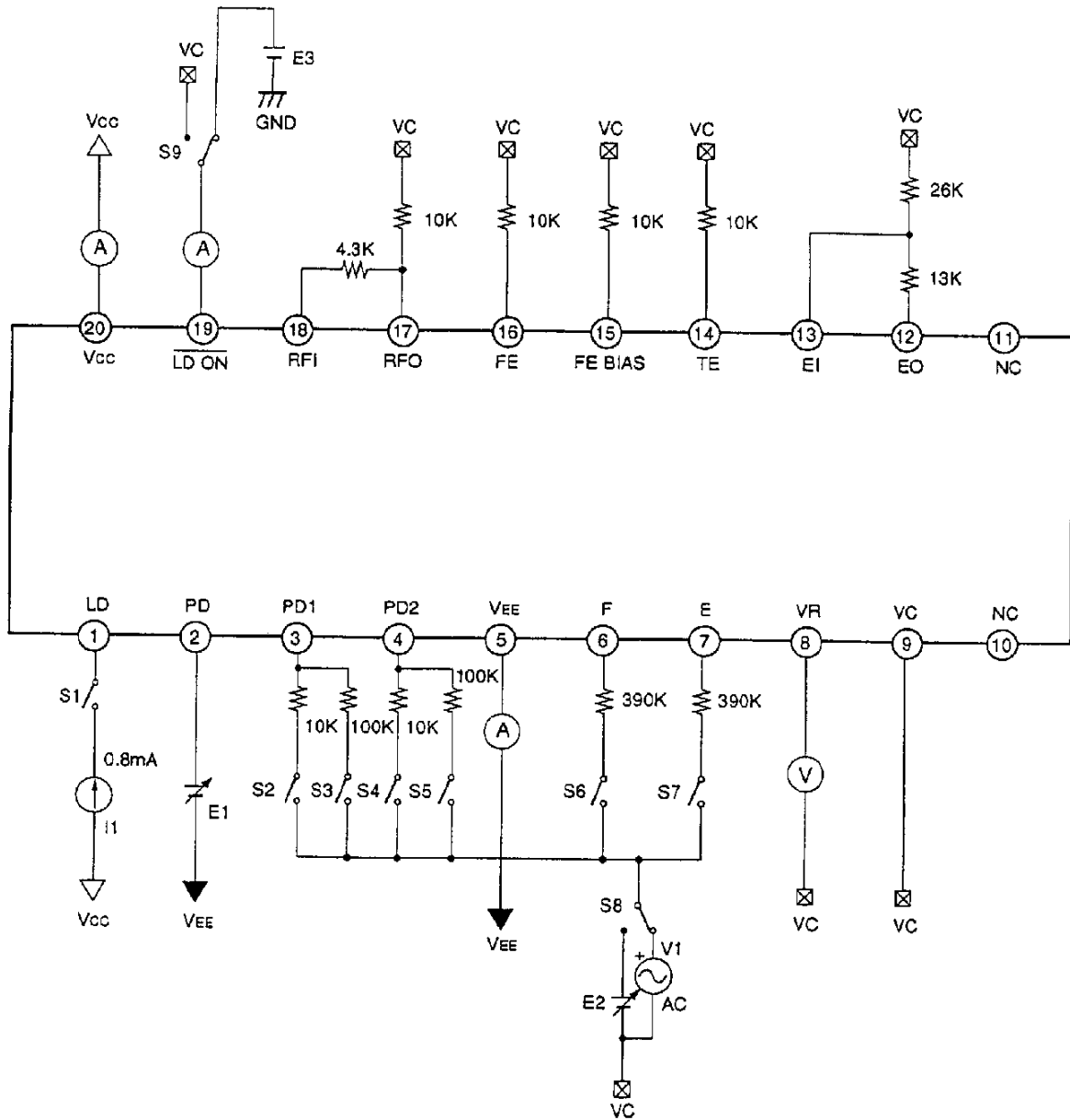

Application Circuit

- For dual $\pm 2.5V$ power supply

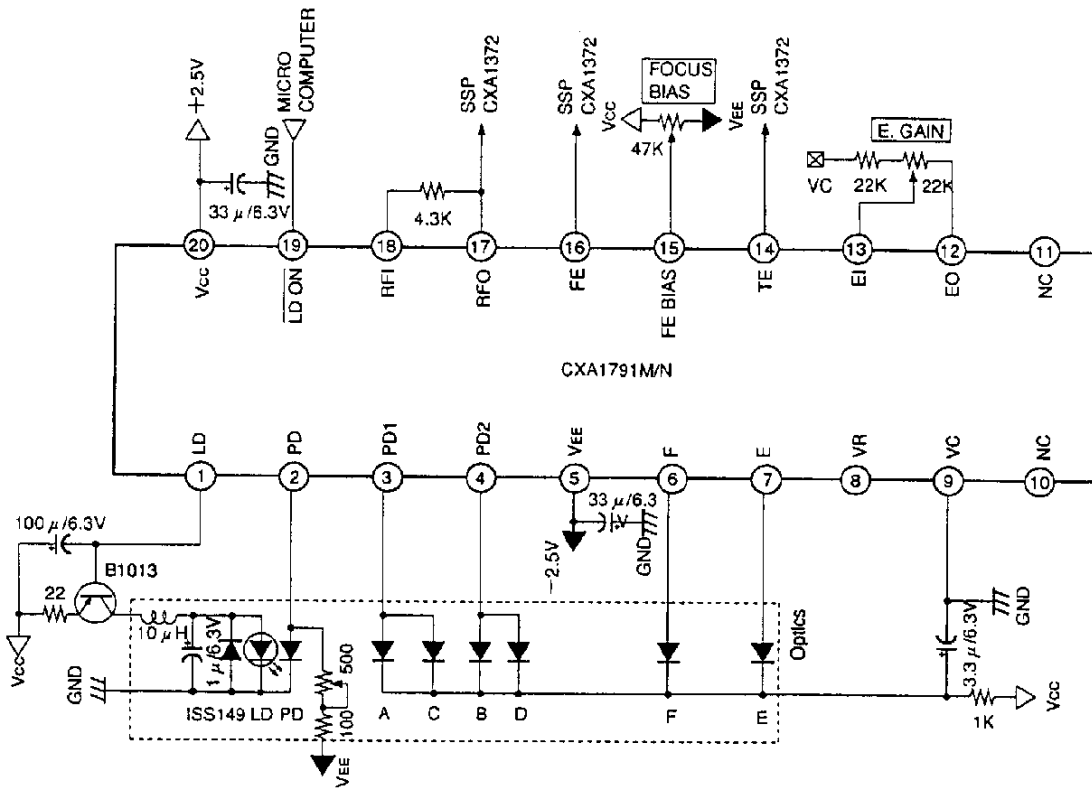

- For single +5V power supply

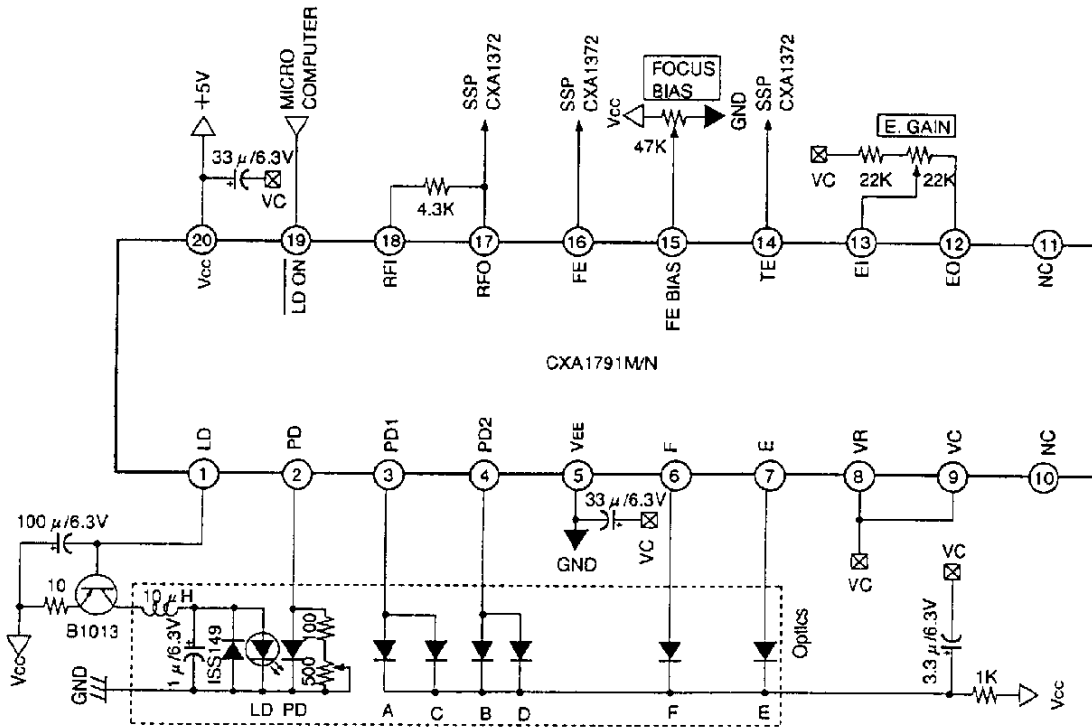

Description of Functions

RF Amplifier

The photodiode current input to input pins (PD1, PD2) is I-V converted at the 58kΩ equivalent resistors, respectively. Then, it is added at the RF summing amplifier and I-V converted output voltage of photodiode (A+B+C+D) is output to RFO pin. This pin can check the eye-pattern.

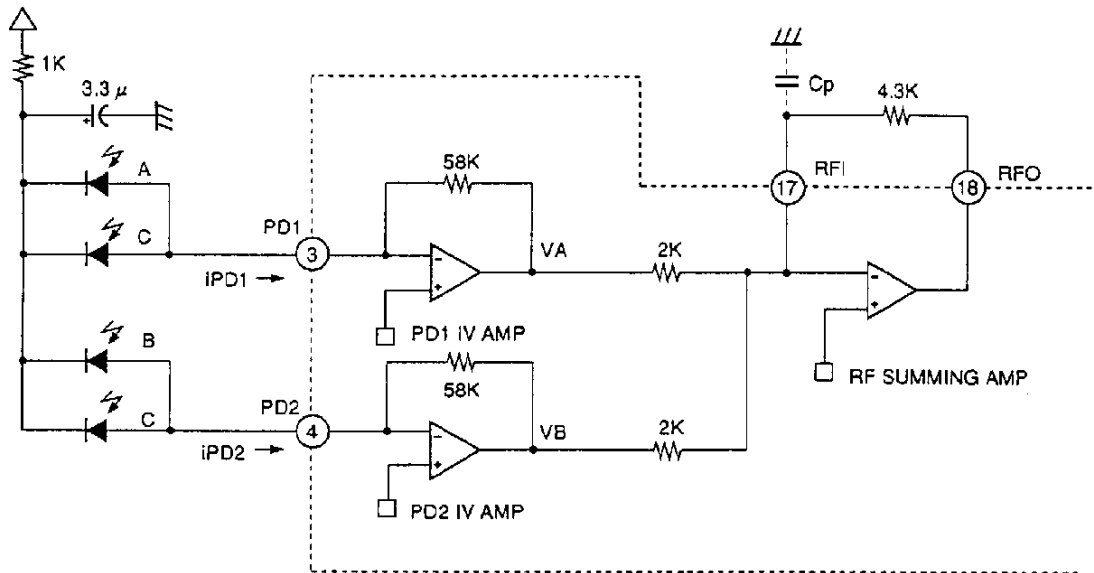

The frequency response of RF output signal can be equalized by adding the capacitor (Cp) to RFI pin. The low frequency component of RFO output voltage is as follows:

$$V_{RFO} = 2.15 \times (V_A + V_B) = 124.7k\Omega \times (i_{PD1} + i_{PD2})$$

Focus Error Amplifier

The difference between RF I-V amplifier outputs VA and VB is obtained, and the I-V converted voltage of photodiode (A+B-C-D) is output.

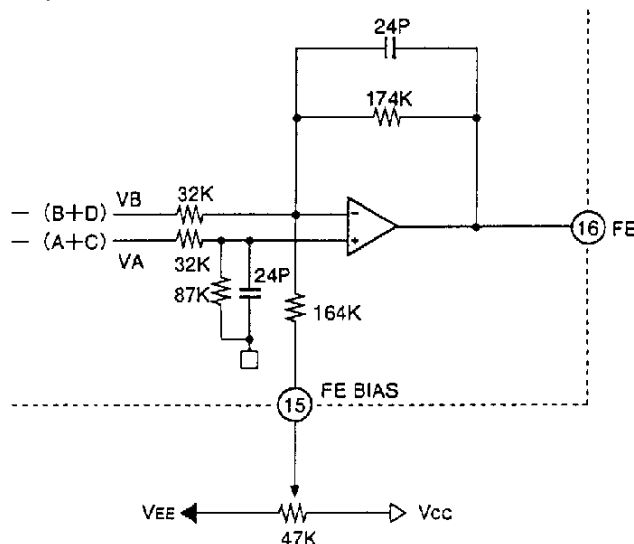

FE output voltage (low frequency component) is as follows:

$$V_{FE} = 5.4 \times (V_A - V_B) = (i_{PD2} - i_{PD1}) \times 315k\Omega$$

Tracking Error Amplifier

The photodiode current input to E and F pins is I-V converted at F IV amplifier.

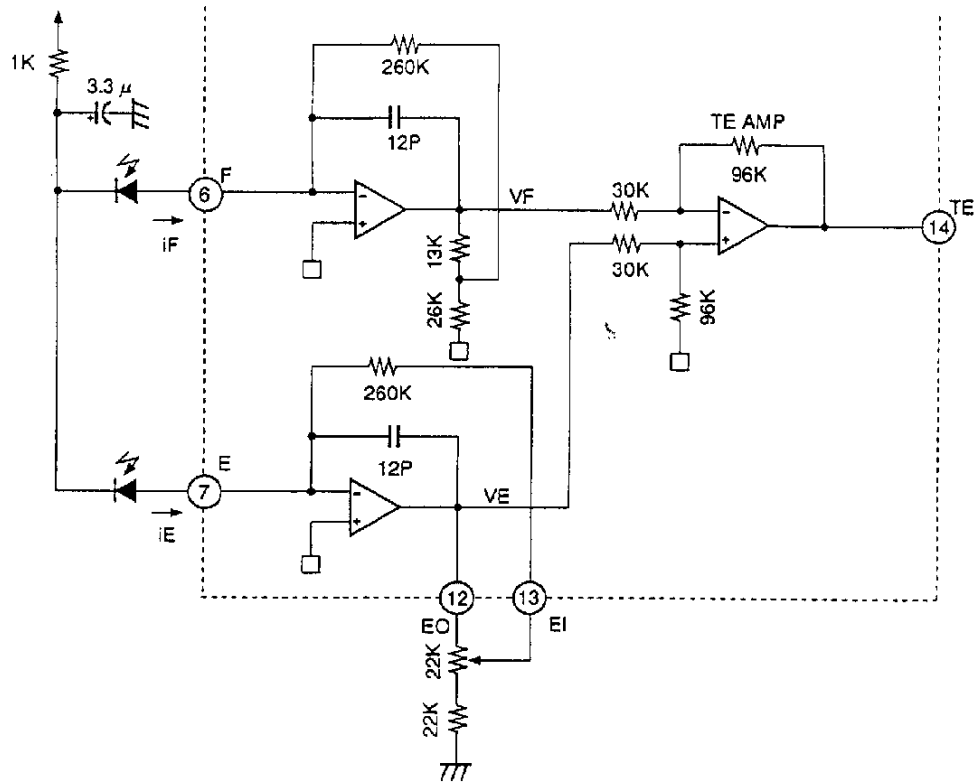

VE and VF difference is obtained at the tracking error amplifier.

$$V_{FE} = (V_E - V_F) \times 3.2$$

$$= (i_F - i_E) \times 1290k\Omega$$

Center Voltage Generation Circuit

The center voltage, used for this IC at single power supply, is supplied. The output impedance is approximately 50Ω.

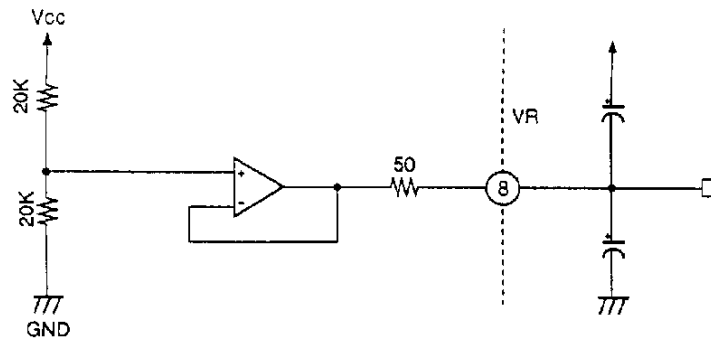

APC Circuit

When driving a constant current, the optical power output by the laser diode possesses large negative temperature characteristics. Therefore, the current must be controlled with the monitor photodiode to ensure the output remains constant. When LD ON pin is connected to GND, APC is ON; connected to Vcc, it is OFF.

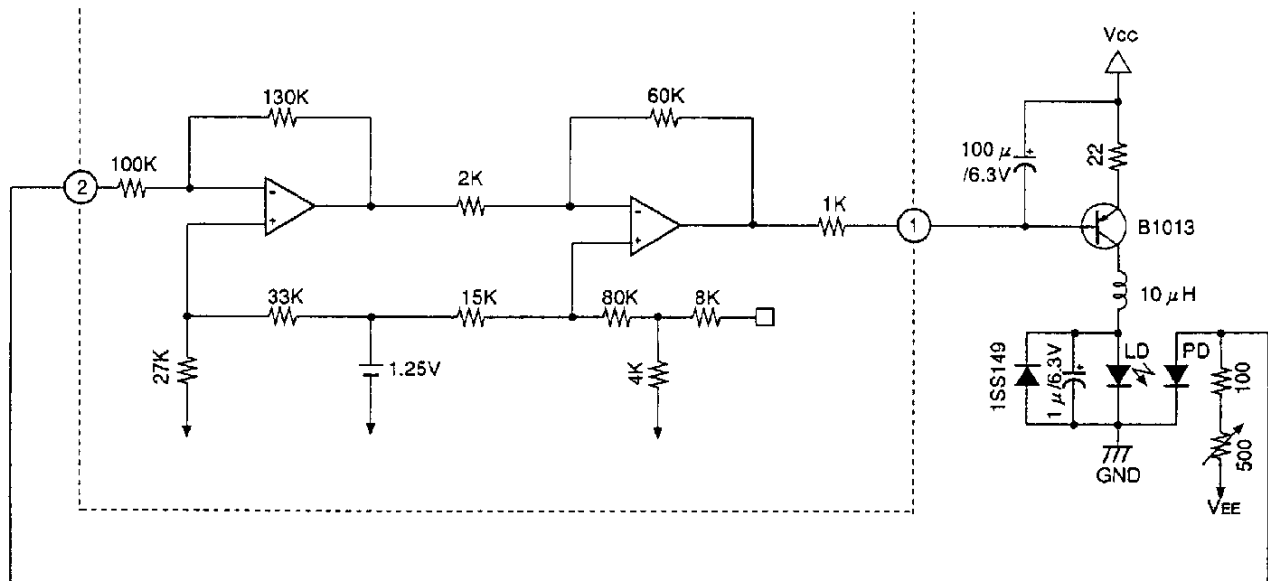

Notes on Operation

1. Power supply

The CXA1791 can be used at dual power supply or single power supply. The connection of power supply for each case is as follows:

	Vcc	VEE	VR	VC
Dual power supply	+power supply	-power supply	OPEN	GND
Single power supply	Power supply	GND	VC	VR

2. RF amplifier

Wiring for PD1 and PD2 input pins should be as short as possible because they are high-impedance. RF band narrows through the capacitance between RFO and RFI.

Package Outline Unit : mm

CXA1791M

20pin SOP (Plastic) 300mil 0.3g

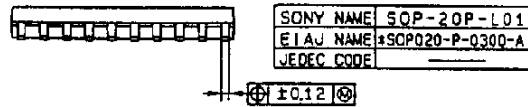
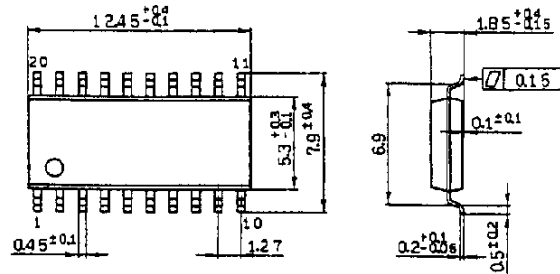

20PIN SSOP (PLASTIC)

CXA1791N

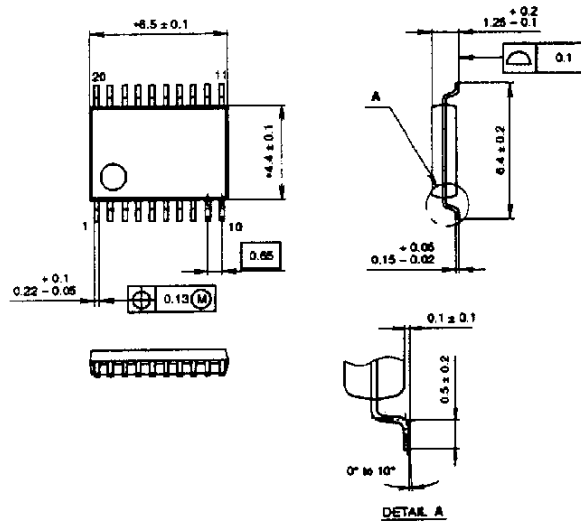

NOTE: Dimension "*" does not include mold protrusion.

SONY CODE	SSOP-20P-L01
EIAJ CODE	SSOP20-P-0044
JEDEC CODE	

PACKAGE STRUCTURE

PACKAGE MATERIAL	EPOXY RESIN
LEAD TREATMENT	SOLDER/PALLADIUM PLATING
LEAD MATERIAL	42/COPPER ALLOY
PACKAGE MASS	0.1g

NOTE : PALLADIUM PLATING

This product uses S-PdPPF (Sony Spec.-Palladium Pre-Plated Lead Frame).