

### FEATURES

- 128K x 8 organization
- Single +5V power supply
- +12.5V programming voltage
- Fast access time: 90/100/120/150 ns
- Totally static operation
- Completely TTL compatible
- Operating current: 30mA
- Standby current: 100uA
- Package type:
  - 32 pin plastic DIP
  - 32 pin PLCC
  - 32 pin SOP
  - 32 pin TSOP

### GENERAL DESCRIPTION

The MX27C1000A is a 5V only, 1M-bit, One Time Programmable Read Only Memory. It is organized as 128K words by 8 bits per word, operates from a single +5 volt supply, has a static standby mode, and features fast single address location programming. All programming signals are TTL levels, requiring a single pulse. For programming outside from the system, existing EPROM

programmers may be used. The MX27C1000A supports an intelligent fast programming algorithm which can result in programming time of less than thirty seconds.

This One Time Programmable Read Only is packaged in industry standard 32 pin dual-in-line packages, 32 lead PLCC, 32 lead SOP and 32 lead TSOP packages.

### PIN CONFIGURATIONS

#### 32 PDIP/SOP

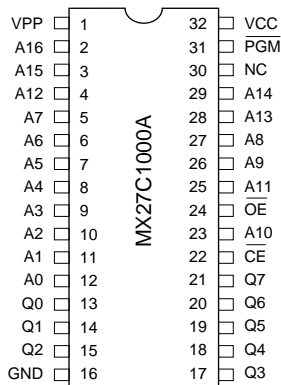

#### 32 PLCC

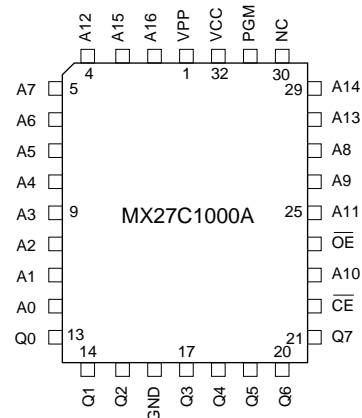

#### 32 TSOP

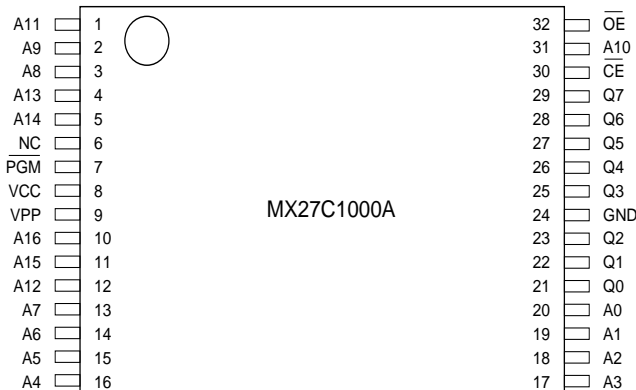

### PIN DESCRIPTION

SYMBOL	PIN NAME
A0~A16	Address Input
Q0~Q7	Data Input/Output
CE	Chip Enable Input
OE	Output Enable Input
PGM	Programmable Enable Input
VPP	Program Supply Voltage
NC	No Internal Connection
VCC	Power Supply Pin (+5V)
GND	Ground Pin

## BLOCK DIAGRAM

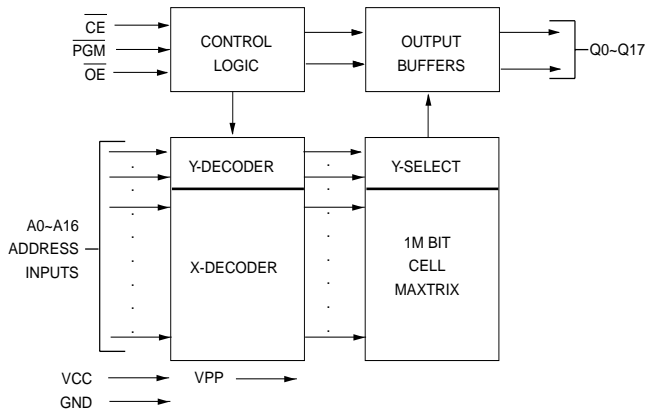

## FUNCTIONAL DESCRIPTION

### THE PROGRAMMING OF THE MX27C1000A

When the MX27C1000A is delivered, or it is erased, the chip has all 1M bits in the "ONE" or HIGH state. "ZEROS" are loaded into the MX27C1000 through the procedure of programming.

For programming, the data to be programmed is applied with 8 bits in parallel to the data pins.

Vcc must be applied simultaneously or before Vpp, and removed simultaneously or after Vpp. When programming an MXIC OTP ROM, a 01.µF capacitor is required across Vpp and ground to suppress spurious voltage transients which may damage the device.

### FAST PROGRAMMING

The device is set up in the fast programming mode when the programming voltage  $V_{PP} = 12.75V$  is applied, with  $V_{CC} = 6.25V$  and  $\overline{PGM} = V_{IL}$  (or  $\overline{OE} = V_{IH}$ ) (Algorithm is shown in Figure 1). The programming is achieved by applying a single TTL low level 10µs pulse to the  $\overline{PGM}$  input after addresses and data line are stable. If the data is not verified, an additional pulse is applied for a maximum of 25 pulses. This process is repeated while sequencing through each address of the device. When the programming mode is completed, the data in all address is verified at  $V_{CC} = V_{PP} = 5V \pm 10\%$ .

### PROGRAM INHIBIT MODE

Programming of multiple MX27C1000As in parallel with different data is also easily accomplished by using the Program Inhibit Mode. Except for  $\overline{CE}$  and  $\overline{OE}$ , all like inputs of the parallel MX27C1000A may be common. A TTL low-level program pulse applied to an MX27C1000A  $\overline{CE}$  input with  $V_{PP} = 12.5 \pm 0.5V$  and  $\overline{PGM} = V_{LOW}$  will program that MX27C1000A. A high-level  $\overline{CE}$  input inhibits the other MX27C1000As from being programmed.

### PROGRAM VERIFY MODE

Verification should be performed on the programmed bits to determine that they were correctly programmed. The verification should be performed with  $\overline{OE}$  and  $\overline{CE}$  at  $V_{IL}$ ,  $\overline{PGM}$  at  $V_{IH}$ , and  $V_{PP}$  at its programming voltage.

### AUTO IDENTIFY MODE

The auto identify mode allows the reading out of a binary code from an EPROM that will identify its manufacturer and device type. This mode is intended for use by programming equipment for the purpose of automatically matching the device to be programmed with its corresponding programming algorithm. This mode is functional in the  $25^\circ C \pm 5^\circ C$  ambient temperature range that is required when programming the MX27C1000A.

To activate this mode, the programming equipment must force  $12.0 \pm 0.5V$  on address line A9 of the device. Two identifier bytes may then be sequenced from the device outputs by toggling address line A0 from  $V_{IL}$  to  $V_{IH}$ . All other address lines must be held at  $V_{IL}$  during auto identify mode.

Byte 0 (A0 =  $V_{IL}$ ) represents the manufacturer code, and byte 1 (A0 =  $V_{IH}$ ), the device identifier code. For the MX27C1000A, these two identifier bytes are given in the Mode Select Table. All identifiers for manufacturer and device codes will possess odd parity, with the MSB (DQ7) defined as the parity bit.

### READ MODE

The MX27C1000A has two control functions, both of which must be logically satisfied in order to obtain data at the outputs. Chip Enable ( $\overline{CE}$ ) is the power control and should be used for device selection. Output Enable

( $\overline{OE}$ ) is the output control and should be used to gate data to the output pins, independent of device selection. Assuming that addresses are stable, address access time ( $t_{ACC}$ ) is equal to the delay from  $\overline{CE}$  to output ( $t_{CE}$ ). Data is available at the outputs  $t_{QE}$  after the falling edge of  $\overline{OE}$ , assuming that  $\overline{CE}$  has been LOW and addresses have been stable for at least  $t_{ACC} - t_{QE}$ .

## STANDBY MODE

The MX27C1000A has a CMOS standby mode which reduces the maximum VCC current to 100  $\mu$ A. It is placed in CMOS standby when  $\overline{CE}$  is at  $V_{CC} \pm 0.3$  V. The MX27C1000A also has a TTL-standby mode which reduces the maximum VCC current to 1.5 mA. It is placed in TTL-standby when  $\overline{CE}$  is at  $V_{IH}$ . When in standby mode, the outputs are in a high-impedance state, independent of the  $\overline{OE}$  input.

## TWO-LINE OUTPUT CONTROL FUNCTION

To accommodate multiple memory connections, a two-line control function is provided to allow for:

1. Low memory power dissipation,
2. Assurance that output bus contention will not occur.

It is recommended that  $\overline{CE}$  be decoded and used as the primary device-selecting function, while  $\overline{OE}$  be made a common connection to all devices in the array and connected to the READ line from the system control bus. This assures that all deselected memory devices are in their low-power standby mode and that the output pins are only active when data is desired from a particular memory device.

## SYSTEM CONSIDERATIONS

During the switch between active and standby conditions, transient current peaks are produced on the rising and falling edges of Chip Enable. The magnitude of these transient current peaks is dependent on the output capacitance loading of the device. At a minimum, a 0.1  $\mu$ F ceramic capacitor (high frequency, low inherent inductance) should be used on each device between VCC and GND to minimize transient effects. In addition, to overcome the voltage drop caused by the inductive effects of the printed circuit board traces on EPROM arrays, a 4.7  $\mu$ F bulk electrolytic capacitor should be used between VCC and GND for each eight devices. The location of the capacitor should be close to where the power supply is connected to the array.

## MODE SELECT TABLE

MODE	$\overline{CE}$	$\overline{OE}$	$\overline{PGM}$	PINS		VPP	OUTPUTS
				A0	A9		
Read	VIL	VIL	X	X	X	VCC	DOUT
Output Disable	VIL	$V_{IH}$	X	X	X	VCC	High Z
Standby (TTL)	$V_{IH}$	X	X	X	X	VCC	High Z
Standby (CMOS)	$V_{CC} \pm 0.3V$	X	X	X	X	VCC	High Z
Program	VIL	$V_{IH}$	VIL	X	X	VPP	DIN
Program Verify	VIL	VIL	$V_{IH}$	X	X	VPP	DOUT
Program Inhibit	$V_{IH}$	X	X	X	X	VPP	High Z
Manufacturer Code(3)	VIL	VIL	X	VIL	$V_H$	VCC	C2H
Device Code(27C1000)(3)	VIL	VIL	X	$V_{IH}$	$V_H$	VCC	CAH

### NOTES:

1.  $V_H = 12.0$  V  $\pm$  0.5 V
2. X = Either  $V_{IH}$  or VIL
3. A1 - A8 = A10 - A16 = VIL(For auto select)
4. See DC Programming Characteristics for VPP voltage during programming.

**FIGURE 1. FAST PROGRAMMING FLOWCHART**

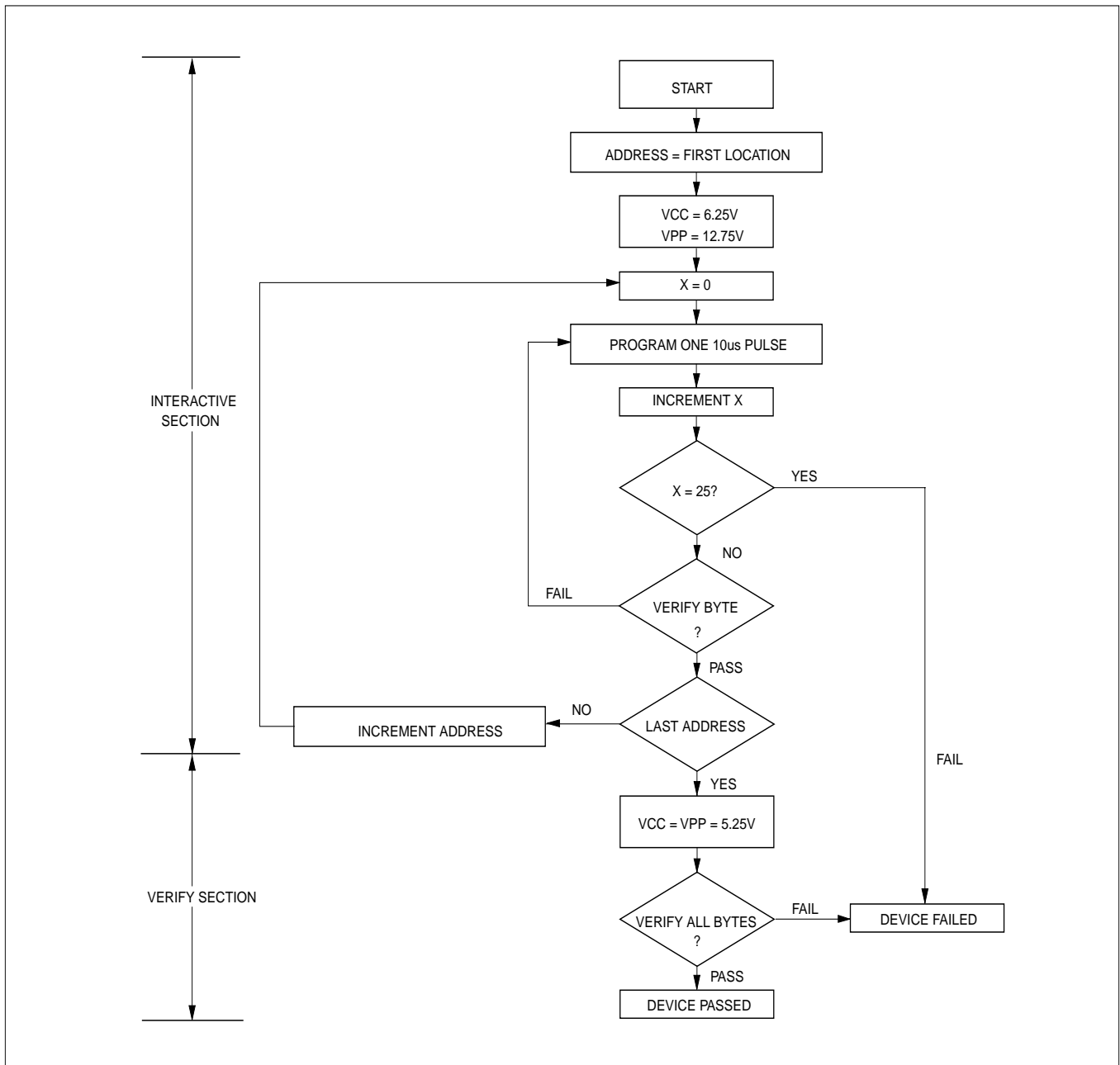

## SWITCHING TEST CIRCUITS

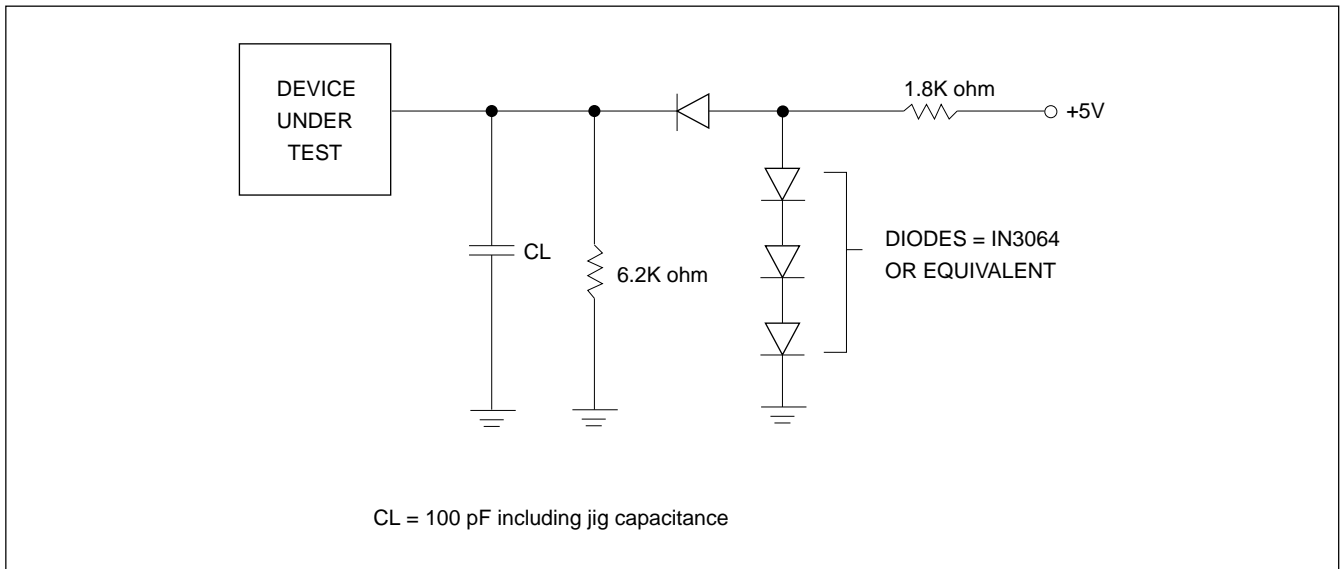

## SWITCHING TEST WAVEFORMS

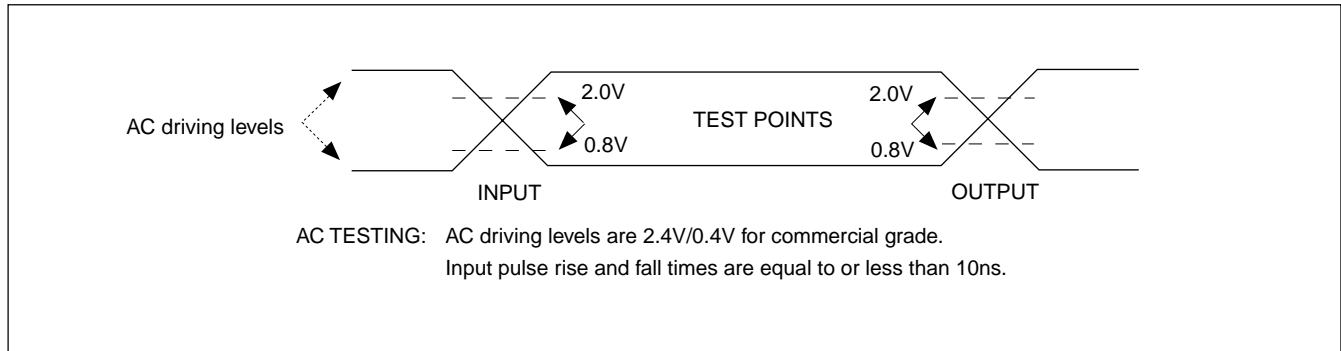

**ABSOLUTE MAXIMUM RATINGS**

RATING	VALUE
Ambient Operating Temperature	-40°C to 85°C
Storage Temperature	-65°C to 125°C
Applied Input Voltage	-0.5V to 7.0V
Applied Output Voltage	-0.5V to VCC + 0.5V
VCC to Ground Potential	-0.5V to 7.0V
A9 & Vpp	-0.5V to 13.5V

**NOTICE:**

Stresses greater than those listed under ABSOLUTE MAXIMUM RATINGS may cause permanent damage to the device. This is a stress rating only and functional operation of the device at these or any other conditions above those indicated in the operational sections of this specification is not implied. Exposure to absolute maximum rating conditions for extended period may affect reliability.

**NOTICE:**

Specifications contained within the following tables are subject to change.

**DC/AC Operating Condition for Read Operation**

		<b>MX27C1000A</b>			
		<b>-90</b>	<b>-10</b>	<b>-12</b>	<b>-15</b>
Operating Temperature	Industrial	-40°C to 85°C	-40°C to 85°C	-40°C to 85°C	-40°C to 85°C
Vcc Power Supply		5V ± 10%	5V ± 10%	5V ± 10%	5V ± 10%

**DC CHARACTERISTICS**

SYMBOL	PARAMETER	MIN.	MAX.	UNIT	CONDITIONS
VOH	Output High Voltage	2.4		V	IOH = -0.4mA
VOL	Output Low Voltage		0.4	V	IOL = 2.1mA
VIH	Input High Voltage	2.0	VCC + 0.5	V	
VIL	Input Low Voltage	-0.2	0.8	V	
ILI	Input Leakage Current	-10	10	uA	VIN = 0 to 5.5V
ILO	Output Leakage Current	-10	10	uA	VOUT = 0 to 5.5V
ICC3	VCC Power-Down Current		100	uA	$\overline{CE} = VCC \pm 0.3V$
ICC2	VCC Standby Current		1.5	mA	$\overline{CE} = VIH$
ICC1	VCC Active Current		30	mA	$\overline{CE} = VIL, f=5MHz, Iout = 0mA$
IPP	VPP Supply Current Read		10	uA	$\overline{CE} = VIL, VPP = 5.5V$

**CAPACITANCE** TA = 25°C, f = 1.0 MHz (Sampled only)

SYMBOL	PARAMETER	MIN.	MAX.	UNIT	CONDITIONS
CIN	Input Capacitance	8	12	pF	VIN = 0V
COUT	Output Capacitance	8	12	pF	VOUT = 0V
Vpp	VPP Capacitance	18	25	pF	VPP = 0V

**AC CHARACTERISTICS**

Symbol	PARAMETER	27C1000A-90		27C1000A-10		27C1000A-12		27C1000A-15		Unit	Conditions
		MIN.	MAX.	MIN.	MAX.	MIN.	MAX.	MIN.	MAX.		
tACC	Address to Output Delay		90		100		120		150	ns	$\overline{CE}=\overline{OE}=\text{VIL}$
tCE	Chip Enable to Output Delay		90		100		120		150	ns	$\overline{OE}=\text{VIL}$
tOE	Output Enable to Output Delay		40		45		50		65	ns	$\overline{CE}=\text{VIL}$
tDF	$\overline{OE}$ High to Output Float, or $\overline{CE}$ High to Output Float	0	25	0	35	0	35	0	50	ns	
tOH	Output Hold from Address, $\overline{CE}$ or $\overline{OE}$ which ever occurred first	0		0		0		0		ns	

**DC PROGRAMMING CHARACTERISTICS** TA = 25°C ± 5°C

SYMBOL	PARAMETER	MIN.	MAX.	UNIT	CONDITIONS
VOH	Output High Voltage	2.4		V	IOH = -0.40mA
VOL	Output Low Voltage		0.4	V	IOL = 2.1mA
VIH	Input High Voltage	2.0	VCC + 0.5	V	
VIL	Input Low Voltage	-0.3	0.8	V	
ILI	Input Leakage Current	-10	10	uA	VIN = 0 to 5.5V
VH	A9 Auto Select Voltage	11.5	12.5	V	
ICC3	VCC Supply Current (Program & Verify)		50	mA	
IPP2	VPP Supply Current(Program)		30	mA	$\overline{CE} = \text{PGM} = \text{VIL}$ , $\overline{OE} = \text{VIH}$
VCC1	Fast Programming Supply Voltage	6.00	6.50	V	
VPP1	Fast Programming Voltage	12.5	13.0	V	

**AC PROGRAMMING CHARACTERISTICS** TA = 25°C ± 5°C

SYMBOL	PARAMETER	MIN.	MAX.	UNIT	CONDITIONS
tAS	Address Setup Time	2.0		us	
tOES	$\overline{OE}$ Setup Time	2.0		us	
tDS	Data Setup Time	2.0		us	
tAH	Address Hold Time	0		us	
tDH	Data Hold Time	2.0		us	
tDFP	Output Enable to Output Float Delay	0	130	ns	
tVPS	VPP Setup Time	2.0		us	
tPW	$\overline{PGM}$ Program Pulse Width	10	50	us	
tVCS	VCC Setup Time	2.0		us	
tCES	$\overline{CE}$ Setup Time	2.0		us	
tOE	Data valid from $\overline{OE}$		150	ns	

## WAVEFORMS

### READ CYCLE

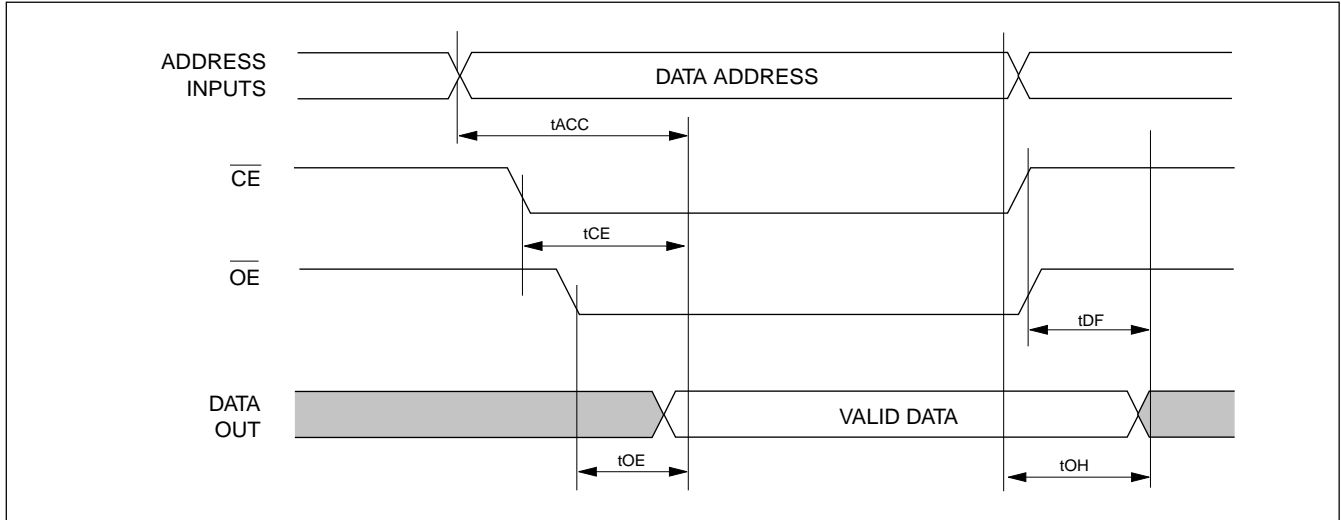

### FAST PROGRAMMING ALGORITHM WAVEFORMS

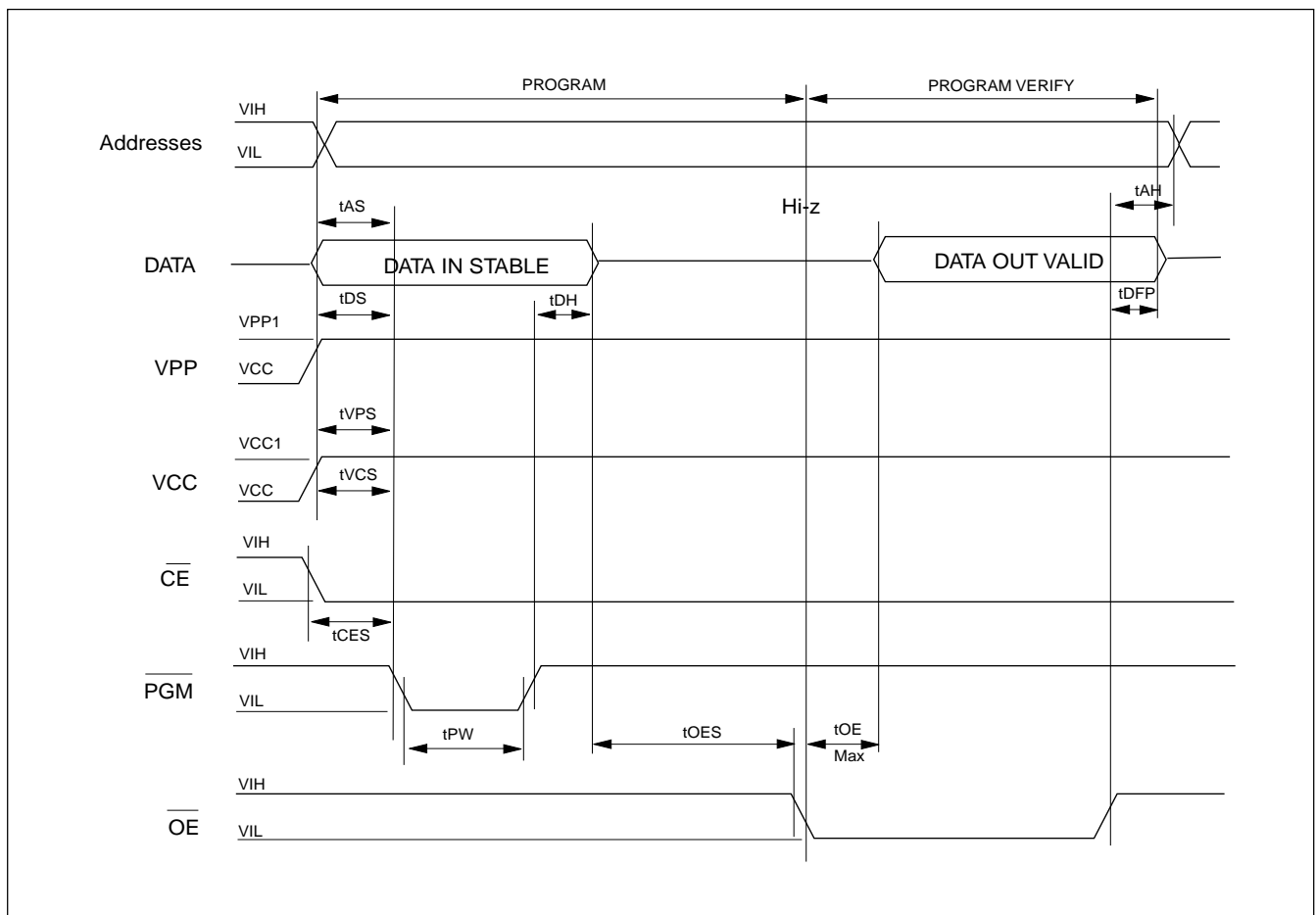



**ORDERING INFORMATION**
**PLASTIC PACKAGE**

PART NO.	ACCESS TIME(ns)	OPERATING	STANDBY	OPERATING	PACKAGE
		Current MAX.(mA)	Current MAX.(uA)	TEMPERATURE	
MX27C1000APC-90	90	30	100	0°C to 70°C	32 Pin DIP
MX27C1000AQC-90	90	30	100	0°C to 70°C	32 Pin PLCC
MX27C1000AMC-90	90	30	100	0°C to 70°C	32 Pin SOP
MX27C1000ATC-90	90	30	100	0°C to 70°C	32 Pin TSOP
MX27C1000APC-10	100	30	100	0°C to 70°C	32 Pin DIP
MX27C1000AQC-10	100	30	100	0°C to 70°C	32 Pin PLCC
MX27C1000AMC-10	100	30	100	0°C to 70°C	32 Pin SOP
MX27C1000ATC-10	100	30	100	0°C to 70°C	32 Pin TSOP
MX27C1000APC-12	120	30	100	0°C to 70°C	32 Pin DIP
MX27C1000AQC-12	120	30	100	0°C to 70°C	32 Pin PLCC
MX27C1000AMC-12	120	30	100	0°C to 70°C	32 Pin SOP
MX27C1000ATC-12	120	30	100	0°C to 70°C	32 Pin TSOP
MX27C1000APC-15	150	30	100	0°C to 70°C	32 Pin DIP
MX27C1000AQC-15	150	30	100	0°C to 70°C	32 Pin PLCC
MX27C1000AMC-15	150	30	100	0°C to 70°C	32 Pin SOP
MX27C1000ATC-15	150	30	100	0°C to 70°C	32 Pin TSOP
MX27C1000API-90	90	30	100	-40°C to 85°C	32 Pin DIP
MX27C1000AQI-90	90	30	100	-40°C to 85°C	32 Pin PLCC
MX27C1000AMI-90	90	30	100	-40°C to 85°C	32 Pin SOP
MX27C1000ATI-90	90	30	100	-40°C to 85°C	32 Pin TSOP
MX27C1000API-10	100	30	100	-40°C to 85°C	32 Pin DIP
MX27C1000AQI-10	100	30	100	-40°C to 85°C	32 Pin PLCC
MX27C1000AMI-10	100	30	100	-40°C to 85°C	32 Pin SOP
MX27C1000ATI-10	100	30	100	-40°C to 85°C	32 Pin TSOP
MX27C1000API-12	120	30	100	-40°C to 85°C	32 Pin DIP
MX27C1000AQI-12	120	30	100	-40°C to 85°C	32 Pin PLCC
MX27C1000AMI-12	120	30	100	-40°C to 85°C	32 Pin SOP
MX27C1000ATI-12	120	30	100	-40°C to 85°C	32 Pin TSOP
MX27C1000API-15	150	30	100	-40°C to 85°C	32 Pin DIP
MX27C1000AQI-15	150	30	100	-40°C to 85°C	32 Pin PLCC
MX27C1000AMI-15	150	30	100	-40°C to 85°C	32 Pin SOP
MX27C1000ATI-15	150	30	100	-40°C to 85°C	32 Pin TSOP

## PACKAGE INFORMATION

**Title:** Package Outline for PDIP 32L(600MIL)

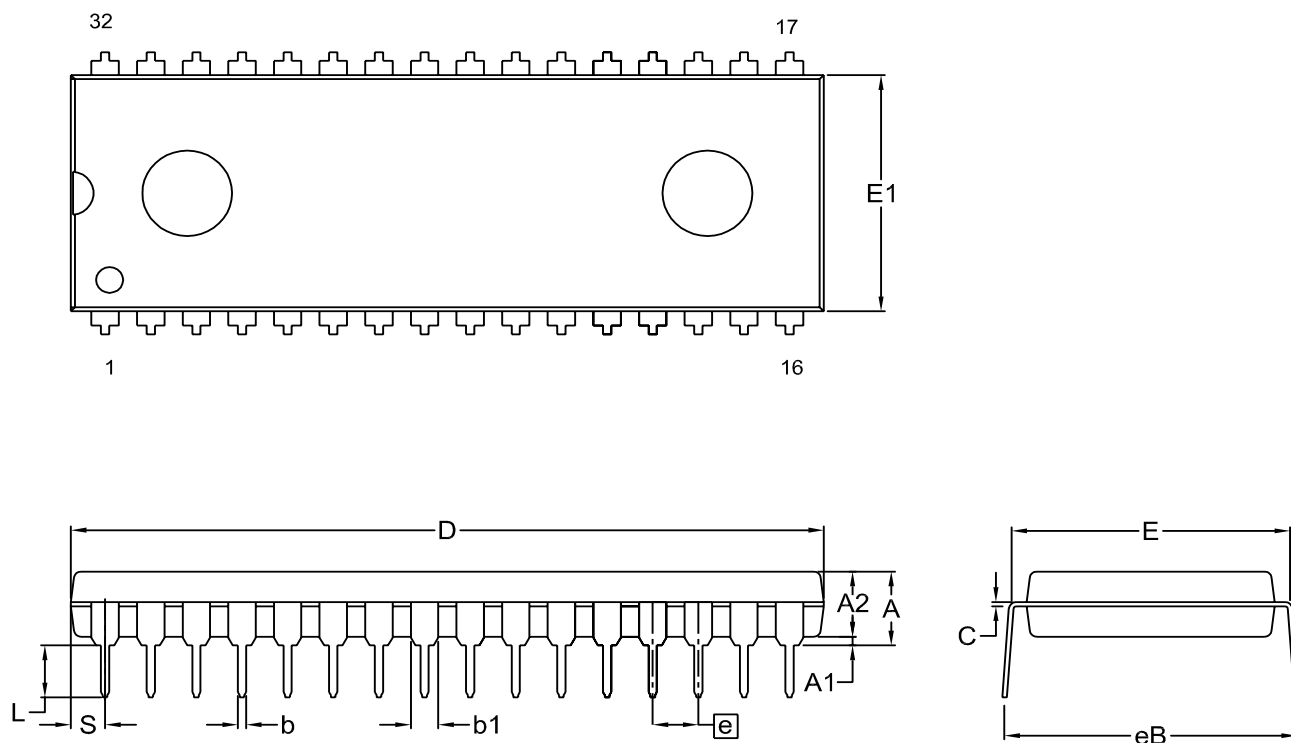

Dimensions (inch dimensions are derived from the original mm dimensions)

SYMBOL		A	A1	A2	b	b1	C	D	E	E1	e	eB	L	S
UNIT														
mm	Min.	---	0.38	3.73	0.38	1.14	0.20	41.78	15.11	13.84		15.75	2.92	1.65
	Nom.	---	---	3.94	0.46	1.27	0.25	41.91	15.24	13.97	2.54	16.51	3.30	1.90
	Max.	4.90	0.76	4.14	0.53	1.40	0.30	42.04	15.37	14.10		17.27	3.68	2.16
Inch	Min.	---	0.015	0.147	0.015	0.045	0.008	1.645	0.595	0.545		0.620	0.115	0.065
	Nom.	---	---	0.155	0.018	0.050	0.010	1.650	0.600	0.550	0.100	0.650	0.130	0.075
	Max.	0.193	0.030	0.163	0.021	0.055	0.012	1.655	0.605	0.555		0.680	0.145	0.085

DWG.NO.	REVISION	REFERENCE			ISSUE DATE
		JEDEC	EIAJ		
6110-0202.2	6				11-19-'02

**Title: Package Outline for SOP 32L (450MIL)**

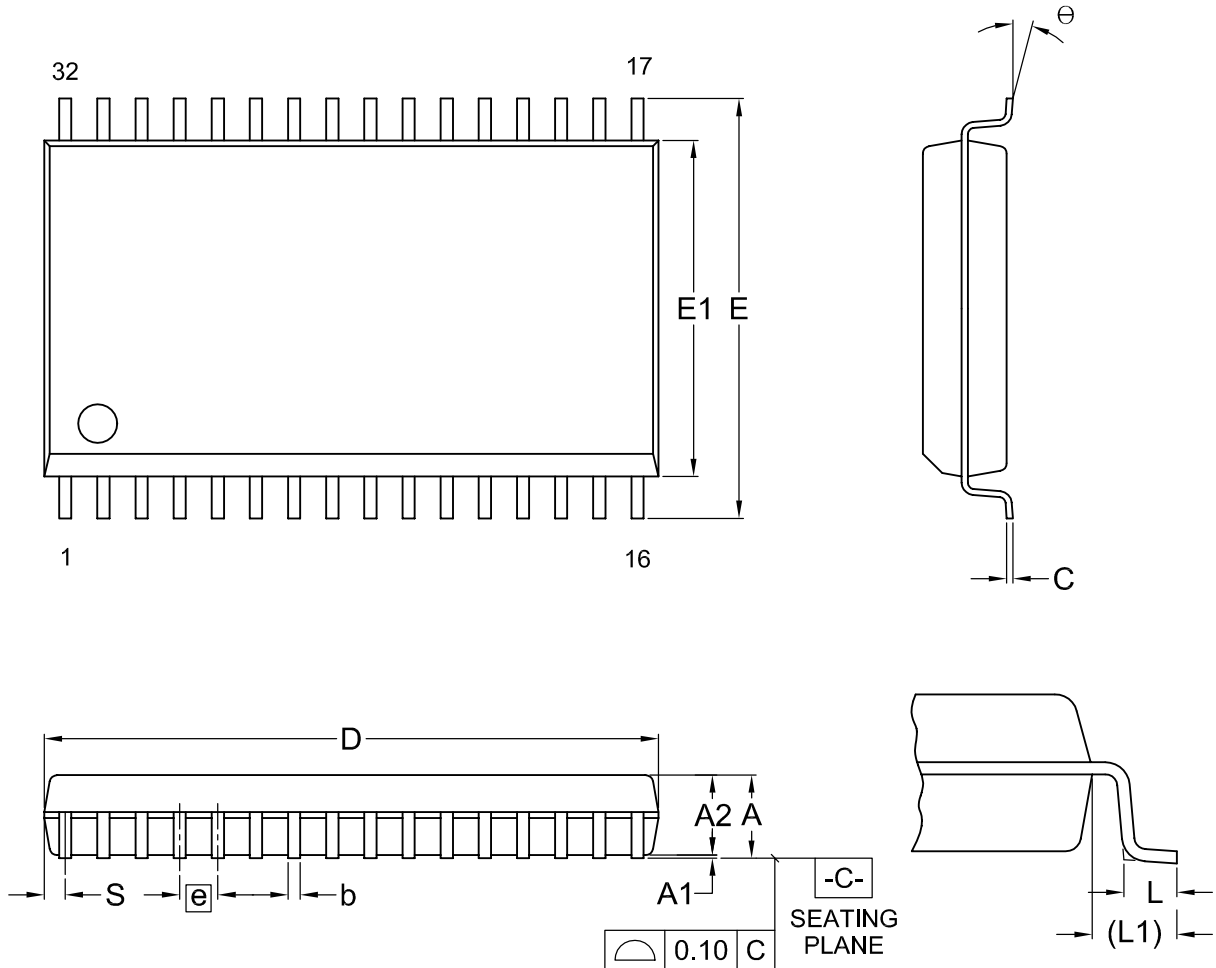

Dimensions (inch dimensions are derived from the original mm dimensions)

SYMBOL		A	A1	A2	b	C	D	E	E1	e	L	L1	S	$\theta$
UNIT														
mm	Min.	---	0.10	2.59	0.36	0.15	20.32	13.92	11.18		0.56	1.20	0.58	0
	Nom.	---	0.15	2.69	0.41	0.20	20.45	14.12	11.30	1.27	0.76	1.40	0.70	5
	Max.	3.00	0.20	2.80	0.51	0.25	20.57	14.32	11.43		0.96	1.60	0.83	8
Inch	Min.	---	0.004	0.102	0.014	0.006	0.800	0.548	0.440		0.022	0.047	0.023	0
	Nom.	---	0.006	0.106	0.016	0.008	0.805	0.556	0.445	0.050	0.030	0.055	0.028	5
	Max.	0.118	0.008	0.110	0.020	0.010	0.810	0.564	0.450		0.038	0.063	0.033	8

DWG.NO.	REVISION	REFERENCE			ISSUE DATE
		JEDEC	EIAJ		
6110-1404	4	MO-099			09-24-'02

**Title: Package Outline for 32L PLCC**

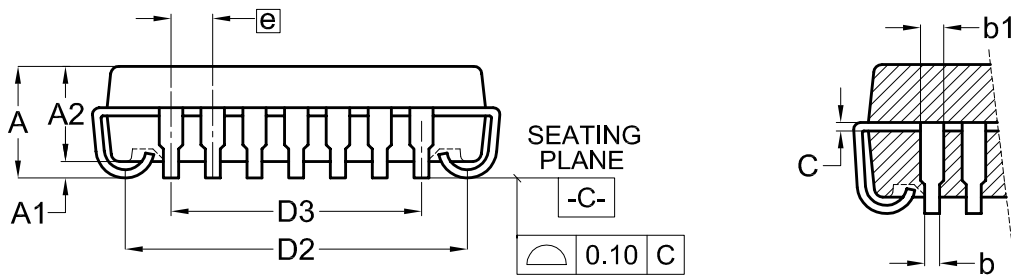
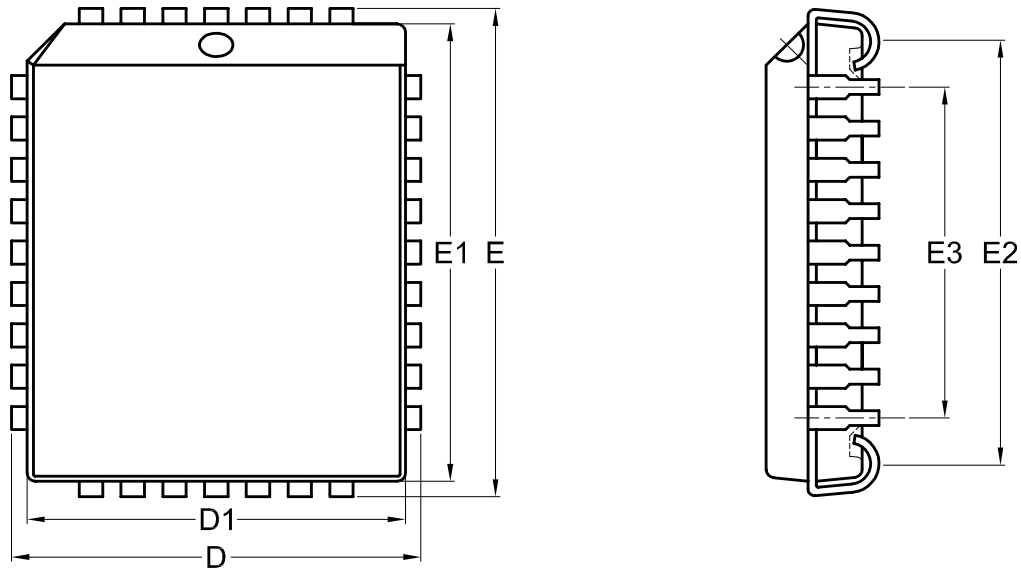

Dimensions (inch dimensions are derived from the original mm dimensions)

SYMBOL		A	A1	A2	b	b1	C	D	D1	D2	D3	E	E1	E2	E3	e
mm	Min.	---	0.38	2.69	0.38	0.61	0.20	12.32	11.36	10.11		14.86	13.98	12.65		
	Nom.	---	0.58	2.79	0.46	0.71	0.25	12.45	11.43	10.41	7.62	14.99	14.05	12.95	10.16	1.27
	Max.	3.55	0.81	2.89	0.54	0.81	0.30	12.58	11.50	10.71		15.12	14.12	13.25		
Inch	Min.	---	0.015	0.106	0.015	0.024	0.008	0.485	0.447	0.398		0.585	0.550	0.498		
	Nom.	---	0.023	0.110	0.018	0.028	0.010	0.490	0.450	0.410	0.300	0.590	0.553	0.510	0.400	0.050
	Max.	0.140	0.032	0.114	0.021	0.032	0.012	0.495	0.453	0.422		0.595	0.556	0.522		

DWG.NO.	REVISION	REFERENCE			ISSUE DATE
		JEDEC	EIAJ		
6110-2002	6	MS-016			08-15-'03

## Title: Package Outline for TSOP(I) 32L (8X20mm)

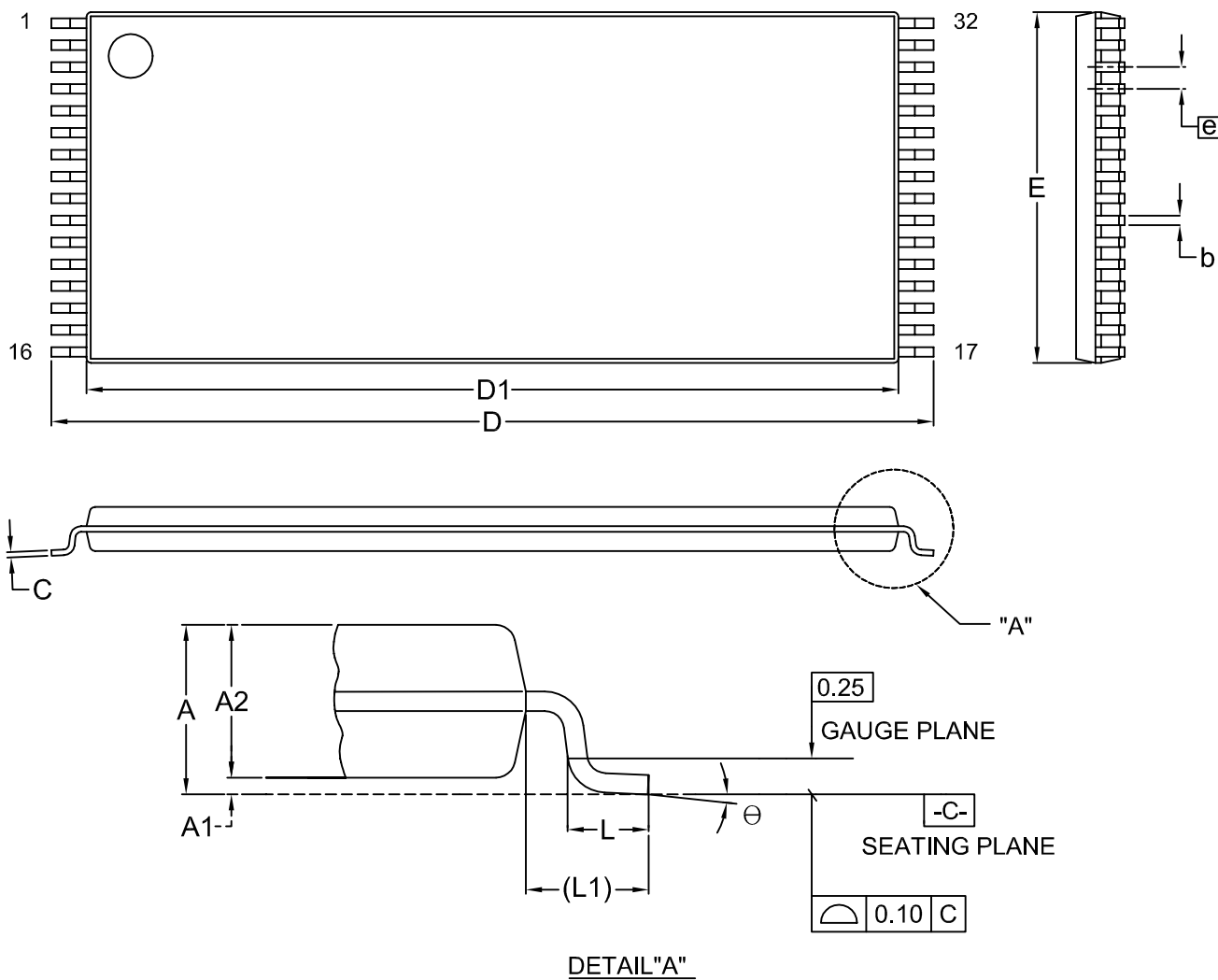

Dimensions (inch dimensions are derived from the original mm dimensions)

SYMBOL		A	A1	A2	b	C	D	D1	E	e	L	L1	θ
UNIT													
mm	Min.	---	0.05	0.95	0.17	0.10	19.80	18.30	7.90		0.50	0.70	0
	Nom.	---	0.10	1.00	0.20	0.15	20.00	18.40	8.00	0.50	0.60	0.80	5
	Max.	1.20	0.15	1.05	0.27	0.21	20.20	18.50	8.10		0.70	0.90	8
Inch	Min.	---	0.002	0.037	0.007	0.004	0.780	0.720	0.311		0.020	0.028	0
	Nom.	---	0.004	0.039	0.008	0.006	0.787	0.724	0.315	0.020	0.024	0.031	5
	Max.	0.047	0.006	0.041	0.011	0.008	0.795	0.728	0.319		0.028	0.035	8

DWG.NO.	REVISION	REFERENCE			ISSUE DATE
		JEDEC	EIAJ		
6110-1604	8	MO-142			09-24-'02

**REVISION HISTORY**

<b>Revision No.</b>	<b>Description</b>	<b>Page</b>	<b>Date</b>
1.0	To change data sheet title to Preliminary	P1	MAR/13/2001
	To added access time 100/150ns and 32SOP/TSOP type package	P1,6,7,9	
1.1	To modify Package Information	P10~13	JUL/19/2001
1.2	To modify Package Information	P10~13	NOV/19/2002
1.3	To modify 32-PLCC package information	P12	AUG/27/2003
	A1: from 0.50mm(0.020 inch)/nom. to 0.58mm(0.023 inch)/nom. from 0.66mm(0.026 inch)/nom. to 0.81mm(0.032 inch)/nom.		



**MX27C1000A**

---

---

**MACRONIX INTERNATIONAL Co., LTD.**

**HEADQUARTERS:**

TEL:+886-3-578-6688

FAX:+886-3-563-2888

**EUROPE OFFICE:**

TEL:+32-2-456-8020

FAX:+32-2-456-8021

**JAPAN OFFICE:**

TEL:+81-44-246-9100

FAX:+81-44-246-9105

**SINGAPORE OFFICE:**

TEL:+65-348-8385

FAX:+65-348-8096

**TAIPEI OFFICE:**

TEL:+886-2-2509-3300

FAX:+886-2-2509-2200

**MACRONIX AMERICA, INC.**

TEL:+1-408-453-8088

FAX:+1-408-453-8488

**CHICAGO OFFICE:**

TEL:+1-847-963-1900

FAX:+1-847-963-1909

**[http : //www.macronix.com](http://www.macronix.com)**

---