

MAS9011

This is preliminary information on a new product under development. Micro Analog Systems Oy reserves the right to make any changes without notice.

Preliminary

Solar Cell System Manager

- Power On Indicator
- Low Battery Indicator
- Battery Overcharging Protection

DESCRIPTION

The solar cell system manager is an analog circuit, which monitors the supply voltage of a battery-powered system containing solar cells. The solar manager uses three output signals to indicate the state of the system. Power On (PO) indicates whether the supply voltage is high enough to run

the system. Low Battery (LB) is used to signal the situation where the battery is low. The third signal, SOL, is used for battery charging control. It indicates when the battery is full and the charging process should be stopped.

FEATURES

- Power On Indicator
- Low Battery Indicator
- Battery Overcharging Protection

APPLICATIONS

- Solar Cell Powered Watch

BLOCK DIAGRAM

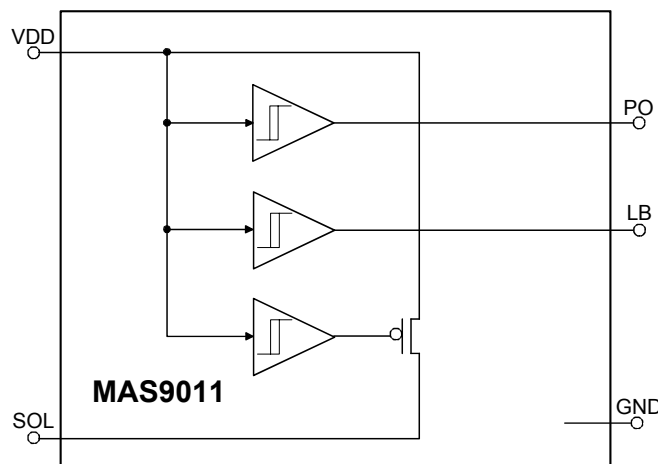

PAD LAYOUT

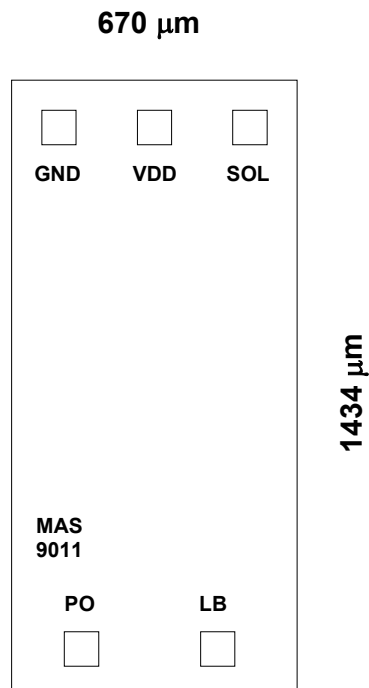

DIE size = 0.67 mm x 1.43 mm
PAD size = 80 x 80 μm

Note: Make sure that VDD is the first pad to be bonded. Pick-and-place and all component assembly are recommended to be performed in ESD protected area.

Note: If the die is to be placed on metal plane, the metal plane should be connected to VDD or left floating. This because the substrate of the die is internally connected to VDD.

Note: Coordinates are pad center points where origin has been located in bottom-left corner of the silicon die.

Pad Identification	Name	X-coordinate	Y-coordinate
Power Supply Ground	GND	174 μm	1208 μm
Power Supply Voltage	VDD	334 μm	1210 μm
Full Battery Output	SOL	495 μm	1221 μm
Power On Output	PO	211 μm	221 μm
Low Battery Output	LB	462 μm	221 μm

FUNCTIONAL DESCRIPTION

The solar manager generates three signals: PO (Power On), LB (Low Battery) and SOL (Full Battery).

These signals are produced by three comparators which have hysteresis build in. Each comparator compares supply voltage (VDD) to internal switching levels (see Electrical Characteristics on next page). The current consumption of the comparators is very low. The electrical parameters are described more detailed in the Electrical Characteristics chapter.

PO signal can be used to stop the whole system whenever the power supply level has dropped low enough. When power supply voltage is too low, the PO goes high to give signal to watch microcontroller to go power down.

LB signal indicates that the battery is low but not empty. LB goes high when power supply level is too low.

SOL is used for battery charging control of the solar watch. When power supply voltage goes high enough, the internal PMOS switch between VDD and SOL pins is switched on to shunt the solar cell charging current and to prevent battery overcharging.

In operation without an external Schottky diode between the pins SOL and GND, the voltage at pin SOL is clamped to about 700 mV below GND by a diode-connected PNP transistor.

MAS9011 does not have any control pin. After the power supply is connected the device is ready to be used.

ABSOLUTE MAXIMUM RATINGS

All voltages with respect to ground.

Parameter	Symbol	Conditions	Min	Max	Unit
Supply Voltage	VDD		-0.3	6.0	V
Voltage range for all pins			-0.3	VDD+0.3	V
Operating temperature	T _A		-40	+85	°C
Storage Temperature	T _S		-50	+125	°C

ELECTRICAL CHARACTERISTICS

 T_A = -40°C to +85°C, typical values at T_A = +27°C, unless otherwise specified.

Parameter	Symbol	Conditions	Min	Typ	Max	Unit
Supply voltage	VDD		1.00		3.00	V
Current consumption	I _Q			100	300	nA
PO switching level	V _{PO}	Switching On Switching Off		1.15 1.10		V
PO hysteresis	V _{PO(H)}			50		mV
PO output voltage	V _{PO(OUT)}	VDD = 1.05 V, I _{PO} = -1.0 mA			0.06	V
LB switching level	V _{LB}	Switching On Switching Off		1.19 1.22		V
LB hysteresis	V _{LB(H)}			30		mV
LB output voltage	V _{LB(OUT)}	VDD = 1.15 V, I _{LB} = 50 μA VDD = 1.30 V, I _{LB} = -50 μA	0.95		0.20	V
SOL switching level	V _{SOL}	Switching On Switching Off		1.55 1.48		V
SOL hysteresis	V _{SOL(H)}			70		mV
SOL output current	I _{SOL}	VDD = 1.4 V, V _{SOL} = 0 V		TBD		nA
SOL leakage current		VDD = 1.7 V	-50		+50	nA
LB on level – PO off level				90		mV

TYPICAL APPLICATION

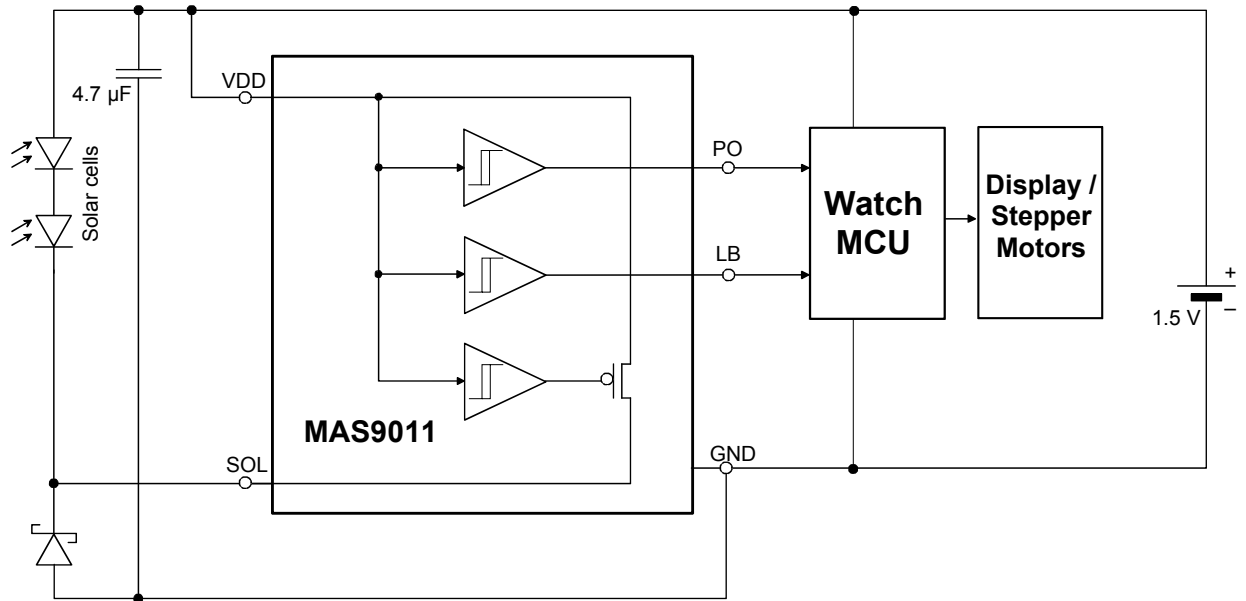
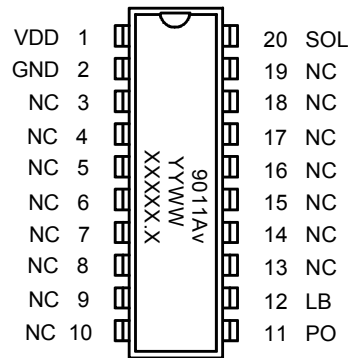

Figure 1. Typical application circuit of MAS9011

MAS9011 SAMPLES IN SBDIL 20 PACKAGE



SBDIL 20 PIN DESCRIPTION

Pin Name	Pin	Type	Function
VDD	1	P	Positive Power Supply
GND	2	G	Power Supply Ground
NC	3, 4, 5, 6, 7, 8, 9, 10		
PO	11	DO	Power On Output
LB	12	DO	Low Battery Output
NC	13, 14, 15, 16, 17, 18, 19		
SOL	20	AO	Full Battery Output

NC = Not Connected, P = Power, G = Ground, DO = Digital Output, AO = Analog Output

MAS9011 IN TSOT-5 PACKAGE

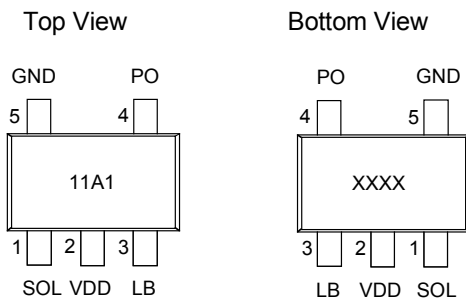

Bottom Marking Definitions:
 ZXXXX.Y = Lot Number
 (Example: Lot 12345.1 marking 2345)

TSOT-5 PIN DESCRIPTION

Pin Name	Pin	Type	Function
SOL	1	AO	Full Battery Output
VDD	2	P	Positive Power Supply
LB	3	DO	Low Battery Output
PO	4	DO	Power On Output
GND	5	G	Power Supply Ground

NC = Not Connected, P = Power, G = Ground, DO = Digital Output, AO = Analog Output

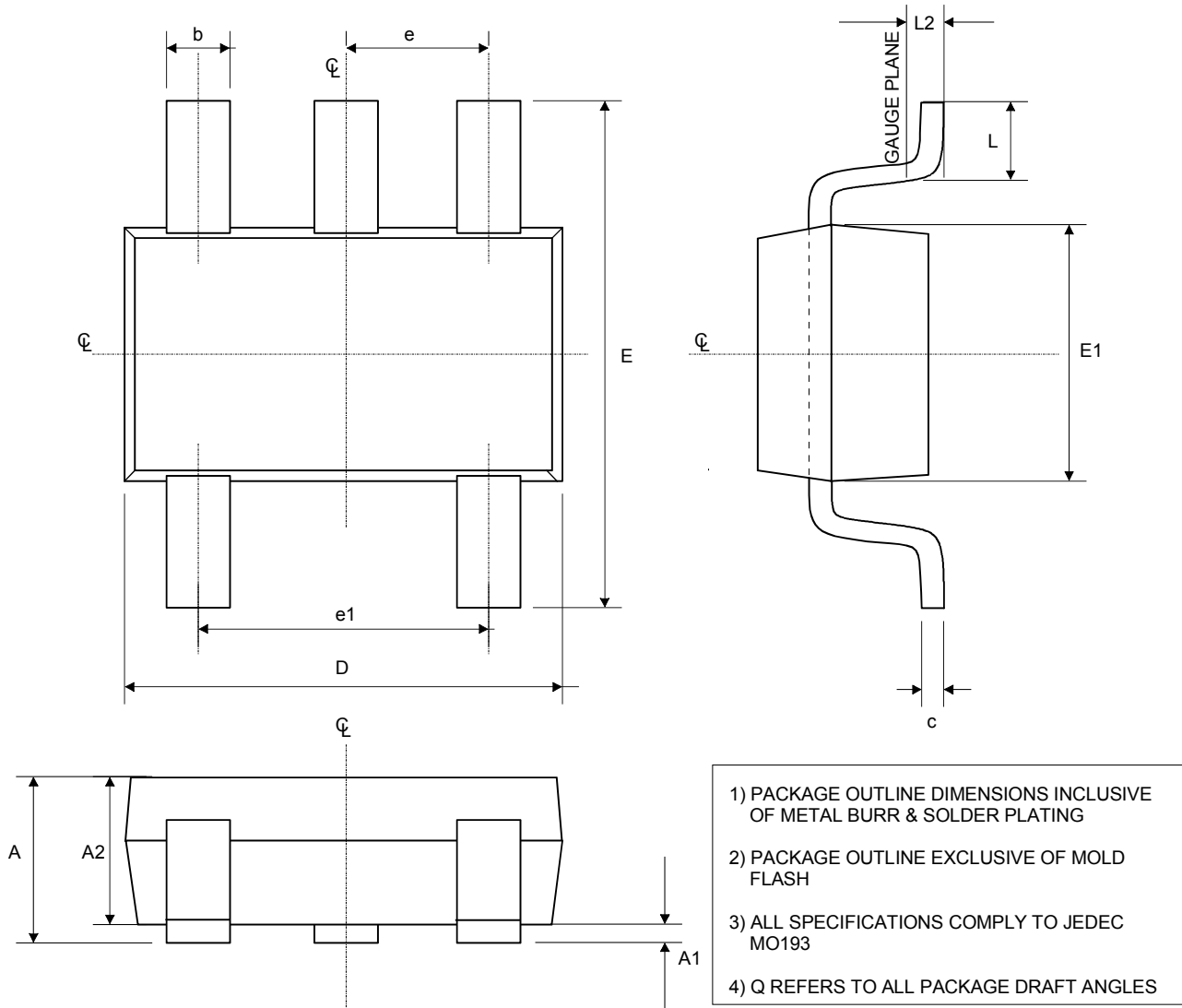
PACKAGE (TSOT-5) OUTLINE

Symbol	Min	Nom	Max	Unit
A	--	--	1.00	mm
A1	0.01	0.05	0.10	mm
A2	0.84	0.87	0.90	mm
b	0.30	--	0.45	mm
c	0.12	0.127	0.20	mm
D		2.90BSC		mm
E		2.80BSC		mm
E1		1.60BSC		mm
e		0.95BSC		mm
e1		1.90BSC		mm
L	0.30	0.40	0.50	mm
L2		0.25BSC		mm
Q	4°	10°	12°	

SOLDERING INFORMATION

◆ For Lead-Free TSOT-5

Resistance to Soldering Heat	According to RSH test IEC 68-2-58/20
Maximum Temperature	260°C
Maximum Number of Reflow Cycles	3
Reflow profile	Thermal profile parameters stated in JESD22-A113 should not be exceeded. http://www.jedec.org
Seating Plane Co-planarity	max 0.08 mm
Lead Finish	Solder plate 7.62 - 25.4 µm, material Matte Tin

TAPE & REEL SPECIFICATIONS (TSOT-5)

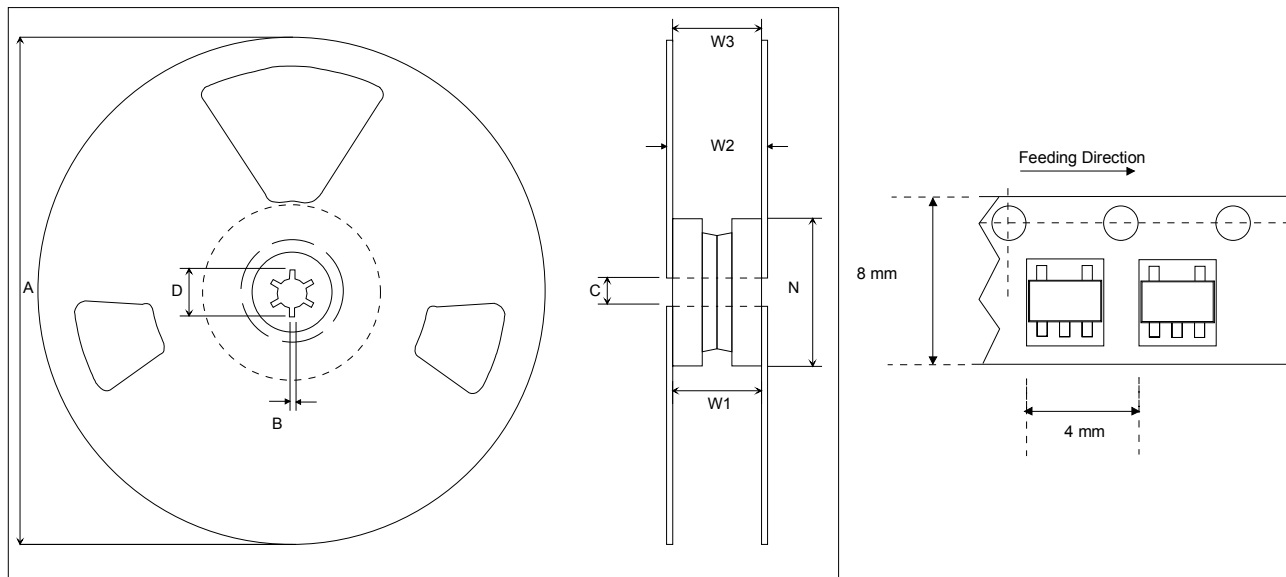

Other Dimensions according to EIA-481 Standard

3000 Components on Each Reel

Dimension	Min	Max	Unit
A		178	mm
B	1.5		mm
C	12.80	13.50	mm
D	20.2		mm
N	50		mm
W ₁ (measured at hub)	8.4	9.9	mm
W ₂ (measured at hub)		14.4	mm
W ₃ (includes flange distortion at outer edge)	7.9	10.9	mm
Trailer	160		mm
Leader	390, of which minimum 160 mm of empty carrier tape sealed with cover tape		mm

ORDERING INFORMATION

Product Code	Product	Package	Comments
MAS9011A1TC05	Solar Cell System Manager	Bare die, thickness 400 μm	Die Tray
MAS9011A1GB0 6	Solar Cell System Manager	TSOT-5 lead-free	Tape and Reel
MAS9011A1BD08	Solar Cell System Manager	SBDIL 20	Samples In Tube

LOCAL DISTRIBUTOR

--

MICRO ANALOG SYSTEMS OY CONTACTS

Micro Analog Systems Oy Kamreerintie 2, P.O. Box 51 FIN-02771 Espoo, FINLAND	Tel. +358 9 80 521 Fax +358 9 805 3213 http://www.mas-oy.com
--	--