

MN4073B / MN4073BS

Triple 3-Input AND Gates

■ Description

The MN4073B/S are positive 3-input AND gates and have 3 circuits in a package.

The outputs are fully buffered to improve the propagation characteristics between the input and output which are affected by increasing load capacitance and minimizes propagation delay time. Their primary use is where low power dissipation and/or high noise immunity is desired.

The MN4073B/S are equivalent to MOTOROLA MN14073B and RCA CD4073B.

■ Schematic Diagram (1/3)

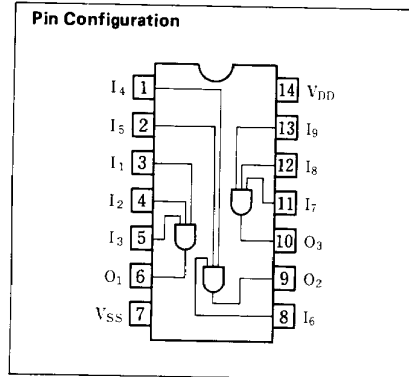
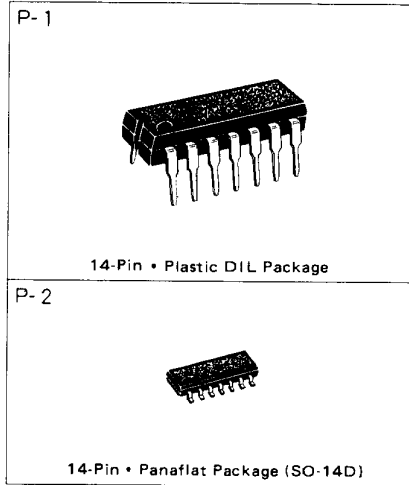
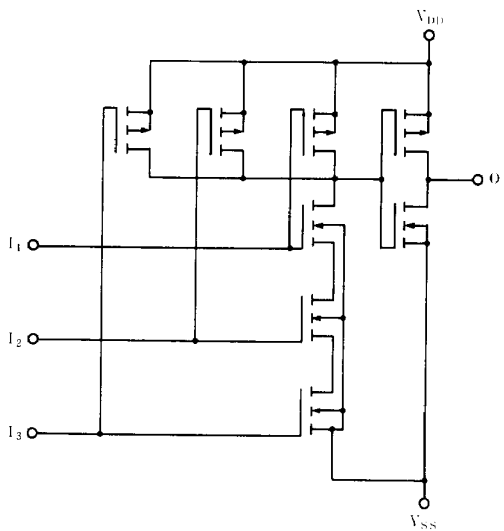

■ Maximum Ratings (Ta=25°C)

Item	Symbol	Ratings	Unit
Supply Voltage	V _{DD}	-0.5 ~ +18	V
Input Voltage	V _I	-0.5 ~ V _{DD} + 0.5*	V
Output Voltage	V _O	-0.5 ~ V _{DD} + 0.5*	V
Peak Input - Output Current	± I _I	max. 10	mA
Power Dissipation (per package)	P _D	max. 400	mW
		Decrease up to 200mW rating at 8mW/°C	
Power Dissipation (per output terminal)	P _D	max. 100	mW
Operating Ambient Temperature	T _{opr}	-40 ~ +85	°C
Storage Temperature	T _{stg}	-65 ~ +150	°C

* V_{DD} + 0.5V should be under 18V

■ DC Characteristics (V_{SS}=0V)

Item	V _{DD} (V)	Symbol	Conditions	Ta = -40°C		Ta = 25°C		Ta = 85°C		Unit
				min.	max.	min.	max.	min.	max.	
Quiescent Power Supply Current	5	I _{DD}	V _i =V _{SS} or V _{DD}	—	1	—	1	—	7.5	μA
	10			2	—	2	—	15		
	15			4	—	4	—	30		
Output Voltage Low Level	5	V _{OL}	V _i =V _{SS} or V _{DD} I _o < 1μA	—	0.05	—	0.05	—	0.05	V
	10			0.05	—	0.05	—	0.05		
	15			0.05	—	0.05	—	0.05		
Output Voltage High Level	5	V _{OH}	V _i =V _{SS} or V _{DD} I _o < 1μA	4.95	—	4.95	—	4.95	—	V
	10			9.95	—	9.95	—	9.95		
	15			14.95	—	14.95	—	14.95		
Input Voltage Low Level	5	V _{IL}	I _o < 1μA V _o =0.5V or 4.5V V _o =1V or 9V V _o =1.5V or 13.5V	—	1.5	—	1.5	—	1.5	V
	10			3	—	3	—	3		
	15			4	—	4	—	4		
Input Voltage High Level	5	V _{IH}	I _o < 1μA V _o =0.5V or 4.5V V _o =1V or 9V V _o =1.5V or 13.5V	3.5	—	3.5	—	3.5	—	V
	10			7	—	7	—	7		
	15			11	—	11	—	11		
Output Current Low Level	5	I _{OL}	V _o =0.4V, V _i =0 or 5V V _o =0.5V, V _i =0 or 10V V _o =1.5V, V _i =0 or 15V	0.52	—	0.44	—	0.36	—	mA
	10			1.3	—	1.1	—	0.9		
	15			3.6	—	3	—	2.4		
Output Current High Level	5	-I _{OH}	V _o =4.6V, V _i =0 or 5V V _o =9.5V, V _i =0 or 10V V _o =13.5V, V _i =0 or 15V	0.52	—	0.44	—	0.36	—	mA
	10			1.3	—	1.1	—	0.9		
	15			3.6	—	3	—	2.4		
Output Current High Level	5	-I _{OH}	V _o =2.5V, V _i =0 or 5V	1.7	—	1.4	—	1.1	—	mA
Input Leakage Current	15	±I _I	V _i =0 or 15V	—	0.3	—	0.3	—	1	μA

■ Switching Characteristics (Ta = 25°C, V_{SS} = 0V, C_i = 50pF)

Item	V _{DD} (V)	Symbol	min.	typ.	max.	Unit
Output Rise Time	5	t _{TLH}	—	60	180	ns
	10		30	90		
	15		20	60		
Output Fall Time	5	t _{THL}	—	60	180	ns
	10		30	90		
	15		20	60		
Propagation Delay Time	5	t _{PLH}	—	55	165	ns
	10		25	75		
	15		20	60		
Propagation Delay Time	5	t _{PHL}	—	45	135	ns
	10		20	60		
	15		15	45		
Input Capacitance		C _i	—	—	7.5	pF

1. Switching Time Test Circuit

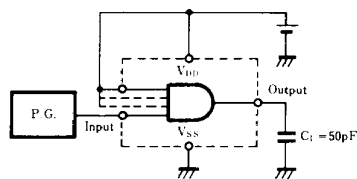

2. Waveforms

