

MN4071B / MN4071BS

Quad 2-Input OR Gates

■ Description

The MN4071B/S are positive 2-input OR gates and have 4 circuits in a package.

The outputs are fully buffered to improve the propagation characteristics between the input and output which are affected by increasing load capacitance and minimizes propagation delay time. Their primary use is where low power dissipation and/or high noise immunity is desired.

The MN4071B/S are equivalent to MOTOROLA MC14071B and RCA CD4071B.

■ Schematic Diagram (1/4)

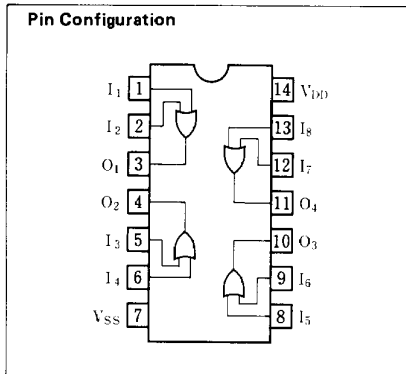
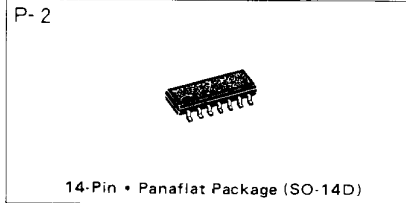
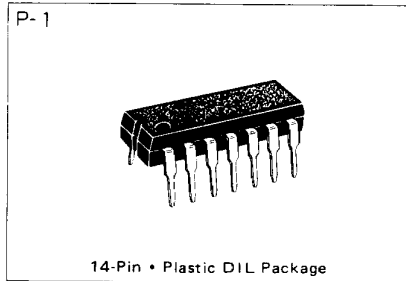
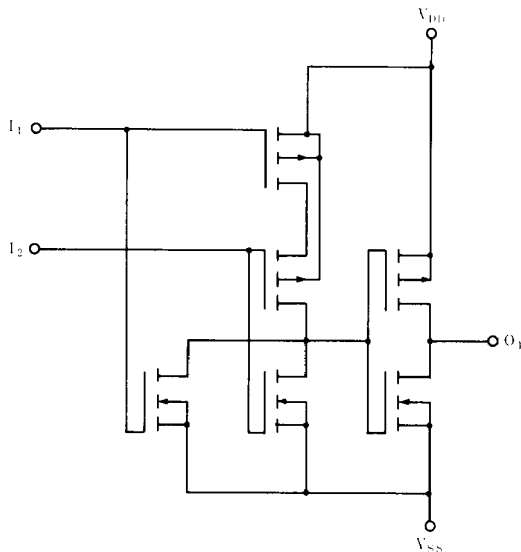

■ Maximum Ratings (Ta=25°C)

Item	Symbol	Ratings	Unit
Supply Voltage	V_{DD}	-0.5 ~ +18	V
Input Voltage	V_i	-0.5 ~ $V_{DD} + 0.5^*$	V
Output Voltage	V_o	-0.5 ~ $V_{DD} + 0.5^*$	V
Peak Input - Output Current	$\pm I_i$	max. 10	mA
Power Dissipation (per package)	P_D	Ta = -40 ~ +60°C	max. 400
		Ta = +60 ~ +85°C	Decrease up to 200mW rating at 8mW/°C
Power Dissipation (per output terminal)	P_{D1}	max. 100	mW
Operating Ambient Temperature	T_{opr}	-40 ~ +85	°C
Storage Temperature	T_{stg}	-65 ~ +150	°C

* $V_{DD} + 0.5V$ should be under 18V

■ DC Characteristics ($V_{SS}=0V$)

Item	V_{DD} (V)	Sym- bol	Conditions	$T_a=-40^{\circ}C$		$T_a=25^{\circ}C$		$T_a=85^{\circ}C$		Unit
				min.	max.	min.	max.	min.	max.	
Quiescent Power Supply Current	5	I_{DD}	$V_i=V_{SS}$ or V_{DD}	—	1	—	1	—	7.5	μA
	10			—	2	—	2	—	15	
	15			—	4	—	4	—	30	
Output Voltage Low Level	5	V_{OL}	$V_i=V_{SS}$ or V_{DD} $ I_o < 1\mu A$	—	0.05	—	0.05	—	0.05	V
	10			—	0.05	—	0.05	—	0.05	
	15			—	0.05	—	0.05	—	0.05	
Output Voltage High Level	5	V_{OH}	$V_i=V_{SS}$ or V_{DD} $ I_o < 1\mu A$	4.95	—	4.95	—	4.95	—	V
	10			9.95	—	9.95	—	9.95	—	
	15			14.95	—	14.95	—	14.95	—	
Input Voltage Low Level	5	V_{IL}	$ I_o < 1\mu A$	$V_o=0.5V$ or $4.5V$	—	1.5	—	1.5	—	V
	10			$V_o=1V$ or $9V$	—	3	—	3	—	
	15			$V_o=1.5V$ or $13.5V$	—	4	—	4	—	
Input Voltage High Level	5	V_{IH}	$ I_o < 1\mu A$	$V_o=0.5V$ or $4.5V$	3.5	—	3.5	—	3.5	V
	10			$V_o=1V$ or $9V$	7	—	7	—	7	
	15			$V_o=1.5V$ or $13.5V$	11	—	11	—	11	
Output Current Low Level	5	I_{OL}	$V_o=0.4V, V_i=0$ or $5V$	0.52	—	0.44	—	0.36	—	mA
	10		$V_o=0.5V, V_i=0$ or $10V$	1.3	—	1.1	—	0.9	—	
	15		$V_o=1.5V, V_i=0$ or $15V$	3.6	—	3	—	2.4	—	
Output Current High Level	5	$-I_{OH}$	$V_o=4.6V, V_i=0$ or $5V$	0.52	—	0.44	—	0.36	—	mA
	10		$V_o=9.5V, V_i=0$ or $10V$	1.3	—	1.1	—	0.9	—	
	15		$V_o=13.5V, V_i=0$ or $15V$	3.6	—	3	—	2.4	—	
Output Current High Level	5	$-I_{OH}$	$V_o=2.5V, V_i=0$ or $5V$	1.7	—	1.4	—	1.1	—	mA
Input Leakage Current	15	$\pm I_i$	$V_i=0$ or $15V$	—	0.3	—	0.3	—	1	μA

■ Switching Characteristics ($T_a=25^{\circ}C, V_{SS}=0V, C_L=50pF$)

Item	V_{DD} (V)	Symbol	min.	typ.	max.	Unit
Output Rise Time	5	t_{TLH}	—	60	180	ns
	10		—	30	90	
	15		—	20	60	
Output Fall Time	5	t_{THL}	—	60	180	ns
	10		—	30	90	
	15		—	20	60	
Propagation Delay Time	5	t_{PLH}	—	55	165	ns
	10		—	25	75	
	15		—	20	60	
Propagation Delay Time	5	t_{PHL}	—	45	135	ns
	10		—	20	60	
	15		—	15	45	
Input Capacitance		C_i	—	—	7.5	pF

1. Switching Time Test Circuit

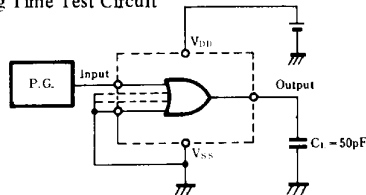

2. Waveforms

