

### FEATURES

- **SMALL PACKAGE STYLE:**  
2 NE688 Die in a 2 mm x 1.25 mm package
- **LOW NOISE FIGURE:**  
NF = 1.5 dB TYP at 2 GHz
- **HIGH GAIN BANDWIDTH:**  $f_T = 9$  GHz
- **HIGH COLLECTOR CURRENT:** 100 mA

### DESCRIPTION

The UPA809T is two NPN high frequency silicon epitaxial transistors encapsulated in an ultra small 6 pin SMT package. Each transistor is independently mounted and easily configured for either dual transistor or cascode operation. The high  $f_T$ , low voltage bias and small size make this device suited for various hand-held wireless applications.

### ABSOLUTE MAXIMUM RATINGS<sup>1</sup> ( $T_A = 25^\circ\text{C}$ )

SYMBOLS	PARAMETERS	UNITS	RATINGS
V <sub>CB0</sub>	Collector to Base Voltage	V	9
V <sub>CEO</sub>	Collector to Emitter Voltage	V	6
V <sub>EB0</sub>	Emitter to Base Voltage	V	2
I <sub>c</sub>	Collector Current	mA	100
PT	Total Power Dissipation		
	1 Die	mW	110
	2 Die	mW	200
T <sub>J</sub>	Junction Temperature	°C	150
T <sub>STG</sub>	Storage Temperature	°C	-65 to +150

Note:

1. Operation in excess of any one of these parameters may result in permanent damage.

### ELECTRICAL CHARACTERISTICS ( $T_A = 25^\circ\text{C}$ )

PART NUMBER PACKAGE OUTLINE			UPA809T S06		
SYMBOLS	PARAMETERS AND CONDITIONS	UNITS	MIN	TYP	MAX
I <sub>CBO</sub>	Collector Cutoff Current at V <sub>CB</sub> = 5V, I <sub>E</sub> = 0	μA			0.1
I <sub>EBO</sub>	Emitter Cutoff Current at V <sub>EB</sub> = 1 V, I <sub>C</sub> = 0	μA			0.1
h <sub>FE</sub> <sup>1</sup>	Forward Current Gain at V <sub>CE</sub> = 1 V, I <sub>C</sub> = 3 mA		80	110	160
f <sub>T</sub>	Gain Bandwidth at V <sub>CE</sub> = 3 V, I <sub>C</sub> = 20 mA, f = 2 GHz	GHz		9.0	
C <sub>re</sub> <sup>2</sup>	Feedback Capacitance at V <sub>CB</sub> = 1 V, I <sub>E</sub> = 0, f = 1 MHz	pF		0.75	0.85
S <sub>21E</sub>   <sup>2</sup>	Insertion Power Gain at V <sub>CE</sub> = 3 V, I <sub>C</sub> = 20 mA, f = 2 GHz	dB		6.5	
NF	Noise Figure at V <sub>CE</sub> = 3 V, I <sub>C</sub> = 7 mA, f = 2 GHz	dB		1.5	
h <sub>FE1</sub> /h <sub>FE2</sub>	h <sub>FE</sub> Ratio: h <sub>FE1</sub> = Smaller Value of Q <sub>1</sub> , or Q <sub>2</sub> h <sub>FE2</sub> = Larger Value of Q <sub>1</sub> or Q <sub>2</sub>		0.85		

Notes: 1. Pulsed measurement, pulse width ≤ 350 μs, duty cycle ≤ 2 %.

2. The emitter terminal should be connected to the ground terminal of the 3 terminal capacitance bridge.

For Tape and Reel version use part number UPA809T-T1, 3K per reel.

### OUTLINE DIMENSIONS (Units in mm)

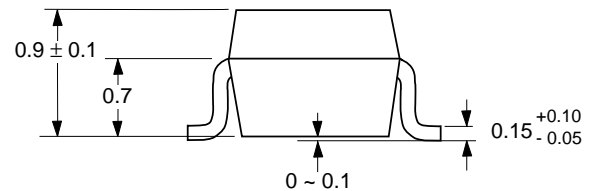
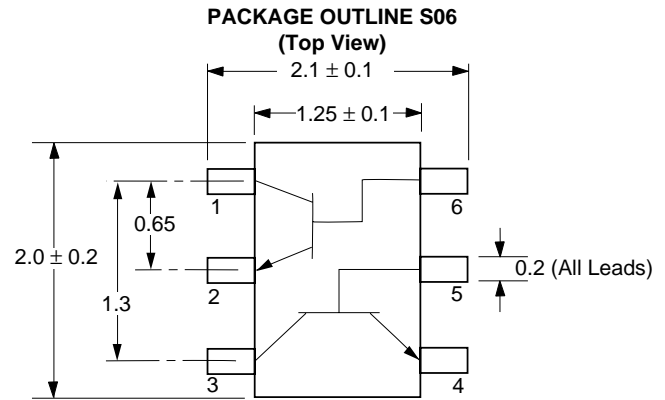

#### PIN OUT

1. Collector Transistor 1
2. Emitter Transistor 1
3. Collector Transistor 2
4. Emitter Transistor 2
5. Base Transistor 2
6. Base Transistor 1

Note:

Pin 3 is identified with a circle on the bottom of the package.

TYPICAL PERFORMANCE CURVES (T<sub>A</sub> = 25°C)

TOTAL POWER DISSIPATION vs. AMBIENT TEMPERATURE

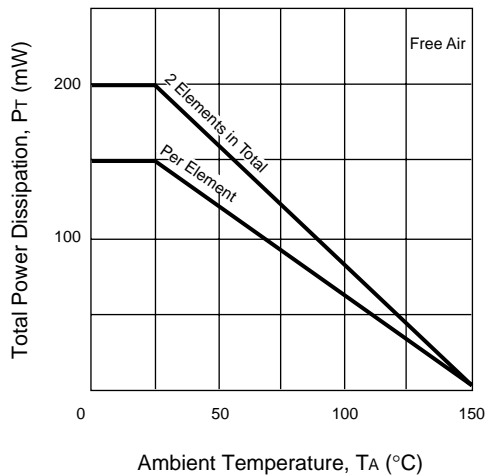

COLLECTOR CURRENT vs. BASE TO EMITTER VOLTAGE

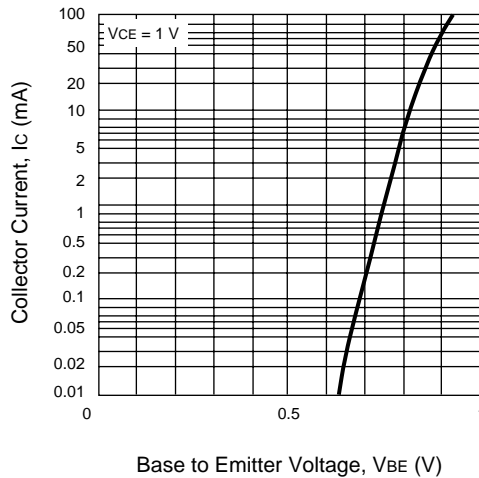

COLLECTOR CURRENT vs. COLLECTOR TO EMITTER VOLTAGE

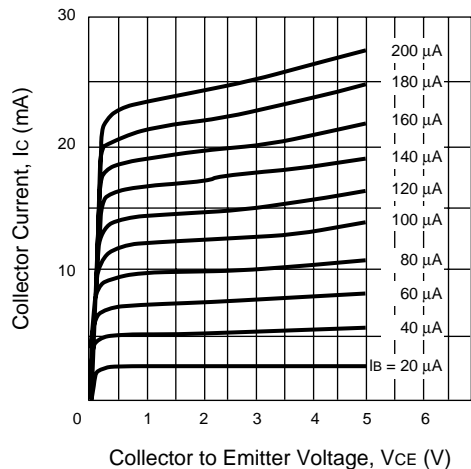

DC CURRENT GAIN vs. COLLECTOR CURRENT

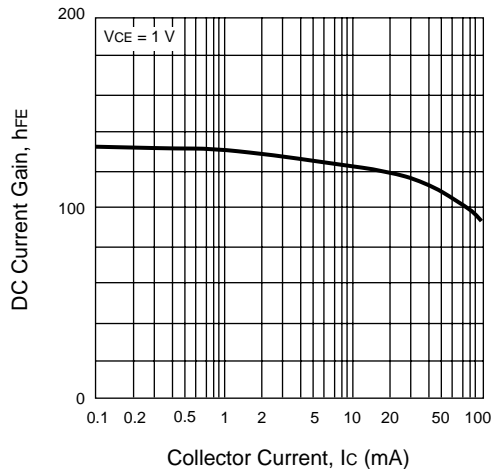

GAIN BANDWIDTH PRODUCT vs. COLLECTOR CURRENT

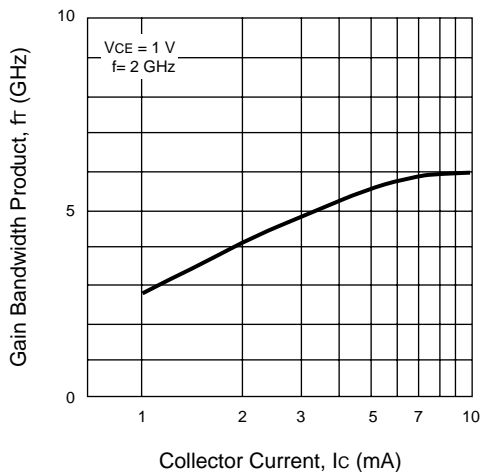

INSERTION POWER GAIN vs. COLLECTOR CURRENT

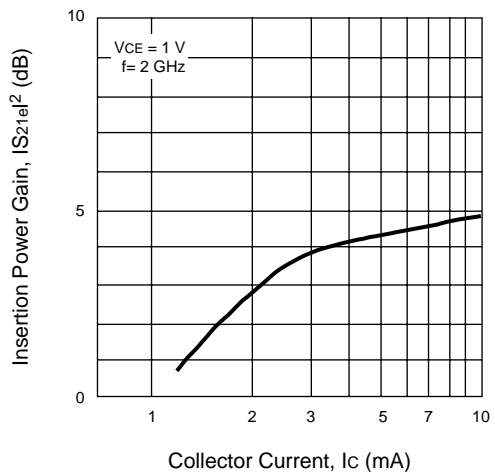

**TYPICAL PERFORMANCE CURVES** ( $T_A = 25^\circ\text{C}$ )

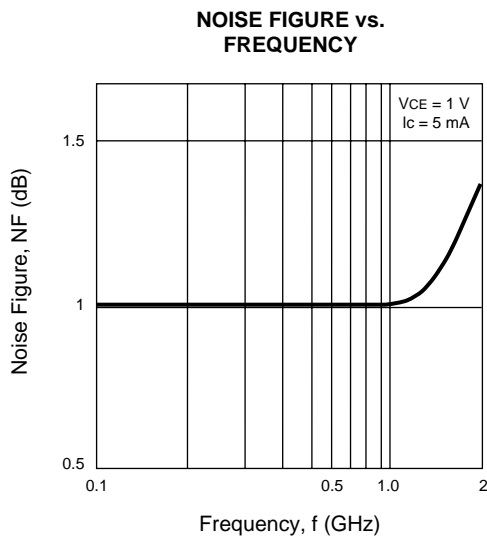
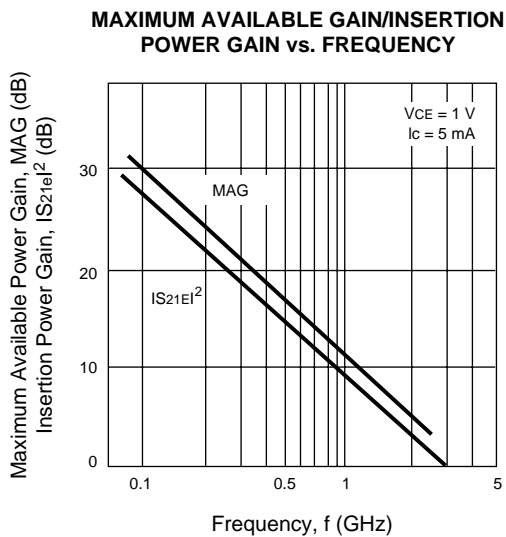
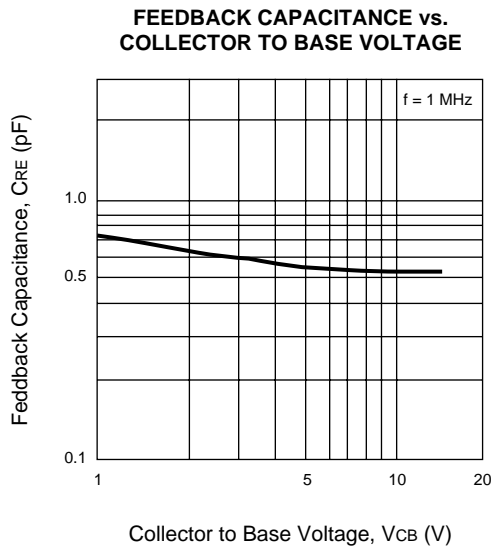
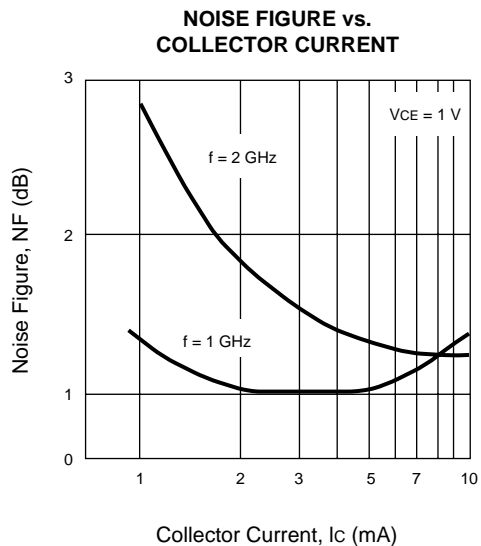

**ORDERING INFORMATION**

PART NUMBER	QUANTITY	PACKAGING
UPA809T-T1	3000	Tape & Reel

## BJT NONLINEAR MODEL PARAMETERS (1)

Parameters	Q1, Q2	Parameters	Q1, Q2
IS	3.8e-16	MJC	0.48
BF	135.7	XCJC	0.56
NF	1	CJS	0
VAF	28	VJS	0.75
IKF	0.6	MJS	0
ISE	3.8e-15	FC	0.75
NE	1.49	TF	9e-12
BR	12.3	XTF	0.36
NR	1.1	VTF	0.65
VAR	3.5	ITF	0.61
IKR	0.06	PTF	50
ISC	3.5e-16	TR	32e-12
NC	1.62	EG	1.11
RE	0.4	XTB	0
RB	6.14	XTI	3
RBM	3.5	KF	0
IRB	0.001	AF	1
RC	4.2		
CJE	0.796e-12		
VJE	0.71		
MJE	0.38		
CJC	0.45e-12		
VJC	0.65		

(1) Gummel-Poon Model

## Note:

This nonlinear model utilized the latest data available.  
See our Design Parameter Library at [www.cel.com](http://www.cel.com) for this data.

## UNITS

Parameter	Units
time	seconds
capacitance	farads
inductance	henries
resistance	ohms
voltage	volts
current	amps

## MODEL RANGE

Frequency: 0.1 to 3.0 GHz  
Bias:  $V_{CE} = 1\text{ V to }5\text{ V}$ ,  $I_c = 1\text{ mA to }10\text{ mA}$   
Date: 11/98

## NONLINEAR MODEL

## SCHEMATIC

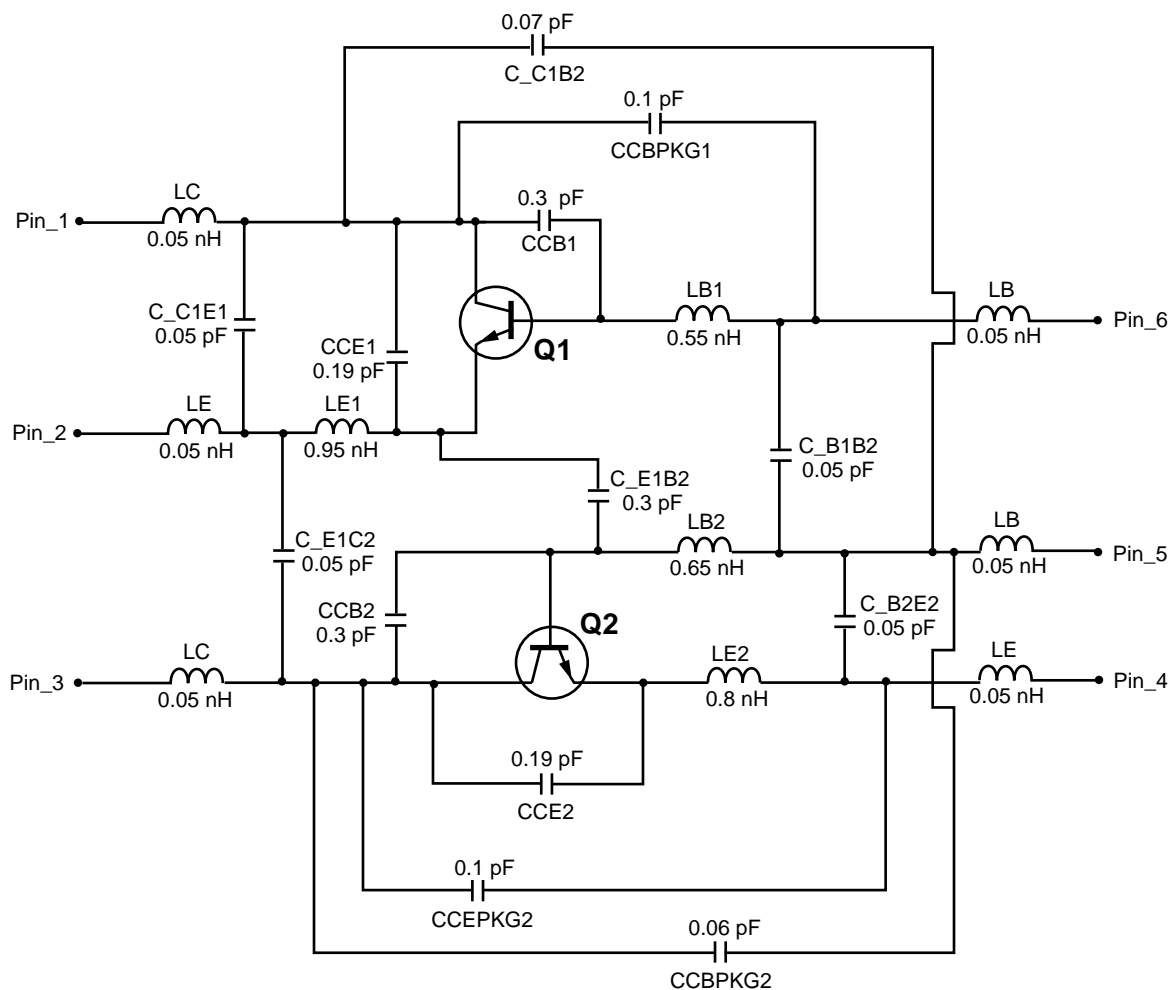

## MODEL RANGE

Frequency: 0.1 to 3.0 GHz  
 Bias:  $V_{CE} = 1 \text{ V to } 5 \text{ V}$ ,  $I_c = 1 \text{ mA to } 10 \text{ mA}$   
 Date: 11/98

EXCLUSIVE NORTH AMERICAN AGENT FOR **NEC** RF, MICROWAVE & OPTOELECTRONIC SEMICONDUCTORS

**CEL** CALIFORNIA EASTERN LABORATORIES ¥ Headquarters ¥ 4590 Patrick Henry Drive ¥ Santa Clara, CA 95054-1817 ¥ (408) 988-3500 ¥ Telex 34-6393 ¥ FAX (408) 988-02  
 24-Hour Fax-On-Demand: 800-390-3232 (U.S. and Canada only) ¥ Internet: <http://WWW.CEL.COM>

DATA SUBJECT TO CHANGE WITHOUT NOTICE

8/99