

**FEATURES AND BENEFITS**

- Over 500,000 duty cycles with 10 year life capability
- Hermetically sealed, stainless steel construction
- Low profile prismatic design
- Higher energy vs electrolytic capacitors
- Higher power vs batteries

**TYPICAL APPLICATIONS**

- Automotive subsystems
- Smart meter
- Back up power for SSD and NV-DIMM
- Consumer electronics
- Wireless transmissions
- NASA space qualified

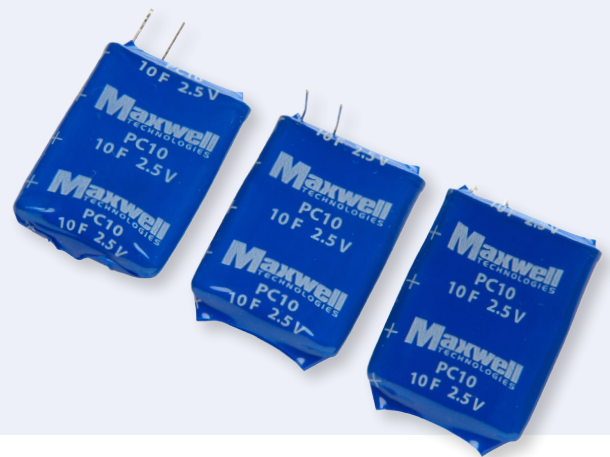

**PRODUCT SPECIFICATIONS**

ELECTRICAL	PC10, PC10-90, PC10-270	PC10HT, PC10HT-90, PC10HT-270
Rated Capacitance <sup>1</sup>	10 F	10 F
Minimum Capacitance, initial <sup>1</sup>	9 F	9 F
Maximum ESR <sub>DC</sub> , initial <sup>1</sup>	180 mΩ	180 mΩ
Rated Voltage	2.50 V	2.20 V
Absolute Maximum Voltage <sup>11</sup>	2.70 V	2.70 V
Maximum Continuous Current (ΔT = 15°C) <sup>2</sup>	2.4 A <sub>RMS</sub>	2.4 A <sub>RMS</sub>
Maximum Continuous Current (ΔT = 40°C) <sup>2</sup>	3.8 A <sub>RMS</sub>	3.8 A <sub>RMS</sub>
Maximum Peak Current, 1 second (non repetitive) <sup>3</sup>	4.5 A	3.9 A
Leakage Current, maximum <sup>4</sup>	0.040 mA	0.040 mA
TEMPERATURE		
Operating temperature range (Cell case temperature)		
Minimum	-40°C	-40°C
Maximum	70°C	85°C
Storage temperature range (Stored uncharged)		
Minimum	-40°C	-40°C
Maximum	85°C	85°C
PHYSICAL		
Mass, typical	6.3 g	6.3 g
Terminals	Wire Leads	Wire Leads
Vibration	ISO16750-3, Table 14	ISO16750-3, Table 14
Shock	-	-

## PRODUCT SPECIFICATIONS (Cont'd)

POWER & ENERGY	PC10, PC10-90, PC10-270	PC10HT, PC10HT-90, PC10HT-270
Usable Specific Power, $P_d^5$	660 W/kg	510 W/kg
Impedance Match Specific Power, $P_{max}^6$	1,400 W/kg	1,100 W/kg
Specific Energy, $E_{max}^7$	1.4 Wh/kg	1.1 Wh/kg
Stored Energy <sup>8</sup>	0.009 Wh	0.007 Wh
LIFE		
High Temperature <sup>1</sup> (at Rated Voltage & Maximum Operating Temperature)	3,000 hours	1,000 hours
Capacitance Change (% decrease from minimum initial value)	20%	20%
ESR Change (% increase from maximum initial value)	100%	100%
Room Temperature <sup>1</sup> (at Rated Voltage & 25°C)	10 years	10 years
Capacitance Change (% decrease from minimum initial value)	20%	20%
ESR Change (% increase from maximum initial value)	100%	100%
Cycle Life <sup>1,9</sup>	500,000 cycles	500,000 cycles
Capacitance Change (% decrease from minimum initial value)	20%	20%
ESR Change (% increase from maximum initial value)	100%	100%
Test Current	1.0 A	1.0 A
Shelf Life <sup>1,10</sup> (Stored uncharged up to a maximum storage temperature)	2 years	2 years
SAFETY		
Short Circuit Current, typical (Current possible with short circuit from rated voltage. Do not use as an operating current.)	14 A	12 A
Certifications	UL810a, RoHS	UL810a, RoHS

## TYPICAL CHARACTERISTICS

### THERMAL CHARACTERISTICS

PC10, PC10-90, PC10-270

PC10HT, PC10HT-90, PC10HT-270

Thermal Resistance  
(R<sub>th</sub>, Case to Ambient), typical<sup>2</sup>

15°C/W

15°C/W

Thermal Capacitance (C<sub>th</sub>), typical<sup>2</sup>

3.6 J/°C

3.6 J/°C

PC-10 HT Temperature Response Plot

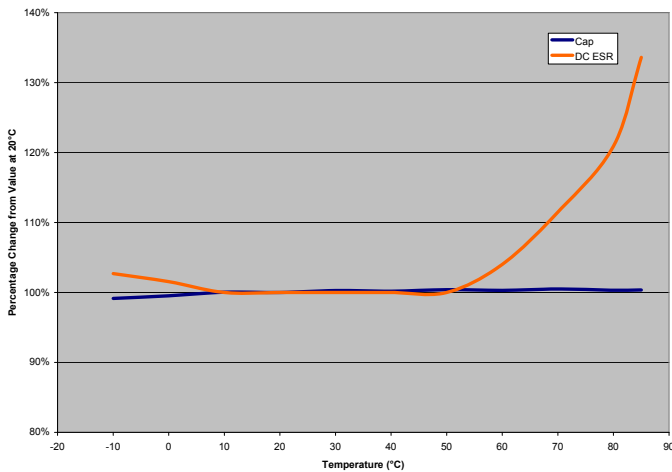

## NOTES

1. Capacitance and ESR<sub>DC</sub> measured at 25°C per Document Number 1007239 available at [www.maxwell.com](http://www.maxwell.com).

2. Per Maxwell Document 1007239 available at [www.maxwell.com](http://www.maxwell.com).

3. Maximum Peak current (1 sec) =  $\frac{1/2 CV}{C \times ESR_{DC} + 1}$

4. After 72 hours at 25°C and rated voltage. Initial leakage current can be higher.

5. Per IEC 62391-2,  $P_d = \frac{0.12V^2}{ESR_{DC} \times \text{mass}}$

$$6. P_{max} = \frac{V^2}{4 \times ESR_{DC} \times \text{mass}}$$

$$7. E_{max} = \frac{1/2 CV^2}{3,600 \times \text{mass}}$$

$$8. E_{stored} = \frac{1/2 CV^2}{3,600}$$

9. Cycle per Document Number 1007239 available at [www.maxwell.com](http://www.maxwell.com).

10. No more than 10% decrease in capacitance from minimum initial capacitance or 50% increase in ESR from maximum initial ESR.

11. Absolute maximum voltage non repeated, not to exceed 1 second.

## MOUNTING RECOMMENDATIONS

Do not reverse polarity. Please refer to document number 1008238, available at [maxwell.com](http://maxwell.com) for soldering recommendations.

## MARKINGS

Products are marked with the following information: Rated capacitance, rated voltage, product number, name of manufacturer, and positive terminal.

## PC10, PC10HT

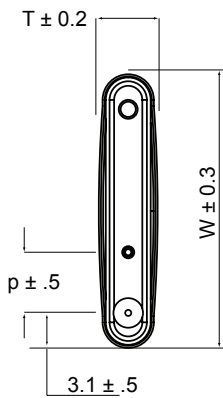
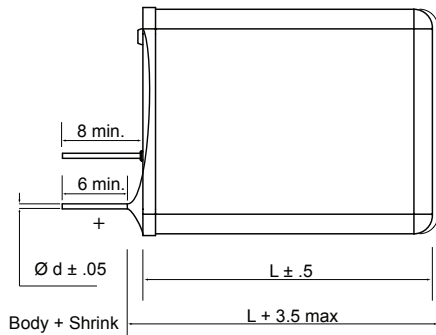

## PC10-90, PC10HT-90

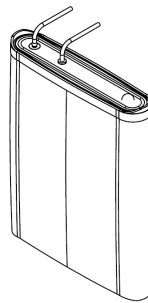
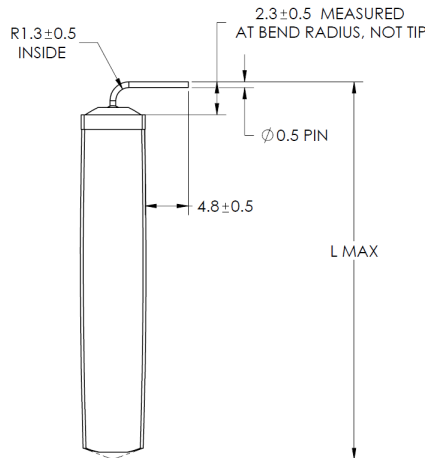

## PC10-270, PC10HT-270

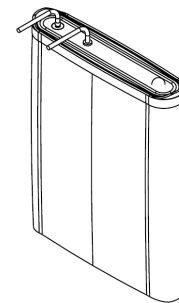
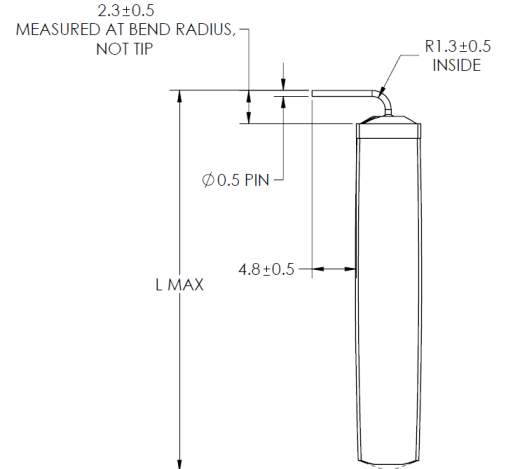

Part Description	Dimensions (mm)					Package Quantity
	L (mm)	W (mm)	T (mm)	d (mm)	p (mm)	
PC10, PC10HT	29.6	23.6	4.8	0.5	5.1	2,000
PC10-90, PC10HT-90	35.9	23.6	4.8	0.5	5.1	2,000
PC10-270, PC10HT-270	35.9	23.6	4.8	0.5	5.1	2,000

Product dimensions are for reference only unless otherwise identified. Product dimensions and specifications may change without notice. Please contact Maxwell Technologies directly for any technical specifications critical to application. All products featured on this datasheet are covered by the following U.S. patents and their respective foreign counterparts: 6.842.330, 7.116.545, 7.352.558, 7.295.423, 7.090.946, 7.508.651, 7.492.571, 7.342.770, 6.643.119, 7.384.433, 7.147.674, 7.317.609, 7.495.349, 7.102.877.



**Maxwell Technologies, Inc.**  
**Global Headquarters**  
 5271 Viewridge Court, Suite 100  
 San Diego, CA 92123  
 USA  
 Tel: +1 858 503 3300  
 Fax: +1 858 503 3301



**Maxwell Technologies SA**  
 CH-1728 Rossens  
 Switzerland  
 Tel: +41 (0)26 411 85 00  
 Fax: +41 (0)26 411 85 05



**Maxwell Technologies, GmbH**  
 Brucker Strasse 21  
 D-82205 Gilching  
 Germany  
 Tel: +49 (0)8105 24 16 16  
 Fax: +49 (0)8105 24 16 19



**Maxwell Technologies, Inc.**  
**Shanghai Representative Office**  
 13E, CR Times Square  
 500 Zhangyang Road, Pudong  
 Shanghai 200122, P.R. China  
 Tel: +86 21 5836 8780  
 Fax: +86 21 5836 8790