

## Power Integrated Module (PIM)

### ■ Features

- NPT-Technology
- Solderable Package
- Square SC SOA at  $10 \times I_C$
- High Short Circuit Withstand-Capability
- Small Temperature Dependence of the Turn-Off Switching Loss
- Low Losses And Soft Switching

### ■ Equivalent Circuit

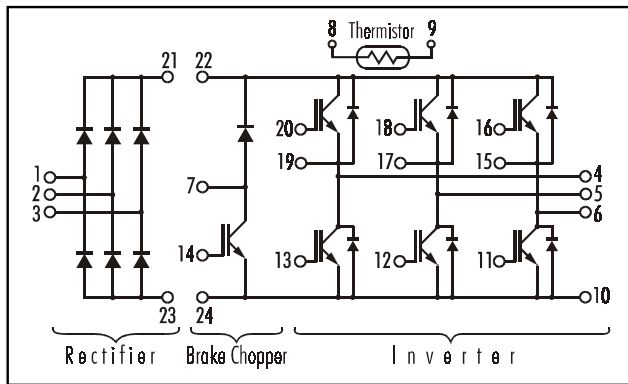

### ■ Outline Drawing

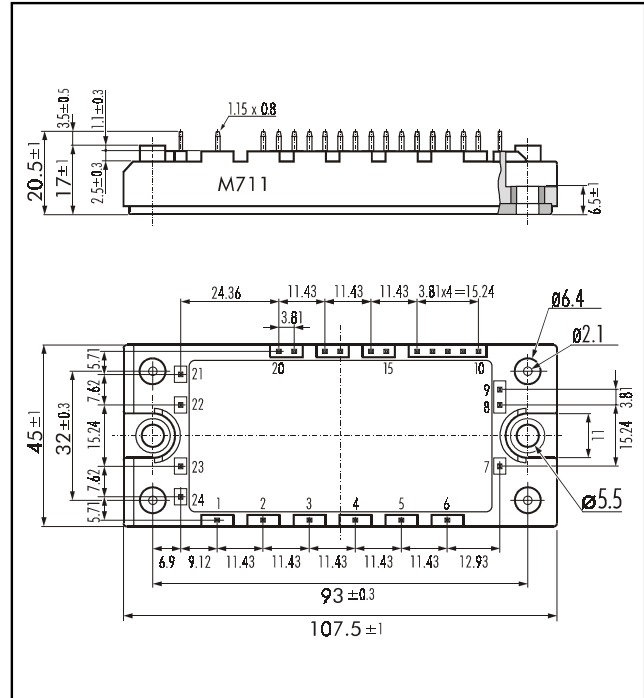

### ■ Absolute Maximum Ratings ( $T_c=25^\circ\text{C}$ )

	Items	Symbols	Test Conditions	Ratings	Units	
Inverter	Collector-Emitter Voltage	$V_{CES}$		1200	V	
	Gate -Emitter Voltage	$V_{GES}$		$\pm 20$		
	Collector Current	$I_C$		Continuous	$25^\circ\text{C} / 80^\circ\text{C}$	15 / 10
		$I_{C\text{ PULSE}}$		1ms	$25^\circ\text{C} / 80^\circ\text{C}$	30 / 20
		$-I_{C\text{ PULSE}}$				10
Collector Power Dissipation	$P_C$		1 device	75	W	
Rectifier	Repetitive Peak Reverse Voltage	$V_{RRM}$		1600	V	
	Average Output Current	$I_O$	50Hz/60Hz sinus wave	10	A	
	Surge Current (Non Repetitive)	$I_{FSM}$	$T_j=150^\circ\text{C}$ , 10 ms, sinus wave	105		
	$I^2t$ (Non Repetitive)			55	$\text{A}^2\text{s}$	
Brake Chopper	Collector-Emitter Voltage	$V_{CES}$		1200	V	
	Gate -Emitter Voltage	$V_{GES}$		$\pm 20$		
	Collector Current	$I_C$		Continuous	$25^\circ\text{C} / 80^\circ\text{C}$	15 / 10
		$I_{C\text{ PULSE}}$		1ms	$25^\circ\text{C} / 80^\circ\text{C}$	30 / 20
	Collector Power Dissipation	$P_C$		1 device	75	W
Repetitive Peak Reverse Voltage	$V_{RRM}$			1200	V	
	Operating Junction Temperature	$T_j$		+150	$^\circ\text{C}$	
	Storage Temperature	$T_{Stg}$		-40 ~ +125		
	Isolation Voltage	$V_{ISO}$	A.C. 1min.	2500	V	
	Mounting Screw Torque*			3.5	Nm	

Note: \*:Recommendable Value; 2.5 ~ 3.5 Nm (M5)

## ■ Electrical Characteristics (T<sub>J</sub>=25°C)

Items		Symbols	Test Conditions	Min.	Typ.	Max.	Units	
Inverter	IGBT	Zero Gate Voltage Collector Current	I <sub>CES</sub>	V <sub>GE</sub> =0V V <sub>CE</sub> =1200V			1.0	mA
		Gate-Emitter Leakage Current	I <sub>GES</sub>	V <sub>CE</sub> =0V V <sub>GE</sub> =± 20V			200	nA
		Gate-Emitter Threshold Voltage	V <sub>GE(th)</sub>	V <sub>GE</sub> =20V I <sub>C</sub> =10mA	5.5	7.2	8.5	
		Collector-Emitter Saturation Voltage	V <sub>CE(sat)</sub>	V <sub>GE</sub> =15V I <sub>C</sub> = 10A	Chip	2.1		V
		Input Capacitance	C <sub>ies</sub>	f=1MHz, V <sub>GE</sub> =0V, V <sub>CE</sub> =10V		1200		pF
	Turn-on Time	t <sub>on</sub>	V <sub>CC</sub> = 600V I <sub>C</sub> = 10A		0.35	1.2		
		t <sub>r,x</sub>	V <sub>GE</sub> = ±15V		0.25	0.6		
		t <sub>r,i</sub>	R <sub>G</sub> = 120Ω		0.45	1.0		
		Turn-off Time	t <sub>off</sub>		Inductive Load	0.08	0.3	
			t <sub>f</sub>					
FRD	Diode Forward On-Voltage	V <sub>F</sub>	I <sub>F</sub> =10A	Chip	2.3		V	
	Reverse Recovery Time	t <sub>rr</sub>	I <sub>F</sub> =10A	Terminal	2.35	3.2	ns	
Rectifier	Forward Voltage	V <sub>FM</sub>	I <sub>F</sub> =10A	Chip	1.1		V	
	Reverse Current	I <sub>RRM</sub>	V <sub>R</sub> =1600V	Terminal	1.2	1.5	mA	
Brake Chopper	Zero Gate Voltage Collector Current	I <sub>CES</sub>	V <sub>GE</sub> =0V V <sub>CE</sub> =1200V			1.0	mA	
	Gate-Emitter Leakage Current	I <sub>GES</sub>	V <sub>CE</sub> =0V V <sub>GE</sub> =± 20V			200	nA	
	Collector-Emitter Saturation Voltage	V <sub>CE(sat)</sub>	V <sub>GE</sub> =10V I <sub>C</sub> =10A	Chip	2.10		V	
				Terminal	2.20	2.6		
	Turn-on Time	t <sub>on</sub>	V <sub>CC</sub> = 600V I <sub>C</sub> = 10A		0.35	1.2		
		t <sub>r,x</sub>	V <sub>GE</sub> = ±15V		0.25	0.6		
	Turn-off Time	t <sub>off</sub>	R <sub>G</sub> = 120Ω		0.45	1.0		
t <sub>f</sub>				0.08	0.3			
Reverse Current	I <sub>RRM</sub>	V <sub>R</sub> =1200V			1.0	mA		
NTC	Resistance	R	T= 25°C		5000		Ω	
	B Value	B	T=100°C	465	495	520		
			T=25 / 50°C	3305	3375	3450	K	

## ■ Thermal Characteristics

Items	Symbols	Test Conditions	Min.	Typ.	Max.	Units
Thermal Resistance (1 device)	R <sub>th(j-c)</sub>	Inverter IGBT			1.67	°C/W
		Inverter FRD			2.78	
		Brake IGBT			1.67	
		Rectifier Diode			1.85	
Contact Thermal Resistance	R <sub>th(c-f)</sub>	With Thermal Compound		0.05		

