

# AN6884

## 5-Dot LED Driver Circuit

### ■ Description

The AN6884 is a monolithic integrated circuit driving 5-LED and is capable of logarithmic (dB) bar graph display for input signal. Incorporating high gain rectification amp. enable to apply AC (UV meter, etc.) / DC (signal meter, etc.) level meter widely.

### ■ Features

- Wide range of operating voltage:  
 $V_{CC(opr.)} = 3.5V \sim 16V$
- Constant current output:  $I_{LED} = 15mA$
- Built-in high gain amp.:  $G_V = 26dB$  typ.
- Low noise when LED ON
- 5-dot LED bar logarithmic response: -10, -5, 0, 3, 6dB
- Fewer external components

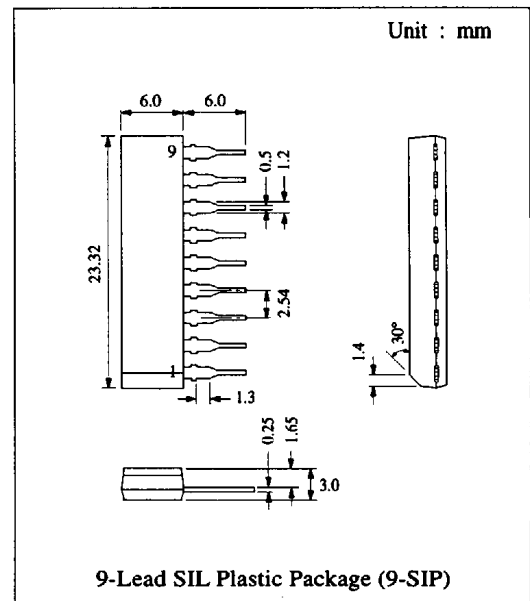

### ■ Block Diagram

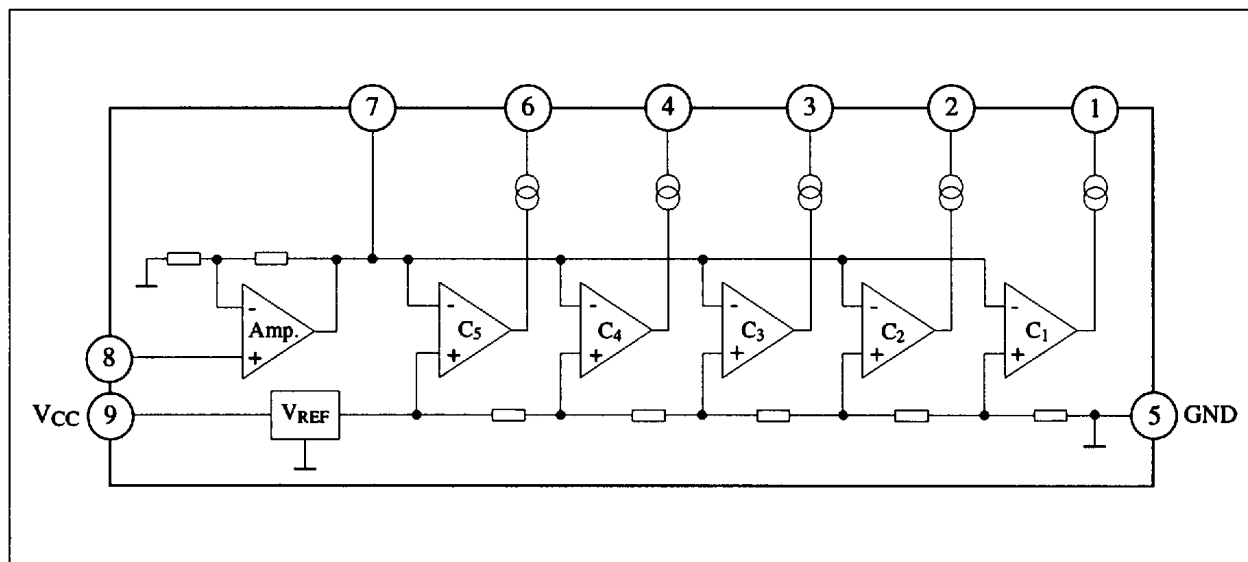

### ■ Absolute Maximum Ratings (Ta=25°C)

Item		Symbol	Rating		Unit
Voltage	Supply Voltage	V <sub>CC</sub>	18		V
	Circuit Voltage	V <sub>7-5</sub>	6		V
	Op. Amp. Input Voltage	V <sub>8-5</sub>	-0.5	V <sub>CC</sub>	V
	LED Output Pin Voltage	V <sub>1, 2, 3, 4, 6-5</sub>	V <sub>CC</sub>		V
Current	Supply Current	I <sub>CC</sub>	12		mA
	LED Output Pin Current	I <sub>1, 2, 3, 4, 6</sub>	20		mA
Power Dissipation *		P <sub>D</sub>	1100		mW
Operating Ambient Temperature		T <sub>opr</sub>	-25 ~ +75		°C
Storage Temperature		T <sub>stg</sub>	-55 ~ +125		°C

Operating Supply Voltage Range: V<sub>CC</sub> = 3.5V ~ 16.0V

\*Under Ta > 25°C, reduce at -11mW/°C

### ■ Electrical Characteristics (V<sub>CC</sub>=3V, Ta=25°C)

Item	Symbol	Test Circuit	Condition	min.	typ.	max.	Unit	
Supply Current	I <sub>CC</sub>	1	V <sub>8-5</sub> = 0V		6	8.5	mA	
Input Bias Current	I <sub>Bias8</sub>	2		-1		0	μA	
Output Sink Current	I <sub>(SINK)1, 2, 3, 4, 6</sub>	3	V <sub>8-5</sub> = 0.15V	11	15	18.5	mA	
Voltage Gain	G <sub>V</sub>	4	V <sub>8-5</sub> = 0.1V, R <sub>7</sub> = 10kΩ	24	26	28	dB	
Comparator Level	GD <sub>1</sub>	5	Pin 1	V <sub>8-5</sub> = 0V	-12	-10	-8	dB
	GD <sub>2</sub>	5	Pin 2		-6	-5	-4	dB
	GD <sub>3</sub>	5	Pin 3			0		dB
	GD <sub>4</sub>	5	Pin 4		2.5	3	3.5	dB
	GD <sub>5</sub>	5	Pin 6		5	6	7	dB

\*G<sub>D3</sub> LED ON level adjusting point = 0dB, equivalent to V<sub>7-5</sub> = 1.1V typ. (V<sub>8-5</sub> = 57mV)

### ■ Pin

Pin No.	Pin Name
1	LED 1 Output
2	LED 2 output
3	LED 3 Output
4	LED 4 Output
5	GND
6	LED 5 Output
7	AMP. Output
8	AMP. Input
9	V <sub>CC</sub>

Test Circuit 1 ( $I_{CC}$ )

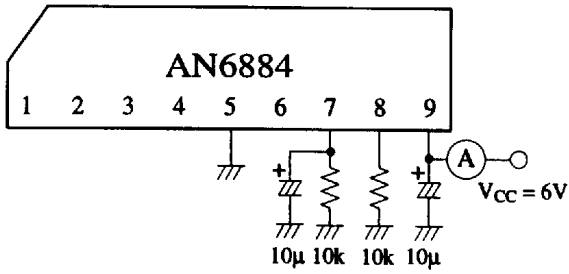

Test Circuit 2 ( $I_{Bias8}$ )

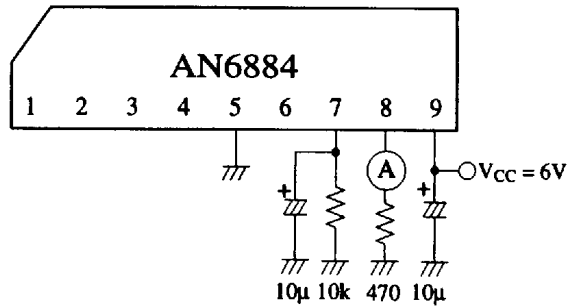

Test Circuit 3 ( $I_{(SINK)1, 2, 3, 4, 6}$ )

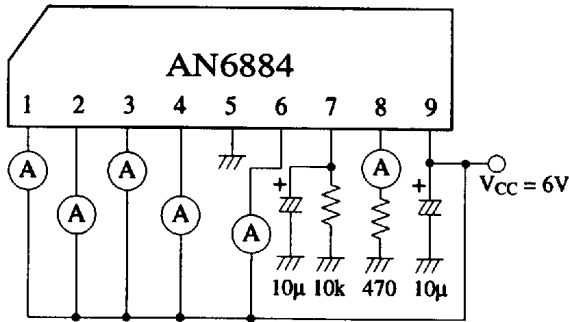

Test Circuit 4 ( $G_V$ )

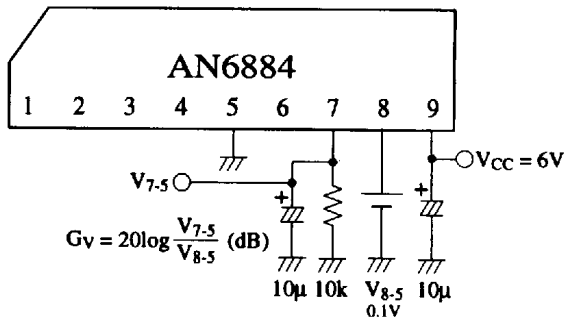

Test Circuit 5 ( $GD_{1-5}$ )

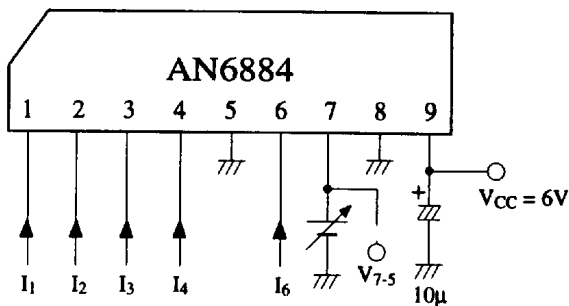

Note) Measure input voltage  $V_{7.5}$  of comparator that  $I_1$ - $I_5$  flow more than 11mA.

## Application Circuit

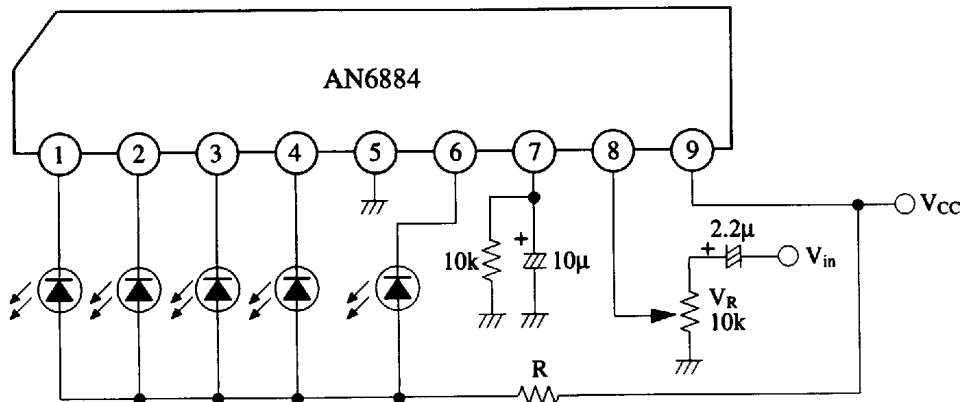

In case of  $T_a(\text{max}) = 60^\circ\text{C}$

$V_{CC}(\text{V})$	$R(\Omega)$
8 ~ 12	47
10 ~ 14	68
12 ~ 16	91

In case of  $T_a(\text{max.}) = 75^\circ\text{C}$

$V_{CC}(\text{V})$	$R(\Omega)$
7 ~ 9	27
8 ~ 10	39
9 ~ 11	51
10 ~ 12	62
11 ~ 13	75
12 ~ 14	82
13 ~ 15	100
14 ~ 16	110

## $P_D$ and $V_{CC}$

When maximum ambient temperature  $T_a(\text{max.}) = 60^\circ\text{C}$ ,  $V_{CC} > 9\text{V}$  /  $T_a(\text{max.}) = 75^\circ\text{C}$ ,  $V_{CC} > 7\text{V}$ ,  $P_D$  is over at the application circuit above. Select R value from the right list. And determine R watt by resistance value and total LED current.

## Characteristics Curve

