

MECHANICAL DATA

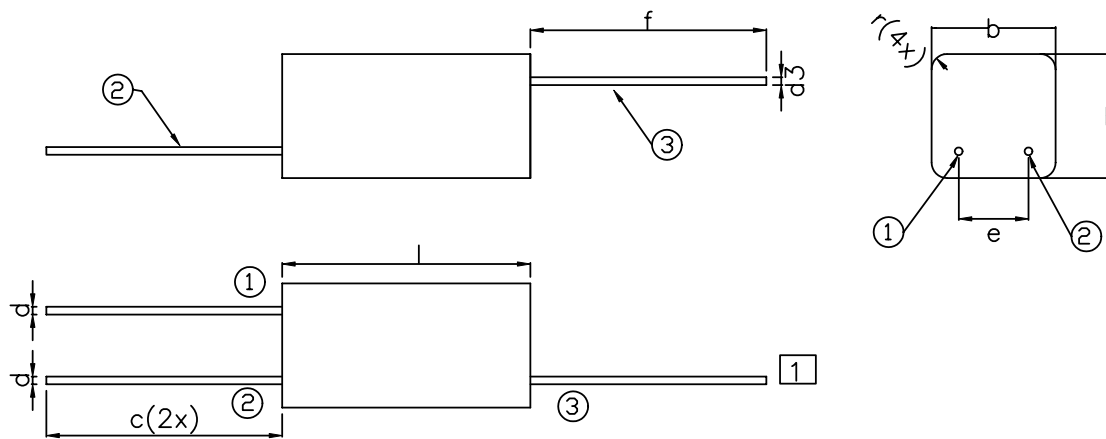

Note : Wire without insulation.

Dimensions (mm)

e : 4.5+/-1.5	c : 50+/-5	:
l : 16+/-0.5	f : 50+/-5	:
d : 0.6 Dia	n :	:
r : R1.5	k :	:
a :	d3: 0.5 Dia	:
b : 8.0+/-0.3	:	:

Pin no.1	Primary	Pin no.2	Primary & Secondary
Pin no.3	Secondary High Voltage		

Remarks :

Operating temp.: -30°C to +150°C

Storage temp.: -10°C to +80°C

				Number of sheets	Sheet no.
				2	1
				Date	Sign.
				7.8.01	Chong SP
				Drawn by	
				Checked by	
				Type	
1	1/1 X 1	16/8/02	PK NG	ZS 1052-10B UL	
Index	Changes	Date	Sign.		



47 Ayer Rajah Crescent #06-12
 Singapore 139947
 Tel : (065) 67752022
 Fax : (065) 67782370

OPERATING DATA

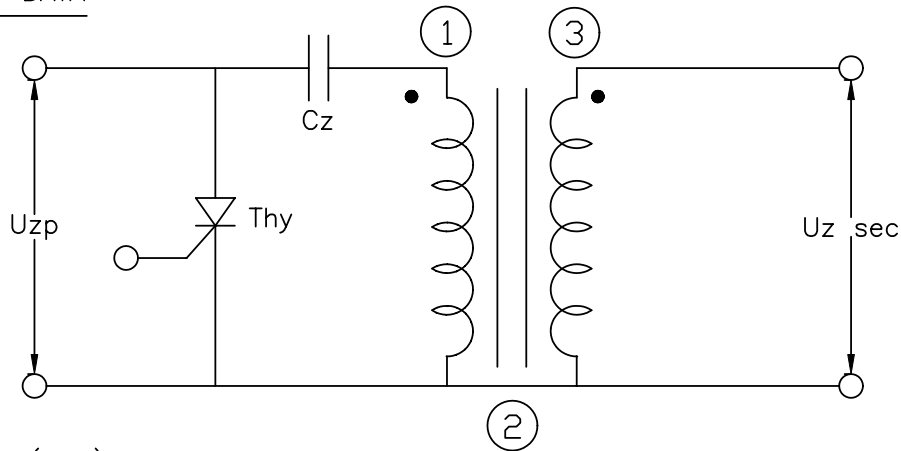

Dimensions (mm)

ITEMS	PRIMARY	SECONDARY
Resistance	325 mohm max	150+/-15 ohm
Primary Voltage, Uzp	Uzp = 300V	---
Primary Capacitance, Cz	0.047 uF	---
Secondary Voltage, Uz	---	9.5 kV min
Polarity of 1st peak	---	1st peak Negative
Inductance @ 1kHz	20+/-4 uH	20+/-5 mH

Typical waveform :

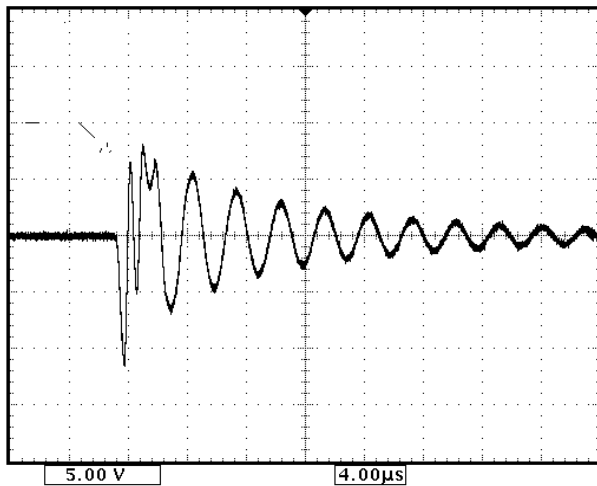

Unloaded high voltage output
4 us/div 5 kV/div

				Number of sheets		Sheet no.	
				2		2	
				Date		Sign.	
				7.8.01		Chong SP	
				Drawn by		Checked by	
				Type			
				ZS 1052-10B UL			
1	1/1 X 1	16/8/02	PK NG				
Index	Changes	Date	Sign.				



47 Ayer Rajah Crescent #06-12
Singapore 139947
Tel : (065) 67752022
Fax : (065) 67782370