

TaNFilm® Chip Carrier Resistor Network

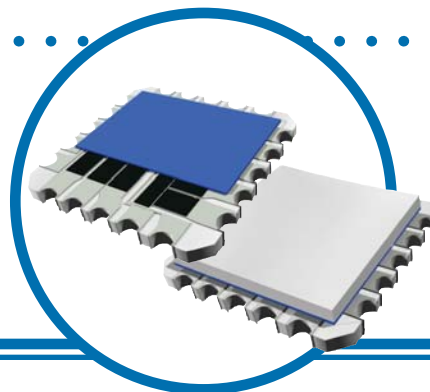

CCN Series

- Qualified to DESC 87016 and 87017 military specifications
- Gold, Sn/Pb and RoHS compliant terminations available
- Ideal for all reflow soldering techniques
- Meet JEDEC standard for type 'C' package
- Custom schematics readily available
- Absolute TCR to ± 15 ppm/ $^{\circ}\text{C}$



The IRC TaNFilm® Chip Carrier Network offers higher lead density, increased component count, lower installed resistor cost, better reliability, and is ideal for use with all surface mount solder techniques. In addition, the TaNFilm® leadless CCN provides all the unique qualities of our other TaNFilm® package configurations. Testing has demonstrated performance exceeding MIL-PRF-914 Characteristic H.

Precise state-of-the-art laser trimming provides close tolerances and tight ratios. The TaNFilm® process enables IRC to manufacture custom circuit configurations and multiple resistance values without sacrificing the tightest tolerance and tracking characteristics of precision networks. The Tantalum Nitride resistor material is passivated for environmental protection surpassing military requirements and guaranteeing exceptional ratio stability.

For applications requiring a high degree of reliability, stability, accuracy and low noise, plus the advantages of new resistor configurations, specify the IRC Leadless Chip Carrier Configuration Resistor Network.

Electrical Data

Resistance Range	10 Ω to 300K Ω
Absolute Resistance Tolerance	To $\pm 0.1\%$
Ratio Tolerance to R1	to $\pm 0.01\%$
Power Rating @ 70$^{\circ}\text{C}$	0.1 watt/resistor, 1.0 watt/network
Operating Temperature Range	-55 $^{\circ}\text{C}$ to +150 $^{\circ}\text{C}$
Absolute TCR	To ± 15 ppm/ $^{\circ}\text{C}$
TCR Tracking	To ± 5 ppm/ $^{\circ}\text{C}$
Noise	Less than -25 dB
Termination Options (nickel leach barrier)	Gold 60/40 Sn/Pb 100% matte-tin
Substrate Material	99.5% pure alumina substrate
Construction	Epoxy overcoat (78xx) Ceramic lid (79xx)

Custom circuits and special testing available.

General Note

IRC reserves the right to make changes in product specification without notice or liability. All information is subject to IRC's own data and is considered accurate at time of going to print.

© IRC Advanced Film Division • 4222 South Staples Street • Corpus Christi Texas 78411 USA
Telephone: 361 992 7900 • Facsimile: 361 992 3377 • Website: www.irctt.com



A subsidiary of
TT electronics plc

CCN Series Issue April 2009 Sheet 1 of 4

TaNFilm® Chip Carrier Resistor Network



Manufacturing Capability Data

Circuit	Resistance Range	Available Absolute Tolerances	Available Ratio Tolerances (Ratio to R1)	Best Absolute TCR	Tracking TCR (Track to R1)
Isolated Schematics 7907/7807 7908/7808	10Ω - 24.9Ω	F G J	D F G	±300 ppm/°C	±50 ppm/°C
	25.0Ω - 49.9Ω	F G J	D F G	±100 ppm/°C	±25 ppm/°C
	50Ω - 199Ω	D F G J	B D F G	±50 ppm/°C	±10 ppm/°C
	200Ω - 999Ω	B D F G J	B D F G	±25 ppm/°C	±5 ppm/°C
	1.0K - 50.0K	B D F G J	A B D F G	±25 ppm/°C	±5 ppm/°C
Isolated Schematic 7909/7809	10Ω - 24.9Ω	F G J	D F G	±300 ppm/°C	±50ppm/°C
	25Ω - 74.9Ω	F G J	D F G	±100 ppm/°C	±25 ppm/°C
	75Ω - 379Ω	D F G J	B D F G	±50 ppm/°C	±10 ppm/°C
	380Ω - 999Ω	B D F G J	A B D F G	±25 ppm/°C	±5 ppm/°C
	1.0KΩ - 100KΩ	B D F G J	T Q A B D F G	±25 ppm/°C	±5 ppm/°C
	101KΩ - 250KΩ	B D F G J	A B D F G	±25 ppm/°C	±5 ppm/°C
Bussed Schematic 7900/7800	10Ω - 24.9Ω	F G J	D F G	±300 ppm/°C	±50ppm/°C
	25Ω - 74.9Ω	F G J	D F G	±100 ppm/°C	±25ppm/°C
	75Ω - 149Ω	F G J	B D F G	±50 ppm/°C	±10ppm/°C
	150Ω - 100KΩ	B D F G J	A B D F G	±25 ppm/°C	±5ppm/°C

Physical Data

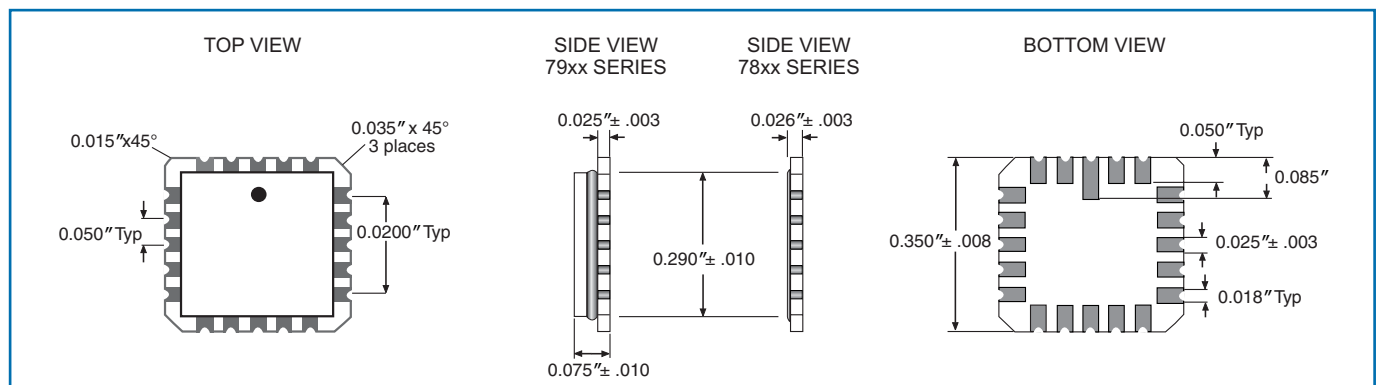

TaNFilm[®] Chip Carrier Resistor Network



Schematic Data

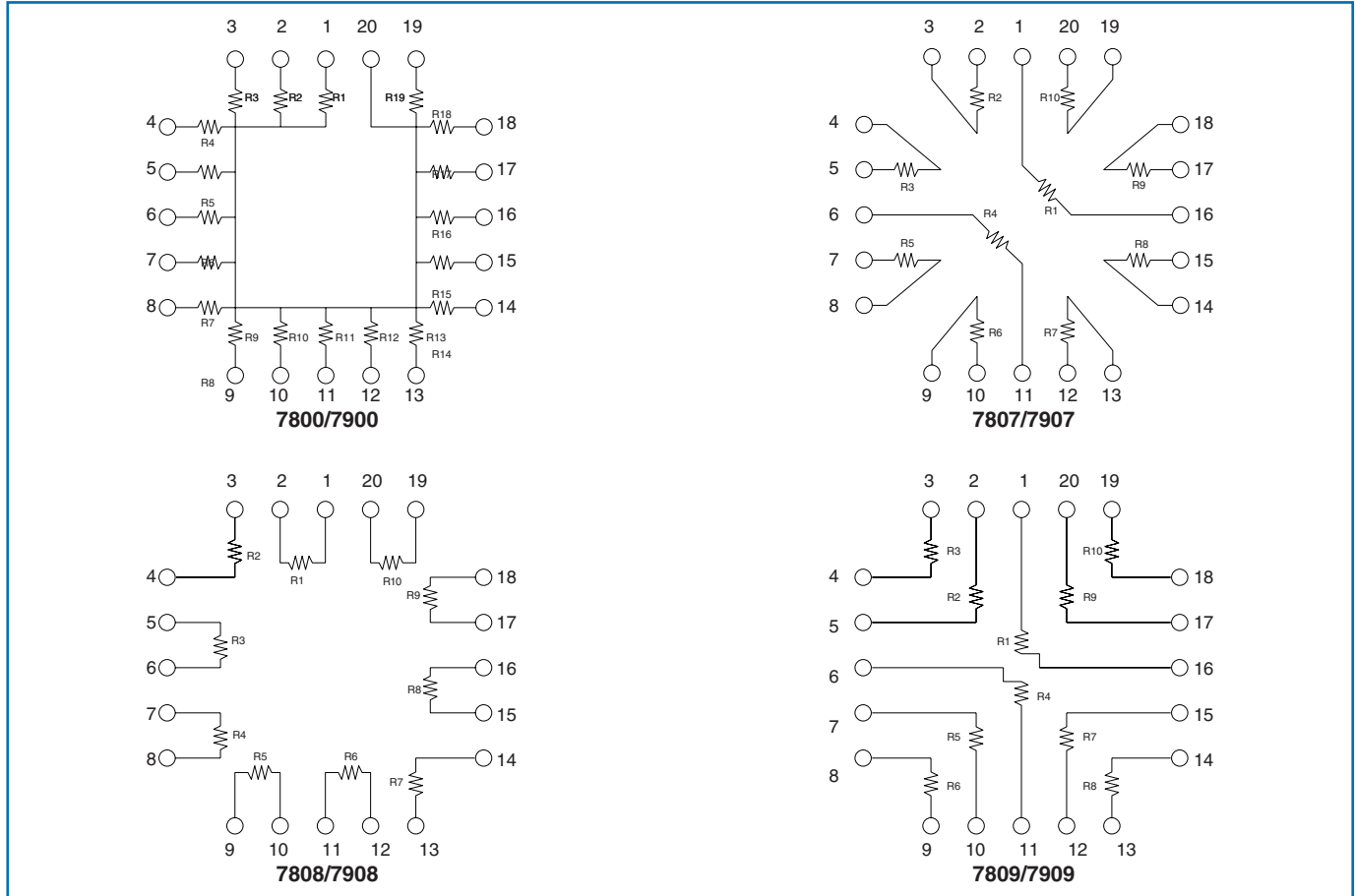

Environmental Data

Test Per MIL-PRF-914	MIL-PRF-914 Limits ($\Delta R\%$)				TaNFilm [®] Test Data ($\Delta R\%$)	
	M	K	H	V	Max	Typical
Thermal Shock and Power Conditioning	0.7	0.7	0.5	0.25	0.1	0.02
Low Temperature Operation	0.5	0.25	0.1	0.1	0.05	0.02
Short Term Overload	0.5	0.25	0.1	0.1	0.05	0.02
Resistance to Bonding Exposure	0.25	0.25	0.25	0.25	0.1	0.02
Steady State Humidity	0.5	0.5	0.5	0.2	0.1	0.03
Moisture Resistance	0.5	0.5	0.4	0.25	0.1	0.03
Shock	0.25	0.25	0.25	0.25	0.1	0.03
Vibration	0.25	0.25	0.25	0.25	0.1	0.03
Life	2.0	0.5	0.5	0.5	0.1	0.03
High Temperature Exposure	1.0	0.5	0.2	0.1	0.1	0.03
Low Temperature Storage	0.5	0.25	0.1	0.1	0.05	0.01

TaNFilm[®] Chip Carrier Resistor Network



Power Derating Data

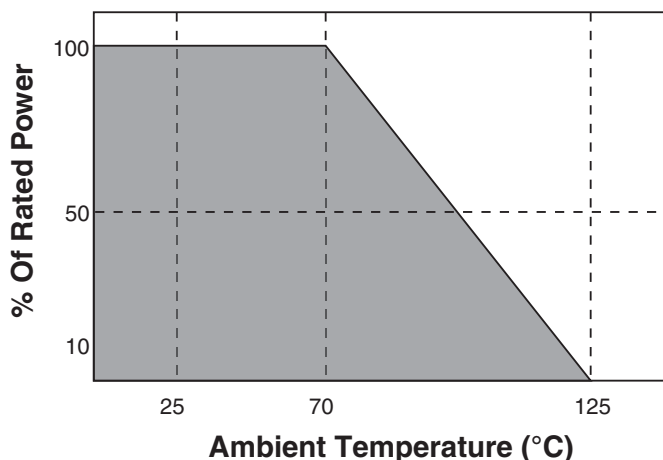

Ordering Data

Prefix **CCN** - **7900** - **01** - **1001** - **B** - **B**

Model
 7800: 20-pin, 19 resistor schematic, epoxy overcoat construction, 60/40 Sn/Pb solder plate terminations
 7800LF: 20-pin, 19 resistor schematic, epoxy overcoat construction, 100% matte-tin (Pb-free) terminations

7807: 20-pin, 10 resistor schematic, epoxy overcoat construction, 60/40 Sn/Pb solder plate terminations
 7807LF: 20-pin, 10 resistor schematic, epoxy overcoat construction, 100% matte-tin (Pb-free) terminations

7808: 20-pin, 10 resistor schematic, epoxy overcoat construction, 60/40 Sn/Pb solder plate terminations
 7808LF: 20-pin, 10 resistor schematic, epoxy overcoat construction, 100% matte-tin (Pb-free) terminations

7809: 20-pin, 10 resistor schematic, epoxy overcoat construction, 60/40 Sn/Pb solder plate terminations
 7809LF: 20-pin, 10 resistor schematic, epoxy overcoat construction, 100% matte-tin (Pb-free) terminations

7900: 20-pin, 19 resistor schematic, ceramic lid construction, gold over nickel plate terminations
 7900SD: 20-pin, 19 resistor schematic, ceramic lid construction, Sn/Pb hot solder dipped terminations
 7900LF: 20-pin, 19 resistor schematic, ceramic lid construction, 100% matte-tin (Pb-free) terminations

7907: 20-pin, 10 resistor schematic, ceramic lid construction, gold over nickel plate terminations
 7907SD: 20-pin, 10 resistor schematic, ceramic lid construction, Sn/Pb hot solder dipped terminations
 7907LF: 20-pin, 10 resistor schematic, ceramic lid construction, 100% matte-tin (Pb-free) terminations

7908: 20-pin, 10 resistor schematic, ceramic lid construction, gold over nickel plate terminations
 7908SD: 20-pin, 10 resistor schematic, ceramic lid construction, Sn/Pb hot solder dipped terminations
 7908LF: 20-pin, 10 resistor schematic, ceramic lid construction, 100% matte-tin (Pb-free) terminations

7909: 20-pin, 10 resistor schematic, ceramic lid construction, gold over nickel plate terminations
 7909SD: 20-pin, 10 resistor schematic, ceramic lid construction, Sn/Pb hot solder dipped terminations
 7909LF: 20-pin, 10 resistor schematic, ceramic lid construction, 100% matte-tin (Pb-free) terminations

TCR/Screening Code

Code	Classification	Absolute TCR
00	Commercial Grade	±300ppm/°C
01	Commercial Grade	±100ppm/°C
02	Commercial Grade	±50ppm/°C
03	Commercial Grade	±25ppm/°C
04	MIL-PRF-914M Screened	±300ppm/°C
05	MIL-PRF-914K Screened	±100ppm/°C
06	MIL-PRF-914H Screened	±50ppm/°C
07	MIL-PRF-914H Screened	±25ppm/°C
11	Commercial Grade	±15ppm/°C

Resistance Code

Standard 4-Digit MIL Resistance Code. Example: 1001 = 1000Ω, 50R0 = 50Ω

Absolute Tolerance Code

B = ±0.1%; D = ±0.5%; F = ±1%; G = ±2%; J = ±5%

Ratio Tolerance to R₁

T = ±0.01%; Q = ±0.02%; A = ±0.05%; B = ±0.1%; D = ±0.5%; F = ±1%; G = ±2%