

MODEL HM12 SERIES

Output Toroidal Inductors

with Mounting Base



FEATURES

- High performance powdered iron cores for excellent energy storage characteristics
- Cost effective design
- Custom designs available

APPLICATIONS

- Switching power supply
- Motor control circuit
- Differential EMI filter
- Output ripple current filter

ELECTRICAL / ENVIRONMENTAL

Insulation Resistance, Minimum	100 Megohms
Operating Temperature Range	-25°C to +105°C
Insulation System	Class B, 130°C

SCHEMATIC (FIGURE 1 & 2)

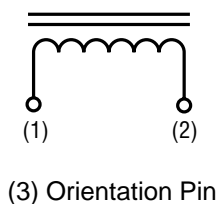

Specifications subject to change without notice.

FIGURE 1 (Inch/mm)

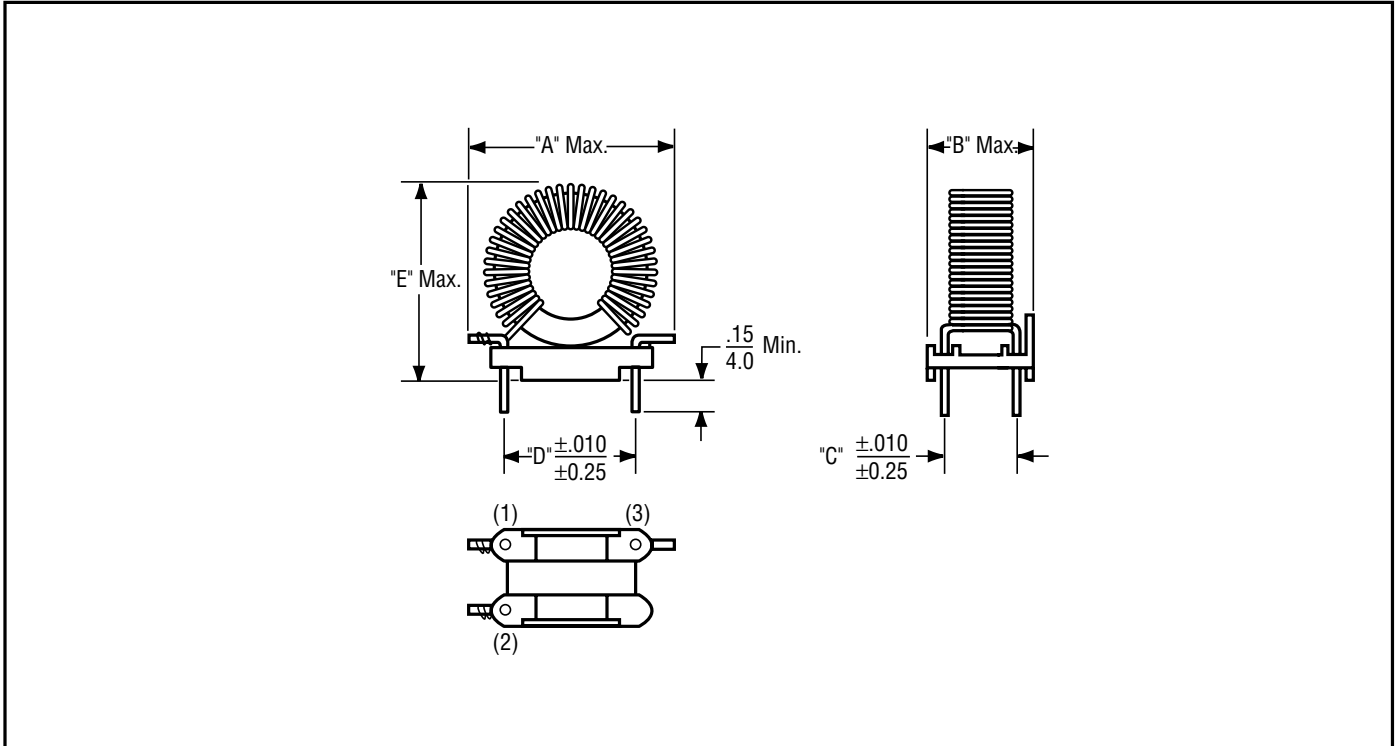
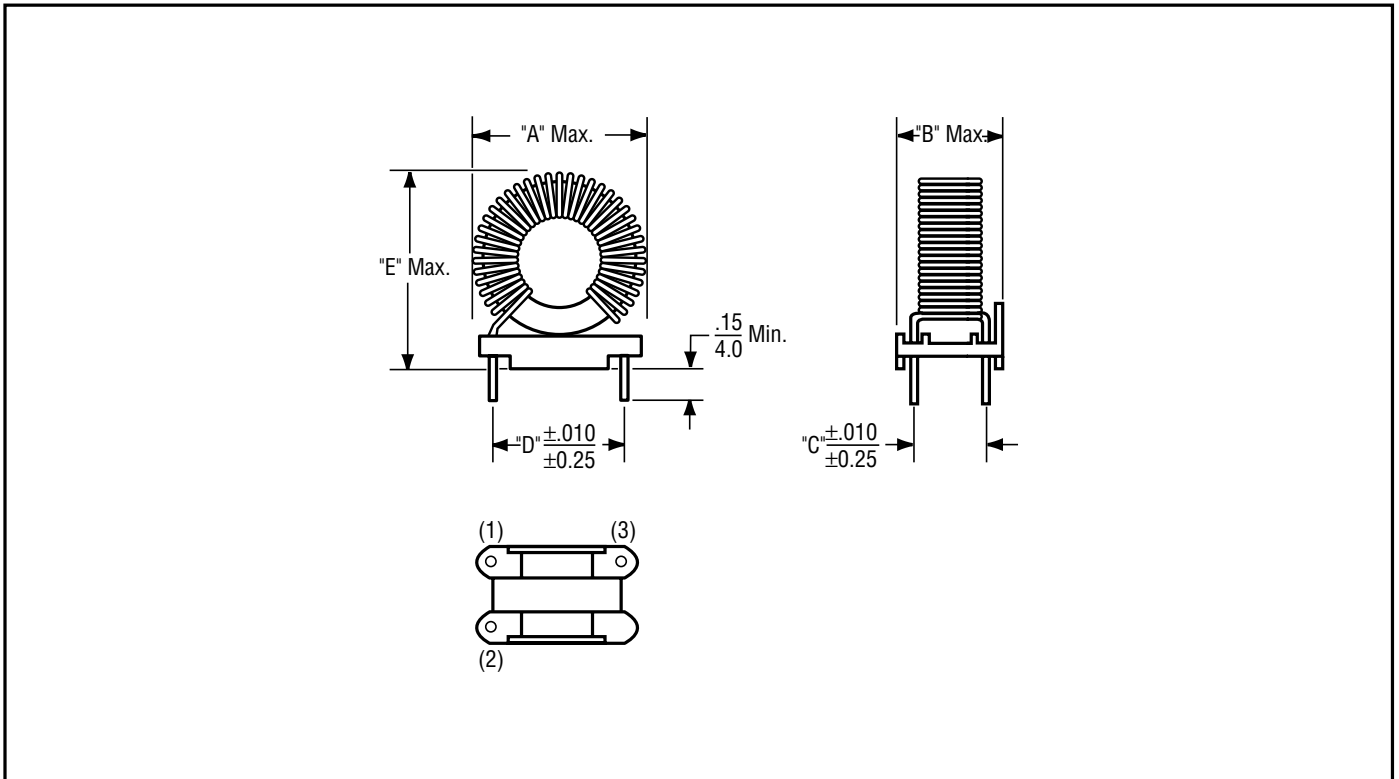

FIGURE 2 (Inch/mm)



SPECIFICATIONS (FIGURE 1)

Part Number	Inductance Typical μH	Current I_{DC} Amps Max.	DC Resistance Ω Max.	ET_{op} V- μSec	Energy Storage μJ Min.	Wire Gauge AWG (mm) ⁽¹⁾	Mechanical Outline Dimensions: Inch/mm				
							A	B	C	D	E
HM12-01001	92	1	0.35	77	46	$\frac{26}{(0.40)}$	$\frac{1.20}{30.5}$	$\frac{0.62}{15.8}$	$\frac{0.4}{10.16}$	$\frac{0.8}{20.32}$	$\frac{0.75}{19.05}$
HM12-01002	700	1	0.89	400	350	$\frac{26}{(0.40)}$	$\frac{1.20}{30.5}$	$\frac{0.62}{15.8}$	$\frac{0.4}{10.16}$	$\frac{0.8}{20.32}$	$\frac{1.2}{30.48}$
HM12-01003	1,700	1	1.45	730	850	$\frac{27}{(0.36)}$	$\frac{1.67}{42.5}$	$\frac{0.93}{23.6}$	$\frac{0.7}{17.78}$	$\frac{1.2}{30.48}$	$\frac{1.58}{40.13}$
HM12-02501	77	2.5	0.11	90	240	$\frac{24}{(0.51)}$	$\frac{1.20}{30.5}$	$\frac{0.62}{15.8}$	$\frac{0.4}{10.16}$	$\frac{0.96}{24.38}$	$\frac{0.95}{24.13}$
HM12-02502	320	2.5	0.29	350	1,000	$\frac{23}{(0.57)}$	$\frac{1.45}{36.8}$	$\frac{0.83}{21.1}$	$\frac{0.6}{15.24}$	$\frac{0.9}{22.86}$	$\frac{1.35}{34.30}$
HM12-02503	960	2.5	0.63	870	3,000	$\frac{23}{(0.57)}$	$\frac{2.30}{58.4}$	$\frac{1.12}{28.5}$	$\frac{0.9}{22.86}$	$\frac{1.5}{38.1}$	$\frac{1.85}{47.0}$

SPECIFICATIONS (FIGURE 2)

Part Number	Inductance Typical μH	Current I_{DC} Amps Max.	DC Resistance Ω Max.	ET_{op} V- μSec	Energy Storage μJ Min.	Wire Gauge AWG (mm) ⁽¹⁾	Mechanical Outline Dimensions: Inch/mm				
							A	B	C	D	E
HM12-03501	275	4	0.200	500	2,200	$\frac{19}{(0.91)}$	$\frac{1.45}{36.8}$	$\frac{0.90}{22.9}$	$\frac{0.60}{15.24}$	$\frac{0.90}{22.86}$	$\frac{1.40}{38.7}$
HM12-03502	475	4	0.130	600	2,138	$\frac{18}{(1.02)}$	$\frac{1.60}{40.6}$	$\frac{0.83}{21.1}$	$\frac{0.60}{15.24}$	$\frac{0.90}{22.86}$	$\frac{1.72}{43.7}$
HM12-06001	35	6	0.025	200	630	$\frac{18}{(1.02)}$	$\frac{1.20}{30.5}$	$\frac{0.62}{15.8}$	$\frac{0.40}{10.16}$	$\frac{0.80}{20.32}$	$\frac{1.20}{30.5}$
HM12-06002	100	6	0.048	400	1,800	$\frac{18}{(1.02)}$	$\frac{1.60}{40.6}$	$\frac{0.83}{21.1}$	$\frac{0.60}{15.24}$	$\frac{0.90}{22.86}$	$\frac{1.56}{39.6}$
HM12-06003	180	6	0.068	620	3,240	$\frac{18}{(1.02)}$	$\frac{1.95}{49.5}$	$\frac{0.93}{23.5}$	$\frac{0.70}{17.78}$	$\frac{1.20}{30.48}$	$\frac{2.00}{50.80}$
HM12-06004	330	6	0.095	840	5,940	$\frac{18}{(1.02)}$	$\frac{2.30}{58.4}$	$\frac{1.11}{28.2}$	$\frac{0.90}{22.85}$	$\frac{1.50}{38.10}$	$\frac{2.30}{58.4}$
HM12-07001	50	7	0.032	230	1,225	$\frac{18}{(1.02)}$	$\frac{1.44}{36.8}$	$\frac{0.83}{21.1}$	$\frac{0.60}{15.24}$	$\frac{0.90}{22.86}$	$\frac{1.44}{36.6}$
HM12-07501	178	7.5	0.075	500	5,000	$\frac{18}{(1.02)}$	$\frac{2.30}{58.4}$	$\frac{1.12}{28.5}$	$\frac{0.9}{22.86}$	$\frac{1.5}{38.1}$	$\frac{1.90}{48.3}$
HM12-10001	15	10	0.009	135	750	$\frac{15}{(1.45)}$	$\frac{1.20}{30.5}$	$\frac{0.62}{15.8}$	$\frac{0.40}{10.16}$	$\frac{0.80}{20.34}$	$\frac{1.20}{30.5}$
HM12-10002	25	10	0.012	170	1,250	$\frac{15}{(1.45)}$	$\frac{1.44}{36.6}$	$\frac{0.83}{21.1}$	$\frac{0.60}{15.24}$	$\frac{0.90}{22.86}$	$\frac{1.44}{36.6}$
HM12-10003	45	10	0.018	280	2,250	$\frac{15}{(1.45)}$	$\frac{1.60}{40.6}$	$\frac{0.83}{21.1}$	$\frac{0.60}{15.24}$	$\frac{0.90}{22.86}$	$\frac{1.72}{43.7}$
HM12-10004	75	10	0.025	430	3,750	$\frac{15}{(1.45)}$	$\frac{1.95}{49.5}$	$\frac{0.96}{24.4}$	$\frac{0.70}{17.78}$	$\frac{1.20}{30.48}$	$\frac{2.00}{50.8}$
HM12-10005	150	10	0.032	570	7,500	$\frac{15}{(1.45)}$	$\frac{2.30}{58.4}$	$\frac{1.11}{28.2}$	$\frac{0.90}{22.85}$	$\frac{1.50}{38.10}$	$\frac{2.30}{58.4}$
HM12-15001	35	15	0.009	290	3,935	$\frac{12}{(2.05)}$	$\frac{1.95}{49.5}$	$\frac{0.93}{23.5}$	$\frac{0.70}{17.78}$	$\frac{1.20}{30.48}$	$\frac{2.00}{50.8}$
HM12-15002	65	15	0.012	390	7,310	$\frac{12}{(2.05)}$	$\frac{2.30}{58.4}$	$\frac{1.11}{28.2}$	$\frac{0.90}{22.95}$	$\frac{1.50}{38.10}$	$\frac{2.30}{58.4}$
HM12-16001	20	16	0.0065	190	2,560	$\frac{12}{(2.05)}$	$\frac{1.60}{40.6}$	$\frac{1.11}{28.2}$	$\frac{0.60}{15.24}$	$\frac{0.90}{22.86}$	$\frac{1.72}{43.7}$

Note: (1) Nominal bare wire diameter.