

Application

LNA and wide band amplifier up to GHz range

 Features
 Low Noise Figure

NF = 1.5 dB at $f = 2$ GHz, $V_{CE} = 3$ V, $I_C = 5$ mA

NF = 1.7 dB at $f = 2$ GHz, $V_{CE} = 1$ V, $I_C = 3$ mA

 High Gain

MAG = 13.5 dB at $f = 2$ GHz, $V_{CE} = 3$ V, $I_C = 20$ mA

MAG = 13 dB at $f = 2$ GHz, $V_{CE} = 1$ V, $I_C = 3$ mA

 High Transition Frequency

$f_T = 16.5$ GHz at $V_{CE} = 3$ V, $I_C = 20$ mA

SOT-523 Unit in mm

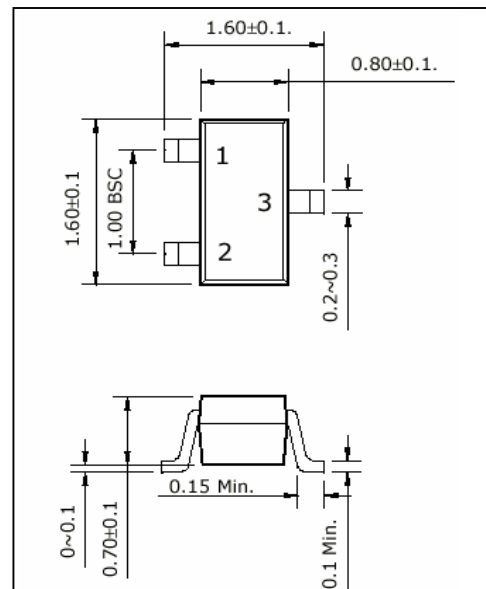
 Pin Configuration

Pin No	Symbol	Description
1	B	Base
2	E	Emitter
3	C	Collector

 h_{FE} Classification

Marking	AG1	AG2
h_{FE}	125 to 300	80 to 160

 Available Package

Unit : mm

Product	Package	Dimension
THN4201U	SOT-323	2.0 x 1.25, 1.0t
THN4201Z	SOT-343	2.0 x 1.25, 1.0t
THN4201E	SOT-523	1.6 x 0.8, 0.8t

 Absolute Maximum Ratings

Symbol	Parameter	Ratings	Unit
V_{CBO}	Collector to Base Breakdown Voltage	15	V
V_{CEO}	Collector to Emitter Breakdown Voltage	6	V
V_{EBO}	Emitter to Base Breakdown Voltage	2.5	V
I_C	Collector Current (DC)	35	mA
P_T	Total Power Dissipation	150	mW
T_{STG}	Storage Temperature	-65 ~ 150	°C
T_J	Operating Junction Temperature	150	°C

Caution : ESD sensitive device

THN4201 Series

□ Electrical Characteristics ($T_A = 25\text{ }^\circ\text{C}$)

Symbol	Parameter	Test Condition	Value			Unit
			Min.	Typ.	Max.	
I_{CBO}	Collector Cut-off Current	$V_{CB} = 10\text{ V}, I_E = 0\text{ mA}$	-	-	0.5	μA
I_{CEO}		$V_{CE} = 6\text{ V}, I_B = 0\text{ mA}$	-	-	5	μA
I_{EBO}	Emitter Cut-off Current	$V_{EB} = 1\text{ V}, I_C = 0\text{ mA}$	-	-	0.5	μA
h_{FE}	DC Current Gain	$V_{CE} = 3\text{ V}, I_C = 15\text{ mA}$	80	200	300	
f_T	Transition Frequency	$V_{CE} = 3\text{ V}, I_C = 20\text{ mA}$	-	16.5	-	GHz
C_{CB}	Collector to Base Capacitance	$V_{CB} = 10\text{ V}, f = 1\text{ MHz}$	-	0.48	-	pF
$ S_{21} ^2$	Insertion Power Gain	$V_{CE} = 3\text{ V}, I_C = 15\text{ mA}, f = 2\text{ GHz}$	7.5	9.5	-	dB
		$V_{CE} = 1\text{ V}, I_C = 10\text{ mA}, f = 2\text{ GHz}$	6	8.5	-	
MAG	Maximum Available Gain	$V_{CE} = 3\text{ V}, I_C = 15\text{ mA}, f = 2\text{ GHz}$	12	13.5	-	dB
		$V_{CE} = 1\text{ V}, I_C = 10\text{ mA}, f = 2\text{ GHz}$	12	13	-	
NFmin	Minimum Noise Figure	$V_{CE} = 3\text{ V}, I_C = 5\text{ mA}, f = 2\text{ GHz}$	-	1.5	-	dB
		$V_{CE} = 1\text{ V}, I_C = 3\text{ mA}, f = 2\text{ GHz}$	-	1.7	-	
rn	Noise Resistance	$V_{CE} = 3\text{ V}, I_C = 5\text{ mA}, f = 2\text{ GHz}$	-	0.04	-	Ω
		$V_{CE} = 1\text{ V}, I_C = 3\text{ mA}, f = 2\text{ GHz}$	-	0.05	-	
G_A	Associated Gain	$V_{CE} = 3\text{ V}, I_C = 5\text{ mA}, f = 2\text{ GHz}$	-	10	-	dB
		$V_{CE} = 1\text{ V}, I_C = 3\text{ mA}, f = 2\text{ GHz}$	-	8.5	-	

THN4201 Series

Total Power Dissipation, P_T vs. T_A

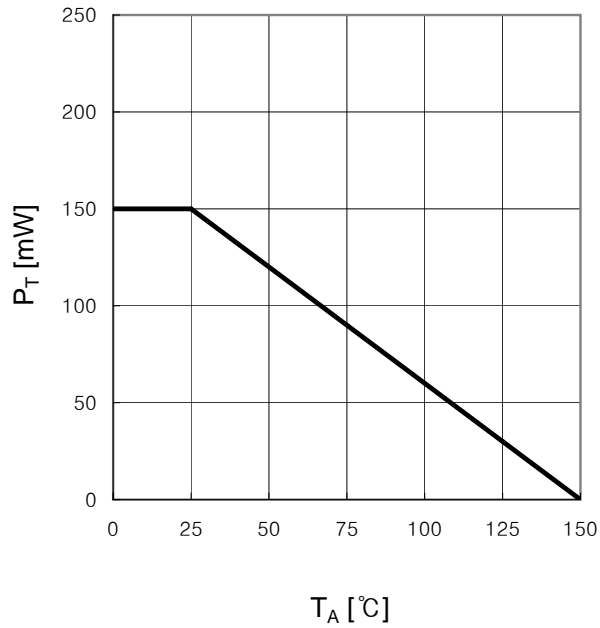

I_C vs. V_{CE}

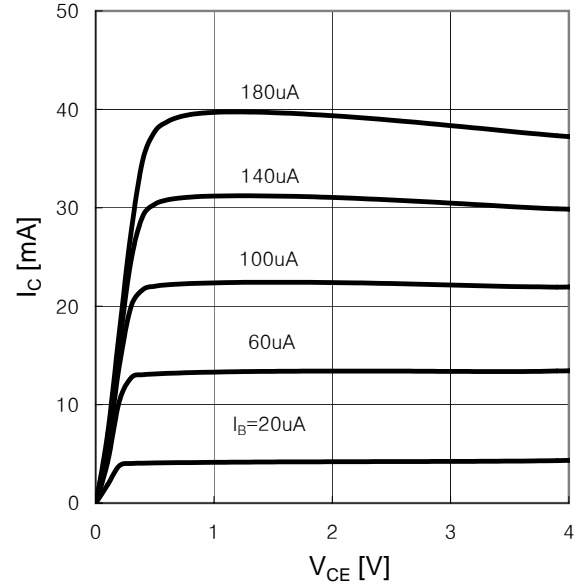

I_C vs. V_{BE}

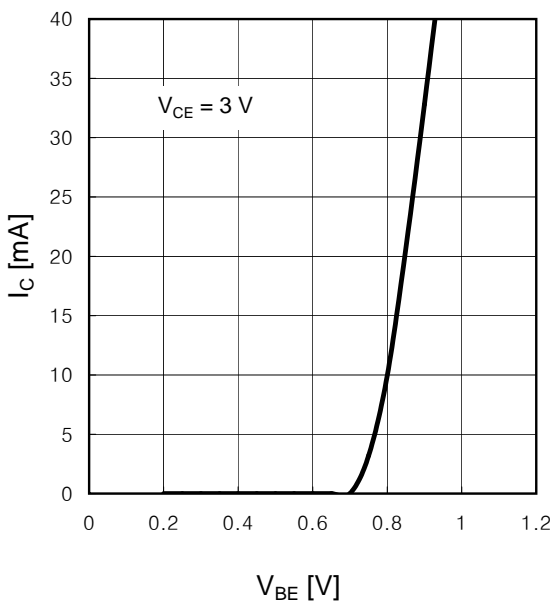

h_{FE} vs. I_C

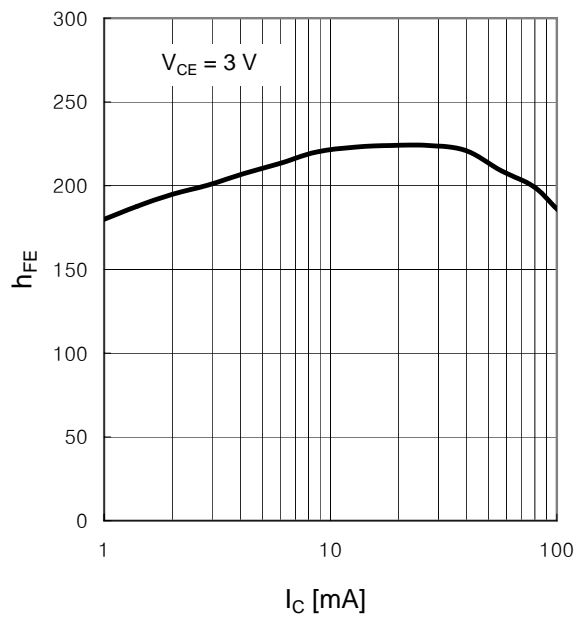

THN4201 Series

Maximum Available Gain, MAG vs. Frequency

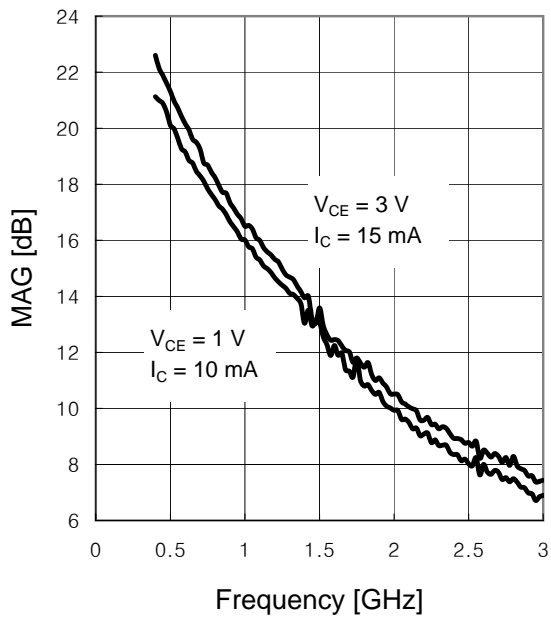

Insertion Power Gain, $|S_{21}|^2$ vs. Frequency

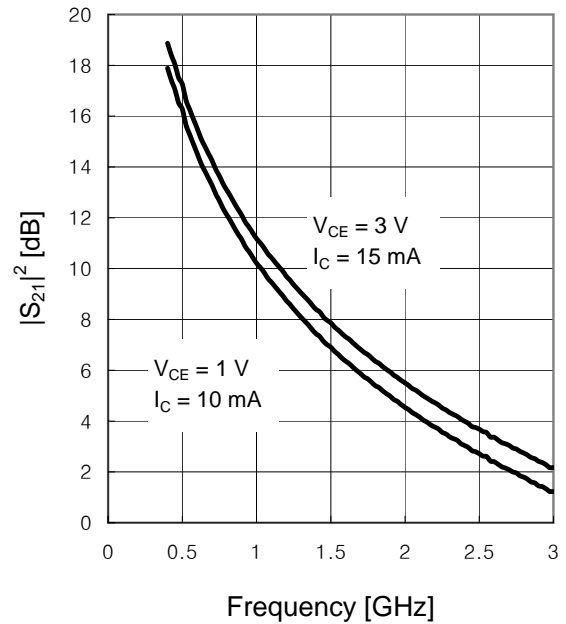

Maximum Available Gain, MAG vs. I_C

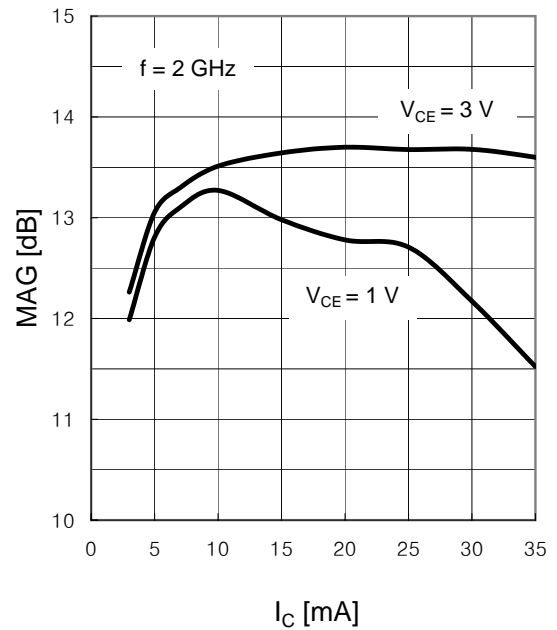
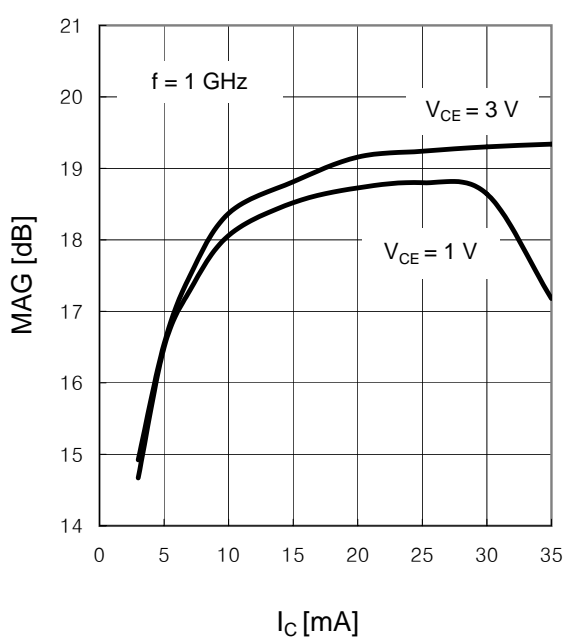

THN4201 Series

Transition Frequency, f_T vs. I_C

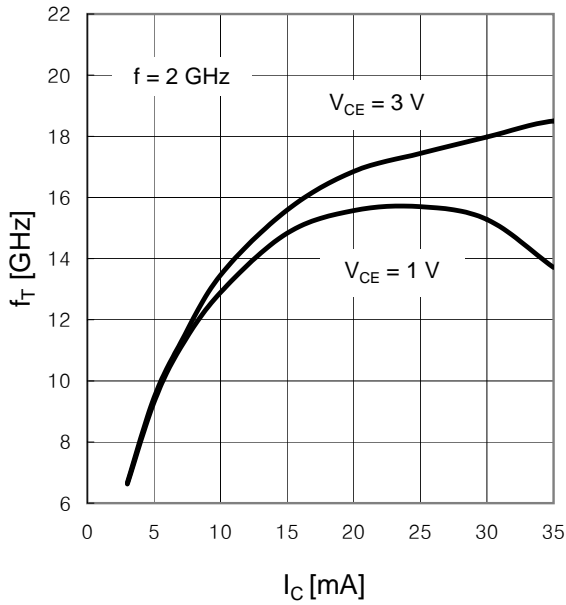

C_{CB} vs. V_{CB}

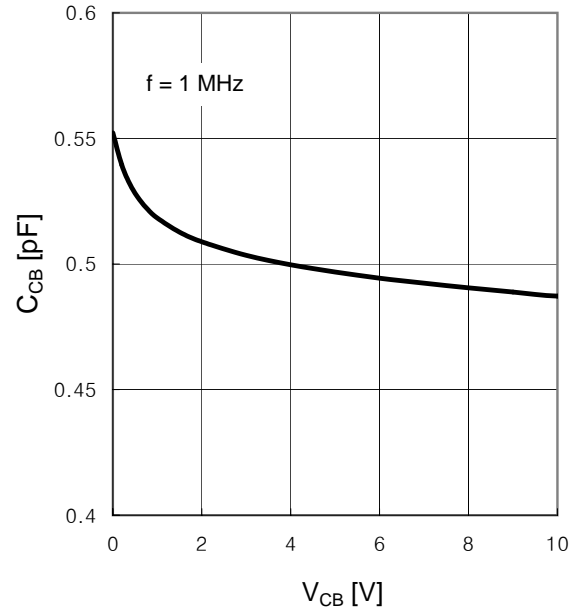

NF vs. I_C

$V_{CE} = 3\text{ V}$, $I_C = \text{parameter}$, $Z_S = Z_{\text{Sopt}}$

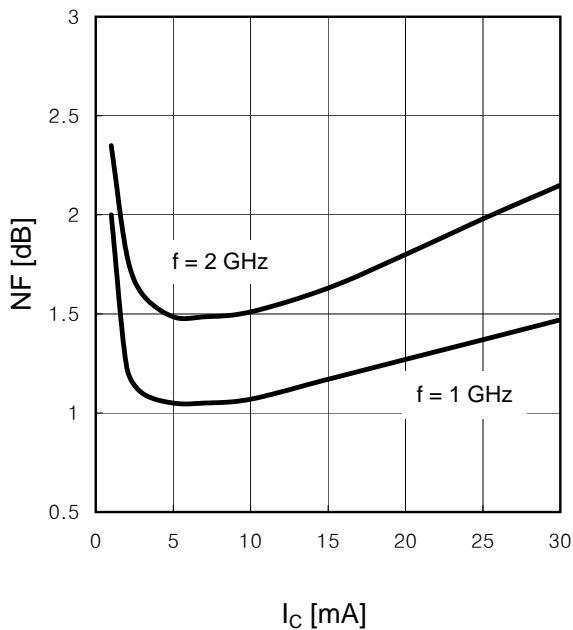

Noise Figure Contours & Constant Gain

$f = 1\text{ GHz}$ or 2 GHz , $V_{CE} = 3\text{ V}$, $I_C = 5\text{ mA}$

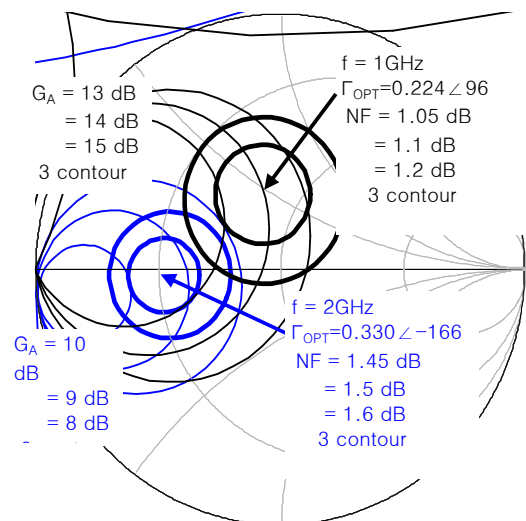

THN4201 Series

□ Dimensions of THN4201U in mm

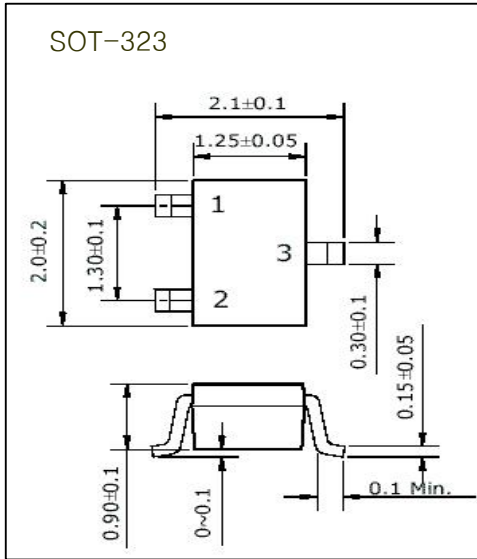

Pin Configuration

Pin No	Symbol	Description
1	B	Base
2	E	Emitter
3	C	Collector

□ Dimensions of THN4201Z in mm

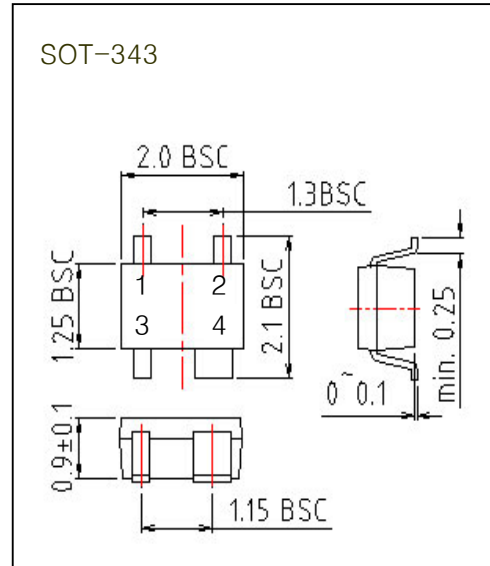

Pin Configuration

Pin No	Symbol	Description
1	B	Base
2, 3	E	Emitter
4	C	Collector

THN4201 Series

□ Common Emitter S-Parameter Data

at $V_{CE} = 3\text{ V}$, $I_C = 3\text{ mA}$

freq	S(1,1)	S(2,1)	S(1,2)	S(2,2)
400.0MHz	0.742 / -77.176	7.389 / 124.972	0.102 / 45.073	0.745 / -57.758
600.0MHz	0.667 / -100.184	5.796 / 109.483	0.119 / 34.053	0.637 / -75.073
800.0MHz	0.620 / -116.294	4.667 / 97.992	0.122 / 27.423	0.564 / -86.984
1.000GHz	0.587 / -128.998	3.877 / 88.979	0.125 / 24.945	0.527 / -96.913
1.200GHz	0.569 / -138.431	3.310 / 81.406	0.126 / 22.698	0.512 / -103.269
1.400GHz	0.555 / -146.506	2.871 / 74.698	0.125 / 22.441	0.505 / -109.756
1.600GHz	0.554 / -153.379	2.541 / 68.656	0.124 / 23.294	0.503 / -114.944
1.800GHz	0.549 / -159.830	2.278 / 63.122	0.123 / 23.830	0.510 / -119.188
2.000GHz	0.553 / -165.356	2.054 / 57.959	0.122 / 25.325	0.518 / -123.989
2.200GHz	0.554 / -170.867	1.874 / 53.099	0.122 / 27.924	0.529 / -128.333
2.400GHz	0.557 / -175.909	1.716 / 48.594	0.126 / 30.854	0.540 / -132.205
2.600GHz	0.567 / 179.205	1.585 / 44.293	0.129 / 34.156	0.556 / -136.402
2.800GHz	0.573 / 173.300	1.468 / 39.818	0.132 / 36.425	0.572 / -138.083
3.000GHz	0.575 / 168.953	1.360 / 36.216	0.138 / 38.820	0.595 / -142.485

at $V_{CE} = 3\text{ V}$, $I_C = 5\text{ mA}$

freq	S(1,1)	S(2,1)	S(1,2)	S(2,2)
400.0MHz	0.665 / -94.921	9.834 / 117.507	0.082 / 41.146	0.632 / -72.047
600.0MHz	0.603 / -117.768	7.335 / 103.535	0.095 / 33.927	0.533 / -89.977
800.0MHz	0.569 / -132.943	5.764 / 93.643	0.100 / 30.709	0.468 / -101.722
1.000GHz	0.551 / -144.187	4.723 / 85.891	0.105 / 31.851	0.443 / -110.846
1.200GHz	0.539 / -152.653	4.004 / 79.467	0.106 / 32.741	0.431 / -116.300
1.400GHz	0.528 / -159.545	3.457 / 73.665	0.108 / 32.451	0.429 / -121.890
1.600GHz	0.529 / -165.370	3.053 / 68.396	0.113 / 34.599	0.429 / -126.204
1.800GHz	0.528 / -170.926	2.729 / 63.488	0.118 / 36.053	0.436 / -129.583
2.000GHz	0.533 / -175.760	2.465 / 58.891	0.122 / 38.337	0.445 / -133.612
2.200GHz	0.531 / 179.299	2.246 / 54.548	0.128 / 39.917	0.457 / -137.164
2.400GHz	0.537 / 174.784	2.058 / 50.412	0.135 / 41.190	0.469 / -140.104
2.600GHz	0.545 / 170.757	1.903 / 46.354	0.143 / 42.818	0.487 / -143.577
2.800GHz	0.550 / 165.261	1.767 / 42.290	0.147 / 43.919	0.503 / -144.389
3.000GHz	0.553 / 161.359	1.641 / 38.913	0.155 / 44.228	0.523 / -148.393

at $V_{CE} = 3\text{ V}$, $I_C = 7\text{ mA}$

freq	S(1,1)	S(2,1)	S(1,2)	S(2,2)
400.0MHz	0.618 / -107.854	11.289 / 112.759	0.071 / 40.152	0.567 / -82.538
600.0MHz	0.575 / -129.081	8.199 / 100.035	0.081 / 34.972	0.473 / -100.372
800.0MHz	0.551 / -143.031	6.368 / 91.149	0.087 / 35.586	0.422 / -111.775
1.000GHz	0.538 / -153.102	5.180 / 84.182	0.092 / 35.869	0.402 / -121.138
1.200GHz	0.529 / -160.600	4.379 / 78.357	0.098 / 38.002	0.397 / -125.466
1.400GHz	0.521 / -166.722	3.778 / 73.080	0.104 / 40.499	0.394 / -130.449
1.600GHz	0.523 / -172.324	3.329 / 68.166	0.111 / 41.038	0.397 / -134.178
1.800GHz	0.523 / -177.253	2.977 / 63.650	0.118 / 42.768	0.404 / -136.877
2.000GHz	0.527 / 178.403	2.687 / 59.392	0.126 / 44.545	0.413 / -140.217
2.200GHz	0.528 / 173.774	2.450 / 55.313	0.132 / 45.341	0.424 / -143.259
2.400GHz	0.529 / 169.658	2.249 / 51.456	0.141 / 46.012	0.438 / -145.869
2.600GHz	0.539 / 165.810	2.079 / 47.604	0.151 / 46.780	0.454 / -148.870
2.800GHz	0.543 / 160.741	1.931 / 43.709	0.160 / 46.546	0.468 / -149.043
3.000GHz	0.544 / 156.871	1.798 / 40.450	0.167 / 47.334	0.490 / -152.712

at $V_{CE} = 3\text{ V}$, $I_C = 10\text{ mA}$

freq	S(1,1)	S(2,1)	S(1,2)	S(2,2)
400.0MHz	0.577 / -122.797	12.874 / 107.249	0.059 / 39.988	0.490 / -95.657
600.0MHz	0.550 / -142.280	9.112 / 96.134	0.068 / 40.568	0.421 / -113.731
800.0MHz	0.539 / -154.162	6.997 / 88.456	0.078 / 42.243	0.382 / -125.162
1.000GHz	0.532 / -162.694	5.664 / 82.338	0.082 / 43.729	0.372 / -133.287
1.200GHz	0.526 / -169.420	4.774 / 77.136	0.092 / 47.545	0.365 / -136.711
1.400GHz	0.519 / -174.593	4.112 / 72.387	0.102 / 48.979	0.367 / -140.557
1.600GHz	0.522 / -179.403	3.624 / 67.985	0.112 / 49.670	0.370 / -143.876
1.800GHz	0.522 / 176.031	3.240 / 63.816	0.120 / 50.348	0.377 / -145.781
2.000GHz	0.526 / 172.144	2.928 / 59.873	0.130 / 50.048	0.386 / -148.579
2.200GHz	0.525 / 167.853	2.669 / 56.125	0.139 / 50.679	0.399 / -151.073
2.400GHz	0.529 / 164.145	2.450 / 52.472	0.149 / 51.221	0.410 / -153.029
2.600GHz	0.536 / 160.620	2.268 / 48.905	0.160 / 50.618	0.426 / -155.421
2.800GHz	0.540 / 155.601	2.108 / 45.127	0.169 / 50.334	0.439 / -155.046
3.000GHz	0.541 / 152.216	1.964 / 42.131	0.178 / 49.930	0.461 / -157.953

THN4201 Series

at $V_{CE} = 3\text{ V}$, $I_C = 15\text{ mA}$

freq	S(1,1)	S(2,1)	S(1,2)	S(2,2)
400.0MHz	0.552 / -137.205	14.107 / 102.560	0.048 / 45.820	0.435 / -109.754
600.0MHz	0.543 / -153.653	9.803 / 92.984	0.060 / 46.513	0.385 / -126.905
800.0MHz	0.537 / -163.485	7.481 / 86.265	0.069 / 50.008	0.359 / -136.920
1.000GHz	0.529 / -170.202	6.038 / 80.831	0.079 / 53.969	0.357 / -143.880
1.200GHz	0.525 / -175.940	5.082 / 76.223	0.090 / 54.874	0.349 / -146.344
1.400GHz	0.521 / 179.289	4.372 / 71.835	0.101 / 55.496	0.355 / -149.685
1.600GHz	0.525 / 174.833	3.852 / 67.768	0.113 / 55.322	0.359 / -152.180
1.800GHz	0.526 / 170.914	3.443 / 63.910	0.123 / 56.111	0.364 / -153.538
2.000GHz	0.529 / 167.200	3.109 / 60.243	0.134 / 55.366	0.373 / -155.892
2.200GHz	0.529 / 163.330	2.837 / 56.727	0.145 / 55.247	0.385 / -158.148
2.400GHz	0.531 / 159.704	2.605 / 53.311	0.157 / 54.353	0.397 / -159.560
2.600GHz	0.539 / 156.307	2.415 / 49.897	0.167 / 53.403	0.410 / -161.211
2.800GHz	0.543 / 151.534	2.246 / 46.313	0.177 / 52.655	0.420 / -160.384
3.000GHz	0.544 / 148.368	2.092 / 43.508	0.189 / 51.678	0.443 / -163.420

at $V_{CE} = 3\text{ V}$, $I_C = 20\text{ mA}$

freq	S(1,1)	S(2,1)	S(1,2)	S(2,2)
400.0MHz	0.547 / -145.042	14.736 / 99.949	0.046 / 53.399	0.409 / -118.660
600.0MHz	0.542 / -159.739	10.155 / 91.245	0.057 / 51.873	0.372 / -134.449
800.0MHz	0.539 / -168.098	7.726 / 85.094	0.066 / 55.947	0.352 / -143.683
1.000GHz	0.533 / -174.786	6.224 / 80.046	0.076 / 56.818	0.351 / -150.164
1.200GHz	0.530 / -179.660	5.235 / 75.679	0.090 / 58.347	0.346 / -152.027
1.400GHz	0.525 / 175.913	4.506 / 71.519	0.101 / 59.222	0.352 / -154.985
1.600GHz	0.529 / 171.902	3.967 / 67.662	0.114 / 58.778	0.354 / -157.013
1.800GHz	0.529 / 168.025	3.547 / 63.960	0.125 / 58.724	0.359 / -157.799
2.000GHz	0.533 / 164.645	3.206 / 60.401	0.136 / 57.835	0.369 / -159.963
2.200GHz	0.533 / 160.766	2.922 / 57.028	0.150 / 56.954	0.381 / -161.950
2.400GHz	0.535 / 157.372	2.684 / 53.711	0.161 / 56.274	0.391 / -163.132
2.600GHz	0.543 / 154.106	2.489 / 50.380	0.173 / 54.577	0.406 / -164.734
2.800GHz	0.546 / 149.277	2.318 / 46.901	0.184 / 53.535	0.412 / -163.809
3.000GHz	0.546 / 146.197	2.161 / 44.175	0.194 / 52.137	0.434 / -166.384

at $V_{CE} = 3\text{ V}$, $I_C = 25\text{ mA}$

freq	S(1,1)	S(2,1)	S(1,2)	S(2,2)
400.0MHz	0.536 / -151.123	15.082 / 98.353	0.037 / 48.101	0.391 / -124.588
600.0MHz	0.541 / -163.733	10.351 / 90.197	0.052 / 56.143	0.363 / -139.423
800.0MHz	0.540 / -171.299	7.863 / 84.360	0.064 / 58.507	0.348 / -147.895
1.000GHz	0.536 / -177.023	6.328 / 79.499	0.078 / 60.439	0.351 / -153.661
1.200GHz	0.534 / 178.090	5.326 / 75.304	0.089 / 60.310	0.347 / -155.461
1.400GHz	0.528 / 173.885	4.580 / 71.321	0.102 / 60.341	0.351 / -157.936
1.600GHz	0.532 / 170.081	4.033 / 67.532	0.115 / 61.070	0.353 / -159.686
1.800GHz	0.533 / 166.470	3.604 / 63.953	0.126 / 60.900	0.359 / -160.469
2.000GHz	0.535 / 163.066	3.259 / 60.478	0.140 / 58.809	0.368 / -162.607
2.200GHz	0.536 / 159.313	2.971 / 57.190	0.151 / 58.053	0.379 / -164.203
2.400GHz	0.539 / 155.938	2.731 / 53.939	0.163 / 57.330	0.388 / -165.433
2.600GHz	0.545 / 152.736	2.533 / 50.668	0.175 / 55.946	0.402 / -166.968
2.800GHz	0.548 / 148.055	2.356 / 47.274	0.187 / 54.338	0.410 / -165.406
3.000GHz	0.549 / 145.058	2.197 / 44.567	0.196 / 53.216	0.433 / -168.040

at $V_{CE} = 3\text{ V}$, $I_C = 30\text{ mA}$

freq	S(1,1)	S(2,1)	S(1,2)	S(2,2)
400.0MHz	0.542 / -155.751	15.345 / 96.895	0.040 / 55.380	0.378 / -130.009
600.0MHz	0.546 / -166.898	10.497 / 89.243	0.052 / 57.196	0.359 / -144.082
800.0MHz	0.543 / -174.003	7.965 / 83.708	0.064 / 58.753	0.345 / -151.682
1.000GHz	0.539 / -179.342	6.406 / 79.055	0.076 / 64.244	0.351 / -157.007
1.200GHz	0.540 / 176.004	5.388 / 74.971	0.091 / 63.090	0.344 / -157.936
1.400GHz	0.534 / 172.266	4.632 / 71.077	0.101 / 63.933	0.350 / -160.500
1.600GHz	0.537 / 168.402	4.080 / 67.417	0.115 / 62.117	0.353 / -162.025
1.800GHz	0.537 / 164.757	3.649 / 63.926	0.129 / 61.620	0.358 / -162.676
2.000GHz	0.540 / 161.800	3.299 / 60.512	0.141 / 60.087	0.366 / -164.709
2.200GHz	0.539 / 157.968	3.007 / 57.249	0.153 / 59.415	0.379 / -166.091
2.400GHz	0.542 / 154.689	2.761 / 54.095	0.166 / 58.069	0.388 / -167.288
2.600GHz	0.548 / 151.498	2.564 / 50.859	0.178 / 56.532	0.401 / -168.630
2.800GHz	0.551 / 146.960	2.384 / 47.496	0.191 / 55.186	0.409 / -167.271
3.000GHz	0.551 / 143.720	2.225 / 44.859	0.199 / 53.828	0.431 / -169.649

THN4201 Series

at $V_{CE} = 2\text{ V}$, $I_C = 3\text{ mA}$

freq	S(1,1)	S(2,1)	S(1,2)	S(2,2)
400.0MHz	0.747 / -76.781	7.239 / 125.048	0.106 / 44.793	0.742 / -57.993
600.0MHz	0.670 / -99.654	5.679 / 109.537	0.119 / 34.390	0.639 / -75.168
800.0MHz	0.620 / -116.299	4.580 / 97.967	0.125 / 27.826	0.568 / -86.979
1.000GHz	0.590 / -128.725	3.805 / 88.895	0.129 / 24.260	0.529 / -96.522
1.200GHz	0.571 / -138.368	3.251 / 81.311	0.127 / 22.495	0.516 / -103.105
1.400GHz	0.557 / -146.458	2.819 / 74.495	0.127 / 21.640	0.506 / -109.667
1.600GHz	0.554 / -153.385	2.495 / 68.495	0.126 / 21.553	0.504 / -114.949
1.800GHz	0.554 / -159.725	2.235 / 62.843	0.125 / 22.843	0.511 / -119.414
2.000GHz	0.555 / -165.097	2.017 / 57.645	0.123 / 24.521	0.519 / -124.238
2.200GHz	0.554 / -170.793	1.839 / 52.783	0.124 / 26.843	0.530 / -128.557
2.400GHz	0.558 / -175.913	1.684 / 48.253	0.126 / 29.457	0.542 / -132.449
2.600GHz	0.570 / 179.306	1.556 / 43.863	0.130 / 32.592	0.558 / -136.557
2.800GHz	0.575 / 173.472	1.440 / 39.365	0.132 / 34.589	0.575 / -138.202
3.000GHz	0.576 / 169.034	1.333 / 35.729	0.137 / 36.978	0.596 / -142.658

at $V_{CE} = 2\text{ V}$, $I_C = 5\text{ mA}$

freq	S(1,1)	S(2,1)	S(1,2)	S(2,2)
400.0MHz	0.669 / -94.639	9.623 / 117.662	0.083 / 41.623	0.640 / -71.640
600.0MHz	0.608 / -117.419	7.188 / 103.612	0.095 / 34.525	0.536 / -89.876
800.0MHz	0.573 / -132.619	5.651 / 93.666	0.101 / 31.348	0.472 / -101.624
1.000GHz	0.553 / -143.823	4.628 / 85.871	0.105 / 29.794	0.445 / -110.993
1.200GHz	0.542 / -152.471	3.929 / 79.396	0.108 / 30.456	0.433 / -116.244
1.400GHz	0.530 / -159.076	3.390 / 73.504	0.110 / 31.837	0.431 / -121.868
1.600GHz	0.532 / -165.250	2.994 / 68.211	0.115 / 33.308	0.433 / -126.369
1.800GHz	0.531 / -170.955	2.677 / 63.254	0.120 / 35.571	0.439 / -129.708
2.000GHz	0.535 / -175.562	2.417 / 58.640	0.123 / 37.224	0.448 / -133.676
2.200GHz	0.535 / 179.506	2.203 / 54.235	0.127 / 38.670	0.461 / -137.187
2.400GHz	0.538 / 174.950	2.021 / 50.095	0.134 / 39.748	0.473 / -140.296
2.600GHz	0.547 / 170.707	1.869 / 46.035	0.142 / 41.375	0.488 / -143.769
2.800GHz	0.550 / 165.287	1.735 / 41.877	0.149 / 42.532	0.505 / -144.655
3.000GHz	0.554 / 161.246	1.612 / 38.531	0.156 / 43.232	0.526 / -148.517

at $V_{CE} = 2\text{ V}$, $I_C = 7\text{ mA}$

freq	S(1,1)	S(2,1)	S(1,2)	S(2,2)
400.0MHz	0.618 / -109.449	11.281 / 112.156	0.078 / 37.950	0.556 / -84.043
600.0MHz	0.575 / -130.905	8.172 / 99.558	0.081 / 36.508	0.469 / -101.900
800.0MHz	0.552 / -144.364	6.337 / 90.786	0.086 / 36.581	0.419 / -113.532
1.000GHz	0.539 / -154.072	5.156 / 83.862	0.093 / 36.536	0.402 / -122.690
1.200GHz	0.531 / -161.749	4.355 / 78.115	0.100 / 38.313	0.393 / -127.027
1.400GHz	0.521 / -167.852	3.755 / 72.813	0.104 / 40.871	0.392 / -131.784
1.600GHz	0.524 / -173.103	3.311 / 68.005	0.112 / 42.835	0.394 / -135.723
1.800GHz	0.525 / -178.123	2.962 / 63.500	0.118 / 43.867	0.401 / -138.053
2.000GHz	0.529 / 177.530	2.674 / 59.227	0.126 / 44.786	0.411 / -141.368
2.200GHz	0.530 / 173.002	2.437 / 55.142	0.134 / 45.300	0.422 / -144.333
2.400GHz	0.532 / 168.878	2.235 / 51.316	0.142 / 46.125	0.437 / -146.984
2.600GHz	0.541 / 165.161	2.072 / 47.473	0.151 / 47.152	0.452 / -149.753
2.800GHz	0.545 / 159.803	1.923 / 43.511	0.161 / 46.342	0.466 / -149.895
3.000GHz	0.548 / 156.308	1.790 / 40.375	0.167 / 46.632	0.490 / -153.505

at $V_{CE} = 2\text{ V}$, $I_C = 10\text{ mA}$

freq	S(1,1)	S(2,1)	S(1,2)	S(2,2)
400.0MHz	0.582 / -123.734	12.715 / 107.026	0.063 / 40.839	0.490 / -97.728
600.0MHz	0.559 / -142.975	8.993 / 95.962	0.070 / 39.611	0.419 / -114.943
800.0MHz	0.543 / -154.744	6.907 / 88.280	0.076 / 41.845	0.381 / -125.624
1.000GHz	0.535 / -163.186	5.595 / 82.148	0.085 / 45.260	0.373 / -133.817
1.200GHz	0.527 / -169.645	4.715 / 76.999	0.092 / 46.451	0.367 / -137.192
1.400GHz	0.523 / -174.907	4.061 / 72.213	0.103 / 48.121	0.369 / -141.352
1.600GHz	0.524 / -179.800	3.577 / 67.791	0.111 / 48.847	0.371 / -144.314
1.800GHz	0.525 / 175.626	3.198 / 63.631	0.119 / 49.873	0.381 / -146.351
2.000GHz	0.530 / 171.811	2.888 / 59.681	0.131 / 50.542	0.386 / -149.343
2.200GHz	0.528 / 167.604	2.634 / 55.878	0.139 / 50.699	0.401 / -151.790
2.400GHz	0.532 / 163.897	2.418 / 52.242	0.149 / 51.053	0.413 / -153.756
2.600GHz	0.539 / 160.191	2.242 / 48.611	0.161 / 49.815	0.426 / -155.876
2.800GHz	0.543 / 155.226	2.083 / 44.893	0.172 / 50.027	0.439 / -155.612
3.000GHz	0.545 / 151.877	1.942 / 41.875	0.178 / 49.068	0.462 / -158.782

THN4201 Series

at $V_{CE} = 2\text{ V}$, $I_C = 15\text{ mA}$

freq	S(1,1)	S(2,1)	S(1,2)	S(2,2)
400.0MHz	0.557 / -138.250	13.928 / 102.281	0.051 / 46.171	0.434 / -111.969
600.0MHz	0.546 / -154.514	9.674 / 92.771	0.060 / 44.885	0.383 / -127.953
800.0MHz	0.542 / -163.976	7.378 / 86.074	0.069 / 49.145	0.360 / -137.988
1.000GHz	0.537 / -170.904	5.952 / 80.671	0.079 / 53.721	0.357 / -144.837
1.200GHz	0.531 / -176.575	5.011 / 76.024	0.090 / 53.198	0.353 / -147.340
1.400GHz	0.529 / 178.465	4.311 / 71.652	0.102 / 55.890	0.356 / -150.642
1.600GHz	0.529 / 174.572	3.797 / 67.604	0.112 / 55.860	0.360 / -152.985
1.800GHz	0.531 / 170.455	3.397 / 63.719	0.124 / 55.518	0.366 / -154.322
2.000GHz	0.534 / 166.922	3.068 / 60.035	0.135 / 55.568	0.375 / -156.735
2.200GHz	0.534 / 162.894	2.799 / 56.475	0.146 / 54.823	0.386 / -158.658
2.400GHz	0.536 / 159.237	2.570 / 53.108	0.158 / 54.444	0.398 / -160.319
2.600GHz	0.543 / 156.271	2.382 / 49.646	0.168 / 53.833	0.412 / -162.008
2.800GHz	0.546 / 151.332	2.216 / 46.058	0.179 / 52.329	0.421 / -160.801
3.000GHz	0.547 / 147.973	2.068 / 43.225	0.189 / 51.209	0.443 / -163.767

at $V_{CE} = 2\text{ V}$, $I_C = 20\text{ mA}$

freq	S(1,1)	S(2,1)	S(1,2)	S(2,2)
400.0MHz	0.551 / -148.251	14.614 / 99.173	0.045 / 48.638	0.398 / -122.031
600.0MHz	0.547 / -161.903	10.052 / 90.713	0.055 / 51.371	0.365 / -136.944
800.0MHz	0.544 / -169.815	7.644 / 84.678	0.066 / 55.234	0.350 / -145.870
1.000GHz	0.543 / -175.894	6.154 / 79.676	0.078 / 57.557	0.350 / -152.184
1.200GHz	0.539 / 179.277	5.179 / 75.356	0.092 / 59.064	0.347 / -153.861
1.400GHz	0.534 / 174.766	4.451 / 71.268	0.102 / 59.143	0.353 / -156.615
1.600GHz	0.536 / 171.052	3.922 / 67.409	0.115 / 59.700	0.355 / -158.385
1.800GHz	0.537 / 167.196	3.507 / 63.719	0.127 / 59.313	0.362 / -159.268
2.000GHz	0.540 / 163.867	3.170 / 60.186	0.139 / 57.667	0.369 / -161.566
2.200GHz	0.540 / 160.019	2.889 / 56.791	0.151 / 57.266	0.382 / -163.174
2.400GHz	0.541 / 156.572	2.655 / 53.519	0.162 / 56.313	0.392 / -164.391
2.600GHz	0.549 / 153.267	2.463 / 50.200	0.175 / 54.754	0.406 / -166.048
2.800GHz	0.550 / 148.867	2.291 / 46.714	0.186 / 53.479	0.413 / -164.575
3.000GHz	0.553 / 145.442	2.138 / 43.982	0.195 / 52.604	0.436 / -167.277

at $V_{CE} = 2\text{ V}$, $I_C = 25\text{ mA}$

freq	S(1,1)	S(2,1)	S(1,2)	S(2,2)
400.0MHz	0.548 / -153.349	14.886 / 97.638	0.040 / 52.157	0.387 / -127.661
600.0MHz	0.548 / -165.263	10.203 / 89.682	0.051 / 56.296	0.361 / -141.816
800.0MHz	0.548 / -172.742	7.746 / 83.950	0.063 / 59.150	0.349 / -149.884
1.000GHz	0.544 / -177.912	6.233 / 79.174	0.075 / 60.957	0.352 / -155.008
1.200GHz	0.542 / 177.012	5.242 / 75.007	0.090 / 61.817	0.348 / -156.882
1.400GHz	0.538 / 173.001	4.509 / 71.020	0.101 / 61.870	0.352 / -159.385
1.600GHz	0.541 / 169.222	3.969 / 67.259	0.116 / 60.374	0.356 / -160.988
1.800GHz	0.542 / 165.601	3.550 / 63.683	0.129 / 61.155	0.360 / -161.867
2.000GHz	0.545 / 162.364	3.207 / 60.241	0.140 / 59.405	0.368 / -163.596
2.200GHz	0.543 / 158.734	2.927 / 56.896	0.152 / 58.512	0.380 / -165.183
2.400GHz	0.545 / 155.362	2.689 / 53.676	0.165 / 57.165	0.390 / -166.342
2.600GHz	0.553 / 152.202	2.494 / 50.403	0.176 / 56.070	0.404 / -167.743
2.800GHz	0.557 / 147.593	2.319 / 47.000	0.189 / 54.941	0.413 / -166.418
3.000GHz	0.556 / 144.445	2.167 / 44.327	0.197 / 53.181	0.434 / -169.062

at $V_{CE} = 2\text{ V}$, $I_C = 30\text{ mA}$

freq	S(1,1)	S(2,1)	S(1,2)	S(2,2)
400.0MHz	0.552 / -157.646	15.067 / 96.238	0.038 / 58.675	0.378 / -132.577
600.0MHz	0.552 / -168.155	10.292 / 88.749	0.050 / 61.815	0.357 / -145.565
800.0MHz	0.554 / -175.025	7.803 / 83.321	0.064 / 61.577	0.345 / -153.502
1.000GHz	0.550 / 179.860	6.277 / 78.679	0.076 / 63.744	0.349 / -158.245
1.200GHz	0.547 / 175.385	5.278 / 74.661	0.090 / 63.343	0.347 / -159.088
1.400GHz	0.543 / 171.315	4.540 / 70.771	0.103 / 63.665	0.353 / -161.741
1.600GHz	0.547 / 167.869	3.997 / 67.088	0.116 / 62.895	0.354 / -163.240
1.800GHz	0.545 / 164.185	3.574 / 63.595	0.130 / 61.146	0.359 / -163.858
2.000GHz	0.551 / 161.194	3.229 / 60.164	0.143 / 60.299	0.368 / -165.636
2.200GHz	0.548 / 157.426	2.947 / 56.867	0.155 / 59.347	0.379 / -166.875
2.400GHz	0.551 / 154.282	2.707 / 53.710	0.166 / 58.188	0.389 / -168.031
2.600GHz	0.558 / 151.097	2.512 / 50.489	0.180 / 56.742	0.402 / -169.505
2.800GHz	0.562 / 146.410	2.338 / 47.136	0.190 / 55.449	0.410 / -167.871
3.000GHz	0.562 / 143.530	2.183 / 44.455	0.200 / 53.581	0.431 / -170.287

THN4201 Series

at $V_{CE} = 1\text{ V}$, $I_C = 3\text{ mA}$

freq	S(1,1)	S(2,1)	S(1,2)	S(2,2)
400.0MHz	0.742 / -79.021	7.235 / 124.057	0.102 / 45.062	0.731 / -59.958
600.0MHz	0.665 / -102.098	5.644 / 108.642	0.121 / 34.499	0.627 / -77.101
800.0MHz	0.617 / -118.342	4.531 / 97.222	0.126 / 27.307	0.554 / -89.284
1.000GHz	0.587 / -130.798	3.766 / 88.226	0.128 / 23.568	0.521 / -98.844
1.200GHz	0.571 / -140.180	3.208 / 80.699	0.130 / 22.290	0.506 / -105.555
1.400GHz	0.557 / -147.975	2.780 / 74.020	0.128 / 20.472	0.499 / -111.704
1.600GHz	0.557 / -154.868	2.462 / 68.019	0.128 / 22.180	0.500 / -117.235
1.800GHz	0.553 / -161.312	2.204 / 62.477	0.128 / 22.771	0.506 / -121.256
2.000GHz	0.558 / -166.706	1.991 / 57.354	0.126 / 24.277	0.512 / -125.997
2.200GHz	0.558 / -172.184	1.815 / 52.513	0.127 / 26.968	0.525 / -130.207
2.400GHz	0.562 / -177.184	1.662 / 48.010	0.127 / 29.300	0.538 / -134.003
2.600GHz	0.570 / 178.198	1.537 / 43.630	0.132 / 32.120	0.553 / -138.020
2.800GHz	0.578 / 172.437	1.422 / 39.220	0.135 / 34.427	0.570 / -139.525
3.000GHz	0.581 / 168.082	1.320 / 35.642	0.138 / 37.104	0.592 / -144.064

at $V_{CE} = 1\text{ V}$, $I_C = 5\text{ mA}$

freq	S(1,1)	S(2,1)	S(1,2)	S(2,2)
400.0MHz	0.657 / -98.271	9.637 / 116.327	0.085 / 37.681	0.618 / -75.059
600.0MHz	0.602 / -120.875	7.142 / 102.549	0.097 / 33.796	0.519 / -93.181
800.0MHz	0.574 / -135.701	5.596 / 92.771	0.101 / 30.731	0.461 / -105.227
1.000GHz	0.554 / -146.767	4.578 / 85.133	0.103 / 30.239	0.440 / -114.706
1.200GHz	0.543 / -154.912	3.879 / 78.803	0.109 / 30.585	0.428 / -119.742
1.400GHz	0.535 / -161.534	3.349 / 73.008	0.111 / 32.864	0.424 / -125.245
1.600GHz	0.537 / -167.373	2.957 / 67.828	0.116 / 34.006	0.425 / -129.428
1.800GHz	0.535 / -172.871	2.646 / 62.968	0.120 / 35.955	0.435 / -132.516
2.000GHz	0.540 / -177.478	2.387 / 58.380	0.125 / 37.909	0.443 / -136.465
2.200GHz	0.541 / 177.677	2.177 / 54.077	0.131 / 38.522	0.455 / -139.820
2.400GHz	0.545 / 173.240	1.997 / 49.987	0.136 / 40.139	0.468 / -142.737
2.600GHz	0.554 / 169.080	1.848 / 46.014	0.145 / 41.819	0.485 / -146.116
2.800GHz	0.558 / 163.880	1.715 / 41.847	0.151 / 43.503	0.500 / -146.780
3.000GHz	0.560 / 160.112	1.595 / 38.530	0.159 / 43.312	0.522 / -150.348

at $V_{CE} = 1\text{ V}$, $I_C = 7\text{ mA}$

freq	S(1,1)	S(2,1)	S(1,2)	S(2,2)
400.0MHz	0.619 / -111.278	11.032 / 111.398	0.075 / 40.844	0.551 / -86.682
600.0MHz	0.577 / -132.645	7.965 / 98.936	0.081 / 36.887	0.466 / -104.789
800.0MHz	0.559 / -146.043	6.165 / 90.263	0.089 / 35.278	0.416 / -116.391
1.000GHz	0.547 / -155.623	5.015 / 83.397	0.093 / 37.448	0.401 / -125.145
1.200GHz	0.539 / -162.822	4.239 / 77.647	0.100 / 39.105	0.391 / -129.463
1.400GHz	0.532 / -169.177	3.650 / 72.425	0.104 / 40.840	0.394 / -134.380
1.600GHz	0.533 / -174.253	3.219 / 67.636	0.113 / 41.715	0.398 / -137.842
1.800GHz	0.533 / -179.127	2.880 / 63.143	0.121 / 43.062	0.404 / -140.381
2.000GHz	0.536 / 176.666	2.602 / 58.905	0.127 / 44.196	0.414 / -143.647
2.200GHz	0.538 / 171.971	2.372 / 54.889	0.136 / 44.623	0.424 / -146.551
2.400GHz	0.541 / 167.952	2.177 / 50.999	0.144 / 45.923	0.438 / -148.935
2.600GHz	0.549 / 164.232	2.017 / 47.225	0.153 / 46.130	0.453 / -151.698
2.800GHz	0.553 / 159.118	1.873 / 43.247	0.161 / 46.158	0.467 / -151.718
3.000GHz	0.555 / 155.587	1.745 / 40.133	0.171 / 46.564	0.491 / -155.184

at $V_{CE} = 1\text{ V}$, $I_C = 10\text{ mA}$

freq	S(1,1)	S(2,1)	S(1,2)	S(2,2)
400.0MHz	0.584 / -125.065	12.270 / 106.602	0.063 / 40.321	0.487 / -99.119
600.0MHz	0.564 / -144.144	8.671 / 95.571	0.072 / 37.911	0.420 / -117.105
800.0MHz	0.552 / -155.671	6.654 / 87.918	0.077 / 41.793	0.386 / -128.156
1.000GHz	0.544 / -164.233	5.386 / 81.780	0.084 / 44.319	0.376 / -136.261
1.200GHz	0.540 / -170.710	4.539 / 76.621	0.096 / 45.870	0.372 / -139.414
1.400GHz	0.533 / -175.826	3.911 / 71.856	0.103 / 47.063	0.373 / -143.584
1.600GHz	0.536 / 179.677	3.447 / 67.434	0.112 / 49.132	0.377 / -146.212
1.800GHz	0.536 / 175.063	3.081 / 63.231	0.122 / 49.774	0.384 / -148.197
2.000GHz	0.539 / 171.358	2.786 / 59.307	0.131 / 49.802	0.394 / -151.017
2.200GHz	0.539 / 167.135	2.539 / 55.499	0.141 / 50.029	0.405 / -153.444
2.400GHz	0.544 / 163.266	2.332 / 51.875	0.151 / 50.399	0.418 / -155.367
2.600GHz	0.550 / 159.703	2.162 / 48.254	0.162 / 50.352	0.432 / -157.449
2.800GHz	0.552 / 154.944	2.011 / 44.470	0.171 / 49.098	0.444 / -156.946
3.000GHz	0.555 / 151.462	1.872 / 41.524	0.181 / 48.981	0.466 / -160.185

THN4201 Series

at $V_{CE} = 1\text{ V}$, $I_C = 15\text{ mA}$

freq	S(1,1)	S(2,1)	S(1,2)	S(2,2)
400.0MHz	0.566 / -141.685	13.435 / 101.210	0.052 / 40.401	0.423 / -116.620
600.0MHz	0.561 / -156.504	9.305 / 91.912	0.061 / 47.663	0.387 / -132.061
800.0MHz	0.554 / -165.847	7.095 / 85.397	0.070 / 49.106	0.363 / -141.888
1.000GHz	0.551 / -172.784	5.718 / 80.042	0.080 / 53.696	0.364 / -148.493
1.200GHz	0.547 / -178.179	4.811 / 75.471	0.091 / 55.292	0.359 / -150.803
1.400GHz	0.542 / 177.314	4.143 / 71.119	0.102 / 55.986	0.364 / -153.520
1.600GHz	0.545 / 173.236	3.649 / 67.099	0.114 / 56.056	0.368 / -155.854
1.800GHz	0.546 / 169.208	3.263 / 63.234	0.125 / 55.399	0.373 / -157.119
2.000GHz	0.549 / 165.738	2.950 / 59.621	0.138 / 55.076	0.381 / -159.554
2.200GHz	0.548 / 161.919	2.690 / 56.048	0.149 / 54.987	0.394 / -161.333
2.400GHz	0.551 / 158.444	2.471 / 52.642	0.159 / 53.892	0.404 / -162.752
2.600GHz	0.559 / 155.055	2.292 / 49.222	0.171 / 53.462	0.417 / -164.416
2.800GHz	0.563 / 150.384	2.133 / 45.655	0.183 / 52.329	0.427 / -163.504
3.000GHz	0.562 / 147.037	1.989 / 42.837	0.191 / 51.711	0.450 / -166.029

at $V_{CE} = 1\text{ V}$, $I_C = 20\text{ mA}$

freq	S(1,1)	S(2,1)	S(1,2)	S(2,2)
400.0MHz	0.564 / -150.781	13.817 / 98.258	0.045 / 50.241	0.403 / -126.197
600.0MHz	0.565 / -163.450	9.492 / 89.973	0.056 / 53.365	0.373 / -140.941
800.0MHz	0.562 / -171.211	7.214 / 84.009	0.064 / 55.553	0.358 / -149.074
1.000GHz	0.561 / -177.037	5.807 / 79.028	0.078 / 56.774	0.361 / -155.055
1.200GHz	0.557 / 177.827	4.889 / 74.718	0.091 / 59.021	0.357 / -156.129
1.400GHz	0.553 / 173.809	4.203 / 70.603	0.104 / 59.872	0.363 / -159.103
1.600GHz	0.555 / 170.064	3.703 / 66.716	0.117 / 58.789	0.367 / -160.817
1.800GHz	0.556 / 166.075	3.311 / 63.087	0.128 / 59.026	0.371 / -161.752
2.000GHz	0.558 / 162.983	2.994 / 59.528	0.141 / 57.533	0.379 / -163.853
2.200GHz	0.558 / 159.288	2.731 / 56.083	0.152 / 57.157	0.390 / -165.316
2.400GHz	0.561 / 155.941	2.509 / 52.786	0.164 / 56.366	0.403 / -166.512
2.600GHz	0.568 / 152.882	2.328 / 49.429	0.177 / 54.467	0.414 / -168.102
2.800GHz	0.573 / 148.260	2.165 / 45.993	0.188 / 53.692	0.423 / -166.711
3.000GHz	0.572 / 144.900	2.023 / 43.243	0.197 / 52.271	0.447 / -169.032

at $V_{CE} = 1\text{ V}$, $I_C = 25\text{ mA}$

freq	S(1,1)	S(2,1)	S(1,2)	S(2,2)
400.0MHz	0.568 / -156.725	13.809 / 96.420	0.041 / 49.251	0.385 / -132.959
600.0MHz	0.576 / -167.520	9.443 / 88.661	0.054 / 57.579	0.370 / -146.353
800.0MHz	0.574 / -174.250	7.170 / 83.022	0.065 / 60.044	0.357 / -153.666
1.000GHz	0.570 / -179.791	5.767 / 78.256	0.079 / 60.496	0.362 / -158.778
1.200GHz	0.570 / 175.531	4.852 / 74.080	0.091 / 62.037	0.360 / -159.934
1.400GHz	0.563 / 171.618	4.173 / 70.113	0.105 / 60.703	0.363 / -162.344
1.600GHz	0.567 / 168.070	3.675 / 66.309	0.115 / 61.229	0.367 / -163.775
1.800GHz	0.567 / 164.508	3.287 / 62.716	0.130 / 60.505	0.372 / -164.666
2.000GHz	0.573 / 161.309	2.973 / 59.202	0.144 / 58.996	0.381 / -166.296
2.200GHz	0.571 / 157.748	2.713 / 55.870	0.155 / 58.439	0.393 / -167.840
2.400GHz	0.572 / 154.369	2.492 / 52.599	0.167 / 57.247	0.403 / -168.757
2.600GHz	0.580 / 151.365	2.314 / 49.293	0.179 / 56.111	0.415 / -170.181
2.800GHz	0.581 / 146.677	2.154 / 45.812	0.192 / 54.240	0.422 / -168.709
3.000GHz	0.580 / 143.846	2.010 / 43.203	0.201 / 53.212	0.443 / -171.058

at $V_{CE} = 1\text{ V}$, $I_C = 30\text{ mA}$

freq	S(1,1)	S(2,1)	S(1,2)	S(2,2)
400.0MHz	0.585 / -160.789	13.410 / 94.754	0.041 / 58.675	0.382 / -139.030
600.0MHz	0.590 / -170.935	9.150 / 87.483	0.051 / 59.753	0.368 / -150.838
800.0MHz	0.592 / -176.937	6.940 / 82.092	0.064 / 61.637	0.359 / -157.756
1.000GHz	0.587 / 177.981	5.581 / 77.481	0.076 / 62.263	0.365 / -162.053
1.200GHz	0.585 / 173.916	4.695 / 73.355	0.092 / 63.735	0.363 / -162.822
1.400GHz	0.582 / 170.039	4.039 / 69.436	0.105 / 63.120	0.367 / -164.958
1.600GHz	0.585 / 166.610	3.558 / 65.644	0.120 / 62.161	0.371 / -166.273
1.800GHz	0.585 / 163.032	3.181 / 62.078	0.133 / 61.948	0.376 / -166.770
2.000GHz	0.586 / 159.975	2.878 / 58.596	0.145 / 60.738	0.383 / -168.202
2.200GHz	0.587 / 156.386	2.629 / 55.277	0.158 / 58.835	0.394 / -169.660
2.400GHz	0.588 / 153.271	2.415 / 52.051	0.169 / 57.608	0.405 / -170.393
2.600GHz	0.595 / 150.368	2.242 / 48.749	0.182 / 56.673	0.417 / -171.851
2.800GHz	0.596 / 145.705	2.089 / 45.330	0.193 / 55.221	0.425 / -170.318
3.000GHz	0.596 / 142.800	1.950 / 42.633	0.203 / 53.379	0.447 / -172.668