

MFR4200

Data Sheet

FlexRay Communication Controllers

MFR4200
Rev. 0
8/2005

freescale.com



MFR4200 Data Sheet

MFR4200
Rev. 0
8/2005



To provide the most up-to-date information, the revision of our documents on the World Wide Web will be the most current. Your printed copy may be an earlier revision. To verify that you have the latest information available, refer to <http://www.freescale.com>

The following revision history table summarizes changes contained in this document. For your convenience, the page number designators have been linked to the appropriate location.

Revision History

Date	Revision Level	Description	Page Number(s)
08/2005	0	Initial release.	N/A



Introduction

Device Overview

MFR4200 FlexRay Communication Controller

Dual Output Voltage Regulator (VREG3V3V2)

Clocks and Reset Generator

Oscillator (OSCV2)

Electrical Characteristics

Package Information

Printed Circuit Board Layout Recommendations

MFR4200 Protocol Implementation Document

Index of Registers



Contents

Section Number	Title	Page
Chapter 1		
Introduction		
1.1	Audience	21
1.2	Additional Reading	21
1.3	Terminology	22
1.4	Part Number Coding	23
Chapter 2		
Device Overview		
2.1	Introduction	25
2.1.1	Features	25
2.1.2	Implementation Details and Constraints	26
2.1.3	Modes of Operation	26
2.1.4	Block Diagram	28
2.1.5	Memory Map	30
2.1.6	Part ID Assignments	31
2.2	Signal Descriptions	31
2.2.1	System Pinout	31
2.2.2	Pin Functions and Signal Properties	32
2.2.3	Detailed Signal Descriptions	36
2.2.4	Power Supply Pins	43
2.3	System Clock Description	44
2.4	Modes of Operation	46
2.4.1	Overview	46
2.4.2	Recommended Pullup/down Resistor Values	46
2.4.3	Host Controller Interfaces	46
2.4.4	External Output Clock	47
2.4.5	MFR4200 Connection to FlexRay Network	49
2.4.6	Power Mode	51
2.5	Resets and Interrupts	51
2.5.1	Overview	51
2.5.2	Resets	51
2.5.3	Interrupt Sources	51

Section Number	Title	Page
Chapter 3		
MFR4200 FlexRay Communication Controller		
3.1	Introduction	53
3.1.1	MFR4200 Features	53
3.1.2	MFR4200 Implementation Parameters and Constraints	54
3.2	Memory Map and Registers	54
3.2.1	Introduction	54
3.2.2	Register Map Summary	55
3.2.3	Register Descriptions	60
3.3	Message Buffer	141
3.3.1	Message Buffer Layout	141
3.3.2	Message Buffer Field Descriptions	143
3.3.3	Message Buffer Slot Status Vector	146
3.3.4	Message ID	149
3.3.5	NMVector Fields	149
3.3.6	Data[0:31] — Data Fields	149
3.4	Message Buffer Control, Configuration, Status and Filtering Register Set	150
3.4.1	Message Buffer Control, Configuration and Status Register	150
3.4.2	Message Buffer Filter Registers	158
3.4.3	Receive FIFO Filters	159
3.5	Message Buffer Handling and Operations	160
3.5.1	Introduction	160
3.5.2	Buffer Map	160
3.5.3	Active Message Buffers	161
3.5.4	Buffer Configuration	166
3.5.5	Buffer Reconfiguration in the Normal State of Operation	172
3.5.6	Message Buffer Operations	173
3.6	Receive FIFO Function	186
3.7	Host Controller Interfaces	189
3.7.1	MFR4200 Asynchronous Memory Interface	189
3.7.2	MFR4200 HCS12 Interface	192
3.8	External 4/10 MHz Output Clock	197
3.9	Communication Controller States	197
3.9.1	Hard Reset State	197
3.9.2	Configuration State	199
3.9.3	Diagnosis Stop State	200
3.9.4	Normal Active State	201
3.9.5	Normal Passive State	201
3.10	Debug Port	202
3.10.1	Debug Port Overview	202
3.10.2	Debug Port Functions	203
3.10.3	Debug Port Function Timing	204

Section Number	Title	Page
----------------	-------	------

Chapter 4 Dual Output Voltage Regulator (VREG3V3V2)

4.1	Introduction	207
4.1.1	Features	207
4.1.2	Modes of Operation	207
4.1.3	Block Diagram	207
4.2	External Signal Description	209
4.2.1	V_{DDR} , V_{SSR} — Regulator Power Input	209
4.2.2	V_{DDA} , V_{SSA} — Regulator Reference Supply	209
4.2.3	V_{DD} , V_{SS} — Regulator Output1 (Core Logic)	210
4.2.4	V_{DDOSC} , V_{SSOSC} — Regulator Output2 (OSC)	210
4.2.5	V_{REGEN} — Optional Regulator Enable	210
4.3	Functional Description	210
4.3.1	REG — Regulator Core	210
4.3.2	Full-performance Mode	210
4.3.3	POR — Power On Reset	211
4.3.4	LVR — Low Voltage Reset	211
4.3.5	CTRL — Regulator Control	211
4.4	Resets	211
4.4.1	Power On Reset	211
4.4.2	Low Voltage Reset	211

Chapter 5 Clocks and Reset Generator

5.1	Introduction	213
5.1.1	Features	213
5.2	Functional Description	214
5.2.1	MFR4200 Pins Relevant to the CRG	214
5.2.2	Reset Generation and CLKOUT Control	214

Chapter 6 Oscillator (OSCV2)

6.1	Introduction	217
6.1.1	Features	217
6.1.2	Modes of Operation	217
6.2	External Signal Description	217
6.2.1	V_{DDOSC} and V_{SSOSC} — OSC Operating Voltage, OSC Ground	217
6.2.2	EXTAL and XTAL — Clock/Crystal Source Pins	217
6.3	Functional Description	218

Section Number	Title	Page
Appendix A		
Electrical Characteristics		
A.1	General	219
A.1.1	Parameter Classification	219
A.1.2	Power Supply	220
A.1.3	Pins	220
A.1.4	Current Injection	221
A.1.5	Absolute Maximum Ratings	221
A.1.6	ESD Protection and Latch-up Immunity	222
A.1.7	Operating Conditions	223
A.1.8	Power Dissipation and Thermal Characteristics	223
A.1.9	I/O Characteristics	226
A.1.10	Supply Currents	228
A.2	Voltage Regulator (VREG)	229
A.2.1	Operating Conditions	229
A.2.2	Chip Power-up and Voltage Drops	230
A.2.3	Output Loads	230
A.3	Reset and Oscillator	231
A.3.1	Startup	231
A.3.2	Oscillator	232
A.4	AMI Interface Timing Diagram	232
A.5	HCS12 Interface Timing Diagram	236

Appendix B
Package Information

B.1	64-pin LQFP package	239
-----	---------------------------	-----

Appendix C
Printed Circuit Board Layout Recommendations

Appendix C
MFR4200 Protocol Implementation Document

C.1	Introduction	245
C.1.1	Purpose	245
C.1.2	Structure	245
C.1.3	References	245
C.2	Overall Protocol State Machine	246
C.3	Coding and Decoding	249
C.3.1	Overview	249
C.3.2	NRZ Coding	249
C.3.3	NRZ Decoding	250

Section Number	Title	Page
	C.3.4 Signal Integrity	250
C.4	Frame Format	250
C.5	Media Access Control	250
C.6	Frame and Symbol Processing	251
C.7	Wakeup, Startup, and Reintegration	251
	C.7.1 Introduction	251
	C.7.2 Cluster Wakeup	251
	C.7.3 Communication Startup and Reintegration	251
C.8	Clock Synchronization	252
	C.8.1 Introduction	252
	C.8.2 Time Representation	252
	C.8.3 Synchronization Process	252
	C.8.4 Clock Startup	252
	C.8.5 Time Measurement	252
	C.8.6 Correction Term Calculation	252
	C.8.7 Clock Correction	253
	C.8.8 Sync Frame Configuration Rules	253
C.9	Controller Host Interface	253
C.10	Device Specific Power Modes	253
C.11	Bus Guardian Schedule Monitoring	253
C.12	System Parameters and Configuration Constraints	254
	C.12.1 System Parameters	254
	C.12.2 Configuration Constraints	254

Appendix D Index of Registers

Section Number**Title****Page**

List of Figures

Figure Number	Title	Page
Figure 1-1.	Order Part Number Coding	23
Figure 2-1.	MFR4200 Block Diagram	29
Figure 2-2.	Pin Assignments for MFR4200 in 64-pin LQFP	32
Figure 2-3.	Pierce Oscillator Connections	42
Figure 2-4.	External Clock Connections	43
Figure 2-5.	Clock Connections	45
Figure 2-6.	CLKOUT Generation During Power-on Reset	47
Figure 2-7.	CLKOUT Generation during Low Voltage Reset	48
Figure 2-8.	CLKOUT Generation During External Hard Reset	49
Figure 2-9.	Example: Connecting a FlexRay Optical/Electrical PHY to the MFR4200	50
Figure 2-10.	Example: Connecting an RS485 PHY to the MFR4200	50
Figure 3-1.	Key to Register Diagrams	61
Figure 3-2.	Module Version Register 0	62
Figure 3-3.	Module Version Register 1	62
Figure 3-4.	Magic Number Register	63
Figure 3-5.	Module Configuration Register 0	64
Figure 3-6.	Module Configuration Register 1	66
Figure 3-7.	Host Interface Pins Drive Strength Register	67
Figure 3-8.	Physical Layer Pins Drive Strength Register	68
Figure 3-9.	Host Interface Pins Pullup/down Enable Register	68
Figure 3-10.	Host Interface Pins Pullup/down Control Register	69
Figure 3-11.	Physical Layer Pins Pullup/down Enable Register	69
Figure 3-12.	Physical Layer Pins Pullup/down Control Register	70
Figure 3-13.	Voltage Regulator Status Register	70
Figure 3-14.	Bit Duration Register	71
Figure 3-15.	Delay Compensation Channel A Register	72
Figure 3-16.	Delay Compensation Channel B Register	72
Figure 3-17.	Cluster Drift Damping Register	73
Figure 3-18.	Maximum Sync Frames Register	73
Figure 3-19.	Nominal Macrotick Length Register	74
Figure 3-20.	Microticks Per Cycle Low Register	74
Figure 3-21.	Microticks Per Cycle High Register	75

Figure Number	Title	Page
Figure 3-22.	Static Slot Length Register	75
Figure 3-23.	Number of Static Slots Register	76
Figure 3-24.	Static Payload Length Register	76
Figure 3-25.	Minislot Length Register	77
Figure 3-26.	Minislot Action Point Offset Register	77
Figure 3-27.	Static Slot Action Point Offset Register	78
Figure 3-28.	Latest Dynamic Transmission Start Register	78
Figure 3-29.	Maximum Payload Length Dynamic Register	79
Figure 3-30.	Symbol Window Configuration Register	79
Figure 3-31.	Network Idle Time Configuration Register	80
Figure 3-32.	Cycle Length Register	80
Figure 3-33.	Maximum Cycle Length Deviation Register	81
Figure 3-34.	External Offset Correction Register	81
Figure 3-35.	External Rate Correction Register	82
Figure 3-36.	External Correction Control Register	82
Figure 3-37.	Maximum Offset Correction Register	83
Figure 3-38.	Maximum Rate Correction Register	84
Figure 3-39.	Coldstart Maximum Register	84
Figure 3-40.	Transmit Start Sequence Length Register	85
Figure 3-41.	Network Management Vector Length Register	85
Figure 3-42.	Sync Frame Register	86
Figure 3-43.	Sync Frame Header Register	86
Figure 3-44.	Bus Guardian Tick Register	87
Figure 3-45.	Delay Counter Register	87
Figure 3-46.	Debug Port Control Register	88
Figure 3-47.	Start of Offset Correction Cycle Time Register	89
Figure 3-48.	Idle Detection Length Register	90
Figure 3-49.	Symbol Window Control Register	90
Figure 3-50.	Wakeup Mechanism Control Register	91
Figure 3-51.	Wakeup Symbol TX Idle Register	91
Figure 3-52.	Wakeup Symbol TX Low Register	92
Figure 3-53.	Listen Timeout With Noise Length Register	92
Figure 3-54.	Protocol State Register	93
Figure 3-55.	Current Cycle Counter Value Register	94
Figure 3-56.	Current Macrotick Counter Value Register	94

Figure Number	Title	Page
Figure 3-57.	Offset Correction Value Register	95
Figure 3-58.	Rate Correction Value Register	95
Figure 3-59.	Global Network Management Vector n Register, n = [0:5]	96
Figure 3-60.	Symbol Window Status Channel A Register	97
Figure 3-61.	Symbol Window Status Channel B Register	98
Figure 3-62.	Bus Guardian Status Register	99
Figure 3-63.	Startup Interrupt Enable Register	100
Figure 3-64.	Maximum Odd Cycles Without Clock Correction Fatal Register	101
Figure 3-65.	Maximum Odd Cycles Without Clock Correction Passive Register	101
Figure 3-66.	Channel Status Error Counter n Register, n = [0:1]	102
Figure 3-67.	Interrupt Enable Register 0	103
Figure 3-68.	Slot Status Selection n Register, n = [0:3]	103
Figure 3-69.	Slot Status Counter n Register, n = [0:7]	104
Figure 3-70.	Slot Status Counter Condition n Register, n = [0:7]	105
Figure 3-71.	Slot Status Counter Incrementation Register	107
Figure 3-72.	Slot Status Counter Interrupt Mask Register	107
Figure 3-73.	Receive Buffer Interrupt Vector Register	108
Figure 3-74.	Transmit Buffer Interrupt Vector Register	109
Figure 3-75.	CHI Error Register	109
Figure 3-76.	Clock Correction Failed Counter Register	113
Figure 3-77.	Error Handling Level Register	113
Figure 3-78.	Interrupt Status Register 0	114
Figure 3-79.	Startup Interrupt Status Register	118
Figure 3-80.	Slot Status n Register, n = [0:7]	119
Figure 3-81.	Odd Sync Frame ID n Register, n = [0:15]	120
Figure 3-82.	Even Sync Frame ID n Register, n = [0:15]	121
Figure 3-83.	Odd Measurement Channel A n Register, n = [0:15]	121
Figure 3-84.	Odd Measurement Channel B n Register, n = [0:15]	122
Figure 3-85.	Even Measurement Channel A n Register, n = [0:15]	122
Figure 3-86.	Even Measurement Channel B n Register, n = [0:15]	123
Figure 3-87.	Even Measurement Counter Register	124
Figure 3-88.	Odd Measurement Counter Register	124
Figure 3-89.	FIFO Size Register	125
Figure 3-90.	Message Buffer Control, Configuration and Status n Register, n = [0:58]	126
Figure 3-91.	Active Transmit Buffer Frame ID Register	126

Figure Number	Title	Page
Figure 3-92.	Active Transmit Buffer Cycle Counter and Payload Length Register	127
Figure 3-93.	Active Transmit Buffer Header CRC Register	127
Figure 3-94.	Active Transmit Buffer Data n Register, n = [0:15].	128
Figure 3-95.	Active Transmit Buffer Message Buffer Slot Status Vector Register	128
Figure 3-96.	Active Receive Buffer Frame ID Register	129
Figure 3-97.	Active Receive Buffer Cycle Counter and Payload Length Register.	129
Figure 3-98.	Active Receive Buffer Header CRC Register.	130
Figure 3-99.	Active Receive Buffer Data n Register, n = [0:15].	130
Figure 3-100.	Active Receive Buffer Message Buffer Slot Status Vector Register	131
Figure 3-101.	Active FIFO Buffer Frame ID Register	131
Figure 3-102.	Active FIFO Buffer Cycle Counter and Payload Length Register	132
Figure 3-103.	Active FIFO Buffer Header CRC Register.	132
Figure 3-104.	Active FIFO Buffer Data n Register, n = [0:15].	133
Figure 3-105.	Active FIFO Buffer Message Buffer Slot Status Vector Register	133
Figure 3-106.	Sync Frame Acceptance Filter Value Register	134
Figure 3-107.	Sync Frame Acceptance Filter Mask Register	134
Figure 3-108.	Sync Frame Rejection Filter Register.	135
Figure 3-109.	Cycle Counter Filter n Register, n = [0:58]	135
Figure 3-110.	FIFO Acceptance Filter Message ID Value Register	136
Figure 3-111.	FIFO Acceptance Filter Message ID Mask Register	136
Figure 3-112.	FIFO Acceptance/Rejection Filter Channel Register	137
Figure 3-113.	FIFO Rejection Filter Frame ID Value Register	138
Figure 3-114.	FIFO Rejection Filter Frame ID Mask Register	138
Figure 3-115.	Timer Interrupt Configuration Register 0 Cycle Set	139
Figure 3-116.	Timer Interrupt Configuration Register 0 MacroTICK Offset	140
Figure 3-117.	Timer Interrupt Configuration Register 1 Cycle Set	140
Figure 3-118.	Timer Interrupt Configuration Register 1 High	141
Figure 3-119.	Transmit Message Buffer Slot Status Vector	146
Figure 3-120.	Receive and Receive FIFO Message Buffer Slot Status Vector.	147
Figure 3-121.	BUFCSnR of a Receive Message Buffer	150
Figure 3-122.	BUFCSnR of a Transmit Message Single Buffer for the Dynamic Segment.	150
Figure 3-123.	BUFCSnR of a Host Part Transmit Message Buffer of a Double Tx Buffer for the Dynamic Segment	151
Figure 3-124.	BUFCSnR of a Host Part Transmit Message Buffer of a Double Tx Buffer for the Static Segment.	151

Figure Number	Title	Page
Figure 3-125.	BUFCSnR of a Single Transmit Message Buffer for the Static Segment	151
Figure 3-126.	BUFCSnR of a CC Part Transmit Message Buffer of a Double Tx Buffer for Dynamic and Static Segment	152
Figure 3-127.	BUFCSnR of FIFO Buffer	152
Figure 3-128.	CCFnR, Transmit and Receive Message Buffer Filter Registers	158
Figure 3-129.	CCFnR, CC Part Buffer of a Double Transmit Message Buffer Filter Registers.	158
Figure 3-130.	CCFnR, FIFO Buffer Filter Registers.	158
Figure 3-131.	Buffer Control, Configuration, Status/Filtering Register Set for Transmit/Receive Buffers	161
Figure 3-132.	Buffer Control, Configuration, Status/Filtering Register Set for Receive FIFO Buffers	163
Figure 3-133.	Buffer Busy Bit Timing for a Transmit Message Buffer	165
Figure 3-134.	Example of a Buffer Configuration	170
Figure 3-135.	Transition Scheme Between Different Buffer Types Depending on Operational Mode of CC	173
Figure 3-136.	Operations During a Frame Reception	175
Figure 3-137.	Operations with a Single Transmit Message Buffer during an Event Type of Transmission for a Static Segment	180
Figure 3-138.	Double Transmit Message Buffer Structure	181
Figure 3-139.	Doubled Buffer Data Collection with State Driven Transmit Operation	184
Figure 3-140.	Doubled Buffer Data collection with Event Driven Transmit Operation.	185
Figure 3-141.	FIFO Status (Empty, Not Empty, Overrun) — Example of FIFO with Three Message Buffers	187
Figure 3-142.	Connecting MFR4200 to MPC5xx Using the AMI (Example)	190
Figure 3-143.	Connecting MFR4200 to MAC71xx Using the AMI (Example)	191
Figure 3-144.	Connecting MFR4200 to DSP56F83x (Hawk) Using the AMI (Example)	191
Figure 3-145.	FlexRay CC to HCS12 Device Connection with HCS12 EBI Paged Mode Support. . .	193
Figure 3-146.	FlexRay CC to HCS12 Device Connection with HCS12 EBI Unpaged Mode Support	194
Figure 3-147.	HCS12 interface Address Decoding and Internal CS Signal Generation.	195
Figure 3-148.	Timing Diagram of CC State Transition from Configuration State to Normal State. . .	200
Figure 3-149.	Start of Communication Cycle and Start of Offset Correction Functions Timing.	204
Figure 3-150.	Timing for Debug Functions with Three EXTAL or CC_CLK Clock Cycles of High State (Logic “1”)	204
Figure 3-151.	Slot Start in Static Segment Function Timing	205
Figure 4-1.	VREG3V3 Block Diagram	208
Figure 5-1.	Power-on Reset	215
Figure 5-2.	Low Voltage Reset	215
Figure 5-3.	External Reset	216

Figure Number	Title	Page
Figure A-1.	Voltage Regulator — Chip Power-up and Voltage Drops (not scaled)	230
Figure A-2.	AMI Interface Read and Write Timing Diagrams	233
Figure A-3.	AMI Interface Write-after-Read Transactions Timing Diagram	234
Figure A-4.	AMI Interface Read-after-Write Transactions Timing Diagram	234
Figure A-5.	HCS12 Interface Read/write Timing Diagram	236
Figure B-1.	64-pin LQFP Mechanical Dimensions (Case N 840F-02) (Page 1)	239
Figure B-2.	64-pin LQFP Mechanical Dimensions (Case N 840F-02) (Page 2)	240
Figure B-3.	64-pin LQFP Mechanical Dimensions (Case N 840F-02) (Page 3)	241
Figure C-1.	Recommended PCB Layout (64-pin LQFP) for Standard Pierce Oscillator Mode	244
Figure C-1.	Protocol Operation Control (POC) - 1	246
Figure C-2.	Protocol Operation Control (POC) - 2	247
Figure C-3.	POC — Normal Operation	248
Figure C-4.	POC — Passive Operation	249

List of Tables

Table Number	Title	Page
Table 1-1.	Acronyms and Abbreviations	22
Table 1-2.	Notational Conventions.....	22
Table 2-1.	Interface Selection.....	26
Table 2-2.	Clockout Selection	27
Table 2-3.	Bus Driver Type Selection	27
Table 2-4.	Voltage Regulator VDDR Connection	28
Table 2-5.	Device Memory Map	30
Table 2-6.	Assigned Part ID Numbers	31
Table 2-7.	Pin Functions and Signal Properties	33
Table 2-8.	MFR4200 Power and Ground Connection Summary	43
Table 2-9.	Recommended Pullup/down Resistor Values for IF_SEL[0:1] and CLK_S[0:1] Inputs ..	46
Table 3-1.	Register Map Summary.....	55
Table 3-2.	Bus Driver Type Selection	64
Table 3-3.	Encoding of Debug Port Control Fields CNTRL[7:4] and CNTRL[3:0]	88
Table 3-4.	CC State Coding	93
Table 3-5.	Mapping between Receive Message Buffer Payload Bytes and GNMVnR Registers	96
Table 3-6.	Channel Configuration for SSCnR.....	106
Table 3-7.	Error Handling Level Coding	114
Table 3-8.	Mapping between SSSnR and SSnR.....	120
Table 3-9.	FIFO Size	125
Table 3-10.	FIFO Channel Filtering Configuration	137
Table 3-11.	Receive Message Buffer Layout.....	141
Table 3-12.	Receive FIFO Message Buffer Layout	142
Table 3-13.	Transmit Message Buffer Layout	142
Table 3-14.	Mapping between Buffer Layout and Active Receive/Transmit/FIFO Message Buffers.	143
Table 3-15.	Channel Filtering Configuration	156
Table 3-16.	CC Buffer Fields Accessibility	167
Table 3-17.	Double Transmit Message Buffer Data Collection with State Driven Transmit Operation.....	183
Table 3-18.	Double Transmit Message Buffer Data Collection with Event Driven Transmit Operation.....	186
Table 3-19.	FlexRay CC MCU Interface Configuration	189
Table 3-20.	AMI Interface Signals and Pins Description.....	192

Table Number	Title	Page
Table 3-21.	HCS12 Interface Signal and Pin Descriptions	196
Table 3-22.	CLKOUT Frequency Selection.....	197
Table 3-23.	Debug Port Functions Description	203
Table 4-1.	VREG3V3V2 — Signal Properties.....	209
Table 4-2.	VREG3V3V2 — Reset Sources	211
Table 5-1.	MFR4200 Pins Relevant to the CRG	214
Table A-1.	Absolute Maximum Ratings	221
Table A-2.	ESD and Latch-up Test Conditions.....	222
Table A-3.	ESD and Latch-up Protection Characteristics.....	222
Table A-4.	Operating Conditions	223
Table A-5.	Thermal Package Simulation Details	225
Table A-6.	5V I/O Characteristics (VDD5 = 5V)	226
Table A-7.	3.3V I/O Characteristics (VDD5 = 3.3V)	227
Table A-8.	Supply Current Characteristics	228
Table A-9.	Voltage Regulator - Operating Conditions	229
Table A-10.	Voltage Regulator Recommended Capacitive Loads	230
Table A-11.	Startup Characteristics.....	231
Table A-12.	Oscillator Characteristics	232
Table A-13.	AMI Interface AC Switching Characteristics over the Operating Range	235
Table A-14.	HCS12 Interface Timing Parameters	237
Table C-1.	Suggested External Component Values	243

Chapter 1

Introduction

This data sheet provides information on a system that includes the MFR4200 FlexRay Communication Controller Module.

1.1 Audience

This data sheet is intended for application and system hardware developers who wish to develop products for the FlexRay MFR4200. It is assumed that the reader understands FlexRay protocol functionality and microcontroller system design.

1.2 Additional Reading

For additional reading that provides background to, or supplements, the information in this manual:

- [Appendix C, “MFR4200 Protocol Implementation Document”](#)
- For more information about the FlexRay protocol, refer to the following document:
 - FlexRay Communications System Protocol Specification V1.1, FlexRay Consortium, 2004.
- For more information about Philips Bus Guardian and Bus Driver devices, refer to the following documents:
 - FlexRay Electrical Physical Layer Specification, v1.5, FlexRay Consortium, 2004,
 - FlexRay Bus Guardian Preliminary Functional Specification, v1.9, FlexRay Consortium, June 2004.
- For more information about RS485 transceivers:
 - About the MAX3078 transceiver (IDLE state coded as “1”)
<http://pdfserv.maxim-ic.com/en/ds/MAX3070E-MAX3079E.pdf>
 - About the MAX3485 transceiver (IDLE state coded as “0”)
<http://pdfserv.maxim-ic.com/en/ds/MAX3483-MAX3491.pdf>
- For more information about the Power PC interface, refer to the Freescale products section at www.freescale.com.
- For more information about M9HCS12 Family devices and M9HCS12 programming, refer to the Freescale Products section at www.freescale.com.

1.3 Terminology

Table 1-1. Acronyms and Abbreviations

Term	Meaning
AMI	Asynchronous memory interface
BG	Bus guardian
CC	Communication controller (an alternative term for the MFR4200)
ceil	Function ceil(x) returns the nearest integer greater than or equal to x
Cycle length in μ T	The actual length of a cycle in μ T for the ideal controller (± 0 ppm)
EBI	External bus interface
FSS	Frame start sequence
Host	The FlexRay CC host MCU
LSB	Less/least significant bit
MCU	Microcontroller
MSB	More/most significant bit
MT	Macrotick
μ T	Microtick
NIT	Network idle time
PHY	Physical interface
PS	FlexRay Communications System Protocol Specification
PWD	Protocol working document
RX	Reception
TCU	Time control unit
TX	Transmission
TDMA	Time division multiplex access

Table 1-2. Notational Conventions

active-high	Names of signals that are active-high are shown in upper case text, without a '#' symbol at the end. Active-high signals are asserted (active) when they are high and negated when they are low.
active-low	A '#' symbol at the end of a signal name indicates that the signal is active-low. An active-low signal is asserted (active) when it is at the logic low level and is negated when it is at the logic high level.
asserted	A signal that is asserted is in its active logic state. An active-low signal changes from high to low when asserted; an active-high signal changes from low to high when asserted.
negated	A signal that is negated is in its inactive logic state. An active-low signal changes from low to high when negated; an active-high signal changes from high to low when negated.
set	To set a bit means to establish logic level one on the bit.
clear	To clear a bit means to establish logic level zero on the bit.

Table 1-2. Notational Conventions (continued)

0x0F	The prefix "0x" denotes a hexadecimal number.
0b0011	The prefix "0x" denotes a binary number.
x	In certain contexts, such as a signal encoding, this indicates "don't care". For example, if a field is binary encoded 0bx001, the state of the first bit is "don't care".
==	Used in equations, this symbol signifies comparison.

1.4 Part Number Coding

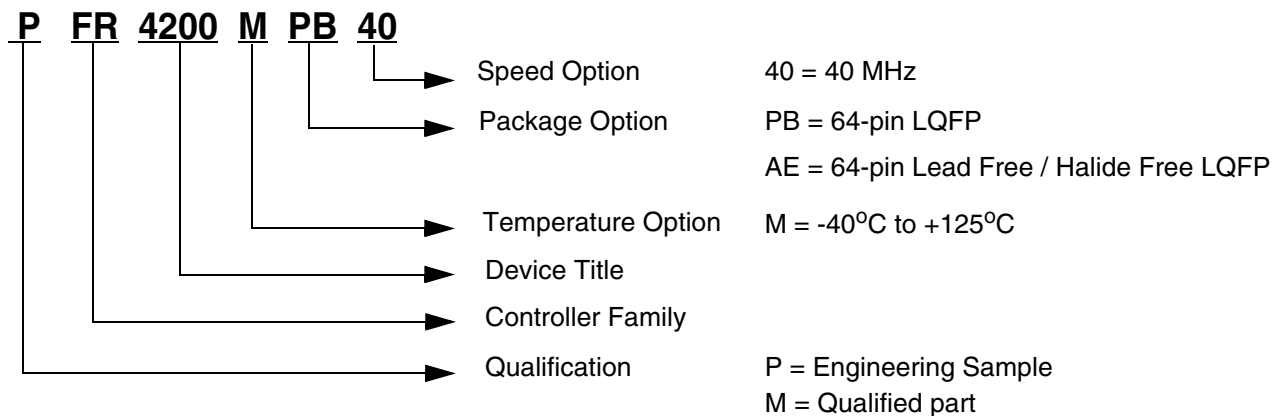

Figure 1-1. Order Part Number Coding

Chapter 2

Device Overview

2.1 Introduction

The FlexRay Communication Controller MFR4200 implements the FlexRay protocol in accordance with [Appendix C, “MFR4200 Protocol Implementation Document”](#). This appendix refers to FlexRay Communications System Protocol Specification V1.1 for most protocol mechanisms, and complements the protocol specification where necessary.

The controller host interface (CHI) of the FlexRay Communication Controller MFR4200 is implemented in accordance with [Chapter 3, “MFR4200 FlexRay Communication Controller”](#).

2.1.1 Features

The following list of features is not comprehensive, but is a selection of the most important features. Detailed descriptions of the protocol and the CHI features are provided in the following.

- [Chapter 3, “MFR4200 FlexRay Communication Controller”](#)
- [Appendix C, “MFR4200 Protocol Implementation Document”](#)

The most important features are:

- Bit rate up to a maximum of 10 Mbit/sec on each of two channels.
- 59 message buffers, each with a payload of up to 32 bytes of data.
- FlexRay frames with up to 254 payload data bytes. Padding is used for FlexRay payload data that exceeds the 32-byte data size boundary.
- One configurable receive FIFO.
- Each message buffer configurable as a receive message buffer, or as a transmit message buffer (single or double), or as part of the receive FIFO.
- Two receive shadow message buffers available to each channel.
- Message buffer configurable with state or event semantics.
- Flexible error signaling mechanism providing eight configurable counters, slot status indicators and interrupts.
- Internal measured time difference values used for clock synchronization can be read via the CHI.
- The status of up to four slots can be observed independently of the communication controller receive buffers.
- The host accesses all message buffers by means of three active message buffers (active transmit message buffer, active message receive buffer, and active receive FIFO buffer) in the CHI.
- Configurable message filtering based on frame ID, cycle counter, and channel, for transmit and receive message buffers.
- Configurable message filtering based on frame ID, channel, and message ID, for the receive FIFO.
- Duration of the communication cycle configurable in microticks.

2.1.2 Implementation Details and Constraints

- The MFR4200 provides two hardware selectable host interfaces:
 - HCS12 interface, for direct connection to Freescale’s HCS12 family of microcontrollers. The HCS12 interface clock signal used to synchronize data transfer can run at a maximum rate of 8 MHz.
 - Asynchronous memory interface (AMI), for asynchronous connection to microcontrollers.
- Internal 40 MHz quartz oscillator.
- Internal voltage regulator for the digital logic and the oscillator.
- Hardware selectable clock output to drive external host devices: Disabled/4/10/40 MHz.
- Maskable interrupt sources available over one interrupt output line.
- Glueless electrical physical layer interface compatible with dedicated FlexRay physical layer. Industry standard RS485 physical layer device can be used with additional glue logic.
- Two pins have multiplexed strobe functions.

NOTE

Refer to [Chapter 3, “MFR4200 FlexRay Communication Controller”](#) for more implementation details and constraints.

2.1.3 Modes of Operation

NOTE

This section depicts only the MFR4200 device modes, not the FlexRay protocol operating modes of the MFR4200 FlexRay module. Refer to [Chapter 3, “MFR4200 FlexRay Communication Controller”](#) for more information on the FlexRay module operating modes.

Only one user mode is available on the MFR4200 — normal operating mode.

In normal operating mode, the selections described below are possible.

2.1.3.1 Interface Selection

The external interface is selected by means of the IF_SEL[0:1] pins, as shown in [Table 2-1](#).

Table 2-1. Interface Selection

Pin		Interface
IF_SEL0	IF_SEL1	
0	0	Reserved
0	1	HCS12 synchronous interface
1	0	Asynchronous Memory Interface
1	1	Reserved

NOTE

As the IF_SEL[0:1] signals share pins with physical layer interface signals, the interface type must be selected using either pullup or pulldown resistors.

IF_SEL[0:1] signals are inputs during the internal reset sequence and are latched by the internal reset signal level. Refer to [Chapter 5, “Clocks and Reset Generator”](#) for more information.

2.1.3.2 Clockout Selection

The CLK_S[0:1] pins select the CLKOUT pin output clock frequency or disable the output clock.

Table 2-2. Clockout Selection

Pin		CLKOUT Function
CLK_S0	CLK_S1	
0	0	4 MHz output
1	0	10 MHz output
0	1	40 MHz output
1	1	Disabled (CLKOUT output is “0”)

NOTE

As CLK_S[0:1] signals share pins with physical layer interface signals, the CLKOUT function must be selected using either pullup or pulldown resistors.

CLK_S[0:1] signals are inputs during the internal reset sequence and are latched by the internal reset signal level. Refer to [Chapter 5, “Clocks and Reset Generator”](#) for more information.

2.1.3.3 Bus Driver Type Selection

The SCM[0:1] bits of the MCR0 register (see [Chapter 3, “MFR4200 FlexRay Communication Controller”](#)) select the bus driver type.

Table 2-3. Bus Driver Type Selection

Driver Type	SCM1	SCM0
RS485 (IDLE state coded as '0') ¹	0	0
Optical/Electrical PHY	0	1
Reserved	1	0
RS485 (IDLE state coded as '1') ¹	1	1

¹ Refer to [Section 1.2, “Additional Reading”](#) for more information on RS485.

NOTE

It is not possible to mix in a cluster or per channel:

- Different RS485;
- RS485 and Optical/Electrical PHY.

2.1.3.4 Internal VREG Enable/Disable Selection**Table 2-4. Voltage Regulator VDDR Connection**

VDDR	Description
Supplied with V_{DD5} ¹	Internal Voltage Regulator enabled
Tied to ground	Internal Voltage Regulator disabled

¹ Refer to [Section A.1.7, "Operating Conditions"](#) for the V_{DD5}

2.1.4 Block Diagram

[Figure 2-1](#) shows a block diagram of the MFR4200 device.

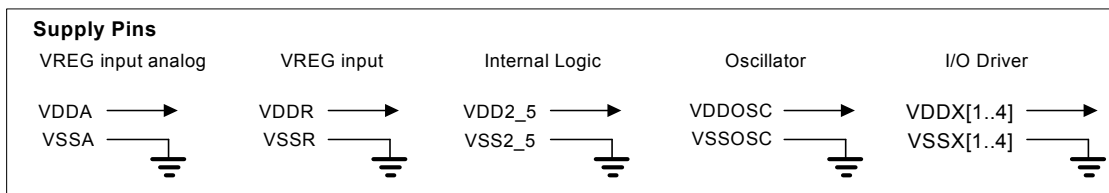
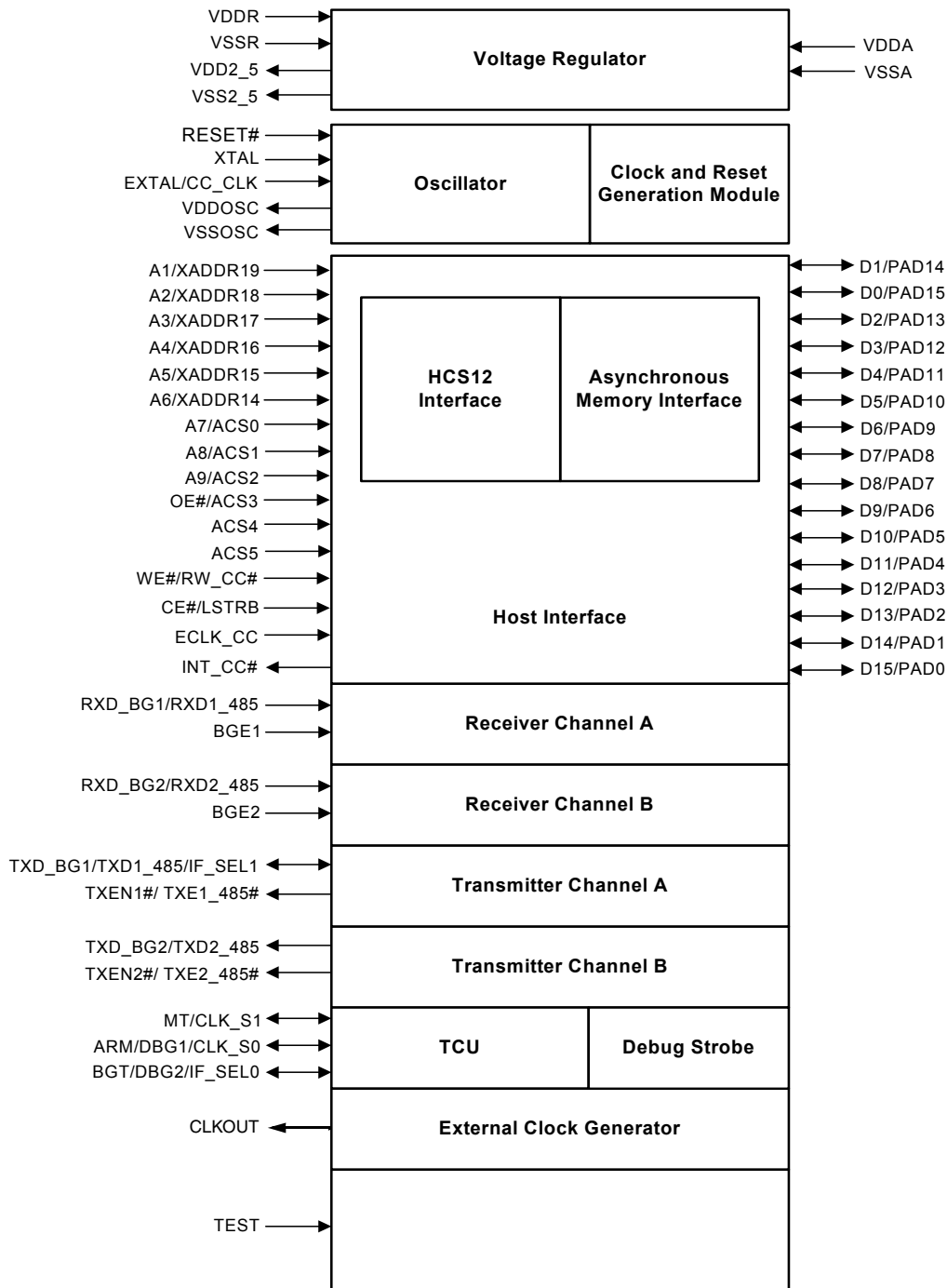

Figure 2-1. MFR4200 Block Diagram

2.1.5 Memory Map

Table 2-5 shows the device memory map of the MFR4200 after a hard reset.

Table 2-5. Device Memory Map

Address (Hex)	Module	Size (bytes)
0x000–0x018	General Control Registers	26
0x01A–0x01E	Acceptance Filter Registers	6
0x024–0x04A	General Control Registers	40
0x04C–0x082	Slot Status Registers	56
0x084–0x0FE	General Control Registers	124
0x100–0x126	Active Receive FIFO Buffer	40
0x128–0x13E	Reserved, read-only location	24
0x140–0x166	Active Receive Message Buffer	40
0x168–0x17E	Reserved, read-only location	24
0x180–0x1A6	Active Transmit Message Buffer	40
0x1A8–0x1FE	Reserved, read-only location	88
0x200–0x2FE	Buffer Control, Configuration and Status Registers, Cycle Counter Filters Registers	256
0x300–0x31E	Reserved, read-only location	32
0x320–0x3FE	General Status Registers	224

The FlexRay block defines the MFR4200 address memory map. Refer to [Chapter 3, “MFR4200 FlexRay Communication Controller](#) for the detailed register map.

2.1.6 Part ID Assignments

The part ID is located in two 16-bit registers, MVR0 and MVR1, at addresses 0x002 and 0x098 (see [Chapter 3, “MFR4200 FlexRay Communication Controller”](#)). This read-only value is a unique part ID for each revision of the chip. [Table 2-6](#) shows the assigned part ID number.

Table 2-6. Assigned Part ID Numbers

Device	Mask Set Number	Part ID ¹	
		MVR0	MVR1
MFR4200	0L60X	0x9042	0x0000
MFR4200	1L60X	0x9042	0x0001

¹ The coding is as follows (see also the MVR0 and MVR1 register descriptions in [Chapter 3, “MFR4200 FlexRay Communication Controller”](#)):

MVR0:

Bit 15-12: Major release of the FlexRay block in the MFR4200 device

Bit 11-08: Minor release of the FlexRay block in the MFR4200 device

Bit 07-00: Device Part ID1

MVR1:

Bit 15-08: Device Part ID2.

Bit 07-04: Major release of the MFR4200 device.

Bit 03-00: Minor release of the MFR4200 device.

2.2 Signal Descriptions

This section describes the signals that connect off-chip. It includes a pinout diagram, a table of signal properties, and a detailed discussion of each signal.

2.2.1 System Pinout

The MFR4200 is available in a 64-pin low profile quad flat package (LQFP). Most pins perform two or more functions, as described in [Section 2.2.2, “Pin Functions and Signal Properties”](#). [Figure 2-2](#) shows the pin assignments.

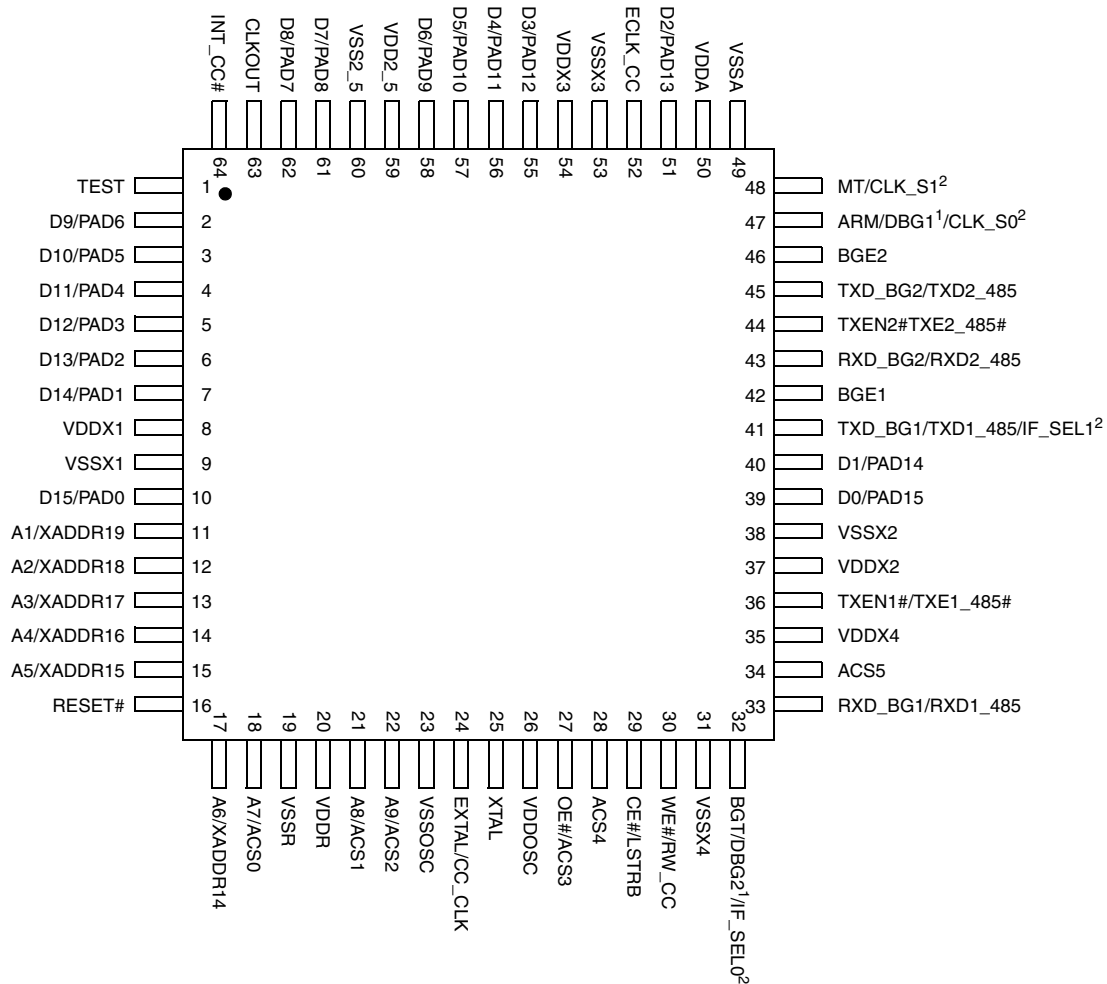

Notes:

- ¹ One of the following internal signals can be output through the DBG1 or DBG2 pin: PCS, SSS, RAGFB, MSS, DSSB, SFB, RCFB, SCC, RAGFA, MTS, SOC, DSSA, SFA, RCFA. (See [Table 3-3](#) and [Table 3-23](#).)
- ² CLK_S[1:0] and IF_SEL[1:0] are inputs during the internal reset sequence, and are latched by the internal reset signal level.

Figure 2-2. Pin Assignments for MFR4200 in 64-pin LQFP

2.2.2 Pin Functions and Signal Properties

Table 2-7 provides a summary of all pin functions and signal properties shown in [Figure 2-2](#).

Table 2-7. Pin Functions and Signal Properties

Pin N	Pin ¹ Function1	Pin ¹ Function2	Pin ¹ Function3	Powered by	In/ Out	Pin type ^{2,3}	Re set	Functional Description
Host Interface Pins								
11	A1	XADDR19	-	VDDX	I	PC	-	AMI address bus / HCS12 expanded address lines. A1= LSB of the AMI address bus.
12	A2	XADDR18	-	VDDX	I	PC	-	AMI address bus / HCS12 expanded address lines.
13	A3	XADDR17	-	VDDX	I	PC	-	AMI address bus / HCS12 expanded address lines.
14	A4	XADDR16	-	VDDX	I	PC	-	AMI address bus / HCS12 expanded address lines.
15	A5	XADDR15	-	VDDX	I	PC	-	AMI address bus / HCS12 expanded address lines.
17	A6	XADDR14	-	VDDX	I	PC	-	AMI address bus / HCS12 expanded address lines. XADDR14 = LSB of the HCS12 expanded address lines
18	A7	ACS0	-	VDDX	I	PC	-	AMI address bus / HCS12 address select inputs.
21	A8	ACS1	-	VDDX	I	PC	-	AMI address bus / HCS12 address select inputs.
22	A9	ACS2	-	VDDX	I	PC	-	AMI address bus / HCS12 address select inputs.
27	OE# ⁴	ACS3	-	VDDX	I	PC	-	AMI read output enable signal / HCS12 address select input.
28	ACS4	-	-	VDDX	I	PC	-	HCS12 address select inputs.
34	ACS5	-	-	VDDX	I	PC	-	HCS12 address select inputs. MSB of the address select inputs.
10	D15	PAD0	-	VDDX	I/O	Z/DC/PC	Z	AMI data bus / HCS12 multiplexed address/data bus. PAD0 is the LSB of the HCS12 address/data bus.
7	D14	PAD1	-	VDDX	I/O	Z/DC/PC	Z	AMI data bus / HCS12 multiplexed address/data bus.
6	D13	PAD2	-	VDDX	I/O	Z/DC/PC	Z	AMI data bus / HCS12 multiplexed address/data bus.
5	D12	PAD3	-	VDDX	I/O	Z/DC/PC	Z	AMI data bus / HCS12 multiplexed address/data bus.
4	D11	PAD4	-	VDDX	I/O	Z/DC/PC	Z	AMI data bus / HCS12 multiplexed address/data bus.
3	D10	PAD5	-	VDDX	I/O	Z/DC/PC	Z	AMI data bus / HCS12 multiplexed address/data bus.
2	D9	PAD6	-	VDDX	I/O	Z/DC/PC	Z	AMI data bus / HCS12 multiplexed address/data bus.

Table 2-7. Pin Functions and Signal Properties (continued)

Pin N	Pin ¹ Function1	Pin ¹ Function2	Pin ¹ Function3	Powered by	In/ Out	Pin type ^{2,3}	Re set	Functional Description
62	D8	PAD7	-	VDDX	I/O	Z/DC/PC	Z	AMI data bus / HCS12 multiplexed address/data bus.
61	D7	PAD8	-	VDDX	I/O	Z/DC/PC	Z	AMI data bus / HCS12 multiplexed address/data bus.
58	D6	PAD9	-	VDDX	I/O	Z/DC/PC	Z	AMI data bus / HCS12 multiplexed address/data bus.
57	D5	PAD10	-	VDDX	I/O	Z/DC/PC	Z	AMI data bus / HCS12 multiplexed address/data bus.
56	D4	PAD11	-	VDDX	I/O	Z/DC/PC	Z	AMI data bus / HCS12 multiplexed address/data bus.
55	D3	PAD12	-	VDDX	I/O	Z/DC/PC	Z	AMI data bus / HCS12 multiplexed address/data bus.
51	D2	PAD13	-	VDDX	I/O	Z/DC/PC	Z	AMI data bus / HCS12 multiplexed address/data bus.
40	D1	PAD14	-	VDDX	I/O	Z/DC/PC	Z	AMI data bus / HCS12 multiplexed address/data bus.
39	D0	PAD15	-	VDDX	I/O	Z/DC/PC	Z	AMI data bus / HCS12 multiplexed address/data bus. D0 is the LSB of the AMI data bus
29	CE#	LSTRB	-	VDDX	I	PC	-	AMI chip select signal / HCS12 low-byte strobe signal
30	WE#	RW_CC#	-	VDDX	I	PC	-	AMI write enable signal/ HCS12 read/write select signal
52	ECLK_CC	-	-	VDDX	I	PC	-	HCS12 clock input
Physical Layer Interface								
32	BGT	DBG2	IF_SEL0	VDDX	I/O	DC/PD	-	Bus Guardian Tick / Debug strobe point signal 2/Host interface selection 0
48	MT	CLK_S1	-	VDDX	I/O	DC/PD	-	Bus Guardian Macrotick/Controller clock output select signal 1
47	ARM	DBG1	CLK_S0	VDDX	I/O	DC/PD	-	Bus Guardian ARM signal / Debug strobe point signal1/Controller clock output select signal 0
33	RXD_BG1	RXD2_485	-	VDDX	I	PC	-	PHY Data receiver input / RS485 Data receiver input
43	RXD_BG2	RXD2_485	-	VDDX	I	PC	-	PHY Data receiver input / RS485 Data receiver input
36	TXEN1#	TXE1_485#	-	VDDX	O	DC	1	Transmit enable for PHY / Transmit enable for RS485
44	TXEN2#	TXE2_485#	-	VDDX	O	DC	1	Transmit enable for PHY / Transmit enable for RS485

Table 2-7. Pin Functions and Signal Properties (continued)

Pin N	Pin ¹ Function1	Pin ¹ Function2	Pin ¹ Function3	Powered by	In/ Out	Pin type ^{2,3}	Re set	Functional Description
41	TXD_BG1	TXD1_485	IF_SEL1	VDDX	I/O	DC/PD	-	PHY Data transmitter output / RS485 Data transmitter output / Host interface selection 1
45	TXD_BG2	TXD2_485	-	VDDX	O	DC	0	PHY Data transmitter output / RS485 Data transmitter output
42	BGEN1	-	-	VDDX	I	PC	-	Bus Guardian Enable monitor input
46	BGEN2	-	-	VDDX	I	PC	-	Bus Guardian Enable monitor input
Clock Signals								
63	CLKOUT	-	-	VDDX	I/O	DC	-	Controller clock output selectable as disabled or 4/10/40 MHz
Others								
16	RESET#	-	-	VDDX	I	-	-	Hardware reset input
64	INT_CC#	-	-	VDDX	O	OD/DC	1	Controller interrupt output
1	TEST	-	-	VDDX	I	-	-	Must be tied to logic low in application.
Oscillator								
24	EXTAL	CC_CLK	-	VDDOSC	I	-	-	Crystal driver / External clock pin
25	XTAL	-	-		I	-	-	Crystal driver pin
Supply/Bypass Filter pins								
8	VDDX1	-	-	-	-	-	-	Supply voltage, I/O
37	VDDX2	-	-	-	-	-	-	Supply voltage, I/O
54	VDDX3	-	-	-	-	-	-	Supply voltage, I/O
35	VDDX4	-	-	-	-	-	-	Supply voltage, I/O
9	VSSX1	-	-	-	-	-	-	Supply voltage ground, I/O
38	VSSX2	-	-	-	-	-	-	Supply voltage ground, I/O
53	VSSX3	-	-	-	-	-	-	Supply voltage ground, I/O
31	VSSX4	-	-	-	-	-	-	Supply voltage ground, I/O
20	VDDR	-	-	-	-	-	-	Supply voltage, supply to pin drivers and internal voltage regulator
19	VSSR	-	-	-	-	-	-	Supply voltage ground, ground to pin drivers and internal voltage regulator
50	VDDA	-	-	-	-	-	-	Supply analog voltage
49	VSSA	-	-	-	-	-	-	Supply analog voltage ground
59	VDD2_5 ⁴	-	-	-	-	-	-	Core voltage power supply output (nominally 2.5V)
60	VSS2_5 ⁴	-	-	-	-	-	-	Core voltage ground output

Table 2-7. Pin Functions and Signal Properties (continued)

Pin N	Pin ¹ Function1	Pin ¹ Function2	Pin ¹ Function3	Powered by	In/Out	Pin type ^{2,3}	Reset	Functional Description
26	VDDOSC ⁴	-	-	-	-	-	-	Oscillator voltage power supply output (nominally 2.5 V)
23	VSSOSC ⁴	-	-	-	-	-	-	Oscillator voltage ground output

¹ # – signal is active-low.

² PC (Pullup/down Controlled) – Register controlled internal weak pullup/down for a pin in input mode. Refer to the following sections for more information:

- Section 3.2.3.2.5, “Host Interface Pins Pullup/down Enable Register (HIPPER)”
- Section 3.2.3.2.6, “Host Interface Pins Pullup/down Control Register (HIPPCR)”
- Section 3.2.3.2.7, “Physical Layer Pins Pullup/down Enable Register (PLPPER)”
- Section 3.2.3.2.8, “Physical Layer Pins Pullup/down Control Register (PLPPCR)”

PD (Pull Down) – Internal weak pulldown for a pin in input mode.

DC (Drive strength Controlled) – Register controlled drive strength for a pin in the output mode. Refer to the following for more information:

- Section 3.2.3.2.3, “Host Interface and Physical Layer Pins Drive Strength Register (HIPDSR)”
- Section 3.2.3.2.4, “Physical Layer Pins Drive Strength Register (PLPDSR)”

Z – Three-stated pin.

OD (Open Drain) – Output pin with open drain.

³ Reset state:

- All pins with the PC option have pullup/down resistors disabled.
- All pins with the DC option have full drive strength.

⁴ No load allowed except for bypass capacitors.

2.2.3 Detailed Signal Descriptions

2.2.3.1 A[1:6]/XADDR[19:14] — AMI Address Bus, HCS12 Expanded Address Inputs

A[1:6]/XADDR[19:14] are general purpose input pins. Their function is selected by the IF_SEL[0:1] pins. Refer to Section 3.7, “Host Controller Interfaces” for more information. The pins can be configured to enable or disable either pullup or pulldown resistors on the pins. (See Section 3.2.3.2.5, “Host Interface Pins Pullup/down Enable Register (HIPPER)” and Section 3.2.3.2.6, “Host Interface Pins Pullup/down Control Register (HIPPCR)”.)

A[1:6] are AMI interface address signals. A1 is the LSB of the AMI address bus.

XADDR[19:14] are HCS12 interface expanded address lines. XADDR14 is the LSB of the HCS12 interface expanded address lines.

2.2.3.2 A[7:9]/ACS[0:2] — AMI Address Bus, HCS12 Expanded Address Inputs

A[7:9]/ACS[0:2] are general purpose input pins. Their function is selected by the IF_SEL[0:1] pins. Refer to Section 3.7, “Host Controller Interfaces” for more information. The pins can be configured to enable or disable either pullup or pulldown resistors on the pins.

A[7:9] are AMI interface address signals.

ACS[0:2] are HCS12 interface address select signals.

2.2.3.3 OE#/ACS3 — AMI Read Output Enable, HCS12 Address Select Input.

OE#/ACS3 is a general purpose input pin. Its function is selected by the IF_SEL[0:1] pins. Refer to [Section 3.7, “Host Controller Interfaces”](#) for more information. The pin can be configured to enable or disable either a pullup or pulldown resistor on the pin.

OE# is the AMI interface output enable signal. This signal controls MFR4200 data output and the state of three-stated data pins D[15:0] during host read operations.

ACS3 is an HCS12 interface address select signal.

2.2.3.4 ACS[4:5] — HCS12 Address Select Inputs

ACS[4:5] are general purpose input pins. Their function is selected by the IF_SEL[0:1] pins. Refer to [Section 3.7, “Host Controller Interfaces”](#) for more information. The pins can be configured to enable or disable either pullup or pulldown resistors on the pins.

ACS[4:5] are HCS12 interface address select signals. ACS5 is the MSB of the address select inputs.

2.2.3.5 D[15:0]/PAD[0:15] — AMI Data Bus, HCS12 Multiplexed Address/Data Bus

D[15:0]/PAD[0:15] are general purpose input or output pins. Their functions are selected by the IF_SEL[0:1] pins. Refer to [Section 3.7, “Host Controller Interfaces”](#) for more information. These pins can be configured to provide either high or reduced output drive, and also to enable or disable either pullup or pulldown resistors on the pins.

D[15:0] are data signals of the AMI interface. D0 is the LSB of the AMI data bus.

PAD[0:15] are HCS12 interface multiplexed address/data signals in the HCS12 Host interface mode of operation. PAD0 is the LSB of the HCS12 address/data bus.

2.2.3.6 CE#/LSTRB — AMI Chip Select, HCS12 Low-byte Strobe

The function of this pin is selected by IF_SEL[0:1] pins. [Section 3.7, “Host Controller Interfaces”](#) for more information. The pin can be configured to enable or disable either a pullup or pulldown resistor on the pin.

CE# is an AMI interface transfer size input signal. It indicates the size of the requested data transfer in the current bus cycle.

LSTRB is an HCS12 interface low-byte strobe input signal. It indicates the type of bus access.

2.2.3.7 WE#/RW_CC# — AMI Write Enable, HCS12 Read/Write Select

The function of this pin is selected by IF_SEL[0:1] pins. Refer to [Section 3.7, “Host Controller Interfaces”](#) for more information. The pin can be configured to enable or disable either a pullup or pulldown resistor on the pin.

WE# is an AMI interface write select signal. It strobes the valid data provided by the host on the D[15:0] pins during write operations to the MFR4200 memory.

RW_CC# is an HCS12 interface read/write input signal. It indicates the direction of data transfer for a transaction.

2.2.3.8 ECLK_CC — HCS12 Clock Input

ECLK_CC is the HCS12 interface clock input signal. The input clock frequency can be up to 8 MHz in the HCS12 mode of the external interface block. The pin can be configured to enable or disable either a pullup or pulldown resistor on the pin.

2.2.3.9 BGT/DBG2/IF_SEL0 — Bus Guardian Tick, Debug Strobe Point 2, Host Interface Selection 0

BGT is a bus guardian tick clock output signal provided from the CC. If a Bus Guardian device is not used in an application, this pin may be left open.

BGT is active, irrespective of which physical layer is selected. If the RS485 Driver type is selected, this pin is not used.

This signal should be connected to the bus guardian on each channel. The pin can be configured to provide either high or reduced output drive.

DBG2 is debug strobe point output 2. The function output on this pin is selected by the debug port control register. Refer to [Section 3.10, “Debug Port”](#) for more information.

IF_SEL0 is the CC external interface selection input signal. Refer to [Table 2-1](#) for the selection coding.

NOTE

The IF_SEL[0:1] signals are inputs during the internal reset sequence and are latched by the internal reset signal level.

While the IF_SEL0 value is being latched, the output drive control is disabled and the internal pulldown resistor is connected to the pin.

As the IF_SEL[0:1] signals share pins with Physical Layer Interface signals, pullup/down devices must be used for selection. Recommended pullup/down resistor values for the IF_SEL[0:1] inputs are given in [Section 2.4.2, “Recommended Pullup/down Resistor Values”](#).

2.2.3.10 MT/CLK_S1 — Bus Guardian Macrotick, Clock Output Select 1

MT is a Bus Guardian macrotick output signal from the CC. If a bus guardian device is not used in an application, this pin may be left open.

MT is active, irrespective of which physical layer is selected. If the RS485 driver type is selected, this pin is not used.

This signal should be connected to the Bus Guardians on each channel. The pin can be configured to provide either high or reduced output drive.

CLK_S1 is the CLKOUT clock frequency selection input signal. See [Table 2-2](#).

NOTE

CLK_S[0:1] signals are inputs during the internal reset sequence and are latched by the internal reset signal level.

While the CLK_S1 value is being latched, the output drive control is disabled and the internal pulldown resistor is connected to the pin.

As CLK_S[0:1] signals share pins with Physical Layer Interface signals, pullup/down devices must be used for the selection. Recommended pullup/down resistor values for the CLK_S[0:1] inputs are given in [Section 2.4.2, “Recommended Pullup/down Resistor Values”](#).

2.2.3.11 ARM/DBG1/CLK_S0 — Bus Guardian ARM, Debug Strobe Point 1, Clock Output Select 0

ARM is an output signal from the CC to a bus guardian. If a bus guardian device is not used in an application, this pin may be left open.

ARM is active, irrespective of which physical layer is selected. If the RS485 driver type is selected, this pin is not used.

This signal should be connected to the bus guardian on each channel. The pin can be configured to provide either high or reduced output drive.

DBG1 is the debug strobe point output 1. The function output on this pin is selected by the debug port control register. Refer to [Section 3.10, “Debug Port”](#) for more information.

CLK_S0 is the CLKOUT clock frequency selection input signal. See [Table 2-2](#).

NOTE

CLK_S[0:1] signals are inputs during the internal reset sequence and are latched by the internal reset signal level.

While the CLK_S0 value is being latched, the output drive control is disabled and the internal pulldown resistor is connected to the pin.

As CLK_S[0:1] signals share pins with Physical Layer Interface signals, pullup/down devices must be used for selection. Recommended pullup/down resistor values for the CLK_S[0:1] inputs are given in the [Section 2.4.2, “Recommended Pullup/down Resistor Values”](#).

2.2.3.12 RXD_BG[1:2]/RXD[1:2]_485 — PHY Received Data, RS485 Received Data

The function of this pin is selected by the SCM[0:1] bits in the MCR0 register. Refer to [Section 3.2.3.2.1, “Module Configuration Register 0 \(MCR0\)”](#) for more information. The pins can be configured to enable or disable either pullup or pulldown resistors on the pins.

RXD_BG[1:2] are bus driver receive data input signals if the FlexRay Optical/Electrical PHY is configured:

- RXD_BG1 is the input to the CC from Physical Layer Channel 1.
- RXD_BG2 is the input to the CC from Physical Layer Channel 2.

RXD[1:2]_485 are bus driver receive data input signals if the RS485 Driver type is configured:

- RXD1_485 is the input to the CC from Physical Layer Channel 1
- RXD2_485 is the input to the CC from Physical Layer Channel 2.

2.2.3.13 TXEN[1:2]#/TXE[1:2]_485# — PHY Transmit Enable, RS485 Transmit Enable

TXEN[1:2]# are bus driver transmit enable output signals if the FlexRay Optical/Electrical PHY is configured:

- TXEN1# is the output of the CC to Physical Layer Channel 1
- TXEN2# is the output of the CC to Physical Layer Channel 2.

TXE[1:2]_485# are Bus Driver Transmit Enable output signals if the RS485 Driver type is configured:

- TXE1_485# is the output of the CC to the Physical Layer Channel 1.
- TXE2_485# is the output of the CC to the Physical Layer Channel 2.

Refer to [Figure 2-10](#) for an example RS485 bus driver connection using external glue logic.

The pins can be configured to provide either high or reduced output drive.

2.2.3.14 TXD_BG1/TXD1_485/ IF_SEL1 — PHY Transmit Data 1, RS485 Transmit Data 1, Host Interface Selection 1

The function of this pin is selected by the SCM[0:1] bits in the MCR0 register. Refer to [Section 3.2.3.2.1, “Module Configuration Register 0 \(MCR0\)”](#) for more information. The pins can be configured to provide either high or reduced output drive.

TXD_BG[1:2] are bus driver transmit data output signals if the FlexRay Optical/Electrical PHY is configured:

- TXD_BG1 is the output of the CC to Physical Layer Channel 1
- TXD_BG2 is the output of the CC to Physical Layer Channel 2.

TXD[1:2]_485 are bus driver transmit data output signals if the RS485 Driver type is configured:

- TXD1_485 is the output of the CC to Physical Layer Channel 1.
- TXD2_485 is the output of the CC to Physical Layer Channel 2.

IF_SEL1 is the CC external interface selection input signal. Refer to [Table 2-1](#) for the selection coding.

NOTE

IF_SEL[0:1] signals are inputs during the internal reset sequence and are latched by the internal reset signal level.

While the IF_SEL1 level is being latched, the output drive control is disabled and the internal pulldown resistor is connected to the pin.

As IF_SEL[0:1] signals share pins with Physical Layer Interface signals, pullup/down devices must be used for the selection. Recommended pullup/down resistor values for the IF_SEL[0:1] inputs are given in [Section 2.4.2, “Recommended Pullup/down Resistor Values”](#).

2.2.3.15 TXD_BG2/TXD2_485 — PHY Transmit Data 2, RS485 Transmit Data 2

The function of this pin is selected by the SCM[0:1] bits in the MCR0 register. Refer to [Section 3.2.3.2.1, “Module Configuration Register 0 \(MCR0\)”](#) for more information.

TXD_BG[1:2] are bus driver transmit data output signals if the FlexRay Optical/Electrical PHY is configured:

- TXD_BG1 is the output of the CC to Physical Layer Channel 1.
- TXD_BG2 is the output of the CC to Physical Layer Channel 2.

TXD[1:2]_485 are bus driver transmit data output signals if the RS485 Driver type is configured:

- TXD1_485 is the output of the CC to the Physical Layer Channel 1.
- TXD2_485 is the output of the CC to the Physical Layer Channel 2.

2.2.3.16 BGEN[1:2] — Bus Guardian Enable

The CC monitors the schedule of Bus Guardians operations by checking the BGEN[1:2] input signals provided by Bus Guardians:

BGEN1 is the input from the Physical Layer Channel 1 to the CC.

BGEN2 is the input from the Physical Layer Channel 2 to the CC.

If the RS485 Driver type is configured, the BGEN[1:2] inputs are not used and may be left open, but it is recommended to connect these pins to the logic "0" or logic "1" level either by enabling either pullup or pulldown resistors or by using external components. The pins can be configured to enable or disable either pullup or pulldown resistors on the pins.

2.2.3.17 CLKOUT — Clock Output

CLKOUT is an external continuous clock output signal. The frequency of CLKOUT is selected by the CLK_S[0:1] pins. The CLKOUT signal is always active after power-up of the CC, in all CC states including the hard reset state. The pin can be configured to provide either high or reduced output drive.

As the CLKOUT signal can be disabled during internal resets, refer to [Section 2.4.4, “External Output Clock”](#) for more information on CLKOUT generation during external hard and internal resets.

2.2.3.18 RESET# — External Reset

RESET# is an active-low control signal that acts as an input to initialize the CC to a known startup state.

2.2.3.19 INT_CC# — Interrupt Output

INT_CC# is an AMI and HCS12 interfaces interrupt request output signal. The CC may request a service routine from the host to run. The interrupt is indicated by the logic level: it is asserted if the INT_CC# outputs a logic "0" and negated if it outputs a logic "1".

The pin can be configured to provide either high or reduced output drive.

2.2.3.20 TEST

The TEST pin must be tied to VSS in all applications.

2.2.3.21 EXTAL/CC_CLK — Crystal Driver, External Clock Pin

This pin can act as a crystal driver pin (EXTAL) or as an external clock input pin (CC_CLK). On reset, the device clock is derived from the input frequency on this pin. Refer to [Figure 2-3](#) for Pierce oscillator connections and [Figure 2-4](#) for external clock connections. See also [Chapter 6, “Oscillator \(OSCV2\)”](#).

2.2.3.22 XTAL — Crystal Driver Pin

XTAL is a crystal driver pin. Refer to [Figure 2-3](#) for Pierce oscillator connections and [Figure 2-4](#) for external clock connections. See also [Chapter 6, “Oscillator \(OSCV2\)”](#).

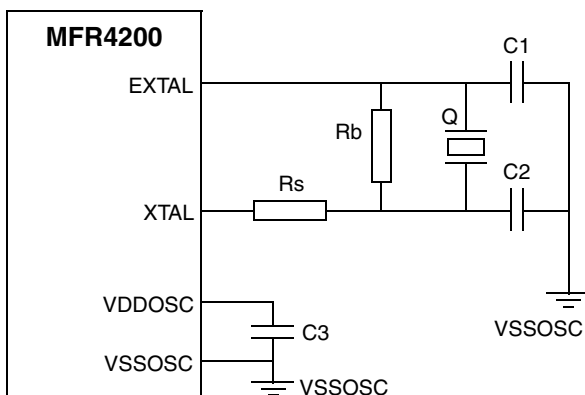

Where:

- Q = 40 MHz crystal
- Rb is in the range 1M - 10 Mohms
- Rs is a lower value, which can be 0 Ohms
- C1 = C2
- Oscillator supply output capacitor C3 = 220 nF

Refer to crystal manufacturer's product specification for recommended values

Figure 2-3. Pierce Oscillator Connections

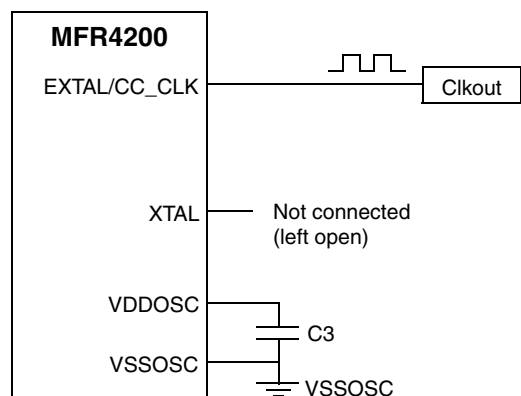

Where:

G = 40MHz CMOS-compatible External Oscillator (VDDOSC-level)

Figure 2-4. External Clock Connections

2.2.4 Power Supply Pins

MFR4200 power and ground pins are summarized in [Table 2-8](#) and described below.

NOTE

All VSS pins must be connected together in the application.

Because fast signal transitions place high, short-duration current demands on the power supply, use bypass capacitors with high-frequency characteristics and place them as close to the MFR4200 as possible. Bypass requirements depend on how heavily the MFR4200 pins are loaded.

Table 2-8. MFR4200 Power and Ground Connection Summary

Mnemonic	Pin Number	Nominal Voltage	Description
	64-pin LQFP		
V _{DD2_5}	59	2.5V	Internal power and ground generated by internal regulator
V _{SS2_5}	60	0V	
V _{DDR}	20	3.3V	External power and ground, supply to supply to pin drivers and internal voltage regulator.
V _{SSR}	19	0V	
V _{DDX[1:4]}	8, 37, 54, 35	3.3V	External power and ground, supply to pin drivers.
V _{SSX[1:4]}	9, 38, 53, 31	0V	
V _{DDA}	50	3.3V	Operating voltage and ground for the internal voltage regulator.
V _{SSA}	49	0V	
V _{VDDOSC}	26	2.5V	Provides operating voltage and ground for the internal oscillator. This allows the supply voltage to the oscillator to be bypassed independently. Internal power and ground generated by internal regulator.
V _{VSSOSC}	23	0V	

2.2.4.1 VDDX, VSSX — Power and Ground Pins for I/O Drivers

External power and ground for I/O drivers.

2.2.4.2 VDDR, VSSR — Power and Ground Pins for I/O Drivers and Internal Voltage Regulator

External power and ground for I/O drivers and input to the internal voltage regulator.

NOTE

The VDDR pin enables the internal 3.3 V to 2.5 V voltage regulator. If this pin is tied to ground, the internal voltage regulator is turned off.

2.2.4.3 VDD2_5, VSS2_5 — Core Power Pins

Power is supplied to the MFR4200 core through VDD2_5 and VSS2_5. This 2.5 V supply is derived from the internal voltage regulator. No static load is allowed on these pins. If VDDR is tied to ground, the internal voltage regulator is turned off.

NOTE

No load is allowed except for bypass capacitors.

2.2.4.4 VDDA, VSSA — Power Supply Pins for VREG

VDDA, VSSA are the power supply and ground input pins for the voltage regulator. They also provide the reference voltages for the internal voltage regulator.

2.2.4.5 VDDOSC, VSSOSC — Power Supply Pins for OSC

VDDOSC, VSSOSC provide operating voltage and ground for the oscillator. This allows the supply voltage to the oscillator to be bypassed independently. This 2.5V voltage is generated by the internal voltage regulator.

NOTE

No load is allowed except for bypass capacitors.

2.3 System Clock Description

The internal Clock and Reset Generator block provides the internal clock signals for the FlexRay block and all other modules. [Figure 2-5](#) shows the clock connections from the CRG to all modules.

Refer to [Chapter 5, “Clocks and Reset Generator”](#) for detailed information on clock generation.

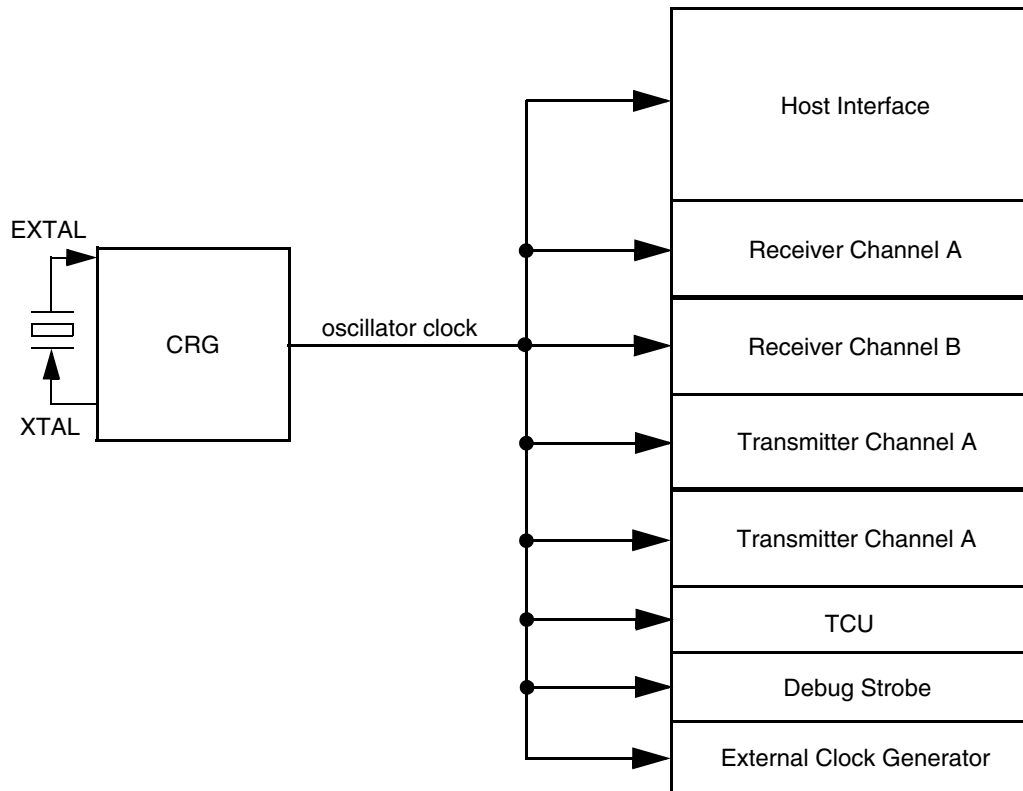

Figure 2-5. Clock Connections

2.4 Modes of Operation

2.4.1 Overview

The MFR4200 device operates only in one user mode — the normal mode. In normal mode, different host interfaces can be selected, each with its own associated external pin and interface configurations. The device has no low power modes.

2.4.2 Recommended Pullup/down Resistor Values

As IF_SEL[0:1] and CLK_S[0:1] signals share pins with physical layer interface signals, pullup/down devices must be used for selection. Recommended pullup/down resistor values for the IF_SEL[0:1] and CLK_S[0:1] inputs are given in [Table 2-9](#).

Table 2-9. Recommended Pullup/down Resistor Values for IF_SEL[0:1] and CLK_S[0:1] Inputs

IO, Regulator, and Analog Supply Level (V_{DD5})	Pullup Resistor ¹	Pulldown Resistor ¹	Units
3.3V	16	47	kOhm
5V	10	47	kOhm

¹ The listed values are calculated for the MFR4200 physical layer connection where no internal pullup/down resistors are assumed in the Electrical PHY at the TXD_BG1, BGT, ARM and MT interface lines. If an Electrical PHY device has internal pullup/down resistors connected to those signals, then the external pullup/down resistor values must be recalculated to ensure that V_{IL} requirements for pulldown resistors or V_{IH} requirements for pullup resistors for the chosen VDD5 are met. Refer to [Section A.1.9, “I/O Characteristics”](#) for more information on VIL, VIH and VDD5.

2.4.3 Host Controller Interfaces

The FlexRay communication controller can be connected to and controlled by microcontrollers with two types of interface. The MCU type is selected by the IF_SEL0 and IF_SEL1 inputs as shown in [Section 2.1.3.1, “Interface Selection”](#).

The CC latches the values of the IF_SEL0 and IF_SEL1 signals when it leaves the hard reset state. The CC configures the interface for the type of MCU based on the latched values. The CC latches the values again after it has left the hard reset state (see [Section 3.9.1, “Hard Reset State”](#)).

NOTE

If the CC senses an unsupported mode on its IF_SEL pins, it stops all internal operations, does not perform or respond to any host transactions, stays in configuration mode, and does not integrate into the communication process. The following steps must be taken to select a correct MCU interface mode:

1. IF_SEL0, IF_SEL1 must be set to AMI or to HCS12 mode;
2. The hard reset signal of the CC must be asserted again.

2.4.4 External Output Clock

The CC provides a continuous external output clock signal on the CLKOUT pin; this signal can be either disabled or set to a frequency of 4, 10, or 40 MHz. The signal is always active after the power-up of the CC, in all CC states including the hard reset state. The CLKOUT signal is disabled during the internal power-on and low voltage reset procedures (refer to [Chapter 5, “Clocks and Reset Generator”](#), [Section A.2.2, “Chip Power-up and Voltage Drops”](#), and the figures below ([Figure 2-6](#), [Figure 2-7](#), and [Figure 2-8](#)) for more information). The CLK_S[1:0] input pins enable/disable the CLKOUT signal and select its output frequency in accordance with the [Table 2-2](#).

[Figure 2-6](#) and [Figure 2-7](#) depict the CLKOUT generation during external hard reset and internal resets. Refer to [Chapter 5, “Clocks and Reset Generator](#) for more information.

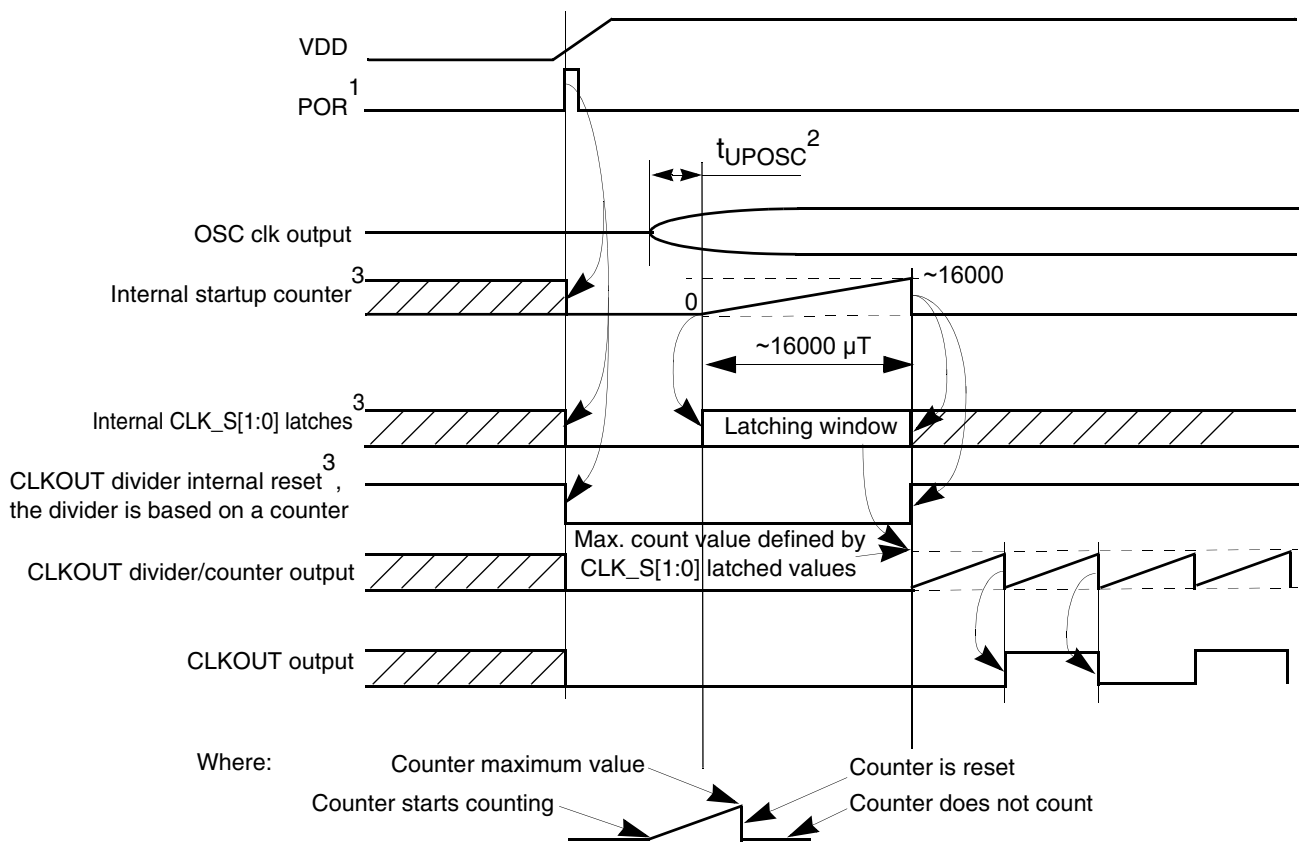

Notes:

- 1 For more information on the POR, refer to [A.2.2, “Chip Power-up and Voltage Drops”](#).
- 2 For more information on the t_{UPOSC} , refer to [A.3, “Reset and Oscillator”](#).
- 3 For more information on the Internal Startup Counter, the Internal CLK_S[1:0] latches, and the CLKOUT divider internal reset signals, refer to [Chapter 5, “Clocks and Reset Generator”](#).

Figure 2-6. CLKOUT Generation During Power-on Reset

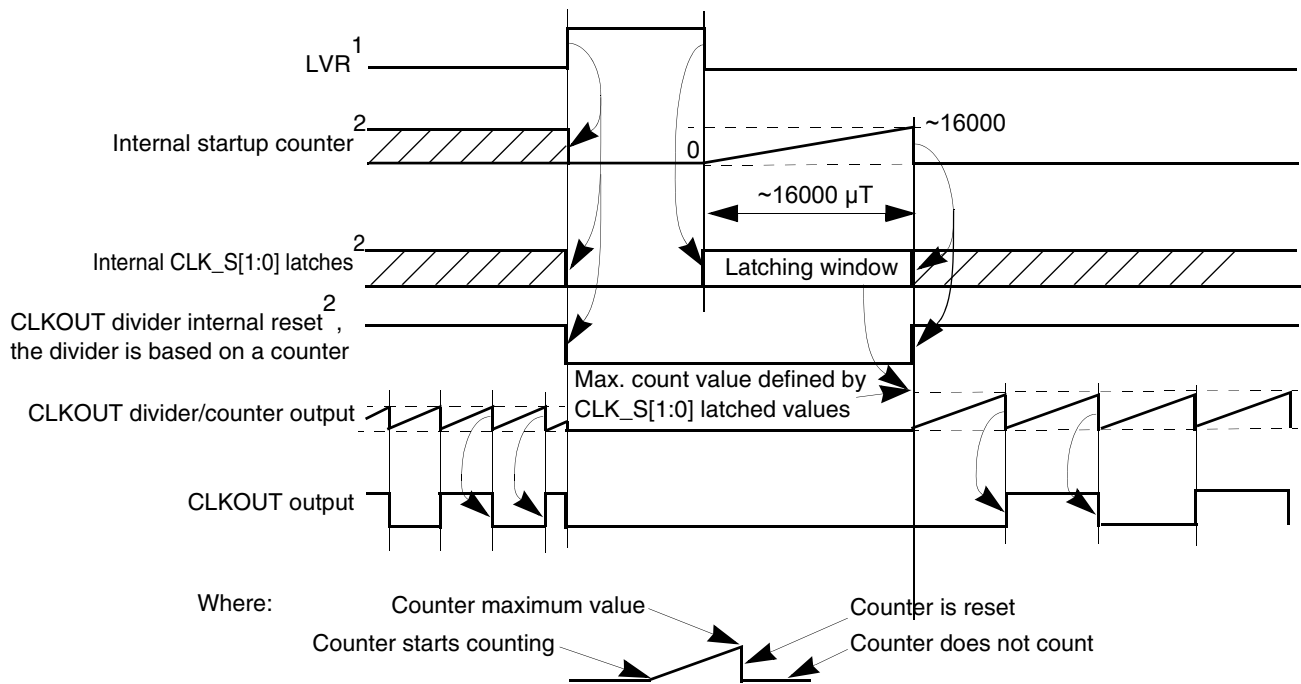

Notes:

- ¹ For more information about the POR, refer to [A.2.2, "Chip Power-up and Voltage Drops"](#).
- ² For more information about the Internal Startup Counter, the Internal CLK_S[1:0] latches, and the CLKOUT divider internal reset signals, refer to [Chapter 5, "Clocks and Reset Generator"](#).

Figure 2-7. CLKOUT Generation during Low Voltage Reset

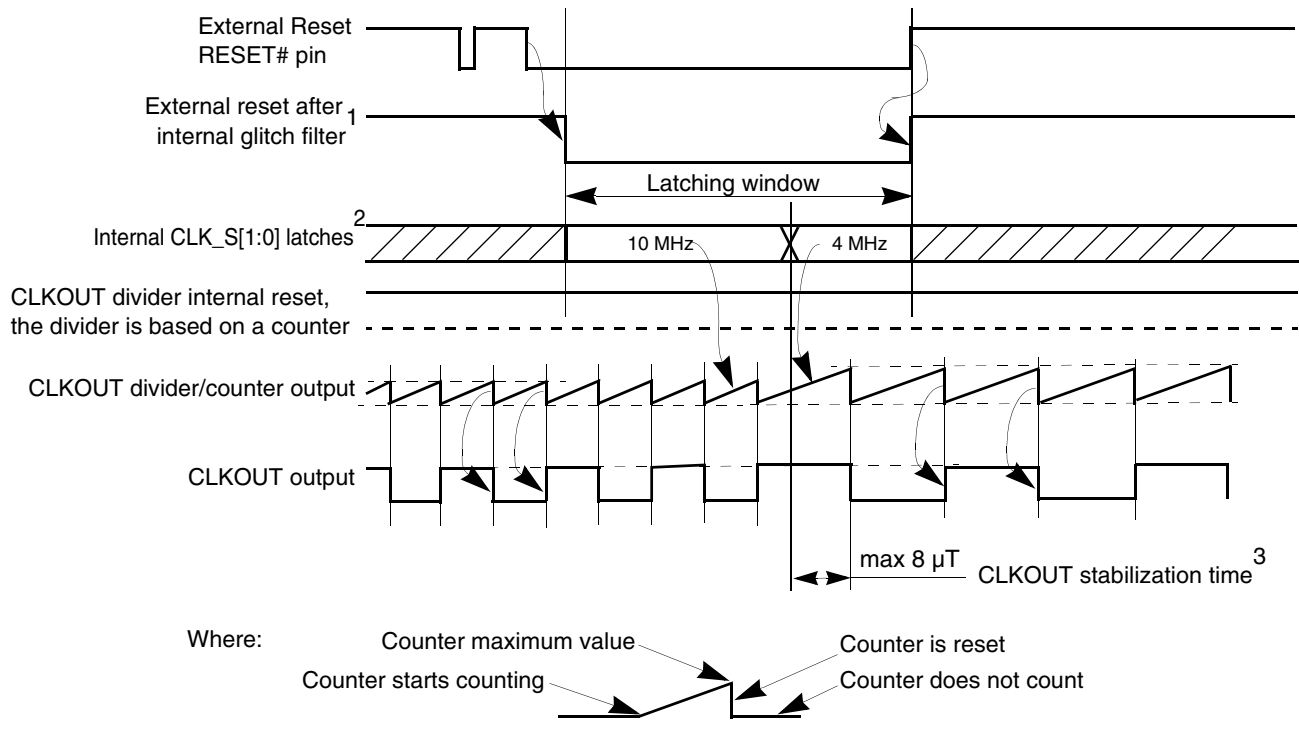

Notes:

- ¹ Refer to [Chapter 5, "Clocks and Reset Generator"](#) for more information on the reset glitch filter.
- ² For example, running at 10 MHz, then switching to 4 MHz.
- ³ When the external hard reset signal applied to the RESET# pin is negated, the CLKOUT signal frequency is stabilized after maximum 8 μT.

Figure 2-8. CLKOUT Generation During External Hard Reset

2.4.5 MFR4200 Connection to FlexRay Network

[Figure 2-9](#) shows an example of connecting a FlexRay Optical/Electrical PHY to the MFR4200. [Figure 2-10](#) shows how to connect the RS485 transceiver to the CC.

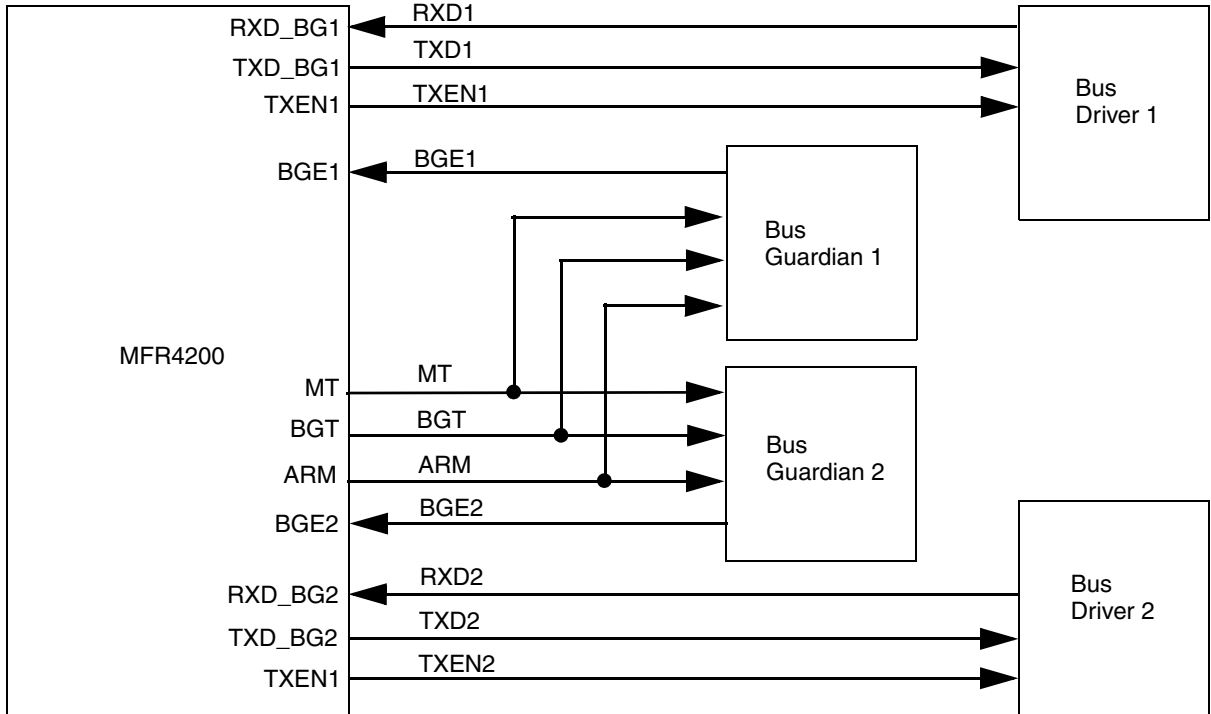

Figure 2-9. Example: Connecting a FlexRay Optical/Electrical PHY to the MFR4200

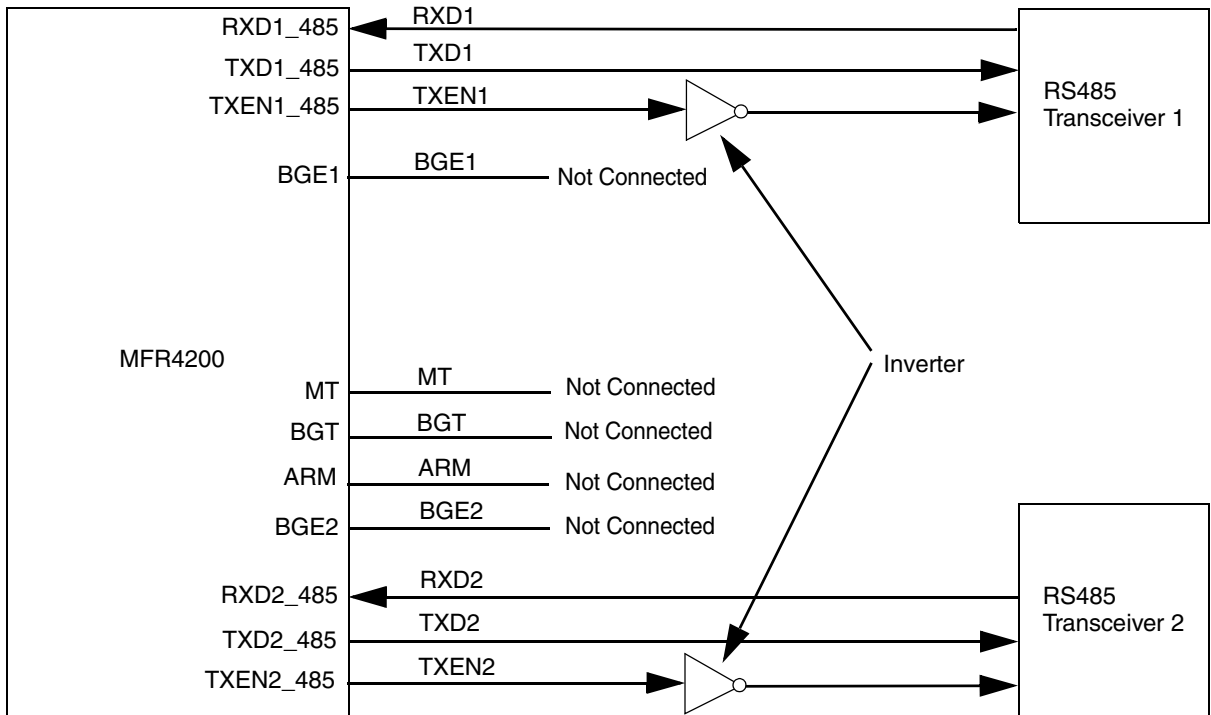

Figure 2-10. Example: Connecting an RS485 PHY to the MFR4200

NOTE

TXENn signals for the FlexRay Optical/Electrical PHY are multiplexed with TXENn_485 signals for the RS485 interfaces. Therefore, additional external inverters are required for these signals in the RS485 mode.

2.4.6 Power Mode

No power saving features are implemented in the MFR4200; the device operates only in power mode.

2.5 Resets and Interrupts

2.5.1 Overview

All possible MFR4200 internal interrupt sources are combined and provided to the host by means of one available interrupt line: INT_CC#. Refer to [Chapter 3, “MFR4200 FlexRay Communication Controller”](#) for more information on available interrupt sources. The type of interrupt is level sensitive.

MFR4200 has the following resets:

- external hard reset input signal RESET#.
- internal power-on and low-voltage resets provided by the internal voltage regulator (refer to [Chapter 5, “Clocks and Reset Generator”](#) and [Chapter 4, “Dual Output Voltage Regulator \(VREG3V3V2\)”](#) for more information).

2.5.2 Resets

When a reset occurs, MFR4200 registers and control bits are changed to known startup states. Refer to the respective module chapters for register reset states for information of the different kind of resets and for register reset states.

2.5.2.1 I/O Pins

Refer to [Chapter 3, “MFR4200 FlexRay Communication Controller”](#) for configuration of MFR4200 pins out of reset.

2.5.3 Interrupt Sources

All interrupt sources available in the MFR4200 are controlled and indicated by the following registers:

- Interrupt status register 0 (ISR0)
- Interrupt enable register 0 (IER0)
- Startup interrupt status register (SISR)
- Startup interrupt enable register (SIER)

For more information on interrupt sources, refer to [Chapter 3, “MFR4200 FlexRay Communication Controller”](#).

Chapter 3

MFR4200 FlexRay Communication Controller

3.1 Introduction

This version of the MFR4200 communication controller block guide supports MFR4200 devices with the mask numbers **0L60X** and **1L60X**.

3.1.1 MFR4200 Features

The MFR4200 provides the following features.

- The FlexRay protocol according to FlexRay Protocol Working document (PWD) V1.1, with differences described in the MFR4200 Protocol Implementation Document (PID)
- Data rate of up to 10 Mbit/s on each of two channels
- FlexRay frames with up to 254 payload bytes (padding is used for FlexRay payload data that exceeds 32-byte data size boundary)
- One configurable receive FIFO
- Configurable counters, status indicators, and interrupts dedicated to error signalling
- Measured value indicators for clock synchronization
- The status of up to four slots can be observed independently of CC receive message buffers
- Configurable error signaling
- Fractional macroticks (MT) supported for clock correction
- 59 message buffers, each with up to 32 payload bytes
- Message buffers configurable with state or event semantics
- Each message buffer can be configured as a receive message buffer, as a transmit message buffer (single or double), or as a part of the receive FIFO
- Receive background buffers for each channel
- The host accesses all buffers by means of three active message buffers (active transmit message buffer, active receive message buffer and active receive FIFO buffer)
- Filtering for frame ID, cycle counter, and channel for receive and transmit message buffers
- Filtering for frame ID, channel, and message ID for the receive FIFO
- Maskable interrupt sources provided over one interrupt line
- Two types of host interface: HCS12 interface and asynchronous memory interfaces
- Minislot action point offset is configurable
- Static slot action point offset is configurable
- Hardware selectable clock output to drive external host devices: disabled/4/10/40 MHz
- Electrical physical layer interface compatible with dedicated FlexRay physical layer. Industry standard RS485 physical layer interface also available.

3.1.2 MFR4200 Implementation Parameters and Constraints

3.1.2.1 Implementation Parameters

- The duration of a microtick (μT) is one CC_CLK period (25 ns at 40 MHz); a microtick starts with a rising edge of CC_CLK.
- The CC internal initialization procedure lasts for 1025 cycles of the CC_CLK clock; it starts after leaving the hard reset state (see [Section 3.9.1, “Hard Reset State”](#)).
- After the external hard reset signal on the RESET# pin is negated, the CLKOUT signal frequency is stabilized after 8 μT .

NOTE

Refer to [Section 3.8, “External 4/10 MHz Output Clock”](#) for more information on the CLKOUT output.

3.1.2.2 Implementation Constraints

- The maximum external clock frequency is 40 MHz (CC_CLK).
- Minislot length down to 2 μs (at CC_CLK frequency of 40 MHz) for the dynamic segment.
- Minislot length is configurable (minimum 2 MT).
- The maximum communication cycle length is 16 ms.
- Collision avoidance symbol length is set to 30 bits.
- The maximum configurable static slot length is 255 MT.

3.2 Memory Map and Registers

3.2.1 Introduction

This section describes the memory map, and the content and use of the registers in the host interface module. A memory map of the CC is shown in [Table 3-1](#).

The host accesses four types of CC registers:

- General control registers
- Buffer control, configuration, status and filtering register sets
- FIFO acceptance/rejection filter register sets
- Fifty-nine (59) configurable message buffers. The host can configure every buffer as a receive message buffer, as a transmit message buffer (single or double), or as a FIFO receive message buffer. All buffers are accessible through three active windows mirrored to the memory map:
 - One active transmit message buffer
 - One active receive message buffer
 - One active FIFO buffer

NOTE

The CC has two shadow receive message buffers per channel (four shadow buffers, in total); these allow reception while the host accesses the receive message buffers. One additional shadow message buffer is used for internal operations. Therefore, only 59 buffers out of 64 are available to the user as message buffers.

3.2.2 Register Map Summary**Table 3-1. Register Map Summary**

Register	Description	Address (Hex)	Address (Dec)	Hard Reset (Hex)
MNR	Magic Number Register	0	0	815
MVR0	Module Version Register 0	2	2	9042
MCR0	Module Configuration Register 0	4	4	8000
MCR1	Module Configuration Register 1	6	6	0
CMCVR	Current Macrotick Counter Value Register	8	8	0
CCCVR	Current Cycle Counter Value Register	0A	10	0
PSR	Protocol State Register	0C	12	0
ISR0	Interrupt Status Register 0	0E	14	0
SISR	Startup Interrupt Status Register	10	16	0
CHIER	CHI Error Register	12	18	0
IER0	Interrupt Enable Register 0	14	20	0
SIER	Startup Interrupt Enable Register	16	22	0
FSIZR	FIFO Size Register	18	24	0
FAFCHR	FIFO Acceptance/Rejection Filter Channel Register	1A	26	0
FAFMIDVR	FIFO Acceptance Filter Message ID Value Register	1C	28	0
FAFMIDMR	FIFO Acceptance Filter Message ID Mask Register	1E	30	0
FRFFIDVR	FIFO Rejection Filter Frame ID Value Register	20	32	0
FRFFIDMR	FIFO Rejection Filter Frame ID Mask Register	22	34	0
RBIVECR	Receive Buffer Interrupt Vector Register	24	36	0
TBIVECR	Transmit Buffer Interrupt Vector Register	26	38	0
SSCIR	Slot Status Counter Incrementation Register	28	40	0
SSCIMR	Slot Status Counter Interrupt Mask Register	2A	42	0

Table 3-1. Register Map Summary

Register	Description	Address (Hex)	Address (Dec)	Hard Reset (Hex)
CSECnR	Channel Status Error Counter n Register, n=[0:1]	2C, 2E	44, 46	0
TICR0CS	Timer Interrupt Configuration Register 0 Cycle Set	30	48	0
TICR0MO	Timer Interrupt Configuration Register 0 Macrotick Offset	32	50	0
TICR1CS	Timer Interrupt Configuration Register 1 Cycle Set	34	52	0
TICR1MO	Timer Interrupt Configuration Register 1 Macrotick Offset	36	54	0
DBPCR	Debug Port Control Register	38	56	0
BGSR	Bus Guardian Status Register	3A	58	0
DCR	Delay Counter Register	3C	60	0
NMVLN	Network Management Vector Length Register	3E	62	0
GNMVnR	Global Network Management Vector n Register, n=[0:5]	GNMV0R=40 GNMV1R=42 GNMV2R=44 GNMV3R=46 GNMV4R=48 GNMV5R=4A	GNMV0R=64 GNMV1R=66 GNMV2R=68 GNMV3R=70 GNMV4R=72 GNMV5R=74	0
SSCnR	Slot Status Counter n Register, n=[0:7]	SSC0R=4C SSC1R=4E SSC2R=50 SSC3R=52 SSC4R=54 SSC5R=56 SSC6R=58 SSC7R=5A	SSC0R=76 SSC1R=78 SSC2R=80 SSC3R=82 SSC4R=84 SSC5R=86 SSC6R=88 SSC7R=90	0
SSCCnR	Slot Status Counter Condition n Register, n=[0:7]	SSCC0R=5C SSCC1R=5E SSCC2R=60 SSCC3R=62 SSCC4R=64 SSCC5R=66 SSCC6R=68 SSCC7R=6A	SSCC0R=92 SSCC1R=94 SSCC2R=96 SSCC3R=98 SSCC4R=100 SSCC5R=102 SSCC6R=104 SSCC7R=106	0
SSSnR	Slot Status Selection n Register, n=[0:3]	SSS0R=6C SSS1R=6E SSS2R=70 SSS3R=72	SSS0R=108 SSS1R=110 SSS2R=112 SSS3R=114	0

Table 3-1. Register Map Summary

Register	Description	Address (Hex)	Address (Dec)	Hard Reset (Hex)
SSnR	Slot Status n Register, n=[0:7]	SS0R=74 SS1R=76 SS2R=78 SS3R=7A SS4R=7C SS5R=7E SS6R=80 SS7R=82	SS0R=116 SS1R=118 SS2R=120 SS3R=122 SS4R=124 SS5R=126 SS6R=128 SS7R=130	0
SWCTRLR	Symbol Window Control Register	84	132	0
SWSAR	Symbol Window Status channel A Register	86	134	0
SWSBR	Symbol Window Status channel B Register	88	136	0
WMCTRLR	Wakeup Mechanism Control Register	8A	138	0
NSSR	Number of Static Slots Register	8E	142	1
SPLR	Static Payload Length Register	90	144	0
MPLDR	Maximum Payload Length Dynamic Register	92	146	0
SYNCFR	Sync Frame Register	94	148	0
SYNCHR	Sync Frame Header Register	96	150	undefined
MVR1	Module Version Register 1	98	152	For mask set number: 0L60X – 0; 1L60X – 0001
HIPDSR	Host Interface Pins Drive Strength Register	9A	154	0
PLPDSR	Physical Layer Pins Drive Strength Register	9C	156	0
HIPPER	Host Interface Pins Pullup/down Enable Register	9E	158	0
HIPPCR	Host Interface Pins Pullup/down Control Register	A0	160	0
PLPPER	Physical Layer Pins Pullup/down Enable Register	A2	162	0
PLPPCR	Physical Layer Pins Pullup/down Control Register	A4	164	0
VREGSR	Voltage Regulator Status Register	A6	166	0
BDR	Bit Duration Register	A8	168	undefined
IDLDR	Idle Detection Length Register	AA	170	undefined
NMLR	Nominal Macrotick Length Register	AC	172	undefined
BGTR	Bus Guardian Tick Register	AE	174	undefined
SSLR	Static Slot Length Register	B0	176	undefined

Table 3-1. Register Map Summary

Register	Description	Address (Hex)	Address (Dec)	Hard Reset (Hex)
CLR	Cycle Length Register	B2	178	undefined
MPCLR	Microticks per Cycle Low Register	B4	180	undefined
MPCHR	Microticks per Cycle High Register	B6	182	undefined
MCLDAR	Maximum Cycle Length Deviation Register	B8	184	undefined
TSSLR	Transmit Start Sequence Length Register	BA	186	undefined
SWCR	Symbol Window Configuration Register	BC	188	undefined
NITCR	Network Idle Time Configuration Register	BE	190	undefined
CSMR	Coldstart Maximum Register	C0	192	undefined
MSFR	Maximum Sync Frames Register	C2	194	undefined
LDTSR	Latest Dynamic Transmission Start Register	C4	196	undefined
MSLR	Minislot Length Register	C6	198	undefined
MSAPOR	Minislot Action Point Offset Register	C8	200	undefined
SSAPOR	Static Slot Action Point Offset Register	CA	202	undefined
MOCWCFR	Maximum Odd Cycles Without Clock Correction Fatal Register	CC	204	undefined
DCAR	Delay Compensation Channel A Register	D0	208	undefined
DCBR	Delay Compensation Channel B Register	D2	210	undefined
LNLR	Listen timeout with Noise Length Register	D6	214	undefined
MOCWCPR	Maximum Odd Cycles Without clock Correction Passive Register	D8	216	undefined
MOCR	Maximum Offset Correction Register	DA	218	undefined
MRCR	Maximum Rate Correction Register	DC	220	undefined
CDDR	Cluster Drift Damping Register	DE	222	undefined
SOCCTR	Start of Offset Correction Cycle Time Register	E0	224	undefined
WUSTXIR	Wakeup Symbol TX Idle Register	EA	234	0
WUSTXLR	Wakeup Symbol TX Low Register	EC	236	0
SYNFAFMR	Sync Frame Acceptance Filter Mask Register	EE	238	undefined
SYNFAFVR	Sync Frame Acceptance Filter Value Register	F0	240	undefined
SYNFRFR	Sync Frame Rejection Filter Register	F2	242	undefined
EOCR	External Offset Correction Register	F4	244	undefined
ERCR	External Rate Correction Register	F6	246	undefined

Table 3-1. Register Map Summary

Register	Description	Address (Hex)	Address (Dec)	Hard Reset (Hex)
ECCR	External Correction Control Register	F8	248	undefined
AFBFRID	Active FIFO Buffer Frame ID Register	100	256	undefined
AFBCCPLR	Active FIFO Buffer Cycle Counter and Payload Length Register	102	258	undefined
AFBCRCR	Active FIFO Buffer Header CRC Register	104	260	undefined
AFBDATA _n R	Active FIFO Buffer Data n Register, n=[0:15]	ARFBDA0R=106 ... ARFBDA15R=124	ARFBDA0R=262 ... ARFBDA15R=292	undefined
AFBMBSSVR	Active FIFO Buffer Message Buffer Slot Status Vector Register	126	294	undefined
ARBFRID	Active Receive Buffer Frame ID Register	140	320	undefined
ARBCCPLR	Active Receive Buffer Cycle Counter and Payload Length Register	142	322	undefined
ARBCRCR	Active Receive Buffer Header CRC Register	144	324	undefined
ARBDATA _n R	Active Receive Buffer Data n Register, n=[0:15]	ARBDATA0R=146 ... ARBDATA15R=164	ARBDATA0R=326 ... ARBDATA15R=356	undefined
ARBMBSSVR	Active Receive Buffer Message Buffer Slot Status Vector Register	166	358	undefined
ATBFRID	Active Transmit Buffer Frame ID Register	180	384	undefined
ATBCCPLR	Active Transmit Buffer Cycle Counter and Payload Length Register	182	386	undefined
ATBCRCR	Active Transmit Buffer Header CRC Register	184	388	undefined
ATBDATA _n R	Active Transmit Buffer Data n Register, n=[0:15]	ATBDATA0R=186 ... ATBDATA15R=1A4	ATBDATA0R=390 ... ATBDATA15R=420	undefined
ATBMBSSVR	Active Transmit Buffer Message Buffer Slot Status Vector Register	1A6	422	undefined
BUFCS _n R	Message Buffer Control, Configuration and Status n Register, n=[0:58]	BUFCS0R=200 BUFCS1R=204 ... BUFCS57R=2E4 BUFCS58R=2E8	BUFCS0R=512 BUFCS1R=516 ... BUFCS57R=740 BUFCS58R=744	IFLG, IENA, CFG and VALID bits are reset to 0; others are undefined
CCF _n R	Cycle Counter Filter n Register, n=[0:58]	CCF0R=202 CCF1R=206 ... CCF57R=2E6 CCF58R=2EA.	CCF0R=514 CCF1R=518 ... CCF57R=742 CCF58R=746	undefined
CCFCR	Clock Correction Failed Counter Register	326	806	undefined
EHLR	Error Handling Level Register	328	808	undefined

Table 3-1. Register Map Summary

Register	Description	Address (Hex)	Address (Dec)	Hard Reset (Hex)
RCVR	Rate Correction Value Register	32A	810	undefined
OCVR	Offset Correction Value Register	32C	812	undefined
EMCR	Even Measurement Counter Register	33C	828	undefined
OMCR	Odd Measurement Counter Register	33E	830	undefined
EMAnR	Even Measurement channel A n Register, n=[0:15]	EMA0R=340 ... EMA15R=35E	EMA0R=832 ... EMA15R=862	undefined
EMBnR	Even Measurement channel B n Register, n=[0:15]	EMB0R=360 ... EMB15R=37E	EMB0R=864 ... EMB15R=894	undefined
ESFIDnR	Even Sync ID n Register, n=[0:15]	EID0R=380 ... EID15R=39E	EID0R=896 ... EID15R=926	undefined
OMAnR	Odd Measurement channel A n Register, n=[0:15]	OMA0R=3A0 ... OMA15R=3BE	OMA0R=928 ... OMA15R=958	undefined
OMBnR	Odd Measurement channel B n Register, n=[0:15]	OMB0R=3C0 ... OMB15R=3DE	OMB0R=960 ... OMB15R=990	undefined
OSFIDnR	Odd Sync Frame ID n Register, n=[0:15]	OSFID0R=3E0 ... OSFID15R=3FE	OSFID0R=1008 ... OSFID15R=1022	undefined

3.2.3 Register Descriptions

A condensed overview of all registers is provided in [Section 3.2.2, “Register Map Summary”](#)

NOTE

- All registers not shown in the CC memory map registers are not implemented in hardware.
- Any read operation on bits marked as ‘**Reserved**’ will return an undefined value (either ‘1’ or ‘0’).
- The host must take care that bits marked as ‘Reserved’ are set to 0 when writing.
- The reset value indicated for each register is the value that the register has after a hard reset operation.
- Meaning of the bit field character in the registers layout:
 - ‘**r**’ indicates that the bit-field may be read by host
 - ‘**w**’ denotes that the bit-field may be updated by host
 - ‘**h**’ means that the bit-field is updated by the communication controller

- Combinations such as ‘**rh**’, ‘**rw**’ or ‘**rwh**’ appear in the text indicating the different access possibilities.
- An additional asterisk ‘*’ indicates an exceptional behavior, i.e. under which conditions the host is allowed to write a ‘**rw**’ or ‘**rwh**’ bit-field, etc. In such cases, refer to the detailed bit-field description.
- Descriptions of configuration registers specify the possible range of values in square brackets – [,].

NOTE

The configuration registers’ possible ranges of values, specified in square brackets [:], denote only the MFR4200 implementation constraints. Not every configuration supported by the MFR4200 implementation is necessarily a valid configuration of an application network. For more information about configuration constraints, refer to the PWD: Configuration Constraints Notations chapter.

A key to the register diagrams is shown in [Figure 3-1](#).

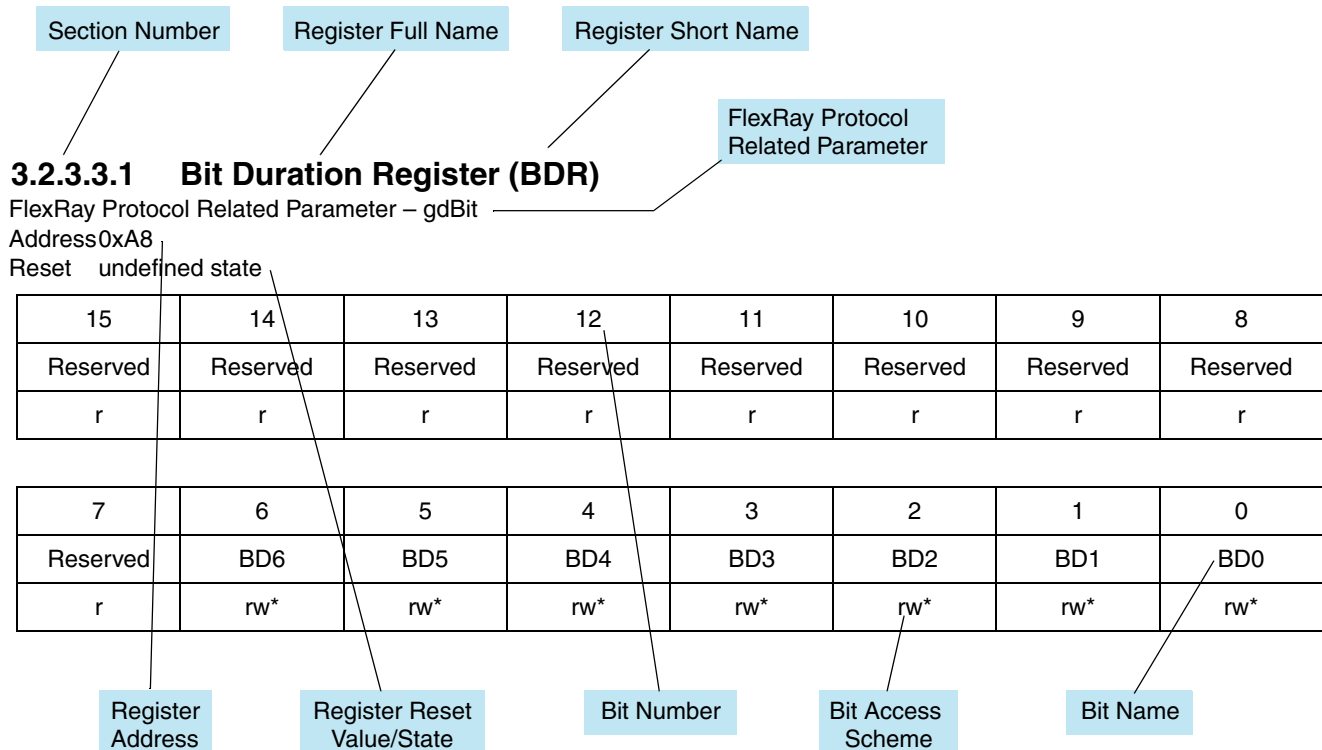

Figure 3-1. Key to Register Diagrams

3.2.3.1 Controller's Constants Registers

3.2.3.1.1 Module Version Register 0 (MVR0)

Address 0x2

Reset 0x9042

15	14	13	12	11	10	9	8
MJFR3	MJFR2	MJFR1	MJFR0	MINFR3	MINFR2	MINFR1	MINFR0
r	r	r	r	r	r	r	r

7	6	5	4	3	2	1	0
PDA7	PDA6	PDA5	PDA4	PDA3	PDA2	PDA1	PDA0
r	r	r	r	r	r	r	r

Figure 3-2. Module Version Register 0

The read-only MVR0, together with MVR1 (see following section), holds the version number of the implementation. The MVR0 contains the following fields:

PDA[0:7] denotes the device PartID1.

MINFR[0:3] denotes the minor release of the FlexRay core in the MFR4200 device.

MJFR[0:3] denotes the major release of the FlexRay core in the MFR4200 device.

3.2.3.1.2 Module Version Register 1 (MVR1)

Address 0x98

Reset

Device	Mask Set Number	Reset Value
MFR4200	0L60X	0x0000
MFR4200	1L60X	0x0001

15	14	13	12	11	10	9	8
PDB7	PDB6	PDB5	PDB4	PDB3	PDB2	PDB1	PDB0
r	r	r	r	r	r	r	r

7	6	5	4	3	2	1	0
MJMR3	MJMR2	MJMR1	MJMR0	MINMR3	MINMR2	MINMR1	MINMR0
r	r	r	r	r	r	r	r

Figure 3-3. Module Version Register 1

The read-only MVR1, together with MVR0 (see previous section), holds the version number of the implementation. The MVR1 contains:

PDB[0:7] denotes the device PartID2.

MINMR[0:3] denotes the minor release of the MFR4200 device.

MJMR[0:3] denotes the major release of the MFR4200 device.

3.2.3.1.3 Magic Number Register (MNR)

Address 0x0

Reset 0x0815

15	14	13	12	11	10	9	8
MN15	MN14	MN13	MN12	MN11	MN10	MN9	MN8
r	r	r	r	r	r	r	r
7	6	5	4	3	2	1	0
MN7	MN6	MN5	MN4	MN3	MN2	MN1	MN0
r	r	r	r	r	r	r	r

Figure 3-4. Magic Number Register

This read-only register contains the arbitrary value 0x0815; it is used for endianness and memory map address offset checks.

NOTE

The MNR contains 0x0000 while the controller is initializing after leaving the hard reset state. Only after this initialization is completed, does it contain the value 0x0815. After the controller leaves the hard reset state, the host must wait until the initialization is completed before reading or writing to the controller. The initialization takes 1025 cycles (CC_CLK) after de-assertion of the hard reset.

During the internal initialization procedure time, the host must not access any CC register except MNR (see [Section 3.2.3.1.3, “Magic Number Register \(MNR\)”](#)), which acknowledges the completion of the internal initialization procedure.

3.2.3.2 Configuration Registers

3.2.3.2.1 Module Configuration Register 0 (MCR0)

Address 0x4

Reset 0x8000

15	14	13	12	11	10	9	8
CONFIG	Reserved	Reserved	Reserved	Reserved	Reserved	CBE	CAE
rwh	r	r	r	r	r	rw*	rw*
7	6	5	4	3	2	1	0
Reserved	ENSYNFF	NSYNC	SCM1	SCM0	Reserved	DIAGSTOP	Reserved
r	rw*	rh	rw*	rw*	r	rw	r

Figure 3-5. Module Configuration Register 0

NOTE

Setting the CONFIG bit and writing to other bits in this register can be done in separate instructions only. Trying to set CONFIG and change other bits at the same time will change CONFIG only — the other bits will not be changed. Clearing CONFIG and writing to other bits in the MCR0 can be done simultaneously in one instruction.

DIAGSTOP — Diagnosis Stop State Bit

When this bit is set by the host, the CC immediately enters the Diagnosis Stop state. Any ongoing transmission or reception is aborted, and synchronization with the FlexRay communication bus is lost.

When this bit is cleared by the host, the controller enters the configuration state.

1 – The CC is in the Diagnosis Stop state.

0 – The CC is not in the Diagnosis Stop state.

SCM0, SCM1 — Serial Communication Mode Bits 0 and 1

These bits define the type of bus driver connected to the controller. It can be written during the configuration state only.

Table 3-2. Bus Driver Type Selection

Driver type	SCM1	SCM0
RS485 (IDLE state coded as “0”)	0	0
Optical/Electrical PHY	0	1
—	1	0
RS485 (IDLE state coded as “1”)	1	1

NOTE

It is not possible to mix different RS485's in a cluster or per channel, or to mix RS485 and Optical/Electrical PHY.

NSYNC — Node Synchronized

This read-only bit is set when the controller enters the normal state in the course of startup or reintegration. The NSYNC is set by the CC in the NIT preceding a transition to normal operation. The NSYNC is cleared by the CC in the NIT, prior to switching to the normal passive state (the 'yellow' error state; see [Section 3.2.3.6.5, "Error Handling Level Register \(EHLR\)"](#)) or the Diagnosis Stop state (the 'red' error state; see [Section 3.2.3.6.5, "Error Handling Level Register \(EHLR\)"](#)), due to...

- ...the correction value exceeding MRCR (see [Section 3.2.3.3.25, "Maximum Rate Correction Register \(MRCR\)"](#))
- ...the offset correction value exceeding MOCR (see [Section 3.2.3.3.24, "Maximum Offset Correction Register \(MOCR\)"](#))
- ...the CCFCR value (see [Section 3.2.3.6.4, "Clock Correction Failed Counter Register \(CCFCR\)"](#)) exceeding MOCWCPR (see [Section 3.2.3.5.3, "Maximum Odd Cycles Without clock Correction Passive Register \(MOCWCPR\)"](#)) or MOCWCFR (see [Section 3.2.3.5.2, "Maximum Odd Cycles Without Clock Correction Fatal Register \(MOCWCFR\)"](#)).

1 – Node is synchronized to cluster.

0 – Node is not synchronized to cluster.

ENSYNFF — Enable Sync Frame Filters

This bit enables/disables acceptance and rejection filtering for sync frames (see [Section 3.2.3.8.1, "Sync Frame Acceptance Filter Value Register \(SYNFAFVR\)"](#), [Section 3.2.3.8.2, "Sync Frame Acceptance Filter Mask Register \(SYNFAFMR\)"](#) and [Section 3.2.3.8.3, "Sync Frame Rejection Filter Register \(SYNFRFR\)"](#)).

1 – Sync frames are used for the clock synchronization only when they pass the acceptance filter and are not rejected by the rejection filter.

0 – Sync frames are used for the clock synchronization independently of the acceptance and rejection filter.

CAE — Channel A Enable

This bit enables channel A. It can be written during the configuration state only.

1 – Channel A is enabled.

0 – Channel A is disabled.

CBE — Channel B Enable

This bit enables channel B. It can be written during the configuration state only.

1 – Channel B is enabled.

0 – Channel B disabled.

CONFIG — Configuration State Bit

When the host sets this bit, the CC immediately enters the configuration state. The controller aborts any ongoing transmission or reception and abandons synchronization to the FlexRay cluster. When the host clears this bit, the controller resumes normal operation (see [Section 3.9.2, “Configuration State”](#)). After a hard reset, the controller automatically enters the configuration state (CONFIG bit set).

1 – Configuration state.

0 – Normal operation.

3.2.3.2.2 Module Configuration Register 1 (MCR1)

Address 0x6

Reset 0x0

15	14	13	12	11	10	9	8
Reserved	Reserved	Reserved	Reserved	Reserved	AYTG	ARL	CSI
r	r	r	r	r	rw*	rw*	rw*

7	6	5	4	3	2	1	0
Reserved	ECSE	BGSMDSE	BGSMSWE	Reserved	MATE	Reserved	Reserved
r	rw*	rw*	rw*	r	rw*	r	r

Figure 3-6. Module Configuration Register 1

MATE — Media Access Test Enable

This flag enables the media access test in the MFR4200 bus guardian (BG) monitor. This flag may be written in the configuration state only.

1 – Media access test is enabled.

0 – Media access test is disabled.

BGSMSWE — BG Schedule Monitoring Symbol Window Enable

This flag determines the behavior of the MFR4200 bus guardian schedule monitor during the symbol window. It may be written in the configuration state only.

1 – BG is expected to be open during symbol window of the communication cycle.

0 – BG is expected to be closed during symbol window of the communication cycle.

BGSMDSE — BG Schedule Monitoring Dynamic Segment Enable

This flag determines the behavior of the MFR4200 bus guardian monitor during the dynamic segment of the communication cycle. It may be written in the configuration state only.

1 – BG expected to be open during dynamic segment of the communication cycle.

0 – BG expected to be closed during dynamic segment of the communication cycle.

ECSE — External Clock Synchronization Enable

This configuration flag enables/disables the External Clock Synchronization. It can be written during the configuration state only.

- 1 – External Clock Synchronization is enabled.
- 0 – External Clock Synchronization is disabled.

CSI — Coldstart Inhibit Mode

The node can be prevented from initializing the TDMA communication schedule by setting the CSI bit to ‘1’ in the configuration state. It can be written during the configuration state only.

- 1 – Node is in Coldstart Inhibit mode.
- 0 – Node is not in Coldstart Inhibit mode.

ARL — Allow Red Level

If this bit is set, the transition to the red error handling level (Diagnosis Stop state) due to clock sync errors is allowed. It may be written in the configuration state only.

- 1 – Error handling level red is allowed (the CC enters the Diagnosis Stop state).
- 0 – Error handling level red is prohibited (the CC enters the configuration state).

AYTG — Allow Yellow to Green

If this bit is set, the transition from the yellow error handling level to the green error handling level is allowed. It may be written in the configuration state only.

- 1 – Transition from yellow to green is allowed.
- 0 – Transition from yellow to green is prohibited.

3.2.3.2.3 Host Interface and Physical Layer Pins Drive Strength Register (HIPDSR)

Address 0x9A
Reset 0x0

15	14	13	12	11	10	9	8
Reserved	Reserved	Reserved	Reserved	Reserved	Reserved	Reserved	Reserved
r	r	r	r	r	r	r	r
7	6	5	4	3	2	1	0
Reserved	Reserved	INT_CC#	CLKOUT	ARM/DBG1/ CLK_S0	MT/CLK_S1	BGT/DBG2/ IF_SEL0	PAD[0:15]/ D[15:0]
r	r	rw	rw	rw	rw	rw	rw

Figure 3-7. Host Interface Pins Drive Strength Register

This register controls the drive strength of the MFR4200 pins identified in [Figure 3-7](#).

1 – Pin drive strength is partial (see Appendix A.1.9, “I/O Characteristics”).

0 – Pin drive strength is full (see Appendix A.1.9, “I/O Characteristics”).

3.2.3.2.4 Physical Layer Pins Drive Strength Register (PLPDSR)

Address 0x9C

Reset 0x0

15	14	13	12	11	10	9	8
Reserved	Reserved	Reserved	Reserved	Reserved	Reserved	Reserved	Reserved
r	r	r	r	r	r	r	r
7	6	5	4	3	2	1	0
Reserved	Reserved	Reserved	Reserved	TXD_BG2/ TXD2_485	TXD_BG1/ TXD1_485/ IF_SEL1	TXEN2#/ TXE2_485#	TXEN1#/ TXE1_485#
r	r	r	r	rw	rw	rw	rw

Figure 3-8. Physical Layer Pins Drive Strength Register

This register controls the drive strength of the MFR4200 pins identified in Figure 3-8.

1 – Pin drive strength is partial (see Section A.1.9, “I/O Characteristics”).

0 – Pin drive strength is full (see Section A.1.9, “I/O Characteristics”).

3.2.3.2.5 Host Interface Pins Pullup/down Enable Register (HIPPER)

Address 0x9E

Reset 0x0

15	14	13	12	11	10	9	8
ECLK_CC	WE#/ RW_CC#	CE#/LSTRB	D[15:0]/ PAD[0:15]	ACS5	ACS4	OE#/ACS3	A9/ACS2
rw	rw	rw	rw	rw	rw	rw	rw
7	6	5	4	3	2	1	0
A8/ACS1	A7/ACS0	A6/ XADDR14	A5/ XADDR15	A4/ XADDR16	A3/ XADDR17	A2/ XADDR18	A1/ XADDR19
rw	rw	rw	rw	rw	rw	rw	rw

Figure 3-9. Host Interface Pins Pullup/down Enable Register

This register enables the pullups and pulldowns on MFR4200 pins identified in Figure 3-9. The pullup/down state is controlled by the HIPPCR (see Section 3.2.3.2.6, “Host Interface Pins Pullup/down Control Register (HIPPCR)”).

1 – Pullup/down resistor enabled.

0 – Pullup/down resistor disabled.

3.2.3.2.6 Host Interface Pins Pullup/down Control Register (HIPPCR)

Address 0xA0

Reset 0x0

15	14	13	12	11	10	9	8
ECLK_CC	WE#/RW_CC#	CE#/LSTRB	D[15:0]/PAD[0:15]	ACS5	ACS4	OE#/ACS3	A9/ACS2
rw	rw	rw	rw	rw	rw	rw	rw

7	6	5	4	3	2	1	0
A8/ACS1	A7/ACS0	A6/XADDR14	A5/XADDR15	A4/XADDR16	A3/XADDR17	A2/XADDR18	A1/XADDR19
rw	rw	rw	rw	rw	rw	rw	rw

Figure 3-10. Host Interface Pins Pullup/down Control Register

This register controls the pullups and pulldowns on MFR4200 pins identified in Figure 3-10. These functions can be enabled/disabled by the HIPPER (see Section 3.2.3.2.5, “Host Interface Pins Pullup/down Enable Register (HIPPER)”).

1 – Pullup selected.

0 – Pulldown selected.

3.2.3.2.7 Physical Layer Pins Pullup/down Enable Register (PLPPER)

Address 0xA2

Reset 0x0

15	14	13	12	11	10	9	8
Reserved	Reserved	Reserved	Reserved	Reserved	Reserved	Reserved	Reserved
r	r	r	r	r	r	r	r

7	6	5	4	3	2	1	0
Reserved	Reserved	Reserved	Reserved	BGEN2	BGEN1	RXD_BG2/RXD2_485	RXD_BG1/RXD1_485
r	r	r	r	rw	rw	rw	rw

Figure 3-11. Physical Layer Pins Pullup/down Enable Register

This register enables the pullups and pulldowns on MFR4200 pins identified in Figure 3-11. The pullup/down state is controlled by the PLPPCR (see Section 3.2.3.2.8, “Physical Layer Pins Pullup/down Control Register (PLPPCR)”).

1 – Pullup/down enabled.

0 – Pullup/down disabled.

3.2.3.2.8 Physical Layer Pins Pullup/down Control Register (PLPPCR)

Address 0xA4
Reset 0x0

15	14	13	12	11	10	9	8
Reserved	Reserved	Reserved	Reserved	Reserved	Reserved	Reserved	Reserved
r	r	r	r	r	r	r	r

7	6	5	4	3	2	1	0
Reserved	Reserved	Reserved	Reserved	BGEN2	BGEN1	RXD_BG2/ RXD2_485	RXD_BG1/RX D1_485
r	r	r	r	rw	rw	rw	rw

Figure 3-12. Physical Layer Pins Pullup/down Control Register

This register controls the pullups and pulldowns on MFR4200 pins identified in [Figure 3-12](#). These function can be enabled/disabled by the PLPPER (see [Section 3.2.3.2.7, “Physical Layer Pins Pullup/down Enable Register \(PLPPER\)”](#)).

1 – Pullup selected.

0 – Pulldown selected.

3.2.3.2.9 Voltage Regulator Status Register (VREGSR)

Address 0xA6
Reset

15	14	13	12	11	10	9	8
Reserved	Reserved	Reserved	Reserved	Reserved	Reserved	Reserved	Reserved
r	r	r	r	r	r	r	r

7	6	5	4	3	2	1	0
Reserved	Reserved	Reserved	Reserved	Reserved	Reserved	Low-voltage Status	Power-on Status
r	r	r	r	r	r	rwh	rwh

Figure 3-13. Voltage Regulator Status Register

This register indicates the occurrence of internal low-voltage and/or power-on reset events caused by power-on of MFR4200 device or supply voltage disturbances. The Low-voltage Status and Power-on Status bits do not cause an interrupt over the INT_CC# pin; therefore, the host may read this register to check the status.

The host clears any status bit in VREGSR by reading VREGSR. The CC sets a status bit in the VREGSR again when it detects the condition for that bit.

Low-voltage Status, Power-on Status

1 – MFR4200 has been reset internally due to reset conditions sensed by the voltage regulator.

0 – MFR4200 has not been reset internally.

NOTE

Low-voltage and power-on events generated by the MFR4200 voltage regulator cause the internal MFR4200 reset with the same consequences as in the case of an external hard reset. Therefore, changes to the VREGSR bits can be read by the host only after the MFR4200 leaves the internal reset state.

3.2.3.3 Control Registers

3.2.3.3.1 Bit Duration Register (BDR)

FlexRay Protocol Related Parameter – gdBit

Address 0xA8

Reset undefined state

15	14	13	12	11	10	9	8
Reserved	Reserved	Reserved	Reserved	Reserved	Reserved	Reserved	Reserved
r	r	r	r	r	r	r	r
7	6	5	4	3	2	1	0
Reserved	BD6	BD5	BD4	BD3	BD2	BD1	BD0
r	rw*	rw*	rw*	rw*	rw*	rw*	rw*

Figure 3-14. Bit Duration Register

This register controls the number of microticks per bit. Writing this register is possible only during the configuration state.

3.2.3.3.2 Delay Compensation Channel A Register (DCAR)

FlexRay Protocol Related Parameter – pDelayCompensation[A]

Address 0xD0

Reset undefined state

15	14	13	12	11	10	9	8
DCA15	DCA14	DCA13	DCA12	DCA11	DCA10	DCA9	DCA8
rw*	rw*	rw*	rw*	rw*	rw*	rw*	rw*

7	6	5	4	3	2	1	0
DCA7	DCA6	DCA5	DCA4	DCA3	DCA2	DCA1	DCA0
rw*	rw*	rw*	rw*	rw*	rw*	rw*	rw*

Figure 3-15. Delay Compensation Channel A Register

This register holds the value used to compensate for reception delays on channel A in microticks. The register can be written during the configuration state only. The value of this register must be within the range [0:127].

3.2.3.3.3 Delay Compensation Channel B Register (DCBR)

FlexRay Protocol Related Parameter – pDelayCompensation[B]

Address 0xD2

Reset undefined state

15	14	13	12	11	10	9	8
DCB15	DCB14	DCB13	DCB12	DCB11	DCB10	DCB9	DCB8
rw*	rw*	rw*	rw*	rw*	rw*	rw*	rw*

7	6	5	4	3	2	1	0
DCB7	DCB6	DCB5	DCB4	DCB3	DCB2	DCB1	DCB0
rw*	rw*	rw*	rw*	rw*	rw*	rw*	rw*

Figure 3-16. Delay Compensation Channel B Register

This register holds the value used to compensate for reception delays on channel B in microticks. The register can be written during the configuration state only. The value of this register must be within the range [0:127].

3.2.3.3.4 Cluster Drift Damping Register (CDDR)

FlexRay Protocol Related Parameter – pClusterDriftDamping

Address 0xDE

Reset undefined state

15	14	13	12	11	10	9	8
CDD15	CDD14	CDD13	CDD12	CDD11	CDD10	CDD9	CDD8
rw*	rw*	rw*	rw*	rw*	rw*	rw*	rw*
7	6	5	4	3	2	1	0
CDD7	CDD6	CDD5	CDD4	CDD3	CDD2	CDD1	CDD0
rw*	rw*	rw*	rw*	rw*	rw*	rw*	rw*

Figure 3-17. Cluster Drift Damping Register

This register defines the value used, in clock synchronization, to minimize the accumulation of rounding errors. This register can be written in the configuration state only. The register value is given in microticks and must be within the range [1:15].

3.2.3.3.5 Maximum Sync Frames Register (MSFR)

FlexRay Protocol Related Parameter – gSyncNodeMax

Address 0xC2

Reset undefined state

15	14	13	12	11	10	9	8
MSF15	MSF14	MSF13	MSF12	MSF11	MSF10	MSF9	MSF8
rw*	rw*	rw*	rw*	rw*	rw*	rw*	rw*
7	6	5	4	3	2	1	0
MSF7	MSF6	MSF5	MSF4	MSF3	MSF2	MSF1	MSF0
rw*	rw*	rw*	rw*	rw*	rw*	rw*	rw*

Figure 3-18. Maximum Sync Frames Register

This register holds the maximum number of sync frames that can be transmitted on either channel in a network, including a node's own sync frame. The host may modify this register in the configuration state only. The value of this register must be within the range [2:15].

3.2.3.3.6 Nominal Macrotick Length Register (NMLR)

FlexRay Protocol Related Parameter – pMicroPerMacroNom

Address 0xAC

Reset undefined state

15	14	13	12	11	10	9	8
Reserved	Reserved	Reserved	Reserved	Reserved	Reserved	Reserved	Reserved
r	r	r	r	r	r	r	r

7	6	5	4	3	2	1	0
NML7	NML6	NML5	NML4	NML3	NML2	NML1	NML0
rw*	rw*	rw*	rw*	rw*	rw*	rw*	rw*

Figure 3-19. Nominal Macrotick Length Register

This register defines the integer number of microticks per nominal macrotick, according to [Equation 3-1](#).

$$\text{NMLR} = \text{int}(\text{cycle length in } \mu\text{T} / \text{CLR}) \quad \text{Eqn. 3-1}$$

Writing this register is possible only in the configuration state.

3.2.3.3.7 Microticks Per Cycle Low Register (MPCLR)

Address 0xB4

Reset undefined state

15	14	13	12	11	10	9	8
MPCL15	MPCL14	MPCL13	MPCL12	MPCL11	MPCL10	MPCL9	MPCL8
rw*	rw*	rw*	rw*	rw*	rw*	rw*	rw*

7	6	5	4	3	2	1	0
MPCL7	MPCL6	MPCL5	MPCL4	MPCL3	MPCL2	MPCL1	MPCL0
rw*	rw*	rw*	rw*	rw*	rw*	rw*	rw*

Figure 3-20. Microticks Per Cycle Low Register

The MPCHR and MPCLR are described in the following section.

The MPCLR can be written during the configuration state only.

3.2.3.3.8 Microticks Per Cycle High Register (MPCHR)

Address 0xB6

Reset undefined state

15	14	13	12	11	10	9	8
Reserved	Reserved	Reserved	Reserved	Reserved	Reserved	Reserved	Reserved
r	r	r	r	r	r	r	r

7	6	5	4	3	2	1	0
MPCH7	MPCH6	MPCH5	MPCH4	MPCH3	MPCH2	MPCH1	MPCH0
rw*	rw*	rw*	rw*	rw*	rw*	rw*	rw*

Figure 3-21. Microticks Per Cycle High Register

The MPCHR and MPCLR define the number of microticks per cycle. Writing these registers is possible only in the configuration state. The relationship between registers MPCHR, MPCLR, and CLR is given by [Equation 3-2](#).

$$\text{MPCHR} * 2^{16} + \text{MPCLR} = (\text{Cycle Length}) - k * \text{CLR} \quad \text{Eqn. 3-2}$$

Where:

- Cycle Length = the length of a communication cycle in microticks
- $k = 1$ [microtick/macrotick]

3.2.3.3.9 Static Slot Length Register (SSLR)

FlexRay Protocol Related Parameter – gdStaticSlot

Address 0xB0

Reset undefined state

15	14	13	12	11	10	9	8
Reserved	Reserved	Reserved	Reserved	Reserved	Reserved	Reserved	Reserved
r	r	r	r	r	r	r	r

7	6	5	4	3	2	1	0
SSL7	SSL6	SSL5	SSL4	SSL3	SSL2	SSL1	SSL0
rw*	rw*	rw*	rw*	rw*	rw*	rw*	rw*

Figure 3-22. Static Slot Length Register

This register defines the number of macroticks per slot. Writing this register is possible only in the configuration state.

3.2.3.3.10 Number of Static Slots Register (NSSR)

FlexRay Protocol Related Parameter – gNumberOfStaticSlots

Address 0x8E

Reset 0x1

15	14	13	12	11	10	9	8
Reserved	Reserved	Reserved	Reserved	Reserved	NSS10	NSS9	NSS8
r	r	r	r	r	rw*	rw*	rw*

7	6	5	4	3	2	1	0
NSS7	NSS6	NSS5	NSS4	NSS3	NSS2	NSS1	NSS0
rw*	rw*	rw*	rw*	rw*	rw*	rw*	rw*

Figure 3-23. Number of Static Slots Register

This register defines the number of static slots in a cycle. Writing this register is possible only during the configuration state.

NOTE

The range of possible values for the NSSR is from 0x2 to 0x3FF. This means that **at least two static slots must be programmed.**

3.2.3.3.11 Static Payload Length Register (SPLR)

FlexRay Protocol Related Parameter – gPayloadLengthStatic

Address 0x90

Reset 0x0

15	14	13	12	11	10	9	8
Reserved	Reserved	Reserved	Reserved	Reserved	Reserved	Reserved	Reserved
r	r	r	r	r	r	r	r

7	6	5	4	3	2	1	0
Reserved	SPL6	SPL5	SPL4	SPL3	SPL2	SPL1	SPL0
r	rw*	rw*	rw*	rw*	rw*	rw*	rw*

Figure 3-24. Static Payload Length Register

This register defines the maximum data length for static frames in words (1 word = 2 bytes). Writing this register is possible only during the configuration state.

3.2.3.3.12 Minislot Length Register (MSLR)

FlexRay Protocol Related Parameter – gdMinislot

Address 0xC6

Reset undefined state

15	14	13	12	11	10	9	8
Reserved	Reserved	Reserved	Reserved	Reserved	Reserved	Reserved	Reserved
r	r	r	r	r	r	r	r

7	6	5	4	3	2	1	0
Reserved	MSL6	MSL5	MSL4	MSL3	MSL2	MSL1	MSL0
r	rw*	rw*	rw*	rw*	rw*	rw*	rw*

Figure 3-25. Minislot Length Register

This register defines the minislot length in macroticks. The register can be written during the configuration state only. The value of this register must be within the range [2:63].

3.2.3.3.13 Minislot Action Point Offset Register (MSAPOR)

FlexRay Protocol Related Parameter – gdMinislotActionPointOffset

Address 0xC8

Reset undefined state

15	14	13	12	11	10	9	8
Reserved	Reserved	Reserved	Reserved	Reserved	Reserved	Reserved	Reserved
r	r	r	r	r	r	r	r

7	6	5	4	3	2	1	0
Reserved	Reserved	Reserved	Reserved	MSAPO3	MSAPO2	MSAPO1	MSAPO0
r	r	r	r	rw*	rw*	rw*	rw*

Figure 3-26. Minislot Action Point Offset Register

This register defines the offset of the action point within the minislot in macroticks. The register can be written during the configuration state only. The value of this register must be within the range [1:15].

3.2.3.3.14 Static Slot Action Point Offset Register (SSAPOR)

FlexRay Protocol Related Parameter – gdActionPointOffset

Address 0xCA

Reset undefined state

15	14	13	12	11	10	9	8
Reserved	Reserved	Reserved	Reserved	Reserved	Reserved	Reserved	Reserved
r	r	r	r	r	r	r	r

7	6	5	4	3	2	1	0
Reserved	Reserved	Reserved	Reserved	SSAPO3	SSAPO2	SSAPO1	SSAPO0
r	r	r	r	rw*	rw*	rw*	rw*

Figure 3-27. Static Slot Action Point Offset Register

This register defines the offset of the action point in macroticks. The register can be written only during the configuration state. The value of this register must be within the range [1:15].

3.2.3.3.15 Latest Dynamic Transmission Start Register (LDTSR)

FlexRay Protocol Related Parameter – pLatestTx

Address 0xC4

Reset undefined state

15	14	13	12	11	10	9	8
Reserved	Reserved	LDT13	LDT12	LDT11	LDT10	LDT9	LDT8
r	r	rw*	rw*	rw*	rw*	rw*	rw*

7	6	5	4	3	2	1	0
LDT7	LDT6	LDT5	LDT4	LDT3	LDT2	LDT1	LDT0
rw*	rw*	rw*	rw*	rw*	rw*	rw*	rw*

Figure 3-28. Latest Dynamic Transmission Start Register

This register defines the cycle time after which dynamic frame transmission can start. If the cycle time is greater than this register's value, the controller continues an ongoing dynamic frame transmission (started before this point in time) and does not start any new dynamic frame transmissions. The latest dynamic transmission start is expressed in macroticks. The register can be written only in the configuration state.

3.2.3.3.16 Maximum Payload Length Dynamic Register (MPLDR)

FlexRay Protocol Related Parameter – gMaxPayloadLengthDynamic

Address 0x92

Reset 0x0

15	14	13	12	11	10	9	8
Reserved	Reserved	Reserved	Reserved	Reserved	Reserved	Reserved	Reserved
r	r	r	r	r	r	r	r

7	6	5	4	3	2	1	0
Reserved	MPLD6*	MPLD5*	MPLD4*	MPLD3*	MPLD2*	MPLD1*	MPLD0*
r	rw*	rw*	rw*	rw*	rw*	rw*	rw*

Figure 3-29. Maximum Payload Length Dynamic Register

This register defines the maximum payload length in the dynamic segment, in terms of words (1 word = 2 bytes). This register can be written only during the configuration state.

NOTE

The value of the maximum payload length dynamic register is used for checking transmit message buffers (see the MDPLE bit description in [Section 3.2.3.6.3, “CHI Error Register \(CHIER\)”](#) and [Section 3.3.2.7, “LEN\[6: 0\] — Payload Length”](#)).

3.2.3.3.17 Symbol Window Configuration Register (SWCR)

FlexRay Protocol Related Parameter – gdSymbolWindow

Address 0xBC

Reset undefined state

15	14	13	12	11	10	9	8
Reserved	Reserved	SWC13	SWC12	SWC11	SWC10	SWC9	SWC8
r	r	rw*	rw*	rw*	rw*	rw*	rw*

7	6	5	4	3	2	1	0
SWC7	SWC6	SWC5	SWC4	SWC3	SWC2	SWC1	SWC0
rw*	rw*	rw*	rw*	rw*	rw*	rw*	rw*

Figure 3-30. Symbol Window Configuration Register

This register defines the cycle time in which the symbol window starts. The cycle time is measured in macroticks. This register may be modified only in the configuration state.

3.2.3.3.18 Network Idle Time Configuration Register (NITCR)

FlexRay Protocol Related Parameter – gdNIT

Address 0xBE

Reset undefined state

15	14	13	12	11	10	9	8
Reserved	Reserved	NITC13	NITC12	NITC11	NITC10	NITC9	NITC8
r	r	rw*	rw*	rw*	rw*	rw*	rw*

7	6	5	4	3	2	1	0
NITC7	NITC6	NITC5	NITC4	NITC3	NITC2	NITC1	NITC0
rw*	rw*	rw*	rw*	rw*	rw*	rw*	rw*

Figure 3-31. Network Idle Time Configuration Register

This register defines the cycle time in which the network idle time starts. The cycle time is measured in macroticks. The register may be modified in the configuration state only. This register is related to the SOCCTR register (refer to the note in [Section 3.2.3.3.34, “Start of Offset Correction Cycle Time Register \(SOCCTR\)”](#)).

NOTE

Since the duration of the NIT must be longer than or equal to

$$\text{ceil}((1300\mu\text{T} + 170\mu\text{T} * \text{MSFR})/\text{NMLR}) + 1 \text{ [nominal MT]},$$

Eqn. 3-3

this register must be configured to, at most

$$\text{CLR} - \text{NIT duration [nominal MT]}$$

Eqn. 3-4

3.2.3.3.19 Cycle Length Register (CLR)

FlexRay Protocol Related Parameter – gMacroPerCycle

Address 0xB2

Reset undefined state

15	14	13	12	11	10	9	8
Reserved	Reserved	CL13	CL12	CL11	CL10	CL9	CL8
r	r	rw*	rw*	rw*	rw*	rw*	rw*

7	6	5	4	3	2	1	0
CL7	CL6	CL5	CL4	CL3	CL2	CL1	CL0
rw*	rw*	rw*	rw*	rw*	rw*	rw*	rw*

Figure 3-32. Cycle Length Register

This register defines the number of macroticks per cycle. Writing this register is possible during the configuration state only. The CC uses this register value during startup only.

3.2.3.3.20 Maximum Cycle Length Deviation Register (MCLDAR)

FlexRay protocol related parameter – gdMaxDrift

Address 0xB8

Reset undefined state

15	14	13	12	11	10	9	8
Reserved	Reserved	Reserved	Reserved	Reserved	Reserved	MCLDA9	MCLDA8
r	r	r	r	r	r	rw*	rw*

7	6	5	4	3	2	1	0
MCLDA7	MCLDA6	MCLDA5	MCLDA4	MCLDA3	MCLDA2	MCLDA1	MCLDA0
rw*	rw*	rw*	rw*	rw*	rw*	rw*	rw*

Figure 3-33. Maximum Cycle Length Deviation Register

This register defines the number of microticks for a communication cycle of another CC with the maximum deviation of 1500 ppm with respect to the local oscillator.

Writing this register is possible only during the configuration state. The value for the MCLDAR is calculated from [Equation 3-5](#):

$$\text{MCLDAR} = \text{ceil} (\text{cycle_length}[\mu\text{T}] * 1.5 * 10^{-3}) \quad \text{Eqn. 3-5}$$

3.2.3.3.21 External Offset Correction Register (EOCR)

FlexRay Protocol Related Parameter – pExternOffsetCorrection

Address 0xF4

Reset undefined state

15	14	13	12	11	10	9	8
EOC15	EOC14	EOC13	EOC12	EOC11	EOC10	EOC9	EOC8
rw*	rw*	rw*	rw*	rw*	rw*	rw*	rw*

7	6	5	4	3	2	1	0
EOC7	EOC6	EOC5	EOC4	EOC3	EOC2	EOC1	EOC0
rw*	rw*	rw*	rw*	rw*	rw*	rw*	rw*

Figure 3-34. External Offset Correction Register

This register holds the absolute value of the initial external offset correction to be applied, together with the internal clock synchronization value (see [Section 3.2.3.3.23, “External Correction Control Register \(ECCR\)”](#)). The host may write this register during the configuration state only. The register value is expressed in microticks.

3.2.3.3.22 External Rate Correction Register (ERCR)

FlexRay Protocol Related Parameter – pExternRateCorrection

Address 0xF6

Reset undefined state

15	14	13	12	11	10	9	8
ECR15	ECR14	ECR13	ECR12	ECR11	ECR10	ECR9	ECR8
rw*	rw*	rw*	rw*	rw*	rw*	rw*	rw*

7	6	5	4	3	2	1	0
ERC7	ERC6	ERC5	ERC4	ERC3	ERC2	ERC1	ERC0
rw*	rw*	rw*	rw*	rw*	rw*	rw*	rw*

Figure 3-35. External Rate Correction Register

This register holds the absolute value of the initial external rate correction to be applied, together with the internal clock synchronization value (see [Section 3.2.3.3.23, “External Correction Control Register \(ECCR\)”](#)). The host may write this register in the configuration state only. The register value is expressed in microticks.

3.2.3.3.23 External Correction Control Register (ECCR)

Address 0xF8

Reset undefined state

15	14	13	12	11	10	9	8
Reserved	Reserved	Reserved	Reserved	Reserved	Reserved	Reserved	Reserved
r	r	r	r	r	r	r	r

7	6	5	4	3	2	1	0
Reserved	Reserved	Reserved	Reserved	ERCA	ERCE	EOCA	EOCE
r	r	r	r	rw	rwh	rw	rwh

Figure 3-36. External Correction Control Register

NOTE

This register must be set before the NIT start of communication cycle x , in order to affect the clock correction in the communication cycle $x+1$.

EOCE — External Offset Correction Enable

0 – External offset correction disabled.

1 – External offset correction enabled.

NOTE

If this bit is set by the host, external offset correction will be performed once during the subsequent double cycle; afterwards, this bit will be cleared automatically by the communication controller.

EOCA — External Offset Correction Application

- 0 – Add external offset correction value.
- 1 – Subtract external offset correction value.

ERCE — External Rate Correction Enable

- 0 – External rate correction disabled.
- 1 – External rate correction enabled.

NOTE

If this bit is set by the host, the external rate correction will be performed once during the subsequent double cycle, and afterwards this bit will be automatically cleared by the communication controller.

ERCA — External Rate Correction Application

- 0 – Add external rate correction.
- 1 – Subtract external rate correction.

3.2.3.3.24 Maximum Offset Correction Register (MOCR)

FlexRay Protocol Related Parameter – pOffsetCorrectionOut

Address 0xDA

Reset undefined state

15	14	13	12	11	10	9	8
MOC15	MOC14	MOC13	MOC12	MOC11	MOC10	MOC9	MOC8
rw*	rw*	rw*	rw*	rw*	rw*	rw*	rw*

7	6	5	4	3	2	1	0
MOC7	MOC6	MOC5	MOC4	MOC3	MOC2	MOC1	MOC0
rw*	rw*	rw*	rw*	rw*	rw*	rw*	rw*

Figure 3-37. Maximum Offset Correction Register

This register defines the maximum permitted absolute offset correction value, in microticks, to be applied by the internal clock synchronization algorithms. This register can be written during the configuration state only. The value of this register does not effect the external clock correction value.

3.2.3.3.25 Maximum Rate Correction Register (MRCR)

FlexRay Protocol Related Parameter – pRateCorrectionOut

Address 0xDC

Reset undefined state

15	14	13	12	11	10	9	8
MRC15	MRC14	MRC13	MRC12	MRC11	MRC10	MRC9	MRC8
rw*	rw*	rw*	rw*	rw*	rw*	rw*	rw*

7	6	5	4	3	2	1	0
MRC7	MRC6	MRC5	MRC4	MRC3	MRC2	MRC1	MRC0
rw*	rw*	rw*	rw*	rw*	rw*	rw*	rw*

Figure 3-38. Maximum Rate Correction Register

This register defines the maximum permitted absolute rate correction value, in microticks, to be applied by the internal clock synchronization algorithms. This register can be written during the configuration state only. The value of this register does not effect the external clock correction value.

3.2.3.3.26 Coldstart Maximum Register (CSMR)

FlexRay Protocol Related Parameter – gColdStartAttempts

Address 0xC0

Reset undefined state

15	14	13	12	11	10	9	8
CMS15	CMS14	CMS13	CMS12	CMS11	CMS10	CMS9	CMS8
rw*	rw*	rw*	rw*	rw*	rw*	rw*	rw*

7	6	5	4	3	2	1	0
CSM7	CSM6	CSM5	CSM4	CSM3	CSM2	CSM1	CSM0
rw*	rw*	rw*	rw*	rw*	rw*	rw*	rw*

Figure 3-39. Coldstart Maximum Register

The value in this register determines the maximum number of coldstart attempts that a coldstarting startup node is allowed to make, when trying to start up the network without receiving a valid response from another node. After this number of coldstart attempts, the CC falls back to the integration listen state and does not perform another coldstart attempt, until the controller enters and leaves the configuration state again. If the register is programmed with the value '0', then the CC is not allowed to start communication. Writing the coldstart maximum register is possible during the configuration state only. The value of this register must be within the range [0:32767].

3.2.3.3.27 Transmit Start Sequence Length Register (TSSLR)

FlexRay Protocol Related Parameter – gdTSSTransmitter/pdTSSReceiver

Address 0xBA

Reset undefined state

15	14	13	12	11	10	9	8
TSSLR7	TSSLR6	TSSLR5	TSSLR4	TSSLR3	TSSLR2	TSSLR1	TSSLR0
rw*	rw*	rw*	rw*	rw*	rw*	rw*	rw*

7	6	5	4	3	2	1	0
TSSLT7	TSSLT6	TSSLT5	TSSLT4	TSSLT3	TSSLT2	TSSLT1	TSSLT0
rw*	rw*	rw*	rw*	rw*	rw*	rw*	rw*

Figure 3-40. Transmit Start Sequence Length Register

The TSSLR defines the length, in bits, of the transmit start sequence on the physical layer.

Bits TSSLT[0:7] (LSB) define the nominal length of the transmit start sequence for transmission.

Bits TSSLR[8:15] (MSB) define maximum length of the transmit start sequence for reception.

Writing is possible only during the configuration state.

3.2.3.3.28 Network Management Vector Length Register (NMVLR)

FlexRay Protocol Related Parameter – gNetworkManagementVectorLength

Address 0x3E

Reset 0x0

15	14	13	12	11	10	9	8
Reserved	Reserved	Reserved	Reserved	Reserved	Reserved	Reserved	Reserved
r	r	r	r	r	r	r	r

7	6	5	4	3	2	1	0
Reserved	Reserved	Reserved	Reserved	NMVL3	NMVL2	NMVL1	NMVL0
r	r	r	r	rw*	rw*	rw*	rw*

Figure 3-41. Network Management Vector Length Register

This register defines the length, in bytes, of the network management vector (see [Section 3.2.3.4.6, “Global Network Management Vector n Register, n = \[0:5\] \(GNMVnR\)”](#)). Writing is possible during the configuration state only. The value of this register must be within the range [0:12].

3.2.3.3.29 Sync Frame Register (SYNCFR)

Address 0x94
Reset 0x0

15	14	13	12	11	10	9	8
SUP	Reserved	Reserved	Reserved	Reserved	SYNCF10	SYNCF9	SYNCF8
rw*	r	r	r	r	rw*	rw*	rw*

7	6	5	4	3	2	1	0
SYNCF7	SYNCF6	SYNCF5	SYNCF4	SYNCF3	SYNCF2	SYNCF1	SYNCF0
rw*	rw*	rw*	rw*	rw*	rw*	rw*	rw*

Figure 3-42. Sync Frame Register

This register contains the identifier of the sync frame to be transmitted. This register can be written during the configuration state only. There is no sync frame to transmit, if this register holds the value 0x0. A hard reset clears the register.

SUP — Startup

This bit sets the startup frame indicator. It can be written in the configuration state only.

1 – CC is a startup node and has its startup frame indicator set.

0 – CC is not a startup node.

3.2.3.3.30 Sync Frame Header Register (SYNCHR)

Address 0x96
Reset undefined state

15	14	13	12	11	10	9	8
Reserved	Reserved	Reserved	Reserved	Reserved	SYNCR10	SYNCR9	SYNCR8
r	r	r	r	r	rw*	rw*	rw*

7	6	5	4	3	2	1	0
SYNCR7	SYNCR6	SYNCR5	SYNCR4	SYNCR3	SYNCR2	SYNCR1	SYNCR0
rw*	rw*	rw*	rw*	rw*	rw*	rw*	rw*

Figure 3-43. Sync Frame Header Register

This register contains the header CRC of the sync frame to be transmitted. This register can be written during the configuration state only.

NOTE

The SYNCHR value overwrites the header CRC field of a transmit message buffer that: a) has the same frame ID as the SYNCF[0:10] field of the SYNCFR (see [Section 3.2.3.3.29, “Sync Frame Register \(SYNCFR\)”](#)), and b) was selected by the CC for transmission as a sync message.

3.2.3.3.31 Bus Guardian Tick Register (BGTR)

Address 0xAE

Reset undefined state

15	14	13	12	11	10	9	8
Reserved	Reserved	Reserved	Reserved	Reserved	Reserved	Reserved	Reserved
r	r	r	r	r	r	r	r

7	6	5	4	3	2	1	0
Reserved	Reserved	Reserved	BGT4	BGT3	BGT2	BGT1	BGT0
r	r	r	rw*	rw*	rw*	rw*	rw*

Figure 3-44. Bus Guardian Tick Register

This register defines the period length of the bus guardian tick to be provided by the CC to the bus guardian.

The value BGT[0:4], is expressed in multiples of the CC microtick. Writing this register is possible only during the configuration state. The value of this register must be within the range [2:16].

3.2.3.3.32 Delay Counter Register (DCR)

Address 0x3C

Reset 0x0

15	14	13	12	11	10	9	8
DC15	DC14	DC13	DC12	DC11	DC10	DC9	DC8
rw*	rw*	rw*	rw*	rw*	rw*	rw*	rw*

7	6	5	4	3	2	1	0
DC7	DC6	DC5	DC4	DC3	DC2	DC1	DC0
rw*	rw*	rw*	rw*	rw*	rw*	rw*	rw*

Figure 3-45. Delay Counter Register

This register specifies the configurable part of the delay between the reset of the CONFIG bit (host writing MCR0.CONFIG) and the point in time when the controller actually leaves the configuration state (see [Section 3.9.2, “Configuration State”](#)). The delay is configurable in steps of eight microticks, i.e.

$$\text{the configured value} * 8 = \text{delay in microticks}$$

Eqn. 3-6

The host may write this register only during the configuration state.

3.2.3.3.33 Debug Port Control Register (DBPCR)

Address 0x38

Reset 0x0

15	14	13	12	11	10	9	8
Reserved	Reserved	Reserved	Reserved	Reserved	Reserved	Reserved	Reserved
r	r	r	r	r	r	r	r

7	6	5	4	3	2	1	0
CNTRL7	CNTRL6	CNTRL5	CNTRL4	CNTRL3	CNTRL2	CNTRL1	CNTRL0
rw	rw	rw	rw	rw	rw	rw	rw

Figure 3-46. Debug Port Control Register

This register controls the output functions of the BGT and ARM_BG pins of the controller as described in [Table 3-3](#).

Bits CNTRL[7:4] determine the functionality of the port BGT pin.

Bits CNTRL[3:0] determine the functionality of the port ARM_BG pin.

Refer to [3.10, “Debug Port”](#) for a detailed description of the debug functions.

NOTE

The output function controls of BGT and ARM_BG pins are independent of each other. Therefore, they may be set with equal or different values.

Table 3-3. Encoding of Debug Port Control Fields CNTRL[7:4] and CNTRL[3:0]

CNTRL[7:4], CNTRL[3:0]	Mode of the BGT, Mode of the ARM_BG	Signal
0	Normal operation of BGT and ARM_BG	–
1	Protocol state change	PCS
2	Slot start in static segment	SSS
3	Minislot start	MSS
4	RxD after glitch filter on channel A	RAGFA
5	Dynamic slot start on channel A	DSSA
6	Start of frame on channel A	SFA
7	Received syntactically correct and semantically valid frame indication on channel A	RCFA
8	Start of a communication cycle	SCC
9	Macro tick	MTS
10	Start of offset correction	SOC
11	–	–
12	RxD after glitch filter on channel B	RAGFB

Table 3-3. Encoding of Debug Port Control Fields CNTRL[7:4] and CNTRL[3:0] (continued)

CNTRL[7:4], CNTRL[3:0]	Mode of the BGT, Mode of the ARM_BG	Signal
13	Dynamic slot start on channel B	DSSB
14	Start of frame on channel B	SFB
15	Received syntactically correct an semantically valid frame indication on channel B	RCFB

3.2.3.3.34 Start of Offset Correction Cycle Time Register (SOCCTR)

FlexRay Protocol Related Parameter – gOffsetCorrectionStart

Address 0xE0

Reset undefined state

15	14	13	12	11	10	9	8
Reserved	Reserved	SOCCT13	SOCCT12	SOCCT11	SOCCT10	SOCCT9	SOCCT8
r	r	rw*	rw*	rw*	rw*	rw*	rw*
7	6	5	4	3	2	1	0
SOCCT7	SOCCT6	SOCCT5	SOCCT4	SOCCT3	SOCCT2	SOCCT1	SOCCT0
rw*	rw*	rw*	rw*	rw*	rw*	rw*	rw*

Figure 3-47. Start of Offset Correction Cycle Time Register

This register defines the delay time (in multiples of macroticks) after which the offset correction will start. Writing this register is possible only during the configuration state.

NOTE

The time interval between the start time of the NIT (see NITCR) and the Start of Offset Correction time is used by the CC for clock correction calculations. The minimum interval that must be ensured during NITCR and SOCCTR programming can be calculated from [Equation 3-7](#):

$$\text{Delaymin} = \text{ceil}(500\mu\text{T} + 110\mu\text{T} \cdot \text{MSFR}/\text{NMLR}) + 1 \text{ [nominal MT]} \quad \text{Eqn. 3-7}$$

Therefore, the SOCCTR value must be:

$$\text{SOCCTR} \geq \text{NITCR} + \text{Delaymin} \text{ [nominal MT]} \quad \text{Eqn. 3-8}$$

3.2.3.3.35 Idle Detection Length Register (IDLR)

FlexRay protocol related parameter – gdDynamicSlotIdlePhase

Address 0xAA

Reset undefined state

15	14	13	12	11	10	9	8
Reserved	Reserved	Reserved	Reserved	Reserved	Reserved	Reserved	Reserved
r	r	r	r	r	r	r	r

7	6	5	4	3	2	1	0
Reserved	Reserved	Reserved	Reserved	IDL3	IDL2	IDL1	IDL0
r	r	r	r	rw*	rw*	rw*	rw*

Figure 3-48. Idle Detection Length Register

This register defines the number of minislots used by the CC for checking the duration of the network idle time between two consecutive frames in the dynamic segment. This includes the dynamic slot idle phase. Writing this register is possible only during the configuration state.

The value of IDLR depends on the values of the bit duration register ([Section 3.2.3.3.1, “Bit Duration Register \(BDR\)”](#)) and the minislot length register ([Section 3.2.3.3.12, “Minislot Length Register \(MSLR\)”](#)). It can be calculated using [Equation 3-9](#).

$$\text{IDLR} = \text{ceil}((11 * \text{BDR}) / (\text{NMLR} * \text{MSLR})). \quad \text{Eqn. 3-9}$$

The value in the register must be in the range [1:15].

3.2.3.3.36 Symbol Window Control Register (SWCTRLR)

Address 0x84

Reset 0x0

15	14	13	12	11	10	9	8
Reserved	Reserved	Reserved	Reserved	Reserved	Reserved	Reserved	Reserved
r	r	r	r	r	r	r	r

7	6	5	4	3	2	1	0
Reserved	CHB	CHA	Reserved	Reserved	Reserved	Reserved	Reserved
r	rw	rw	r	r	r	r	r

Figure 3-49. Symbol Window Control Register

This register controls the transmission of symbols in a symbol window of a communication cycle. The register may be modified during the configuration state and during normal operation.

CHB and CHA determine whether a symbol will be transmitted on channel B or channel A, respectively.

1 – Symbol transmission enabled.

0 – Symbol transmission disabled.

3.2.3.3.37 Wakeup Mechanism Control Register (WMCTRLR)

Address 0x8A

Reset 0x0

15	14	13	12	11	10	9	8
Reserved	Reserved	Reserved	Reserved	Reserved	Reserved	Reserved	Reserved
r	r	r	r	r	r	r	r

7	6	5	4	3	2	1	0
Reserved	CHB	CHA	CNT4	CNT3	CNT2	CNT1	CNT0
r	rw*	rw*	rw*	rw*	rw*	rw*	rw*

Figure 3-50. Wakeup Mechanism Control Register

This register controls the transmission of wakeup symbols. The register may be modified in the configuration state only.

CHB and CHA determine whether a wakeup symbol will be transmitted on channel B or channel A, respectively.

1 – Wakeup symbol transmission enabled.

0 – Wakeup symbol transmission disabled.

CNT[4:0] determine the number of wakeup symbols to be transmitted. The controller will transmit at least two wakeup symbols if wakeup symbol transmission is enabled.

3.2.3.3.38 Wakeup Symbol TX Idle Register (WUSTXIR)

FlexRay protocol related parameter – gdWakeupSymbolTxIdle

Address 0xEA

Reset 0x0

15	14	13	12	11	10	9	8
Reserved	Reserved	Reserved	Reserved	Reserved	Reserved	Reserved	Reserved
r	r	r	r	r	r	r	r

7	6	5	4	3	2	1	0
CNT7	CNT6	CNT5	CNT4	CNT3	CNT2	CNT1	CNT0
rw*	rw*	rw*	rw*	rw*	rw*	rw*	rw*

Figure 3-51. Wakeup Symbol TX Idle Register

This register controls the duration of the idle period of wakeup symbols. Bits CNT[7:0] determine the duration of the idle period in bit durations on the network. The register may be modified in the configuration state only.

3.2.3.3.39 Wakeup Symbol TX Low Register (WUSTXLR)

FlexRay protocol related parameter – gdWakeupSymbolTxLow

Address 0xEC

Reset 0x0

15	14	13	12	11	10	9	8
Reserved	Reserved	Reserved	Reserved	Reserved	Reserved	Reserved	Reserved
r	r	r	r	r	r	r	r

7	6	5	4	3	2	1	0
Reserved	Reserved	CNT5	CNT4	CNT3	CNT2	CNT1	CNT0
r	r	rw*	rw*	rw*	rw*	rw*	rw*

Figure 3-52. Wakeup Symbol TX Low Register

This register controls the duration of the low period of wakeup symbols. Bits CNT[5:0] determine the duration of the low period in bit durations on the network. The register may be modified only during the configuration state.

3.2.3.3.40 Listen Timeout With Noise Length Register (LNLR)

FlexRay protocol related parameter – gListenNoise

Address 0xD6

Reset undefined state

15	14	13	12	11	10	9	8
Reserved	Reserved	Reserved	Reserved	Reserved	Reserved	Reserved	Reserved
r	r	r	r	r	r	r	r

7	6	5	4	3	2	1	0
Reserved	Reserved	Reserved	CNT4	CNT3	CNT2	CNT1	CNT0
r	r	r	rw*	rw*	rw*	rw*	rw*

Figure 3-53. Listen Timeout With Noise Length Register

This register controls the duration of the listen timeout with noise. Bits CNT[4:0] determine the duration of the listen timeout as a number of communication cycles. The register may be modified in the configuration state only.

3.2.3.4 Status Registers

3.2.3.4.1 Protocol State Register (PSR)

Address 0x0C

Reset 0x0

15	14	13	12	11	10	9	8
Reserved	Reserved	Reserved	Reserved	Reserved	Reserved	Reserved	Reserved
r	r	r	r	r	r	r	r

7	6	5	4	3	2	1	0
Reserved	Reserved	Reserved	PS4	PS3	PS2	PS1	PS0
r	r	r	rh	rh	rh	rh	rh

Figure 3-54. Protocol State Register

This register is used to indicate the internal state of the CC. This register is read-only for the host. A hard reset clears the register.

Table 3-4. CC State Coding

CC State	Code (Decimal)	Slot Status Monitoring available
Configuration	0	No
Initialize Schedule	1	No
Normal Active Operation	2	Yes
Normal Passive Operation	3	Yes
Integration Consistency Check	4	Yes
Integration Listen	5	No
Coldstart Listen	21	No
Integration Coldstart Check	22	Yes
Join Coldstart	23	Yes
Coldstart Collision Resolution	24	No
Coldstart Consistency Check	25	Yes
Coldstart Gap	26	No
Wakeup	11	No

NOTE

Refer to note 2 in [Section 3.2.3.5.7, “Slot Status Counter n Register, n = \[0:7\] \(SSCnR\)”](#) for information on the MFR4200 slot status monitoring mechanisms.

3.2.3.4.2 Current Cycle Counter Value Register (CCCVR)

FlexRay protocol related parameter – vCycle

Address 0x0A

Reset 0x0

15	14	13	12	11	10	9	8
Reserved	Reserved	Reserved	Reserved	Reserved	Reserved	Reserved	Reserved
r	r	r	r	r	r	r	r

7	6	5	4	3	2	1	0
Reserved	Reserved	CCC5	CCC4	CCC3	CCC2	CCC1	CCC0
r	r	rh	rh	rh	rh	rh	rh

Figure 3-55. Current Cycle Counter Value Register

This register provides the current cycle counter value (bits CCCV[4:0]). The register is cleared by a hard reset or when leaving the configuration state. If the maximum value is reached, the counter wraps around to zero and continues counting.

The current cycle counter value is measured in communication cycles.

3.2.3.4.3 Current Macrotick Counter Value Register (CMCVR)

FlexRay protocol related parameter – vMacrotick

Address 0x08

Reset 0x0

15	14	13	12	11	10	9	8
Reserved	Reserved	CMCV13	CMCV12	CMCV11	CMCV10	CMCV9	CMCV8
r	r	rh	rh	rh	rh	rh	rh

7	6	5	4	3	2	1	0
CMCV7	CMCV6	CMCV5	CMCV4	CMCV3	CMCV2	CMCV1	CMCV0
rh	rh	rh	rh	rh	rh	rh	rh

Figure 3-56. Current Macrotick Counter Value Register

This register indicates the current cycle time in macroticks (bits CMCV[13:0]). The register is cleared by a hard reset or when leaving the configuration state. The CC increments the register during the cycle, and clears it at the start of a new cycle.

3.2.3.4.4 Offset Correction Value Register (OCVR)

FlexRay protocol related parameter – vOffsetCorrection

Address 0x32C

Reset undefined state

15	14	13	12	11	10	9	8
OCV15	OCV14	OCV13	OCV12	OCV11	OCV10	OCV9	OCV8
rh	rh	rh	rh	rh	rh	rh	rh

7	6	5	4	3	2	1	0
OCV7	OCV6	OCV5	OCV4	OCV3	OCV2	OCV1	OCV0
rh	rh	rh	rh	rh	rh	rh	rh

Figure 3-57. Offset Correction Value Register

This read-only register indicates the offset correction value, in microticks, calculated by the clock synchronization algorithm (before external offset correction and before value limitation), at the end of each communication cycle. Data in this register is presented in 2's complement form. The value in this register is valid after a communication cycle start and until its NIT start. The CC modifies OCVR during the NIT.

3.2.3.4.5 Rate Correction Value Register (RCVR)

FlexRay protocol related parameter – vRateCorrection

Address 0x32A

Reset undefined state

15	14	13	12	11	10	9	8
RCV15	RCV14	RCV13	RCV12	RCV11	RCV10	RCV9	RCV8
rh	rh	rh	rh	rh	rh	rh	rh

7	6	5	4	3	2	1	0
RCV7	RCV6	RCV5	RCV4	RCV3	RCV2	RCV1	RCV0
rh	rh	rh	rh	rh	rh	rh	rh

Figure 3-58. Rate Correction Value Register

This read-only register indicates the rate correction value, in microticks, calculated by the clock synchronization algorithm (before external rate correction and value limitation), at the end of each odd communication cycle. Data in this register is presented in 2's complement form.

3.2.3.4.6 Global Network Management Vector n Register, n = [0:5] (GNMVnR)

Address GNMV0R=0x40, GNMV1R=0x42, GNMV2R=0x44, GNMV3R=0x46, GNMV4R=0x48, GNMV5R=0x4A,
Reset 0x0

15	14	13	12	11	10	9	8
GNMV15	GNMV14	GNMV13	GNMV12	GNMV11	GNMV10	GNMV9	GNMV8
rh	rh	rh	rh	rh	rh	rh	rh

7	6	5	4	3	2	1	0
GNMV7	GNMV6	GNMV5	GNMV4	GNMV3	GNMV2	GNMV1	GNMV0
rh	rh	rh	rh	rh	rh	rh	rh

Figure 3-59. Global Network Management Vector n Register, n = [0:5]

These read-only registers hold the global network management vector. The length of the network management vector is configured by means of the NMVLR register (see [Section 3.2.3.3.28, “Network Management Vector Length Register \(NMVLR\)”](#)). The GNMVnR registers are cleared during a hard reset.

NOTE

If the NMVLR register is programmed with a value less than 12, then the remaining bytes of the GNMVnR registers (which are not used for network management vector accumulating) will remain 0's.

The global network management vector, as presented in the communication cycle x, is the OR-combination of all network management vectors received in the communication cycle x-1. The controller ensures that the value read from GNMV0R is consistent.

The mapping between the receive message buffer payload bytes and the GNMVnR registers is shown in [Table 3-5](#). (See also [Section , “Receive, receive FIFO, and transmit message buffers are accessible to the host MCU only through the active receive, active transmit, and active receive FIFO buffers.”](#).)

Table 3-5. Mapping between Receive Message Buffer Payload Bytes and GNMVnR Registers

GNMVnR	Byte	NMVectorn
GNMV0R	MSB	NMVector1
	LSB	NMVector0
GNMV1R	MSB	NMVector3
	LSB	NMVector2
...		
GNMV5R	MSB	NMVector11
	LSB	NMVector10

3.2.3.4.7 Symbol Window Status channel A Register (SWSAR)

Address 0x86
Reset 0x0

15	14	13	12	11	10	9	8
Reserved	Reserved	Reserved	Reserved	Reserved	Reserved	SYMB	CH
r	r	r	r	r	r	rh	rh
7	6	5	4	3	2	1	0
VCE	SYNCF	NULLF	SUPF	SERR	CERR	BVIOL	TXCON
rh	rh	rh	rh	rh	rh	rh	rh

Figure 3-60. Symbol Window Status Channel A Register

This register holds the symbol window status for channel A. The symbol window status is the same as a regular slot status as described in [Section 3.3.3, “Message Buffer Slot Status Vector”](#), with the addition of the SYMB flag.

SYMB — Symbol

This flag indicates the reception of a symbol in the symbol window.

0 – No symbol received.

1 – Symbol received.

TXCON — TX Conflict

This flag indicates transmission conflicts, i.e. indicates that a reception is ongoing when the controller starts transmission. This bit indicates conflicts during transmission in a symbol window.

0 – No transmission conflict detected

1 – Transmission conflict detected

Refer to [Section 3.3.3, “Message Buffer Slot Status Vector”](#) for a description of the other bits in this register.

3.2.3.4.8 Symbol Window Status Channel B Register (SWSBR)

Address 0x88

Reset 0x0

15	14	13	12	11	10	9	8
Reserved	Reserved	Reserved	Reserved	Reserved	Reserved	SYMB	CH
r	r	r	r	r	r	rh	rh

7	6	5	4	3	2	1	0
VCE	SYNCF	NULLF	SUPF	SERR	CERR	BVIOL	TXCON
rh	rh	rh	rh	rh	rh	rh	rh

Figure 3-61. Symbol Window Status Channel B Register

This register holds the symbol window status for channel B. The symbol window status is the same as a regular slot status as described in [Section 3.3.3, “Message Buffer Slot Status Vector”](#), with the addition of the SYMB flag.

SYMB — Symbol

This flag indicates the reception of a symbol in the symbol window.

0 – No symbol received.

1 – Symbol received.

TXCON — TX Conflict

This flag indicates transmission conflicts, i.e. indicates that a reception is ongoing when the controller starts transmission. This bit indicates conflicts during transmission in a symbol window.

0 – No transmission conflict detected

1 – Transmission conflict detected

Refer to [Section 3.3.3, “Message Buffer Slot Status Vector”](#) for a description of the other bits in this register.

3.2.3.4.9 Bus Guardian Status Register (BGSR)

Address 0x3A

Reset 0x0

15	14	13	12	11	10	9	8
Reserved	Reserved	Reserved	Reserved	Reserved	Reserved	Reserved	Reserved
r	r	r	r	r	r	r	r

7	6	5	4	3	2	1	0
Reserved	Reserved	Reserved	Reserved	Reserved	BGSME1	BGSME0	BGRR
r	r	r	r	r	rh	rh	rh

Figure 3-62. Bus Guardian Status Register

This register holds the bus guardian status.

BGRR — Bus Guardian Reset Request

Request to the host to reset the bus guardian.

1 – BG reset request.

0 – No BG reset request.

BGSME0 – Bus Guardian Schedule Monitoring Error Indication for channel A

Indication of a bus guardian schedule monitoring error on channel A.

1 – BGSM error on channel A.

0 – No BGSM error on channel A.

BGSME1 — Bus Guardian Schedule Monitoring Error Indication for channel B

Indication of a bus guardian schedule monitoring error on channel B.

1 – BGSM error on channel B.

0 – No BGSM error on channel B.

NOTE

If at least one of the BGSME bits is set, the BGS bit is set in the ISR0 (see [Section 3.2.3.6.6, “Interrupt Status Register 0 \(ISR0\)”](#)), and an interrupt is generated if enabled (see [Section 3.2.3.5.5, “Interrupt Enable Register 0 \(IER0\)”](#)).

3.2.3.5 Interrupt and Error Signaling Related Control Registers

3.2.3.5.1 Startup Interrupt Enable Register (SIER)

Address 0x16

Reset 0x0

15	14	13	12	11	10	9	8
Reserved	Reserved	Reserved	Reserved	Reserved	Reserved	Reserved	Reserved
r	r	r	r	r	r	r	r

7	6	5	4	3	2	1	0
Reserved	Reserved	Reserved	Reserved	CDSTPNSIE	CDSTPNIE	PLFIE	CDSTMIE
r	r	r	r	rw	rw	rw	rw

Figure 3-63. Startup Interrupt Enable Register

This register holds the interrupt enable flags related to the startup interrupt status register (see [Section 3.2.3.6.7, “Startup Interrupt Status Register \(SISR\)”](#)). The SIER register is cleared during a hard reset.

CDSTMIE — Coldstart Max Interrupt Enable

1 – Coldstart max interrupt enabled.

0 – Coldstart max interrupt disabled.

PLFIE — Plausibility Failed Interrupt Enable

1 – Plausibility failed interrupt enabled.

0 – Plausibility failed interrupt disabled.

CDSTPNIE — Coldstart Path Normal Interrupt Enable

1 – Coldstart path normal interrupt enabled.

0 – Coldstart path normal interrupt disabled.

CDSTPNSIE — Coldstart Path Noise Interrupt Enable

1 – Coldstart path noise interrupt enabled.

0 – Coldstart path noise interrupt disabled.

CDSTPNSIE — Coldstart Path Noise Interrupt Enable

1 – Coldstart path noise interrupt enabled.

0 – Coldstart path noise interrupt disabled

3.2.3.5.2 Maximum Odd Cycles Without Clock Correction Fatal Register (MOCWCFR)

FlexRay protocol related parameter – gMaxWithoutClockCorrectionFatal

Address 0xCC

Reset undefined state

15	14	13	12	11	10	9	8
MCWCF15	MCWCF14	MCWCF14	MCWCF14	MCWCF14	MCWCF14	MCWCF14	MCWCF14
rw*	rw*	rw*	rw*	rw*	rw*	rw*	rw*

7	6	5	4	3	2	1	0
MCWCF14	MCWCF14	MCWCF14	MCWCF4	MCWCF3	MCWCF2	MCWCF1	MCWCF0
rw*	rw*	rw*	rw*	rw*	rw*	rw*	rw*

Figure 3-64. Maximum Odd Cycles Without Clock Correction Fatal Register

This register holds the maximum number of odd communication cycles (double cycles) before a node enters the diagnosis stop state due to missing sync frame pairs (missing rate correction).

The register can be written only in the configuration state. If the CCFCV register value equals the MOCWCFR register value, the CC will enter the ‘red’ error state (see [Section 3.2.3.6.5, “Error Handling Level Register \(EHLR\)”](#)), and will signal this to the host by raising an interrupt.

According to the protocol specification, the value of this register lies in the range [1:15]; however, the current implementation supports values in the range [1:32767].

3.2.3.5.3 Maximum Odd Cycles Without clock Correction Passive Register (MOCWCPR)

FlexRay protocol related parameter – gMaxWithoutClockCorrectonPassive

Address 0xD8

Reset undefined state

15	14	13	12	11	10	9	8
MCWCP15	MCWCP14	MCWCP13	MCWCP12	MCWCP11	MCWCP10	MCWCP9	MCWCP8
rw*	rw*	rw*	rw*	rw*	rw*	rw*	rw*

7	6	5	4	3	2	1	0
MCWCP7	MCWCP6	MCWCP5	MCWCP4	MCWCP3	MCWCP2	MCWCP1	MCWCP0
rw*	rw*	rw*	rw*	rw*	rw*	rw*	rw*

Figure 3-65. Maximum Odd Cycles Without Clock Correction Passive Register

This register holds the maximum number of odd communication cycles (double cycles) before a node enters the passive state due to missing sync frame pairs (missing rate correction).

The register can be written only in the configuration state. If the CCFCR register value (see [Section 3.2.3.6.4, “Clock Correction Failed Counter Register \(CCFCR\)”](#)) equals the MOCWCPR register value, the CC will enter the ‘yellow’ error state (see [Section 3.2.3.6.5, “Error Handling Level Register \(EHLR\)”](#)), and will signal this to the host by raising an interrupt. According to the protocol specification,

the value of this register lies in the range [1:15]; however, the current implementation supports values in the range [1:32767].

3.2.3.5.4 Channel Status Error Counter n Register, n = [0:1] (CSECnR)

Address 0x2C, 0x2E

Reset 0x0

15	14	13	12	11	10	9	8
CNT15	CNT14	CNT13	CNT12	CNT11	CNT10	CNT9	CNT8
rh	rh	rh	rh	rh	rh	rh	rh

7	6	5	4	3	2	1	0
CNT7	CNT6	CNT5	CNT4	CNT3	CNT2	CNT1	CNT0
rh	rh	rh	rh	rh	rh	rh	rh

Figure 3-66. Channel Status Error Counter n Register, n = [0:1]

Channel status error counters CSEC0R and CSEC1R wrap around after they reach the maximum value. These registers are reset when leaving the configuration state.

CSEC0R is assigned to channel A of the CC.

CSEC1R is assigned to channel B of the CC.

The controller generates a slot status vector for:

- every static slot
- dynamic slots during which the controller receives or transmits a frame
- symbol window
- network idle time on either channel

The controller increments the corresponding channel status error counter once if any slot status error bit (bits 0–3 of the slot status vector) is set.

Channel status error counters are independent of other slot status monitoring mechanisms, i.e. message buffers (Section 3.2.3.7, “Message Buffers and FIFO Configuration Related Registers”), slot status registers (Section 3.2.3.6.8, “Slot Status n Register with n = [0:7] (SSnR)”), and slot status counters (Section 3.2.3.5.7, “Slot Status Counter n Register, n = [0:7] (SSCnR)”).

NOTE

- To determine the number of errors that occurred during a certain period of time, the host must store intermediate values of the channel status error counters.
- If a frame exceeds a slot boundary, the controller increments the channel status error counter twice, because a slot boundary violation always affects two slots.

- Refer to [Table 3-4](#) for slot status monitoring availability in different protocol states.

3.2.3.5.5 Interrupt Enable Register 0 (IER0)

Address 0x14

Reset 0x0

15	14	13	12	11	10	9	8
FATALIE	CCLRIE	MAXSYNCIE	EHLICIE	MRCEIE	SSINTIE	BGSIE	MOCEIE
rw	rw	rw	rw	rw	rw	rw	rw

7	6	5	4	3	2	1	0
TIF1IE	TIFOIE	CYCIE	RFOIE	RFNEIE	CHIERRIE	TXIE	RXIE
rw	rw	rw	rw	rw	rw	rw	rw

Figure 3-67. Interrupt Enable Register 0

Each bit in the IER0 register enables its corresponding interrupt in the ISR0 register (see [Section 3.2.3.6.6, “Interrupt Status Register 0 \(ISR0\)”](#)). Their meaning is as follows:

0 – The corresponding interrupt is disabled.

1 – The corresponding interrupt enabled.

3.2.3.5.6 Slot Status Selection n Register, n = [0:3] (SSSnR)

Address SSS0R=0x6C, SSS1R=0x6E, SSS2R=0x70, SSS3R=0x72

Reset 0x0

15	14	13	12	11	10	9	8
Reserved	Reserved	Reserved	Reserved	Reserved	ID10	ID9	ID8
r	r	r	r	r	rw	rw	rw

7	6	5	4	3	2	1	0
ID7	ID6	ID5	ID4	ID3	ID2	ID1	ID0
rw	rw	rw	rw	rw	rw	rw	rw

Figure 3-68. Slot Status Selection n Register, n = [0:3]

This set of n registers selects the static slot IDs for which the status will be provided in the SSnR registers (see [Section 3.2.3.6.8, “Slot Status n Register with n = \[0:7\] \(SSnR\)”](#)).

NOTE

SSSnR cannot be used for dynamic slots or minislots.

ID[0:10] — Slot Status Slot ID Selection

ID[0:10] select the ID of the slot to observe.

3.2.3.5.7 Slot Status Counter n Register, n = [0:7] (SSCnR)

Address SSC0R=0x4C, SSC1R=0x4E, SSC2R=0x50, SSC3R=0x52, SSC4R=0x54, SSC5R=0x56, SSC6R=0x58, SSC7R=0x5A

Reset 0x0

15	14	13	12	11	10	9	8
CNT15	CNT14	CNT13	CNT12	CNT11	CNT10	CNT9	CNT8
rh	rh	rh	rh	rh	rh	rh	rh

7	6	5	4	3	2	1	0
CNT7	CNT6	CNT5	CNT4	CNT3	CNT2	CNT1	CNT0
rh	rh	rh	rh	rh	rh	rh	rh

Figure 3-69. Slot Status Counter n Register, n = [0:7]

Slot status counters may trigger interrupts via the SSCIR register (see [Section 3.2.3.5.9, “Slot Status Counter Incrementation Register \(SSCIR\)”](#)). These interrupts may be enabled via the SSCIMR register (see [Section 3.2.3.5.10, “Slot Status Counter Interrupt Mask Register \(SSCIMR\)”](#)). Refer to [Table 3-4](#) for slot status monitoring availability in different protocol states.

The controller increments the internal slot status counter whenever the slot status provided by the protocol engine fulfills the status condition specified in the corresponding slot status counter condition register SSCnR. The internal slot status counter is not directly visible to the host. Depending on the value of bit MULTCYC of the corresponding register SSCnR (see [Section 3.2.3.5.8, “Slot Status Counter Condition n Register, n = \[0:7\] \(SSCnR\)”](#)), the controller either clears the internal slot status counter with every cycle start (MULTCYC = 0) or keeps on incrementing continuously (MULTCYC = 1).

The host always gets the value of the internal slot status counter for the previous communication cycle (MULTCYC = 0) or cycles (MULTCYC = 1), when accessing slot status counters SSCnR.

Slot status counters do not wraparound.

NOTE 1

- To clear slot status counter SSCnR, the host must reset bit MULTCYC in the corresponding slot status counter condition register SSCnR. The controller will then reset the internal slot status counter at the beginning of the following cycle, and the host will get the accumulated value of the internal slot status counter at the end of the following cycle.
- The controller clears all internal slot status counters when leaving the configuration state.
- The controller clears an internal slot status counter at the beginning of every cycle, if bit MULTCYC is 0 in the corresponding slot status counter condition register.

NOTE 2

The controller provides four independent slot status monitoring mechanisms:

- Slot status registers SSnR configured via slot status selection registers SSSnR, as described in [Section 3.2.3.6.8, “Slot Status n Register with n = \[0:7\] \(SSnR\)”](#) and [Section 3.2.3.5.6, “Slot Status Selection n Register, n = \[0:3\] \(SSSnR\)”](#).
- Channel status error counters CSEC0R and CSEC1R, as described in [Section 3.2.3.5.4, “Channel Status Error Counter n Register, n = \[0:1\] \(CSECnR\)”](#).
- Slot status information within message buffers, as described in [Section 3.3.3, “Message Buffer Slot Status Vector”](#).
- Slot status counter registers SSCnR configured via slot status counter condition registers SSCCnR as described in [Section 3.2.3.5.7, “Slot Status Counter n Register, n = \[0:7\] \(SSCnR\)”](#) and [Section 3.2.3.5.8, “Slot Status Counter Condition n Register, n = \[0:7\] \(SSCCnR\)”](#).
- Refer to [Table 3-4](#) for slot status monitoring availability in different protocol states.

3.2.3.5.8 Slot Status Counter Condition n Register, n = [0:7] (SSCCnR)

Address SSCC0R=0x5C, SSCC1R=0x5E, SSCC2R=0x60, SSCC3R=0x62, SSCC4R=0x64, SSCC5R=0x66, SSCC6R=0x68, SSCC7R=0x6A
Reset 0x0

15	14	13	12	11	10	9	8
Reserved	Reserved	Reserved	Reserved	Reserved	CHCFG1	CHCFG0	MULTCYC
r	r	r	r	r	rw	rw	rw

7	6	5	4	3	2	1	0
VCES	SYNCF5	NULLFS	SUPFS	SSCM3	SSCM2	SSCM1	SSCM0
rw	rw	rw	rw	rw	rw	rw	rw

Figure 3-70. Slot Status Counter Condition n Register, n = [0:7]

Each of these registers serves as condition to detect if the corresponding slot status counter (see [Section 3.2.3.5.7, “Slot Status Counter n Register, n = \[0:7\] \(SSCnR\)”](#)) is to be incremented.

SSCMx, x = [0:3] — Slot Status Mask

A binary AND operation is performed on this 4-bit vector and the status of each slot-channel tuple that is not booked for transmission in the static part of the communication cycle.

If the result is 0, and conditions for null frame selection (NULLS), sync frame selection (SYNCS), startup frame selection (SUPFS), and valid communication element selection (VCES) are not met, the counter will not be incremented for that slot-channel tuple.

NULLFS — NULL Frame Selection

This register is used to restrict counting to received null frames only.

- 0 – The slot status counter is incremented independently of the null frame indication bit.
- 1 – The slot status counter is incremented only when a syntactically correct null frame is received.

SYNCFS — SYNC Frame Selection

This register can be used to restrict counting to received sync frames only.

- 0 – The slot status counter can be incremented independently of the sync frame bit.
- 1 – The slot status counter can be incremented only when a syntactically correct sync frame is received.

SUPFS — StartUP Frame Selection

This register can be used to restrict counting to received startup frames only.

- 0 – The slot status counter can be incremented independently of the startup bit.
- 1 – The slot status counter can be incremented only when a syntactically correct startup frame is received.

VCES — Valid Communication Element Selection

This register can be used to restrict counting to semantically valid frames only.

- 0 – The slot status counter can be incremented for semantically valid and invalid frames.
- 1 – The slot status counter can be incremented only when a semantically valid frame is received.

MULTCYC — Multiple Cycle

This bit determines if the slot status counter reflects the values of multiple communication cycles or of the previous communication cycle only. Note that MULTCYC may be written during normal operation, but its value must not be modified by the host during the NIT.

- 0 – The internal slot status counter starts at 0 at the beginning of every communication cycle, and SSCnR reflects the values of the previous communication cycle.
- 1 – The internal slot status counter is not reset to 0 at the beginning of every communication cycle; this allows counting of specific slot status conditions over several communication cycles. SSCnR reflects the accumulated values counted in previous communication cycles.

CHCFG1, CHCFG0 — Channel Configuration

These bits determine the channel assignment for slot status counters SSCnR, as defined in [Table 3-6](#).

Table 3-6. Channel Configuration for SSCnR

CHCFG1	CHCFG0	Meaning
0	0	Count for channel A
0	1	Count for channel B

Table 3-6. Channel Configuration for SSCnR

CHCFG1	CHCFG0	Meaning
1	0	Count for both channels only once even if the counting condition is fulfilled for both channels
1	1	Count for both channels independently. If the counting condition is fulfilled for both channels, count twice.

NOTE

Slot status counting is supported for the static segment only.

3.2.3.5.9 Slot Status Counter Incrementation Register (SSCIR)

Address 0x28

Reset 0x0

15	14	13	12	11	10	9	8
0	0	0	0	0	0	0	0
r	r	r	r	r	r	r	r

7	6	5	4	3	2	1	0
SSCIR7	SSCIR6	SSCIR5	SSCIR4	SSCIR3	SSCIR2	SSCIR1	SSCIR0
rwh	rwh	rwh	rwh	rwh	rwh	rwh	rwh

Figure 3-71. Slot Status Counter Incrementation Register

This register contains one bit, SSCIR_n, for each slot status counter SSC_nR (see Section 3.2.3.5.7, “Slot Status Counter n Register, n = [0:7] (SSC_nR)”). Bit SSCIR_n is set when the slot status counter SSC_nR is incremented. The register is reset on leaving the configuration state. The host may clear individually each bit in register SSCIR by writing a ‘1’ to it.

3.2.3.5.10 Slot Status Counter Interrupt Mask Register (SSCIMR)

Address 0x2A

Reset 0x0

15	14	13	12	11	10	9	8
Reserved	Reserved	Reserved	Reserved	Reserved	Reserved	Reserved	Reserved
r	r	r	r	r	r	r	r

7	6	5	4	3	2	1	0
SSCIMR7	SSCIMR6	SSCIMR5	SSCIMR4	SSCIMR3	SSCIMR2	SSCIMR1	SSCIMR0
rw	rw	rw	rw	rw	rw	rw	rw

Figure 3-72. Slot Status Counter Interrupt Mask Register

Via this register, the host may enable individually each bit in the SSCIR (see [Section 3.2.3.5.9, “Slot Status Counter Incrementation Register \(SSCIR\)”](#)) to trigger the interrupt SSINT in the ISR0 (see [Section 3.2.3.6.6, “Interrupt Status Register 0 \(ISR0\)”](#)).

- 1 – If the corresponding bit in register SSCIR is set, trigger the interrupt SSINT.
- 0 – Ignore the corresponding bit in register SSCIR; do not trigger an interrupt.

3.2.3.6 Interrupt and Error Signaling Related Status Registers

3.2.3.6.1 Receive Buffer Interrupt Vector Register (RBIVECR)

Address 0x24

Reset 0x0

15	14	13	12	11	10	9	8
Reserved	Reserved	Reserved	Reserved	Reserved	Reserved	Reserved	Reserved
r	r	r	r	r	r	r	r
7	6	5	4	3	2	1	0
Reserved	Reserved	RBIVEC5	RBIVEC4	RBIVEC3	RBIVEC2	RBIVEC1	RBIVEC0
r	r	rh	rh	rh	rh	rh	rh

Figure 3-73. Receive Buffer Interrupt Vector Register

This register indicates the lowest numbered receive message buffer that has its interrupt status flag (IFLG) and its interrupt enable (IENA) bits set. The register is cleared by a hard reset or by leaving the configuration state.

NOTE

- After an IFLG has been set or cleared, the CC updates the RBIVECR register after 1 μ T.
- The RBIVECR register contains valid data only if the RXIF bit is set (see [Section 3.2.3.6.6, “Interrupt Status Register 0 \(ISR0\)”](#)).
- If there are no IFLG bits set for any receive message buffers that have their IENA bit set, then the CC sets the RBIVECR register to 0x0000 (IFLG, IENA — see [Section 3.2.3.7.2, “Message Buffer Control, Configuration and Status n Register, n = \[0:58\] \(BUFCSnR\)”](#)).

3.2.3.6.2 Transmit Buffer Interrupt Vector Register (TBIVECR)

Address 0x26
Reset 0x0

15	14	13	12	11	10	9	8
Reserved	Reserved	Reserved	Reserved	Reserved	Reserved	Reserved	Reserved
r	r	r	r	r	r	r	r

7	6	5	4	3	2	1	0
Reserved	Reserved	TBIVEC5	TBIVEC4	TBIVEC3	TBIVEC2	TBIVEC1	TBIVEC0
r	r	rh	rh	rh	rh	rh	rh

Figure 3-74. Transmit Buffer Interrupt Vector Register

This register indicates the lowest numbered transmit message buffer that has its interrupt status flag (IFLG) and its interrupt enable (IENA) bits set. A hard reset or leaving the configuration state clear the register.

NOTE

- After an IFLG has been set or cleared, the CC updates the TBIVECR register after 1 μ T.
- The TBIVECR register contains valid data only if the TXIF bit is set (see [Section 3.2.3.6.6, “Interrupt Status Register 0 \(ISR0\)”](#)).
- If there are no IFLG bits set for any transmit message buffers that have their IENA bit set, then the CC sets the TBIVECR register to 0x0000 (IFLG, IENA — see [Section 3.2.3.7.2, “Message Buffer Control, Configuration and Status n Register, n = \[0:58\] \(BUFCSnR\)”](#)).

3.2.3.6.3 CHI Error Register (CHIER)

Address 0x12
Reset 0x0

15	14	13	12	11	10	9	8
ILLADR	NMENF	NMEFTS	SPLME	MDPLE	BULE	EFLE	FBLE
rwh	rwh	rwh	rwh	rwh	rwh	rwh	rwh

7	6	5	4	3	2	1	0
TBLE	RBLE	Reserved	CCPBLE	BB	Reserved	IRE	FLE
rwh	rwh	r	rwh	rwh	r	rwh	rwh

Figure 3-75. CHI Error Register

This register holds CHI status flags. The host clears any status bit in the CHIER by writing a '1' to it; writing a '0' does not change the bit state. The CC sets a status bit in the CHIER again, when it detects the condition for that bit. If the host and the CC try to write the CHIER register at the same time, the CC write

operation has the higher priority. If the host tries to clear a set error flag in the CHIER register, while the CC at the same time sets this bit, the error flag will remain set. A hard reset clears the register.

NOTE

When any error is processed by the CC, and indicated in the CHIER register, the CC raises an interrupt, if configured to do so by means of the ISR0 and IER0 bits, and continues operation without changing state.

FLE — Frame Lost Error

This error occurs if the host has locked a receive message buffer, and two semantically valid frames for that buffer are received during this locked time. The first frame will be lost.

1 – Frame lost error detected.

0 – No frame lost error detected.

IRE — Illegal Reconfiguration Error

This error appears if the host tries to reconfigure a dynamic transmit message buffer to a static one. The reconfiguration, in that case, is ignored by the CC.

1 – Illegal reconfiguration error detected.

0 – No illegal reconfiguration error detected.

BB — Buffer Busy

This bit is set if the host tries to lock a message buffer that is locked by the CC for internal operations. The CC, in that case, does not grant access to the message buffer through the locking mechanism.

1 – Buffer busy detected.

0 – No buffer busy detected.

Buffer Locking Errors:

CCPBLE — CC Part Buffer of a Double Transmit Message Buffer Lock Error

This error is raised if the host tries to lock a CC part buffer of a double transmit message buffer. The CC, in that case, does not grant access to the CC part buffer of a double transmit message buffer through the locking mechanism.

1 – CCPBLE detected.

0 – No CCPBLE detected.

RBLE — Receive Message Buffers Locking Error

This error appears if the host tries to lock more than 1 receive message buffer. The CC in that case does not grant access to the buffer through the locking mechanism.

1 – RBLE detected.

0 – No RBLE detected.

TBLE — Transmit Message Buffers Locking Error

This error appears if the host tries to lock more than one transmit message buffer. The CC, in that case, does not grant access to the buffer through the locking mechanism.

1 – TBLE detected.

0 – No TBLE detected.

FBLE — FIFO Message Buffer Lock Error

This error appears if the host tries to lock a FIFO message buffer not through message buffer 0. The CC, in that case, does not grant access to the message buffer through the locking mechanism.

1 – FBLE detected.

0 – No FBLE detected.

EFLE — Empty FIFO Lock Error

This error appears if the host tries to lock an empty FIFO. The CC, in that case, does not grant access to the FIFO through the locking mechanism.

1 – EFLE detected.

0 – No EFLE detected.

BULE — Unlocked Message Buffer Lock Error

This error appears if the host tries to access an unlocked message buffer through any active message buffer. In that case, the host write operations to an active message buffer are ignored, and read operations return 0's.

1 – BULE detected.

0 – No BULE detected.

Other Error Indicators:

MDPLE — Maximum Dynamic Payload Length Exceeded Error

This error appears if the payload length written into a dynamic segment transmit message buffer **PayloadLength** field is greater than the maximum payload length dynamic configured in the maximum payload length dynamic register MPLDR (see [Section 3.2.3.3.16, “Maximum Payload Length Dynamic Register \(MPLDR\)”](#)). In that case, the wrong payload length is ignored.

1 – MDPLE detected.

0 – No MDPLE detected.

SPLME — Static Payload Length Mismatch Error

This error appears if the payload length written into a static segment transmit message buffer is not equal to the static payload length configured within the static payload length register SPLR (see [Section 3.2.3.3.11, “Static Payload Length Register \(SPLR\)”](#)). In that case, the wrong payload length is ignored.

1 – SPLME detected.

0 – No SPLME detected.

NMEFTS — Network Management Error Frame Too Short

This error appears if the payload length value of a received message is not big enough to hold the complete configured NM vector. However, the received part of the NM vector is used for the NM vector update (see [Section 3.2.3.4.6, “Global Network Management Vector n Register, n = \[0:5\] \(GNMVnR\)”](#)).

1 – NMEFTS detected.

0 – No NMEFTS detected.

NMENF — Network Management Error Null Frame

This error appears if a received message with an NM bit set has a null frame bit set. In that case, the GNMVnR registers are not updated.

1 – NMENF detected.

0 – No NMENF detected.

ILLADR — Illegal Address

This error appears if the host tries to perform a byte access (a write access, if the HCS12 interface is selected) or an unaligned word access.

If the HCS12 interface is selected (see chapter [Section 3.7, “Host Controller Interfaces”](#)), and this error appears, the CC presents the data value 0x0000 to the host and indicates an ILLADR error.

NOTE

The address space from 0x0400 to 0x1FFF in the MFR4200 memory map is reserved. Reading this address space results in data 0x0000, while writing does not change the memory. Reading or writing this address space will set the ILLADR bit.

1 – ILLADR detected.

0 – No ILLADR detected.

3.2.3.6.4 Clock Correction Failed Counter Register (CCFCR)

FlexRay Protocol Related Parameter – vClockCorrectionFailed

Address 0x326

Reset undefined state

15	14	13	12	11	10	9	8
Reserved	Reserved	Reserved	Reserved	Reserved	Reserved	Reserved	Reserved
r	r	r	r	r	r	r	r

7	6	5	4	3	2	1	0
Reserved	Reserved	Reserved	Reserved	OWCC3	OWCC2	OWCC1	OWCC0
r	r	r	r	rh	rh	rh	rh

Figure 3-76. Clock Correction Failed Counter Register

This register holds the clock correction failed counter. This counter is reset when a node enters normal active operation. It is incremented by one at the end of any odd communication cycle, when either the missing offset correction error or the missing rate correction error, or both, are active. The counter is reset to zero at the end of an odd communication cycle if neither the offset correction failed error nor the rate correction failed error is active. The counter is not incremented after it reaches the maximum odd communication cycles without clock correction programmed value (see [Section 3.2.3.5.2, “Maximum Odd Cycles Without Clock Correction Fatal Register \(MOCWCFR\)”](#)). The host has read-only access to this register.

3.2.3.6.5 Error Handling Level Register (EHLR)

Address 0x328

Reset undefined state

15	14	13	12	11	10	9	8
Reserved	Reserved	Reserved	Reserved	Reserved	Reserved	Reserved	Reserved
r	r	r	r	r	r	r	r

7	6	5	4	3	2	1	0
Reserved	Reserved	Reserved	Reserved	Reserved	Reserved	EHL1	EHL0
r	r	r	r	r	r	rh	rh

Figure 3-77. Error Handling Level Register

This register holds the current value of the error handling level. Error handling levels are defined in [Table 3-7](#):

Table 3-7. Error Handling Level Coding

EHL1	EHL0	Error Handling Level	CC state
0	0	Green level	Normal Active
0	1	Yellow level	Normal Passive
1	0	Red level	Diagnosis Stop
1	1	Not used	–

3.2.3.6.6 Interrupt Status Register 0 (ISR0)

Address 0x0E

Reset 0x0

15	14	13	12	11	10	9	8
FATAL	CCLR	MAXSYNC	EHLC	MRCE	SSINT	BGS	MOCE
rwh	rwh	rwh	rwh	rwh	rwh	rwh	rwh
7	6	5	4	3	2	1	0
TIF1	TIF0	CYCIF	RFOIF	RFNEIF	CHIERRIF	TXIF	RXIF
rwh	rwh	rwh	rwh	rwh	rwh	rwh	rwh

Figure 3-78. Interrupt Status Register 0

This register indicates the occurrence of interrupt events. Together with IER0 (see [Section 3.2.3.5.5, “Interrupt Enable Register 0 \(IER0\)”](#)), it allows the module to operate in a polled or interrupt driven system.

NOTE

- The host clears any status bit in the ISR0 by writing a '1' to the bit. Writing a '0' does not change the bit state.
- The CC sets a status bit of the ISR0 again when it detects the condition for that bit.
- The host must resolve the conditions causing the RFNEIF, CHIERRIF, TXIF, and RXIF bits to be asserted, as these flags are updated automatically by the CC, depending on conditions related to these flags. If the host does not resolve the conditions that lead to these flags being asserted, the CC ignores the host's clear operation for these bits and the bits remain asserted.
- If the host and the CC try to write the ISR0 register at the same time, the CC operation has the higher priority.

Every flag has an associated interrupt enable flag in interrupt enable register 0. The ISR0 register is cleared by a hard reset or by leaving the configuration state.

RXIF — Receive Interrupt Flag

This bit is set when any of the enabled ($IENAn = 1$) receive message buffers or the receive FIFO has successfully received a frame. Sources of this interrupt are set IFLG bits (see [Section 3.4.1, “Message Buffer Control, Configuration and Status Register”](#)) of the corresponding message buffers. If RXIE is set (see [Section 3.2.3.5.5, “Interrupt Enable Register 0 \(IER0\)”](#)), a receive interrupt remains pending while the RXIF flag is set.

- 1 – At least one receive message buffer is full.
- 0 – All receive message buffers are empty.

TXIF — Transmit Interrupt Flag

This read-only bit is set when any of the enabled ($IENAn = 1$) transmit message buffers is empty ($IFLG = 1$). Sources of this interrupt are set IFLG bits (see [Section 3.4.1, “Message Buffer Control, Configuration and Status Register”](#)) of the corresponding message buffers. If TXIE is set (see [Section 3.2.3.5.5, “Interrupt Enable Register 0 \(IER0\)”](#)), an interrupt remains pending while this flag is set.

- 1 – At least one transmit message buffer is empty.
- 0 – All transmit message buffers are full.

CHIERRIF — CHI Error Interrupt Flag

This bit is set when a CHI error is detected. Sources of this interrupt are CHI errors in the CHIER register (see [Section 3.2.3.6.3, “CHI Error Register \(CHIER\)”](#)). If CHIERRIF is set, an interrupt remains pending while this flag is set.

- 1 – A CHI error was detected.
- 0 – No CHI error was detected.

RFNEIF — Receive FIFO Not Empty Interrupt Flag

This bit is set when the receive FIFO is not empty. If enabled, a FIFO not empty interrupt remains pending while this flag is set. The flag will be cleared if the FIFO is empty and message buffer 0 is unlocked. The CC sets this flag when the FIFO is not empty.

- 1 – Receive FIFO is not empty.
- 0 – Receive FIFO is empty.

RFOIF — Receive FIFO Overrun Interrupt Flag

This bit is set when a receive FIFO overrun occurs. If enabled, an interrupt remains pending while this flag is set.

- 1 – A receive FIFO overrun has been detected.
- 0 – No receive FIFO overrun has occurred.

CYCIF — Cycle Start Interrupt Flag

This bit is set when a communication cycle starts. If enabled, an interrupt remains pending while this flag is set.

- 1 – A communication cycle started.
- 0 – No communication cycle started.

TIF0/TIF1 — Timer Interrupt Flag 0/1

This bit is set when:

- the result of the timer 0/1 interrupt calculation, based on the cycle base and repetition fields of the timer interrupt configuration register 0 (see [Section 3.2.3.9.1, “Timer Interrupt Configuration Register 0 Cycle Set \(TICR0CS\)”](#)), matches the current cycle counter value in the CCCV register (see [Section 3.2.3.4.2, “Current Cycle Counter Value Register \(CCCV\)”](#));
- and the macrotick offset programmed in the timer interrupt configuration register 0 (see [Section 3.2.3.9.1, “Timer Interrupt Configuration Register 0 Cycle Set \(TICR0CS\)”](#)) matches the current macrotick value from CMCVR (see [Section 3.2.3.4.3, “Current Macrotick Counter Value Register \(CMCVR\)”](#)).

If enabled, an interrupt remains pending while this flag is set.

- 1 – Timer 0/1 has reached the limit.
- 0 – Timer 0/1 has not reached the limit.

NOTE

After a hard reset, timer interrupt configuration registers are cleared. The CC indicates timers interrupts (ISR0 = 0x00C0) immediately after the hard reset, as the protocol engine provides cycle time and cycle counter values equal to zero during the whole configuration state. No interrupt is indicated to the host, as the interrupt enable register IER0 is also 0 after a hard reset.

MOCE — Missing Offset Correction error

This bit is set if an insufficient number of measurements is available for offset correction at the end of the communication cycle (even and odd).

- 1 – Insufficient number of measurements available for offset correction.
- 0 – Sufficient number of measurements available for offset correction

BGS — Bus Guardian Status

This bit indicates bus guardian schedule monitoring errors on channel A and/or channel B. The host may read the bus guardian status register BGSR (see [Section 3.2.3.4.9, “Bus Guardian Status Register \(BGSR\)”](#)) to determine on which channel the error occurred. The host may reset BGS by writing a ‘1’.

- 1 – Bus guardian schedule monitoring error.
- 0 – No bus guardian schedule monitoring error

SSINT — Slot Status Interrupt

This bit indicates that at least one slot status counter register SSCnR (see [Section 3.2.3.5.7, “Slot Status Counter n Register, n = \[0:7\] \(SSCnR\)”](#)) that is enabled as an interrupt source via slot status counter interrupt mask register SSCIMR (see [Section 3.2.3.5.10, “Slot Status Counter Interrupt Mask Register \(SSCIMR\)”](#)) has been incremented.

- 1 – At least one slot status counter that is enabled as an interrupt source has been incremented.
- 0 – No slot status counter that is enabled as an interrupt source has been incremented.

MRCE — Missing Rate Correction error

This bit is set if an insufficient number of measurement pairs is available for rate correction at the end of the odd communication cycle.

- 1 – Insufficient number of measurement pairs available for rate correction
- 0 – Sufficient number of measurement pairs available for rate correction

EHLC — Error Handling Level Changed/ Startup Interrupt detected

This signal indicates, to the host, changes to the error handling level.

- 1 – Error handling level has changed.
- 0 – Error handling level has not changed.

MAXSYNC — Max Sync Frames Detected

The controller sets this bit when more than the configured maximum number of sync frames (see [Section 3.2.3.3.5, “Maximum Sync Frames Register \(MSFR\)”](#)) are detected within a single cycle. In this case, the controller is not able to capture all time difference measurements.

- 1 – More than the configured maximum number of sync frames have been received.
- 0 – Not more than the configured maximum number of sync frames have been received.

CCLR — Clock Correction Limit Reached

This bit is set if offset or rate calculation reaches the threshold as configured in registers MOCR and MRCCR (see [Section 3.2.3.3.24, “Maximum Offset Correction Register \(MOCR\)”](#) and [Section 3.2.3.3.25, “Maximum Rate Correction Register \(MRCCR\)”](#)).

- 1 – Offset or rate calculation has reached the limit.
- 0 – Offset and rate correction are within the limit.

FATAL — Fatal Error

This bit is set if an illegal condition is detected in the protocol state machine; this can be caused by illegal configuration. In this as, the controller goes into the diagnosis stop state immediately.

- 1 – Fatal error detected.

0 – No fatal error detected.

3.2.3.6.7 Startup Interrupt Status Register (SISR)

Address 0x10

Reset 0x0

15	14	13	12	11	10	9	8
Reserved	Reserved	Reserved	Reserved	Reserved	Reserved	Reserved	Reserved
r	r	r	r	r	r	r	r

7	6	5	4	3	2	1	0
Reserved	Reserved	Reserved	Reserved	CDSTPNSIF	CDSTPNIF	PLFIF	CDSTMIF
r	r	r	r	rwh	rwh	rwh	rwh

Figure 3-79. Startup Interrupt Status Register

This register holds the interrupt flags related to the startup procedure. All flags are read/write for the host. Each flag has an associated interrupt enable flag in the startup interrupt enable register (see [Section 3.2.3.5.1, “Startup Interrupt Enable Register \(SIER\)”](#)). The SISR register is cleared during a hard reset or when leaving the configuration state.

The host clears a status bit in the SISR by writing a '1' to it. Writing a '0' does not change the bit state. The CC sets a status bit in the SISR again when it detects the condition for that bit. If the host and the CC try to access the SISR register at the same time, the CC operation has the higher priority.

CDSTMIF — Coldstart Max Interrupt Flag

This error signal is set if the maximum number of allowed retries of a coldstarting CC (CSMR programmed value – see [Section 3.2.3.3.26, “Coldstart Maximum Register \(CSMR\)”](#)) is reached. That is, if the CSMR register is programmed with the value N, the CC sets the CDSTMIF bit after the Nth retry has failed. If enabled, an interrupt remains pending while this flag is set.

1 – Coldstart Maximum value has been reached.

0 – Coldstart Maximum value has not been reached.

PLFIF — Plausibility Failed Interrupt Flag

This error signal is set if the consistency check of the local CC within the startup sequence failed, i.e. the number of received valid startup frames is less than required. If enabled, an interrupt remains pending while this flag is set.

1 – A Plausibility Check of the local CC within the startup sequence failed.

0 – A Plausibility Check of the local CC within the startup sequence did not fail.

CDSTPNSIF — Coldstart Path Noise Interrupt Flag

This signal is set if the CC has entered startup via the coldstart noise path. This indicates that the CC tried to start the network. If enabled, an interrupt remains pending while this flag is set.

1 – The startup has been entered via the coldstart noise path.

0 – The startup has not been entered via the coldstart noise path.

CDSTPNIF — Coldstart Path Normal Interrupt Flag

This signal is set if the CC has entered the startup via the normal coldstart path. This indicates that the CC tried to start the network. If enabled, an interrupt is pending while this flag is set.

1 – Startup has been entered via the normal coldstart path.

0 – Startup has not been entered via the normal coldstart path.

3.2.3.6.8 Slot Status n Register with n = [0:7] (SSnR)

Address SS0R=0x74, SS1R=0x76, SS2R=0x78, SS3R=0x7A, SS4R=0x7C, SS5R=0x7E, SS6R=0x80, SS7R=0x82
Reset 0x0

15	14	13	12	11	10	9	8
VCE_B	SYNCF_B	NULLF_B	SUPF_B	SERR_B	CERR_B	BVIOL_B	TXCON_B
rh	rh	rh	rh	rh	rh	rh	rh

7	6	5	4	3	2	1	0
VCE_A	SYNCF_A	NULLF_A	SUPF_A	SERR_A	CERR_A	BVIOL_A	TXCON_A
rh	rh	rh	rh	rh	rh	rh	rh

Figure 3-80. Slot Status n Register, n = [0:7]

Each of these registers holds the status of the slot specified in the corresponding slot status selection register SSSnR for both channel A and channel B. The suffices “_A” and “_B” indicate whether the slot status is valid for channel A or channel B, respectively. For a detailed description of the slot status flags, refer to [Section 3.3.3, “Message Buffer Slot Status Vector”](#).

The controller provides a pair of slot status registers for each monitored slot with the first register being assigned to even communication cycles, and the second to odd communication cycles, as shown in [Table 3-8](#).

The controller clears the slot status registers SSnR (see [Section 3.2.3.6.8, “Slot Status n Register with n = \[0:7\] \(SSnR\)”](#)) when leaving the configuration state.

NOTE

- Refer to [Table 3-4](#) for slot status monitoring availability in different protocol states.
- The slot status of slot n is updated within the first macrotick of slot n+1.

- Empty slots exhibit the slot status 0x00 for both channels, because the slot status registers SSnR do not include the slot status channel bit.

Table 3-8. Mapping between SSSnR and SSnR

Slot Status Selection Register	Even communication cycle		Odd communication cycle	
	Channel A (low byte)	Channel B (high byte)	Channel A (low byte)	Channel B (high byte)
SSS0R	SS0R	SS0R	SS1R	SS1R
SSS1R	SS2R	SS2R	SS3R	SS3R
SSS2R	SS4R	SS4R	SS5R	SS5R
SSS3R	SS6R	SS6R	SS7R	SS7R

3.2.3.6.9 Odd Sync Frame ID n Register, n = [0:15] (OSFIDnR)

Address OSFID0R=0x3E0 ... OSFID15R=0x3FE

Reset undefined state

15	14	13	12	11	10	9	8
Reserved	Reserved	Reserved	Reserved	Reserved	ID10	ID9	ID8
r	r	r	r	r	rh	rh	rh

7	6	5	4	3	2	1	0
ID7	ID6	ID5	ID4	ID3	ID2	ID1	ID0
rh	rh	rh	rh	rh	rh	rh	rh

Figure 3-81. Odd Sync Frame ID n Register, n = [0:15]

These registers hold the frame IDs of all sync frames received in odd communication cycles and used for clock synchronization. The CC does not change the odd ID values from the end of the static part in the odd cycle to the beginning of the NIT in the even communication cycle.

NOTE

If a CC is configured to send sync frames (see [Section 3.2.3.3.29, “Sync Frame Register \(SYNCFR\)”](#)), the CC will store its sync frame ID in register OSFID0R.

3.2.3.6.10 Even Sync Frame ID n Register, n = [0:15] (ESFIDnR)

Address EID0R=0x380 ... EID15R=0x39E

Reset undefined state

15	14	13	12	11	10	9	8
Reserved	Reserved	Reserved	Reserved	Reserved	ID10	ID9	ID8
r	r	r	r	r	rh	rh	rh

7	6	5	4	3	2	1	0
ID7	ID6	ID5	ID4	ID3	ID2	ID1	ID0
rh	rh	rh	rh	rh	rh	rh	rh

Figure 3-82. Even Sync Frame ID n Register, n = [0:15]

These registers hold the slot IDs of all sync frames received in even communication cycles and used for clock synchronization. The CC does not change the even ID values from the end of the static part in the even cycle to the beginning of the NIT in the odd communication cycle.

NOTE

If a CC is configured to send sync frames (see [Section 3.2.3.3.29, “Sync Frame Register \(SYNCFR\)”](#)), each time the CC clears the EMCR or OMCR, it:

- initializes the ESFID0R (or OSFID0R) with its sync frame ID,
- increments EMCR or OMCR,
- initializes EMA0R and EMB0R or OMA0R and EMB0R with the following value:

$$\text{NMLR} * \text{SSAPOR} - \text{TSSLR} * \text{BDR} - \max(\text{DCAR}, \text{DCBR}) - 4$$

Eqn. 3-10

3.2.3.6.11 Odd Measurement Channel A n Register, n = [0:15] (OMAnR)

Address OMA0R=0x3A0 ... OMA15R=0x3BE

Reset undefined state

15	14	13	12	11	10	9	8
OMA15	OMA14	OMA13	OMA12	OMA11	OMA10	OMA9	OMA8
rh	rh	rh	rh	rh	rh	rh	rh

7	6	5	4	3	2	1	0
OMA7	OMA6	OMA5	OMA4	OMA3	OMA2	OMA1	OMA0
rh	rh	rh	rh	rh	rh	rh	rh

Figure 3-83. Odd Measurement Channel A n Register, n = [0:15]

These registers hold the sync frame arrival time measured in microticks relative to the slot start boundary. Registers OMA0R to OMA15R contain all measurement values from channel A for the odd communication cycle.

3.2.3.6.12 Odd Measurement Channel B n Register, n = 0:15] (OMBnR)

Address OMB0R=0x3C0 ... OMB15R=0x3DE

Reset undefined state

15	14	13	12	11	10	9	8
OMB15	OMB14	OMB13	OMB12	OMB11	OMB10	OMB9	OMB8
rh	rh	rh	rh	rh	rh	rh	rh

7	6	5	4	3	2	1	0
OMB7	OMB6	OMB5	OMB4	OMB3	OMB2	OMB1	OMB0
rh	rh	rh	rh	rh	rh	rh	rh

Figure 3-84. Odd Measurement Channel B n Register, n = [0:15]

These registers hold the sync frame arrival time measured in microticks relative to the slot start boundary. Registers OMB0R to OMB15R contain all measurement values from channel B for the odd communication cycle.

3.2.3.6.13 Even Measurement Channel A n Register, n = [0:15] (EMAnR)

Address EMA0R=0x340 ... EMA15R=0x35E

Reset undefined state

15	14	13	12	11	10	9	8
EMA15	EMA14	EMA13	EMA12	EMA11	EMA10	EMA9	EMA8
rh	rh	rh	rh	rh	rh	rh	rh

7	6	5	4	3	2	1	0
EMA7	EMA6	EMA5	EMA4	EMA3	EMA2	EMA1	EMA0
rh	rh	rh	rh	rh	rh	rh	rh

Figure 3-85. Even Measurement Channel A n Register, n = [0:15]

These registers hold the sync frame arrival time measured in microticks relative to the slot start boundary. Registers EMA[0:15]R contain all measurement values from channel A for the even communication cycle.

3.2.3.6.14 Even Measurement Channel B n Register, n = [0:15] (EMBnR)

Address EMB0R=0x360 ... EMB15R=0x37E

Reset undefined state

15	14	13	12	11	10	9	8
EMB15	EMB14	EMB13	EMB12	EMB11	EMB10	EMB9	EMB8
rh	rh	rh	rh	rh	rh	rh	rh

7	6	5	4	3	2	1	0
EMB7	EMB6	EMB5	EMB4	EMB3	EMB2	EMB1	EMB0
rh	rh	rh	rh	rh	rh	rh	rh

Figure 3-86. Even Measurement Channel B n Register, n = [0:15]

These registers hold the sync frame arrival time measured in microticks relative to the slot start boundary. Registers EMB[0:15]R contain all measurement values from channel B for the even communication cycle.

NOTE

To get the time difference based on the expected time reference point, one must subtract the nominal action point offset in microticks, the frame start sequence length and the delay compensation according to the formula below:

$$\text{Time difference} = (\text{EMAnR, EMBnR, OMAAnR, or OMBnR}) - \text{NMLR} * \text{SSAPOR} - \text{TSSLR} * \text{BDR} - \max(\text{DCAR,DCBR}) - 4$$

Eqn. 3-11

As the transmission start sequence length is given in bits, it must be converted to μT by multiplying it by the bit duration. As the channel information is not available for the list of sync frame arrival times, the CC standardizes the values based on the channel with the larger delay compensation value; thereby, the frame arrival time is always positive.

A sync frame arrival time of 0 in one of the measurement registers denotes an invalid time difference. For example, if, in a given slot, only a sync frame on channel A has been received, the corresponding EMBnR will hold the value 0.

3.2.3.6.15 Even Measurement Counter Register (EMCR)

Address 0x33C

Reset undefined state

15	14	13	12	11	10	9	8
Reserved	Reserved	Reserved	Reserved	Reserved	Reserved	Reserved	Reserved
r	r	r	r	r	r	r	r

7	6	5	4	3	2	1	0
Reserved	Reserved	Reserved	Reserved	EMC3	EMC2	EMC1	EMC0
r	r	r	r	rh	rh	rh	rh

Figure 3-87. Even Measurement Counter Register

The EMCR and OMCR are described in the following section.

3.2.3.6.16 Odd Measurement Counter Register (OMCR)

Address 0x33E

Reset undefined state

15	14	13	12	11	10	9	8
Reserved	Reserved	Reserved	Reserved	Reserved	Reserved	Reserved	Reserved
r	r	r	r	r	r	r	r

7	6	5	4	3	2	1	0
Reserved	Reserved	Reserved	Reserved	OMC3	OMC2	OMC1	OMC0
r	r	r	r	rh	rh	rh	rh

Figure 3-88. Odd Measurement Counter Register

The EMCR and OMCR hold the number of valid sync frames received during the static segment of an even or odd cycle, respectively. If sync frame filtering is enabled, only sync frames that have passed the sync frame rejection and/or acceptance filters (see [Section 3.2.3.8.3, “Sync Frame Rejection Filter Register \(SYNFRFR\)”](#) and [Section 3.2.3.8.1, “Sync Frame Acceptance Filter Value Register \(SYNFAFVR\)”](#)) are considered. The EMCR and OMCR registers hold the number of valid measurements in the measurement tables (see [Section 3.2.3.6.9, “Odd Sync Frame ID n Register, n = \[0:15\] \(OSFIDnR\)”](#) and [Section 3.2.3.6.11, “Odd Measurement Channel A n Register, n = \[0:15\] \(OMAnR\)”](#)). For example, if the value of EMCR is two, then two valid sync frames are available for clock sync calculations; the remaining fourteen values in the measurement table for the even cycle are invalid and may have undefined content.

The EMCR and OMCR counters are incremented each time, when a valid sync frame has been received on at least one of the channels.

EMCR and OMCR are reset when the CC enters the initialize schedule and coldstart collision resolution states. In the normal active state and the normal passive state, EMCR is reset in the NIT of the odd cycle, and OMCR is reset at the end of the even cycle. If the node is a non sync node, EMCR and OMCR are

reset to zero. If the node is a sync node, EMCR and OMCR are reset to 1, as a sync node considers its own sync frames as zero values in the measurement tables.

3.2.3.7 Message Buffers and FIFO Configuration Related Registers

3.2.3.7.1 FIFO Size Register (FSIZR)

Address 0x18

Reset 0x0

15	14	13	12	11	10	9	8
Reserved	Reserved	Reserved	Reserved	Reserved	Reserved	Reserved	Reserved
r	r	r	r	r	r	r	r
7	6	5	4	3	2	1	0
Reserved	Reserved	FSIZ5	FSIZ4	FSIZ3	FSIZ2	FSIZ1	FSIZ0
r	r	rw*	rw*	rw*	rw*	rw*	rw*

Figure 3-89. FIFO Size Register

This register is used to configure the FIFO. The number of message buffers assigned to the receive FIFO, starting from message buffer 0, can be selected. Writing the FSIZR register is possible only during the configuration state.

Table 3-9. FIFO Size

FSIZ[5:0]	FIFO Size
000000	No FIFO is defined
000001	only message buffer 0
000010	message buffer 0...message buffer 1
000011	message buffer 0...message buffer 2
...	...
111001	message buffer 0...message buffer 56
111010	message buffer 0...message buffer 57
others	message buffer 0...message buffer 58

3.2.3.7.2 Message Buffer Control, Configuration and Status n Register, n = [0:58] (BUFCSnR)

Address BUFCS0R=0x200, BUFCS1R=0x204, ..., BUFCS57R=0x2E4, BUFCS58R=0x2E8.

BUFCSnR=0x200 + 0x4*dec2hex(n)

Reset IFLG, IENA, CFG and VALID bits are reset to 0, others – in undefined state

15	14	13	12	11	10	9	8
VALID	TT	CCFE	BT	DATUPD	CHB	CHA	BUFCMT
*	*	*	*	*	*	*	*

7	6	5	4	3	2	1	0
Reserved	LOCK	Reserved	Reserved	IENA	IFLG	Reserved	CFG
r	*	r	r	*	*	r	*

Figure 3-90. Message Buffer Control, Configuration and Status n Register, n = [0:58]

For a description of these registers and the bit access scheme, see [Section 3.4.1, “Message Buffer Control, Configuration and Status Register”](#).

3.2.3.7.3 Active Transmit Buffer Frame ID Register (ATBFRID)

Address 0x180

Reset undefined state

15	14	13	12	11	10	9	8
R*	PP	NFI	SYNC	STARTUP	ID10	ID9	ID8
rw	rw*	r	r	r	rw*	rw*	rw*

7	6	5	4	3	2	1	0
ID7	ID6	ID5	ID4	ID3	ID2	ID1	ID0
rw*	rw*	rw*	rw*	rw*	rw*	rw*	rw*

Figure 3-91. Active Transmit Buffer Frame ID Register

For a description of this register and the bit access scheme, refer to [Section 3.5, “Message Buffer Handling and Operations”](#).

3.2.3.7.4 Active Transmit Buffer Cycle Counter and Payload Length Register (ATBCCPLR)

Address 0x182

Reset undefined state

15	14	13	12	11	10	9	8
Reserved	Reserved	CYCL_CNT5	CYCL_CNT4	CYCL_CNT3	CYCL_CNT2	CYCL_CNT1	CYCL_CNT0
r	r	r*	r*	r*	r*	r*	r*

7	6	5	4	3	2	1	0
Reserved	LEN6	LEN5	LEN4	LEN3	LEN2	LEN1	LEN0
r	rw*	rw*	rw*	rw*	rw*	rw*	rw*

Figure 3-92. Active Transmit Buffer Cycle Counter and Payload Length Register

NOTE

The host may read the CYCL_CNT[5:0] bits but, as those bits are not updated by the CC, they will be in an undefined state.

For a description of this register and the bit access scheme, refer to [Section 3.5, “Message Buffer Handling and Operations”](#).

3.2.3.7.5 Active Transmit Buffer Header CRC Register (ATBCRCR)

Address 0x184

Reset undefined state

15	14	13	12	11	10	9	8
Reserved	Reserved	Reserved	Reserved	Reserved	HCRC10	HCRC9	HCRC8
r	r	r	r	r	rw*	rw*	rw*

7	6	5	4	3	2	1	0
HCRC7	HCRC6	HCRC5	HCRC4	HCRC3	HCRC2	HCRC1	HCRC0
rw*	rw*	rw*	rw*	rw*	rw*	rw*	rw*

Figure 3-93. Active Transmit Buffer Header CRC Register

For a description of this register and the bit access scheme, refer to [Section 3.5, “Message Buffer Handling and Operations”](#).

3.2.3.7.6 Active Transmit Buffer Data n Register, n = [0:15] (ATBDATANR)

Address ATBDATA0R=0x186 ... ATBDATA15R=0x1A4

Reset undefined state

15	14	13	12	11	10	9	8
DATA(2n+1)15	DATA(2n+1)14	DATA(2n+1)13	DATA(2n+1)12	DATA(2n+1)11	DATA(2n+1)10	DATA(2n+1)9	DATA(2n+1)8
rw	rw	rw	rw	rw	rw	rw	rw

7	6	5	4	3	2	1	0
DATA(2n)7	DATA(2n)6	DATA(2n)5	DATA(2n)4	DATA(2n)3	DATA(2n)2	DATA(2n)1	DATA(2n)0
rw	rw	rw	rw	rw	rw	rw	rw

Figure 3-94. Active Transmit Buffer Data n Register, n = [0:15]

For a description of these registers, refer to [Section 3.5, “Message Buffer Handling and Operations”](#).

3.2.3.7.7 Active Transmit Buffer Message Buffer Slot Status Vector Register (ATBMBSSVR)

Address 0x1A6

Reset undefined state

15	14	13	12	11	10	9	8
Reserved	Reserved	Reserved	Reserved	Reserved	Reserved	Reserved	CH
r	r	r	r	r	r	r	r

7	6	5	4	3	2	1	0
VCE	SYNCF	NULLF	SUPF	SERR	GERR	BVIOL	TXCON
r	r	r	r	r	r	r	rh

Figure 3-95. Active Transmit Buffer Message Buffer Slot Status Vector Register

For a description of this register, refer to [Section 3.5, “Message Buffer Handling and Operations”](#).

3.2.3.7.8 Active Receive Buffer Frame ID Register (ARBFRID)

Address 0x140

Reset undefined state

15	14	13	12	11	10	9	8
R*	PP	NFI	SYNC	STARTUP	ID10	ID9	ID8
rh	rh	rh	rh	rh	rw*	rw*	rw*

7	6	5	4	3	2	1	0
ID7	ID6	ID5	ID4	ID3	ID2	ID1	ID0
rw*	rw*	rw*	rw*	rw*	rw*	rw*	rw*

Figure 3-96. Active Receive Buffer Frame ID Register

For a description of this register, refer to [Section 3.5, “Message Buffer Handling and Operations”](#).

3.2.3.7.9 Active Receive Buffer Cycle Counter and Payload Length Register (ARBCCPLR)

Address 0x142

Reset undefined state

15	14	13	12	11	10	9	8
Reserved	Reserved	CYCL_CNT5	CYCL_CNT4	CYCL_CNT3	CYCL_CNT2	CYCL_CNT1	CYCL_CNT0
r	r	rh	rh	rh	rh	rh	rh

7	6	5	4	3	2	1	0
Reserved	LEN6	LEN5	LEN4	LEN3	LEN2	LEN1	LEN0
r	rh	rh	rh	rh	rh	rh	rh

Figure 3-97. Active Receive Buffer Cycle Counter and Payload Length Register

For a description of this register, refer to [Section 3.5, “Message Buffer Handling and Operations”](#).

3.2.3.7.10 Active Receive Buffer Header CRC Register (ARBCRCR)

Address 0x144

Reset undefined state

15	14	13	12	11	10	9	8
Reserved	Reserved	Reserved	Reserved	Reserved	HCRC10	HCRC9	HCRC8
r	r	r	r	r	rh	rh	rh

7	6	5	4	3	2	1	0
HCRC7	HCRC6	HCRC5	HCRC4	HCRC3	HCRC2	HCRC1	HCRC0
rh	rh	rh	rh	rh	rh	rh	rh

Figure 3-98. Active Receive Buffer Header CRC Register

For a description of this register, refer to [Section 3.5, “Message Buffer Handling and Operations”](#).

3.2.3.7.11 Active Receive Buffer Data n Register, n = [0:15] (ARBDATAnR)

Address ARBDATA0R=0x146 ... ARBDATA15R=0x164

Reset undefined state

15	14	13	12	11	10	9	8
DATA(2n+1)15	DATA(2n+1)14	DATA(2n+1)13	DATA(2n+1)12	DATA(2n+1)11	DATA(2n+1)10	DATA(2n+1)9	DATA(2n+1)8
rh	rh	rh	rh	rh	rh	rh	rh

7	6	5	4	3	2	1	0
DATA(2n)7	DATA(2n)6	DATA(2n)5	DATA(2n)4	DATA(2n)3	DATA(2n)2	DATA(2n)1	DATA(2n)0
rh	rh	rh	rh	rh	rh	rh	rh

Figure 3-99. Active Receive Buffer Data n Register, n = [0:15]

For a description of these registers, refer to [Section 3.5, “Message Buffer Handling and Operations”](#).

3.2.3.7.12 Active Receive Buffer Message Buffer Slot Status Vector Register (ARMBSSVR)

Address 0x166

Reset undefined state

15	14	13	12	11	10	9	8
Reserved	Reserved	Reserved	Reserved	Reserved	Reserved	Reserved	CH
r	r	r	r	r	r	r	r

7	6	5	4	3	2	1	0
VCE	SYNCF	NULLF	SUPF	SERR	CERR	BVIOL	TXCON
rh	rh	rh	rh	rh	rh	rh	r

Figure 3-100. Active Receive Buffer Message Buffer Slot Status Vector Register

For a description of this register, refer to [Section 3.5, “Message Buffer Handling and Operations”](#).

3.2.3.7.13 Active FIFO Buffer Frame ID Register (AFBFRID)

Address 0x100

Reset undefined state

15	14	13	12	11	10	9	8
R*	PP	NFI	SYNC	STARTUP	ID10	ID9	ID8
rh	rh	rh	rh	rh	rh	rh	rh

7	6	5	4	3	2	1	0
ID7	ID6	ID5	ID4	ID3	ID2	ID1	ID0
rh	rh	rh	rh	rh	rh	rh	rh

Figure 3-101. Active FIFO Buffer Frame ID Register

For a description of this register, refer to [Section 3.5, “Message Buffer Handling and Operations”](#).

3.2.3.7.14 Active FIFO Buffer Cycle Counter and Payload Length Register (AFBCCPLR)

Address 0x102

Reset undefined state

15	14	13	12	11	10	9	8
Reserved	Reserved	CYCL_CNT5	CYCL_CNT4	CYCL_CNT3	CYCL_CNT2	CYCL_CNT1	CYCL_CNT0
r	r	rh	rh	rh	rh	rh	rh

7	6	5	4	3	2	1	0
Reserved	LEN6	LEN5	LEN4	LEN3	LEN2	LEN1	LEN0
r	rh	rh	rh	rh	rh	rh	rh

Figure 3-102. Active FIFO Buffer Cycle Counter and Payload Length Register

For a description of this register, refer to [Section 3.5, “Message Buffer Handling and Operations”](#).

3.2.3.7.15 Active FIFO Buffer Header CRC Register (AFBCRCR)

Address 0x104

Reset undefined state

15	14	13	12	11	10	9	8
Reserved	Reserved	Reserved	Reserved	Reserved	HCRC10	HCRC9	HCRC8
r	r	r	r	r	rh	rh	rh

7	6	5	4	3	2	1	0
HCRC7	HCRC6	HCRC5	HCRC4	HCRC3	HCRC2	HCRC1	HCRC0
rh	rh	rh	rh	rh	rh	rh	rh

Figure 3-103. Active FIFO Buffer Header CRC Register

For a description of this register, refer to [Section 3.5, “Message Buffer Handling and Operations”](#).

3.2.3.7.16 Active FIFO Buffer Data n Register, n = [0:15] (AFBDATANR)

Address ARFBDATA0R=0x106 ... ARFBDATA15R=0x124

Reset undefined state

15	14	13	12	11	10	9	8
DATA(2n+1)15	DATA(2n+1)14	DATA(2n+1)13	DATA(2n+1)12	DATA(2n+1)11	DATA(2n+1)10	DATA(2n+1)9	DATA(2n+1)8
rh	rh	rh	rh	rh	rh	rh	rh

7	6	5	4	3	2	1	0
DATA(2n)7	DATA(2n)6	DATA(2n)5	DATA(2n)4	DATA(2n)3	DATA(2n)2	DATA(2n)1	DATA(2n)0
rh	rh	rh	rh	rh	rh	rh	rh

Figure 3-104. Active FIFO Buffer Data n Register, n = [0:15]

For a description of these registers, refer to [Section 3.5, “Message Buffer Handling and Operations”](#).

3.2.3.7.17 Active FIFO Buffer Message Buffer Slot Status Vector Register (AFBMBSSVR)

Address 0x126

Reset undefined state

15	14	13	12	11	10	9	8
Reserved	Reserved	Reserved	Reserved	Reserved	Reserved	Reserved	CH
r	r	r	r	r	r	r	r

7	6	5	4	3	2	1	0
VCE	SYNCF	NULLF	SUPF	SERR	CERR	BVIOL	TXCON
rh	rh	rh	rh	rh	rh	rh	r

Figure 3-105. Active FIFO Buffer Message Buffer Slot Status Vector Register

For a description of this register, refer to [Section 3.5, “Message Buffer Handling and Operations”](#).

3.2.3.8 Filtering Related Registers

3.2.3.8.1 Sync Frame Acceptance Filter Value Register (SYNFAFVR)

Address 0xF0

Reset undefined state

15	14	13	12	11	10	9	8
Reserved	Reserved	Reserved	Reserved	Reserved	SYNFAFV10	SYNFAFV9	SYNFAFV8
r	r	r	r	r	rw*	rw*	rw*

7	6	5	4	3	2	1	0
SYNFAFV7	SYNFAFV6	SYNFAFV5	SYNFAFV4	SYNFAFV3	SYNFAFV2	SYNFAFV1	SYNFAFV0
rw*	rw*	rw*	rw*	rw*	rw*	rw*	rw*

Figure 3-106. Sync Frame Acceptance Filter Value Register

If ENSYNFF bit is set (see Section 3.2.3.2.1, “Module Configuration Register 0 (MCR0)”), every valid sync frame with the identifier ID must fulfill the following condition before its arrival time measurement values can be used for the clock synchronization.

An identifier is accepted when:

$$(\text{NOT}((\text{ID XOR SynFAFV}) \text{ AND SynFAFM}) \text{ AND NOT}(\text{ID} == \text{SynFRF})) == \text{TRUE} \quad \text{Eqn. 3-12}$$

This register may be written only in the configuration state.

3.2.3.8.2 Sync Frame Acceptance Filter Mask Register (SYNFAFMR)

Address 0xEE

Reset undefined state

15	14	13	12	11	10	9	8
Reserved	Reserved	Reserved	Reserved	Reserved	SYNFAFM10	SYNFAFM9	SYNFAFM8
r	r	r	r	r	rw*	rw*	rw*

7	6	5	4	3	2	1	0
SYNFAFM7	SYNFAFM6	SYNFAFM5	SYNFAFM4	SYNFAFM3	SYNFAFM2	SYNFAFM1	SYNFAFM0
rw*	rw*	rw*	rw*	rw*	rw*	rw*	rw*

Figure 3-107. Sync Frame Acceptance Filter Mask Register

SYNFAFM[10:0]

0 – This bit position is “don't care” for acceptance.

1 – This bit of the identifier must be identical to the corresponding bit in the acceptance value, for it to be accepted by the sync frame acceptance filter.

This register may be written only in the configuration state.

3.2.3.8.3 Sync Frame Rejection Filter Register (SYNFRFR)

Address 0xF2

Reset undefined state

15	14	13	12	11	10	9	8
Reserved	Reserved	Reserved	Reserved	Reserved	SYNFRF10	SYNFRF9	SYNFRF8
r	r	r	r	r	rw	rw	rw

7	6	5	4	3	2	1	0
SYNFRF7	SYNFRF6	SYNFRF5	SYNFRF4	SYNFRF3	SYNFRF2	SYNFRF1	SYNFRF0
rw	rw	rw	rw	rw	rw	rw	rw

Figure 3-108. Sync Frame Rejection Filter Register

If the ENSYNFF bit is set (see [Section 3.2.3.2.1, “Module Configuration Register 0 \(MCR0\)”](#)), this register is used to identify a sync frame ID whose arrival time measurement values are to be rejected for clock synchronization. Note that this register can be written at any time by the host, unlike SYNFAFMR and SYNFAFVR (see [Section 3.2.3.8.2, “Sync Frame Acceptance Filter Mask Register \(SYNFAFMR\)”](#) and [Section 3.2.3.8.1, “Sync Frame Acceptance Filter Value Register \(SYNFAFVR\)”](#)).

NOTE

To ensure correct operation of the CC, the host should update this register only during the NIT.

3.2.3.8.4 Cycle Counter Filter n Register, n = [0:58] (CCFnR)

Address CCF0R=0x202, CCF1R=0x206, ..., CCF57R=0x2E6, CCF58R=0x2EA.

CCFnR=0x202 + 0x4*dec2hex(n)

Reset undefined state

15	14	13	12	11	10	9	8
Reserved	Reserved	CCM5	CCM4	CCM3	CCM2	CCM1	CCM0
r	r	rw*	rw*	rw*	rw*	rw*	rw*

7	6	5	4	3	2	1	0
Reserved	Reserved	CCV5	CCV4	CCV3	CCV2	CCV1	CCV0
r	r	rw*	rw*	rw*	rw*	rw*	rw*

Figure 3-109. Cycle Counter Filter n Register, n = [0:58]

Each cycle counter filter register is related to an appropriate message buffer: CCF0R to message buffer 0, CCF1R to message buffer 1, ..., CCF58R to message buffer 58. (For more information, refer to [Section , “Receive, receive FIFO, and transmit message buffers are accessible to the host MCU only through the active receive, active transmit, and active receive FIFO buffers.”](#)).

CCV[0:5] — Cycle Count Value n Bit[0:5]

These bits determine the cycle count value to be used for the cycle filtering.

CCM[0:5] — Cycle Count Mask n Bit[0:5]

These bits define the mask used in the filtering process.

0 – This bit of the cycle counter is not used for filtering.

1 – This bit of the cycle counter is used for filtering.

For a description of the read and write character of each bit-field, refer to [Section 3.4.1, “Message Buffer Control, Configuration and Status Register”](#) and [Section 3.4.2, “Message Buffer Filter Registers”](#).

3.2.3.8.5 FIFO Acceptance Filter Message ID Value Register (FAFMIDVR)

Address 0x1C

Reset 0x0

15	14	13	12	11	10	9	8
FMDAFV15	FMDAFV14	FMDAFV13	FMDAFV12	FMDAFV11	FMDAFV10	FMDAFV9	FMDAFV8
rw*	rw*	rw*	rw*	rw*	rw*	rw*	rw*
7	6	5	4	3	2	1	0
FMDAFV7	FMDAFV6	FMDAFV5	FMDAFV4	FMDAFV3	FMDAFV2	FMDAFV1	FMDAFV0
rw*	rw*	rw*	rw*	rw*	rw*	rw*	rw*

Figure 3-110. FIFO Acceptance Filter Message ID Value Register

FMDAFV[0:15]

These bit-fields define the FIFO message ID filter value, for comparison with the message ID field of received frames. It defines the acceptable pattern value of the message ID to be received. These bits may be written only in the configuration state.

3.2.3.8.6 FIFO Acceptance Filter Message ID Mask Register (FAFMIDMR)

Address 0x1E

Reset 0x0

15	14	13	12	11	10	9	8
FMDAFM15	FMDAFM14	FMDAFM13	FMDAFM12	FMDAFM11	FMDAFM10	FMDAFM9	FMDAFM8
rw*	rw*	rw*	rw*	rw*	rw*	rw*	rw*
7	6	5	4	3	2	1	0
FMDAFM7	FMDAFM6	FMDAFM5	FMDAFM4	FMDAFM3	FMDAFM2	FMDAFM1	FMDAFM0
rw*	rw*	rw*	rw*	rw*	rw*	rw*	rw*

Figure 3-111. FIFO Acceptance Filter Message ID Mask Register

FMDAFM[0:15]

These bit-fields define the mask for the FIFO message ID filter.

0 – This bit in the message ID field of a received frame is not considered for acceptance filtering.

1 – This bit in the message ID field of a received frame is used for the acceptance filtering.

These bits may be written only in the configuration state.

3.2.3.8.7 FIFO Acceptance/Rejection Filter Channel Register (FAFCHR)

Address 0x1A

Reset 0x0

15	14	13	12	11	10	9	8
Reserved	Reserved	Reserved	Reserved	Reserved	Reserved	Reserved	Reserved
r	r	r	r	r	r	r	r
7	6	5	4	3	2	1	0
Reserved	Reserved	Reserved	Reserved	Reserved	Reserved	FCHBAFV	FCHAAFV
r	r	r	r	r	r	rw*	rw*

Figure 3-112. FIFO Acceptance/Rejection Filter Channel Register

FCHAAFV, FCHBAFV

These are FIFO channel filtering value bits. They define the channel from which the received frame will be accepted or rejected. These bits may be written only in the configuration state.

Table 3-10. FIFO Channel Filtering Configuration

FCHAAFV	FCHBAFV	Receive message buffer Store valid Rx frame
1	1	Frame received on both channels are accepted or rejected
1	0	Frame received on channel A is accepted or rejected
0	1	Frame received on channel B is accepted or rejected
0	0	Ignore frame

3.2.3.8.8 FIFO Rejection Filter Frame ID Value Register (FRFFIDVR)

Address 0x20
Reset 0x0

15	14	13	12	11	10	9	8
Reserved	Reserved	Reserved	Reserved	Reserved	FFIDRFV10	FFIDRFV9	FFIDRFV8
r	r	r	r	r	rw*	rw*	rw*

7	6	5	4	3	2	1	0
FFIDRFV7	FFIDRFV6	FFIDRFV5	FFIDRFV4	FFIDRFV3	FFIDRFV2	FFIDRFV1	FFIDRFV0
rw*	rw*	rw*	rw*	rw*	rw*	rw*	rw*

Figure 3-113. FIFO Rejection Filter Frame ID Value Register

FFIDRFV[0:10]

This field contains the FIFO frame ID rejection filter value, for comparison with frame ID fields of received frames. It defines the acceptable pattern value of the frame ID to be rejected. These bits may be written only in the configuration state.

3.2.3.8.9 FIFO Rejection Filter Frame ID Mask Register (FRFFIDMR)

Address 0x22
Reset 0x0

15	14	13	12	11	10	9	8
Reserved	Reserved	Reserved	Reserved	Reserved	FFIDRFM10	FFIDRFM9	FFIDRFM8
r	r	r	r	r	rw*	rw*	rw*

7	6	5	4	3	2	1	0
FFIDRFM7	FFIDRFM6	FFIDRFM5	FFIDRFM4	FFIDRFM3	FFIDRFM2	FFIDRFM1	FFIDRFM0
rw*	rw*	rw*	rw*	rw*	rw*	rw*	rw*

Figure 3-114. FIFO Rejection Filter Frame ID Mask Register

FFIDRFM[0:10]

These bit-fields indicate the mask for the FIFO Rejection frame ID filter.

0 – This bit of the internal slot ID (when a frame was received) is not considered for the rejection filtering.

1 – This bit of the internal slot ID (when a frame was received) is used for the rejection filtering.

These bits may be written only in the configuration state.

3.2.3.9 Timer Related Registers

The CC provides two timers with timer interrupt configuration registers for setting interrupts for specific points of global time. Each timer contains two parameters:

1. **Cycle Set:** A 9-bit register is used to specify in which set of communication cycles the interrupt will occur. It consists of two fields, the base cycle [b] and the cycle repetition [c]. The set of cycle numbers where the interrupt is to generated is determined from these two fields using the formula:

$$b + n \cdot 2^c \quad (n = 0, 1, 2, \dots) \quad \text{Eqn. 3-13}$$

where:

- b is a 6-bit cycle number used to identify the initial value for generating the cycle set.
- c is a 3-bit value used to determine a constant repetition factor to be added to the base cycle (c = 0 ... 6)
- b must be smaller than 2^c :

$$b < 2^c. \quad \text{Eqn. 3-14}$$

2. **Macrotick Offset:** This 16-bit value is the macrotick offset from the beginning of the cycle in which the interrupt is to occur. The interrupt occurs at this offset for each cycle in the interrupt cycle set.

3.2.3.9.1 Timer Interrupt Configuration Register 0 Cycle Set (TICR0CS)

Address 0x30

Reset 0x0

15	14	13	12	11	10	9	8
Reserved	Reserved	Reserved	Reserved	Reserved	CR2	CR1	CR0
r	r	r	r	r	rw	rw	rw
7	6	5	4	3	2	1	0
Reserved	Reserved	BCT5	BCT4	BCT3	BCT2	BCT1	BCT0
r	r	rw	rw	rw	rw	rw	rw

Figure 3-115. Timer Interrupt Configuration Register 0 Cycle Set

This register holds base cycle and cycle repetition values for timer 0.

A hard reset clears the register.

BCT[0:5]

Base cycle value for timer 0.

CR[0:2]

Cycle repetition value for timer 0.

3.2.3.9.2 Timer Interrupt Configuration Register 0 Macrotick Offset (TICR0MO)

Address 0x32

Reset 0x0

15	14	13	12	11	10	9	8
MO15	MO14	MO13	MO12	MO11	MO10	MO9	MO8
rw	rw	rw	rw	rw	rw	rw	rw

7	6	5	4	3	2	1	0
MO7	MO6	MO5	MO4	MO3	MO2	MO1	MO0
rw	rw	rw	rw	rw	rw	rw	rw

Figure 3-116. Timer Interrupt Configuration Register 0 Macrotick Offset

This register holds the macrotick offset value for timer 0. A hard reset clears the register.

3.2.3.9.3 Timer Interrupt Configuration Register 1 Cycle Set (TICR1CS)

Address 0x34

Reset 0x0

15	14	13	12	11	10	9	8
Reserved	Reserved	Reserved	Reserved	Reserved	CR2	CR1	CR0
r	r	r	r	r	rw	rw	rw

7	6	5	4	3	2	1	0
Reserved	Reserved	BCT5	BCT4	BCT3	BCT2	BCT1	BCT0
r	r	rw	rw	rw	rw	rw	rw

Figure 3-117. Timer Interrupt Configuration Register 1 Cycle Set

This register holds base cycle and cycle repetition values for timer 1.

A hard reset clears the register.

BCT[0:5]

Base cycle value for timer 1.

CR[0:2]

Cycle repetition value for timer 1.

3.2.3.9.4 Timer Interrupt Configuration Register 1 Macrotick Offset (TICR1MO)

Address 0x36
Reset 0x0

15	14	13	12	11	10	9	8
MO15	MO14	MO13	MO12	MO11	MO10	MO9	MO8
rw	rw	rw	rw	rw	rw	rw	rw

7	6	5	4	3	2	1	0
MO7	MO6	MO5	MO4	MO3	MO2	MO1	MO0
rw	rw	rw	rw	rw	rw	rw	rw

Figure 3-118. Timer Interrupt Configuration Register 1 High

The timer interrupt configuration register 1 macrotick offset holds the macrotick offset value for timer 1. A hard reset clears the register.

3.3 Message Buffer

Receive, receive FIFO, and transmit message buffers are accessible to the host MCU only through the active receive, active transmit, and active receive FIFO buffers.

3.3.1 Message Buffer Layout

The layout shown in below, apply to transmit, receive buffer, and FIFO buffers.

Table 3-11. Receive Message Buffer Layout

	15	14	13	12	11	10	9	8	7	6	5	4	3	2	1	0
0	R* RO	PP RO	NFI RO	SYNC RO	START UP RO	Frame ID (11 bits) RO_NOWR_CS										
1	R NU		Cycle Count (6 bits) RO					R NU		PayloadLength (7 bits) RO						
2	R NU					Header CRC (11 bits) RO										
3	Message ID1/Data1/NMVector1 RO							Message ID0/Data0/NMVector0 RO								
4	Data3/NMVector3 RO							Data2/NMVector2 RO								
5	Data5/NMVector5 RO							Data4/NMVector4 RO								
6	Data7/NMVector7 RO							Data6/NMVector6 RO								
7	Data9/NMVector9 RO							Data8/NMVector8 RO								
8	Data11/NMVector11 RO							Data10/NMVector10 RO								
9	Data13 RO							Data12 RO								
...	... RO							... RO								
18	Data31 RO							Data30 RO								
19	Message Buffer Slot Status Vector RO															

Table 3-12. Receive FIFO Message Buffer Layout

	15	14	13	12	11	10	9	8	7	6	5	4	3	2	1	0
0	R* RO	PP RO	NFI RO	SYNC RO	START UP RO	Frame ID (11 bits) RO										
1	R NU		Cycle Count (6 bits) RO					R NU		PayloadLength (7 bits) RO						
2	R NU					Header CRC (11 bits) RO										
3	Message ID1/Data1/NMVector1 RO							Message ID0/Data0/NMVector0 RO								
4	Data3/NMVector3 RO							Data2/NMVector2 RO								
5	Data5/NMVector5 RO							Data4/NMVector4 RO								
6	Data7/NMVector7 RO							Data6/NMVector6 RO								
7	Data9/NMVector9 RO							Data8/NMVector8 RO								
8	Data11/NMVector11 RO							Data10/NMVector10 RO								
9	Data13 RO							Data12 RO								
...	... RO							... RO								
18	Data31 RO							Data30 RO								
19	Message Buffer Slot Status Vector RO															

Table 3-13. Transmit Message Buffer Layout

	15	14	13	12	11	10	9	8	7	6	5	4	3	2	1	0
0	R* WR	PP TX_CS_NO	NFI NU	SYNC NU	START UP NU	Frame ID (11 bits) TX_CS_NO										
1	R NU		Cycle Count (6 bits) NU					R NU		PayloadLength (7 bits) TX_CS_NO						
2	R NU					Header CRC (11 bits) TX_CS_NO										
3	Message ID1/Data1/NMVector1 WR							Message ID0/Data0/NMVector0 WR								
4	Data3/NMVector3 WR							Data2/NMVector2 WR								
5	Data5/NMVector5 WR							Data4/NMVector4								
6	Data7/NMVector7 WR							Data6/NMVector6 WR								
7	Data9/NMVector9 WR							Data8/NMVector8 WR								
8	Data11/NMVector11 WR							Data10/NMVector10 WR								
9	Data13 WR							Data12 WR								
...	... WR							... WR								
18	Data31 WR							Data30 WR								
19	Message Buffer Slot Status Vector RO															

NOTE

The host cannot access the CC part of a double transmit message buffer. CC raises a locking error if the host tries to lock the CC part of a double transmit message buffer.

Where:

RO_NO/WR_CS	Host read access; host write access during the configuration state only
TX_CS_NO	Host read access; host write access: – during the configuration state for all transmit message buffers – during normal mode of operation for buffers configured for the dynamic segment of the communication cycle (read-only access for static segment buffers)
RO	Host read-only access
WR	Host read/write access
NU	Reserved or read-only bits not used by the CC during operation

The size of the data field in the MFR4200 is limited to 32 bytes.

Table 3-14. Mapping between Buffer Layout and Active Receive/Transmit/FIFO Message Buffers

Message Buffer Layout						Active FIFO/Receive/Transmit Message Buffers Register	
R*	P	N	SYN	STAR	Frame ID (11 bits)	Active FIFO/Receive/Transmit Buffer Frame ID Register	
		FI	C	T UP			
R	Cycle Count (6 bits)			R	PayloadLength (7 bits)	Active FIFO/Receive/Transmit Buffer Cycle Counter and Payload Length Register	
R			Header CRC (11 bits)			Active FIFO/Receive/Transmit Buffer Header CRC Register	
Message ID1/Data1/NMVector1				Message ID0/Data0/NMVector0		Active FIFO/Receive/Transmit Buffer Data 0 Register	
Data3/NMVector3				Data2/NMVector2		Active FIFO/Receive/Transmit Buffer Data 1 Register	
Data5/NMVector5				Data4/NMVector4		Active FIFO/Receive/Transmit Buffer Data 2 Register	
Data7/NMVector7				Data6/NMVector6		Active FIFO/Receive/Transmit Buffer Data 3 Register	
Data9/NMVector9				Data8/NMVector8		Active FIFO/Receive/Transmit Buffer Data 4 Register	
Data11/NMVector11				Data10/NMVector10		Active FIFO/Receive/Transmit Buffer Data 5 Register	
Data13				Data12		Active FIFO/Receive/Transmit Buffer Data 6 Register	
...				
Data31				Data30		Active FIFO/Receive/Transmit Buffer Data 15 Register	
Message Buffer Slot Status Vector						Active FIFO/Receive/Transmit Buffer Message Buffer Slot Status Vector Register	

3.3.2 Message Buffer Field Descriptions

3.3.2.1 ID[10:0] — Frame ID Field

Each transmit and receive message buffer and the FIFO buffer contains a frame ID field. This field is interpreted differently for receive message buffers, transmit message buffers, and the receive FIFO.

Receive message buffers:

The Frame ID field contains a frame ID filtering value. A received frame is stored in the first receive message buffer with a filter matching the received frame ID. The channel and cycle counter receive filtering criteria must also be met.

Transmit message buffers:

The frame ID field in the message buffer is used to determine the appropriate slot for frame transmission. The frame is transmitted in the time slot corresponding to the frame ID, provided the channel and cycle counter criteria are also met.

Receive FIFO message buffer:

The frame ID field in each element of the receive FIFO buffer stores a received frame ID value, if the frame is accepted by the FIFO acceptance filter and not rejected by the FIFO rejection filter and if there is no matching dedicated receive message buffer. For more information on FIFO filters, refer to [Section 3.2.3.8, “Filtering Related Registers”](#))

3.3.2.2 R* — Reserved Bit

The reserved bit R* corresponds to the reserved bit in the header of the FlexRay frame. The controller transmits that bit within the frame header. This bit must be cleared by the host for PS V1.9/V2.0 compliant operation.

3.3.2.3 R — Reserved Bits

These bits are reserved for future use and have no correlation with the R* bit.

3.3.2.4 PP — Payload Preamble Bit

The payload preamble bit indicates that a static frame’s payload data hold a network management vector, and that a dynamic frame’s payload data hold a message ID, respectively.

3.3.2.5 NFI — Null Frame Indication Bit

The null frame indication bit shows the value of the null frame indication flag for received frames stored in message receive/FIFO buffers. This bit has no function for transmit message buffers. The NULLF bit, described in [Section 3.3.3, “Message Buffer Slot Status Vector”](#), indicates the reception of a null frame on the physical layer.

NOTE

During the transition from the hard reset to the configuration state, the CC initializes the NFI bits of all buffers to ‘0’. In the normal passive and active states, the CC receives but does not store null frames. Therefore, after the first reception and storage of a valid receive frame’s header and payload data to a receive message/FIFO buffer, the CC sets the NFI bit of that buffer. From that moment on, this bit remains set.

3.3.2.6 CYCLCNT[5:0] — Cycle Counter

The cycle counter field holds the CC cycle counter value at frame reception time. This field is not used in message buffers configured for transmission.

3.3.2.7 LEN[6: 0] — Payload Length

The payload length field holds the number of words (1 word = 2 bytes) contained in the payload segment of the frame.

Receive message buffers and receive FIFO:

The payload field indicates the value of the payload length field in the received frame (see [Section 3.3.3, “Message Buffer Slot Status Vector”](#)).

Transmit message buffers:

The payload field indicates the number of words to be transmitted.

If the host writes a payload length not equal to SPLR into a static frame, the CC generates the CHI error interrupt SPLME (see [Section 3.2.3.6.3, “CHI Error Register \(CHIER\)”](#)).

If the host writes a payload length greater than MPLDR into a dynamic frame, the CC generates the CHI error interrupt MDPLE (see [Section 3.2.3.6.3, “CHI Error Register \(CHIER\)”](#)).

Note that the size of the data field in the MFR4200 is limited to 32 bytes (see [Section 3.1.1, “MFR4200 Features”](#)).

3.3.2.8 HCRC[10:0] — Header CRC

The header CRC field contains a cyclic redundancy check code (CRC) computed over the sync bit, startup bit, the frame ID, and the payload length fields of the frame.

Receive message buffers and Receive FIFO:

The header CRC field contains the header CRC of the semantically valid and syntactically correct received frame.

Transmit message buffers:

The Header CRC field contains the Header CRC value calculated and provided by the host. Note that the controller does not check if the Header CRC provided by the host is correct.

3.3.2.9 SYNC — Sync Bit

The SYNC bit determines whether the frame is to be used for clock synchronization.

Receive message buffers and Receive FIFO:

The bit contains the SYNC bit of the stored frame. This bit is updated only when a new semantically valid frame matching the buffer filters has been stored in the message buffer.

Transmit message buffers:

This bit is not used.

NOTE

The host sets up the slot ID determining the slot during which the CC transmits a sync frame via the sync frame register SYNCFR (see [Section 3.2.3.3.29, “Sync Frame Register \(SYNCFR\)”](#)).

3.3.2.10 STARTUP — Startup Bit

The STARTUP bit determines whether the frame is to be used for clock synchronization during startup.

Receive message buffers and Receive FIFO

The bit contains the STARTUP bit of the stored frame. This bit is updated only when a new semantically valid frame matching the buffer filters has been stored in the message buffer.

Transmit message buffers

This bit is not used.

NOTE

The host sets up the STARTUP bit for transmit frames via the startup bit SUP in register SYNCFR (see [Section 3.2.3.3.29, “Sync Frame Register \(SYNCFR\)”](#)).

3.3.3 Message Buffer Slot Status Vector

All message buffers, including transmit buffers, comprise a message buffer slot status vector holding a 9-bit wide slot status information field.

15	14	13	12	11	10	9	8
Reserved	Reserved	Reserved	Reserved	Reserved	Reserved	Reserved	CH
r	r	r	r	r	r	r	r
7	6	5	4	3	2	1	0
VCE	SYNCF	NULLF	SUPF	SERR	CERR	BVIOL	TXCON
r	r	r	r	r	r	r	rh*

Figure 3-119. Transmit Message Buffer Slot Status Vector

15	14	13	12	11	10	9	8
Reserved	Reserved	Reserved	Reserved	Reserved	Reserved	Reserved	CH
r	r	r	r	r	r	r	rh*
7	6	5	4	3	2	1	0
VCE	SYNCF	NULLF	SUPF	SERR	CERR	BVIOL	TXCON
rh*	rh*	rh*	rh*	rh*	rh*	rh*	r

Figure 3-120. Receive and Receive FIFO Message Buffer Slot Status Vector

NOTE

- The CC indicates status information for transmit message buffers only, in the TXCON bit; the remaining bits are used to indicated receive status information. Therefore, if a message buffer is configured as a receive or receive FIFO message buffer, its TXCON bit is not used by the CC. If a message buffer is configured as a transmit message buffer, only its TXCON bit is updated by the CC, while the remaining bits are not used by the controller.
- Refer to [Table 3-4](#) for slot status monitoring availability in different protocol states.
- After reception of a null frame or an invalid frame, the controller updates only the slot status vector of a selected receive message buffer or FIFO buffer. Other fields (see [Table 3-11](#) and [Table 3-12](#)) of those buffers stay unaltered.
- After reception of a valid frame, the controller updates the slot status vector and the remainder of the receive message buffer or FIFO buffer.
- After transmission of a frame, the controller updates the slot status vector in the current transmit message buffer.
- The controller updates a message buffer assigned to slot n within the first macrotick of the slot n+1.
- Empty static slots exhibit slot status 0x0000 on channel A and 0x0100 on channel B.

3.3.3.1 TXCON — TX Conflict

This flag indicates transmission conflicts, i.e. indicates that a reception is in progress when the controller starts transmission. This bit indicates conflicts during transmission in static and dynamic segments.

0 – No transmission conflict detected.

1 – Transmission conflict detected.

3.3.3.2 BVIOL — Boundary Violation

This flag provides information about media activity at slot boundaries (either the end or the beginning of the current slot). Note that this is not necessarily an error condition, as a semantically valid frame can be received between the slot boundaries, provided that the idle conditions before and after the frame are fulfilled.

0 – No media activity detected at slot boundaries.

1 – Media activity detected at slot boundaries.

3.3.3.3 CERR — Content Error

This flag indicates the reception of a semantically incorrect frame.

0 – No content error occurred in current slot.

1 – Content error occurred in current slot.

3.3.3.4 SERR — Syntax Error

This flag indicates the reception of a syntactically incorrect frame.

0 – No syntax error occurred in current slot.

1 – Syntax error occurred in current slot.

3.3.3.5 SUPF — Startup Frame Indication

This flag indicates the reception of a frame header having its startup bit set.

0 – No syntactically correct startup frame received in current slot.

1 – Syntactically correct startup frame received in current slot.

3.3.3.6 NULLF — NULL Frame Indication

This flag indicates the reception of a frame header having its null frame indication bit set.

0 – No syntactically correct null frame received in current slot.

1 – Syntactically correct null frame received in current slot.

3.3.3.7 SYNCF — SYNC Frame Indication

This flag indicates the reception of a frame header having its sync frame indication set.

0 – No syntactically correct sync frame received in current slot.

1 – Syntactically correct sync frame received in current slot.

3.3.3.8 VCE — Valid Communication Element

This flag indicates the reception of a valid communication element. A valid communication element is either a syntactically and semantically correct frame or symbol.

0 – No valid communication element received in current slot.

1 – Valid frame received in current slot.

3.3.3.9 CH — Channel

This flag indicates the channel the slot status refers to.

0 – Slot status of channel A.

1 – Slot status of channel B.

3.3.4 Message ID

If the payload preamble bit PP is set, the message ID field holds the message ID of a dynamic frame located in the message buffer. The FIFO filter may use the received message ID for message ID filtering.

3.3.5 NMVector Fields

If the payload preamble bit PP is set, the network management vector fields hold the network management vector of a static frame located in the message buffer.

3.3.6 Data[0:31] — Data Fields

Receive message buffers:

The data fields store received frame payload data, if all the receive filtering criteria are met.

Transmit message buffers:

The host writes these data fields with payload data to be transmitted.

Receive FIFO:

The data fields in the FIFO buffer stores a received frame's payload data values if the channel, message ID, and cycle counter are accepted by the configured receive FIFO acceptance filter value and mask, and not rejected by the configured receive FIFO rejection filter value and mask, and if there is no matching dedicated receive message buffer in the mailbox.

3.4 Message Buffer Control, Configuration, Status and Filtering Register Set

3.4.1 Message Buffer Control, Configuration and Status Register

Message buffer control, configuration and status register (BUFCSnR[0:58]). The BUFCS[0:58] layout is the same for receive message buffers, transmit message buffers and FIFO. However, the access rules for register bits depend on various modes of operation and on the buffer configuration.

Bit	15	14	13	12	11	10	9	8
Name	VALID RO_NO/WR_CS	TT NU	CCFE RO_NO/WR_CS	BT NU	DATUPD RO_NO/WR_CS	ChB RO_NO/WR_CS	ChA RO_NO/WR_CS	BUFCSMT NU
Hard Reset	0							
Access	rwh*	r	rw*	r	rwh*	rw*	rw*	r

Bit	7	6	5	4	3	2	1	0
Name	Reserved NU	LOCK WR	Reserved NU	Reserved NU	IENA WR	IFLG RO	Reserved NU	CFG RO_NO/WR_CS
Hard Reset					0	0		0
Access	r	rw	r	r	rw	rh	r	rw*

Figure 3-121. BUFCSnR of a Receive Message Buffer

Bit	15	14	13	12	11	10	9	8
Name	VALID RO	TT WR	CCFE RO_NO/WR_CS	BT RO_NO/WR_CS	DATUPD NU	ChB RO_NO/WR_CS	ChA RO_NO/WR_CS	BUFCSMT WR
Hard Reset	0							
Access	rh	rw	rw*	rw*	r	rw*	rw*	rw

Bit	7	6	5	4	3	2	1	0
Name	Reserved NU	LOCK WR	Reserved NU	Reserved NU	IENA WR	IFLG RO	Reserved NU	CFG RO_NO/WR_CS
Hard Reset					0	0		0
Access	r	rw	r	r	rw	rh	r	rw*

Figure 3-122. BUFCSnR of a Transmit Message Single Buffer for the Dynamic Segment

Message Buffer Control, Configuration, Status and Filtering Register Set

Bit	15	14	13	12	11	10	9	8
Name	VALID RO	TT RO_NO/WR_CS	CCFE RO_NO/WR_CS	BT RO_NO/WR_CS	DATUPD NU	ChB RO_NO/WR_CS	ChA RO_NO/WR_CS	BUFCMT WR
Hard Reset	0							
Access	rh	rw*	rw*	rw*	r	rw*	rw*	rw

Bit	7	6	5	4	3	2	1	0
Name	Reserved NU	LOCK WR	Reserved NU	Reserved NU	IENA WR	IFLG RO	Reserved NU	CFG RO_NO/WR_CS
Hard Reset					0	0		0
Access	r	rw	r	r	rw	rh	r	rw*

Figure 3-123. BUFCSnR of a Host Part Transmit Message Buffer of a Double Tx Buffer for the Dynamic Segment

Bit	15	14	13	12	11	10	9	8
Name	VALID RO	TT RO_NO/WR_CS	CCFE RO_NO/WR_CS	BT RO_NO/WR_CS	DATUPD NU	ChB RO_NO/WR_CS	ChA RO_NO/WR_CS	BUFCMT WR
Hard Reset	0							
Access	rh	rw*	rw*	rw*	r	rw*	rw*	rw

Bit	7	6	5	4	3	2	1	0
Name	Reserved NU	LOCK WR	Reserved NU	Reserved NU	IENA WR	IFLG RO	Reserved NU	CFG RO_NO/WR_CS
Hard Reset					0	0		0
Access	r	rw	r	r	rw	rh	r	rw*

Figure 3-124. BUFCSnR of a Host Part Transmit Message Buffer of a Double Tx Buffer for the Static Segment

Bit	15	14	13	12	11	10	9	8
Name	VALID RO	TT RO_NO/WR_CS	CCFE RO_NO/WR_CS	BT RO_NO/WR_CS	DATUPD NU	ChB RO_NO/WR_CS	ChA RO_NO/WR_CS	BUFCMT WR
Hard Reset	0							
Access	rh	rw*	rw*	rw*	r	rw*	rw*	rw

Bit	7	6	5	4	3	2	1	0
Name	Reserved NU	LOCK WR	Reserved NU	Reserved NU	IENA WR	IFLG RO	Reserved NU	CFG RO_NO/WR_CS
Hard Reset					0	0		0
Access	r	rw	r	r	rw	rh	r	rw*

Figure 3-125. BUFCSnR of a Single Transmit Message Buffer for the Static Segment

Bit	15	14	13	12	11	10	9	8
Name	VALID RO	TT RO	CCFE RO	BT RO	DATUPD NU	ChB RO	ChA RO	BUFCMT RO
Hard Reset	0							
Access	rh	r	r	r	r	r	r	r

Bit	7	6	5	4	3	2	1	0
Name	Reserved NU	LOCK NU	Reserved NU	Reserved NU	IENA RO	IFLG RO	Reserved NU	CFG RO
Hard Reset					0	0		0
Access	r	r	r	r	r	rh	r	r

Figure 3-126. BUFCSnR of a CC Part Transmit Message Buffer of a Double Tx Buffer for Dynamic and Static Segment

Bit	15	14	13	12	11	10	9	8
Name	VALID NU	TT NU	CCFE NU	BT NU	DATUPD NU	ChB NU	ChA NU	BUFCMT NU
Hard Reset	0							
Access	r	r	r	r	r	r	r	r

Bit	7	6	5	4	3	2	1	0
Name	Reserved NU	LOCK WR	Reserved NU	Reserved NU	IENA NU	IFLG NU	Reserved NU	CFG NU
Hard Reset					0	0		0
Access	r	rwh	r	r	r	r	r	r

Figure 3-127. BUFCSnR of FIFO Buffer

Where:

RO_NO/WR_CS	Host read/write access during the configuration state, in other states – Host read access;
RO	Host read-only access
WR	Host read/write access
NU	Reserved or not used

3.4.1.1 CFG — Message Buffer Configuration Bit

This bit is used to configure the corresponding buffer as a transmit or receive message buffer. CFG bit is cleared by a hard reset. The access to this bit is defined in [Table 3-16](#).

- 1 – The corresponding buffer is configured as a transmit message buffer.
- 0 – The corresponding buffer is configured as a receive message buffer.

3.4.1.2 IFLG — Interrupt Status Flag

The IFLG flag is provided by the CC. It performs different functions depending on the configuration of the corresponding message buffer.

Receive message buffer:

The flag indicates that the controller has updated the receive message buffer due to frame reception (update of data fields and the slot status vector after reception of a valid frame, or update of the slot status vector after reception of an invalid frame). The host can clear the flag by a buffer lock operation.

1 – The controller sets the flag when the receive message buffer was updated after a frame reception. The host must process received data and clear the IFLG bit.

0 – The message buffer is not updated, or the host has cleared the IFLG bit implicitly by locking the message buffer.

Transmit message buffer:

The flag indicates that the message buffer is empty, or that the controller has transmitted a frame from that message buffer. The host can clear the flag by a buffer lock operation.

1 – The flag is set by the controller when the transmit message buffer is empty/not updated (i.e. has been transmitted). The host may write new data to the buffer.

0 – The flag is cleared implicitly by the host when the transmit message buffer is updated (i.e. locked).

Receive FIFO buffer:

The flag has no meaning; it will never be set.

NOTE

1. The IFLG bit is set to the value of the CFG bit with each write to a BUFCSnR register, during the configuration state. During normal operation, the controller updates the IFLG bit after frame transmission (transmit message buffer) and after frame reception (receive message buffer).
 - If CFG is clear (receive message buffer) the CC clears the IFLG bit, also, indicating that the receive message buffer does not hold new receive data.
 - If CFG is set (transmit message buffer) the CC sets the IFLG bit, also, indicating that the transmit message buffer is empty and will be filled by the host application.
2. If the host does not write to a BUFCSnR register during the configuration state, the IFLG holds the value it had before it entered the configuration state.

3.4.1.3 IENA — IFLG Interrupt Enable

This bit enables the corresponding message buffer as an IFLG bit interrupt source. If the message buffer is configured as a receive message buffer, the generated by the CC interrupt is a read interrupt. If the message buffer is configured as a transmit message buffer, the interrupt generated by the CC is a write interrupt.

1 – The corresponding message buffer interrupt is enabled.

0 – The corresponding message buffer interrupt is disabled.

This bit is not used for the FIFO.

3.4.1.4 LOCK — Message Buffer Lock Request

The bit has various functions depending on the configuration of the corresponding message buffer.

The host can implicitly lock/unlock the buffer by writing ‘1’ to the LOCK bit. Writing a ‘1’ to the LOCK bit toggles the value of the LOCK bit:

- A buffer is locked when the LOCK bit read operation returns ‘1’.
- A buffer is unlocked when the LOCK bit read operation returns ‘0’.

Receive FIFO:

The host must lock a FIFO buffer to make it accessible in the active receive FIFO buffer window. The host can request a FIFO buffer lock by writing a ‘1’ to the LOCK bit of buffer 0, provided the FIFO is configured. Writing a ‘0’ to the LOCK bit has no effect on the bit. An attempt to lock the FIFO through, not buffer 0, but another FIFO buffer’s LOCK bit, causes a FIFO buffer lock error (see [Section 3.2.3.6.3, “CHI Error Register \(CHIER\)”](#)).

Receive message buffer:

The host must lock a receive message buffer in order to make it accessible in the active receive message buffer window. The host can request a message buffer lock by writing a ‘1’ to the LOCK bit. Writing a ‘0’ to the LOCK bit has no effect on the bit. When the buffer is locked, the LOCK bit read operation returns ‘1’.

Transmit message buffer:

The host must lock the buffer in order to make it accessible through the active transmit message buffer window. The host can request a buffer lock by writing a ‘1’ to the LOCK bit. Writing a ‘0’ to the LOCK bit has no effect on this bit. When the buffer is locked, the LOCK bit read operation returns ‘1’. A buffer committed for transmission (appropriate BUFCMT bit is ‘1’) cannot be locked. If the host sends a lock request for the committed transmit message buffer, a lock error will be raised (see [Section 3.2.3.6.3, “CHI Error Register \(CHIER\)”](#)).

NOTE

- For more information about the locking/unlocking procedure, see [Section 3.5.3.4, “Active Buffers Locking/Unlocking and Locking Timing”](#).
- Writing to the LOCK bit causes all other bits of a message buffer control and status register to be ignored for this write access to the buffer control register, i.e. it is not possible to update the buffer control register with the same write operation as toggles the locked/unlocked status of the buffer. The lock/unlock request is not stored — there is no pending lock request.

- Unlocking the buffer in the FIFO moves the FIFO buffer access pointer to the next buffer in the FIFO (see [Section 3.6, “Receive FIFO Function”](#)). So, the FIFO does not support multiple consecutive locking/unlocking of the same FIFO entry.
- The host locks the FIFO buffers by setting the LOCK bit in FIFO buffer number 0.

3.4.1.5 BUFCMT — Message Buffer Commit Flag

The host commits a transmit message buffer for transmission by setting the BUFCMT flag of the corresponding buffer to ‘1’.

The CC checks the BUFCMT bit of all transmit message buffers when it schedules a transmission.

The CC can transmit, or put a frame from a transmit message buffer into a transmission schedule, only when the buffer is committed for transmission (BUFCMT = 1), unlocked (LOCK = 0), and all internal procedures on that transmit message buffer are finished (copying process, unlock process, a transmission).

At the end of buffer transmission, The CC clears the BUFCMT bits of single transmit message buffers and CC part buffers of double transmit message buffers committed for transmission.

The CC clears the BUFCMT bit of a double buffer’s host part at the end of the buffer copy process. During the buffer copy process, the CC copies buffer data from the buffer’s CC part to the buffer’s host part.

The host may set the BUFCMT bit only for a locked transmit message buffer. To complete the commit operation, the host must unlock the buffer. Thereafter, the CC indicates a successful commitment with the BUFCMT set. The read operation of a BUFCMT bit always returns a ‘0’ for a locked buffer.

1 – The transmit message buffer is committed for transmission.

0 – The transmit message buffer is not committed for transmission.

NOTE

This flag is related only to transmit message buffers. Reading or writing to BUFCMT bit in a receive message buffer has no meaning (i.e., this bit is not used). When the host writes ‘1’ to the BUFCMT bit, that value will be stored until the CC clears it; so, only one write is necessary. Writing a ‘0’ to the BUFCMT location does not change its state.

3.4.1.6 ChA, ChB — Channel A and Channel B Flags

ChA and ChB are channel filtering bits associated with each buffer. They serve as a filter for a receive message buffer, and as a control field for a transmit message buffer.

Receive message buffer:

Received frames are stored if they are received on all the specified channels in the channel filtering field. Other filtering criteria must also be met.

Transmit message buffer:

The content of the buffer is transmitted only on the channels specified in the channel filtering field when the cycle counter filtering and frame ID filtering criteria are also met.

Receive FIFO:

Those bits have no meaning for the receive FIFO (refer to [Section 3.6, “Receive FIFO Function”](#) for more information about FIFO filters)

Table 3-15. Channel Filtering Configuration

ChA	ChB	Transmit message buffer Transmit frame	Receive message buffer Store semantically valid received frame
1	1	on both channels	ignore frame
1	0	on channel A	received on channel A
0	1	on channel B	received on channel B
0	0	no transmission	ignore frame

3.4.1.7 CCFE — Cycle Counter Filtering Enable Bit

The host controls the cycle counter filtering (refer to [Section 3.2.3.8.4, “Cycle Counter Filter n Register, n = \[0:58\] \(CCFnR\)”](#)) of a buffer by the cycle counter filtering enable bit.

- 1 – Cycle counter filtering is enabled.
- 0 – Cycle counter filtering is not performed.

3.4.1.8 DATUPD — Data Updated

DATUPD indicates if the frame data was or was not updated during the last matching slot/cycle/channel triple in the static segment according to the filter. The CC updates the DATUPD bit after every static slot assigned to this buffer. The host may reset this bit during the configuration state by writing a “0” to the bit.

Note that DATUPD is not reset by empty minislots in the dynamic segment. It is set, however, when a semantically valid frame is received in the dynamic segment.

- 1 – A semantically valid (non null) frame was received during the last slot with a matching slot/cycle/channel triple.
- 0 – Either a frame that was not semantically valid or a null frame was received during the last slot with a matching slot/cycle/channel triple.

3.4.1.9 BT — Buffer Type

The host can configure every buffer of the CC as a single transmit message buffer or as a double message buffer. The handling and the operations for buffers with different types are specified in [Section 3.5, “Message Buffer Handling and Operations”](#).

- 0 – Single transmit message buffer.

1 – Double transmit message buffer.

3.4.1.10 TT — Type of Transmission

The host can configure the type of transmission used for a buffer. Therefore, the CC can combine two types of systems — event and state driven systems.

0 – Event type of transmission

1 – State type of transmission

NOTE

The TT bit controls how the CC operates with the VALID bit.

3.4.1.11 VALID — Message Buffer Valid Flag

The semantic of this status bit depends on the configuration of the message buffer.

Transmit message buffer:

The valid bit indicates whether a transmit buffer holds valid for transmission data or not.

The CC clears the VALID bit of a transmit message buffer when the host locks it.

When the host has committed the buffer for transmission (see the BUFCMT bit description in [Section 3.4.1, “Message Buffer Control, Configuration and Status Register”](#)) and unlocked it, the controller performs the following operations:

- Sets the appropriate VALID bit — valid data frame.
- Clears the VALID bit when the frame has been transmitted, if the appropriate TT bit of the buffer is clear (event type of transmission).
- Does not change the VALID bit when the frame has been transmitted, if the appropriate TT bit of the buffer is set (state type of transmission).

1 – The corresponding buffer contains a semantically valid frame to be transmitted.

0 – The corresponding buffer does not contain a semantically valid frame to be transmitted.

Receive message buffer

The VALID bit indicates whether a receive message buffer holds semantically valid frame data or not.

It is up to the host to reset this bit during the configuration state. It changes to ‘1’ when the first valid non null frame is received.

1 – The corresponding buffer contains semantically valid frame data.

0 – The corresponding buffer does not contain semantically valid frame data.

NOTE

The host can write the VALID bit only during the configuration state, for receive message buffers. During all other modes of the CC this bit is read-only.

3.4.1.12 Reserved — Reserved

Those bits are reserved for future use. Reserved bit are accessible by host read operations only. They have an undefined state.

3.4.2 Message Buffer Filter Registers

The cycle counter filter register CCFnR[0:58] is shown in the following figures.

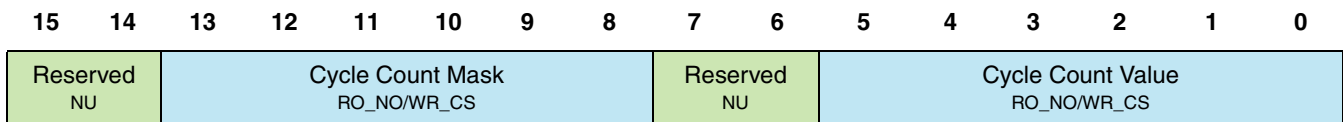

Figure 3-128. CCFnR, Transmit and Receive Message Buffer Filter Registers



Figure 3-129. CCFnR, CC Part Buffer of a Double Transmit Message Buffer Filter Registers



Figure 3-130. CCFnR, FIFO Buffer Filter Registers

Where:

RO_NO/WR_CS	Field with host read-only access during normal operation (host write access in configuration state only)
RO	Field with host read-only access
NU	Reserved or not used

Message buffer filter registers sets are used only for transmit and receive message buffers, not for the FIFO. The FIFO has its own filter register set (see [Section 3.2.3.8, “Filtering Related Registers”](#)).

3.4.2.1 Cycle Counter Filter Register (CCFnR)

The operation of the filtering mechanism depends on the configuration of the buffer.

Receive message buffer:

The received frame is stored only if all the following conditions are met.

- The received cycle counter matches an element of the buffer's cycle filter register, if cycle filtering is enabled;
- Channel and frame ID criteria are met;
- The received message has passed all error checks (see the PWD: Message Error Check chapter)

Transmit message buffer:

The content of the buffer is transmitted, when an element of the cycle filter register matches the current cycle counter, and the frame ID matches the slot counter value.

For a detailed description of the CCFR registers, see [Section 3.2.3.8.4, “Cycle Counter Filter n Register, n = \[0:58\] \(CCFnR\)”](#).

3.4.3 Receive FIFO Filters

There are two filter sets available for FIFO filtering:

- One FIFO acceptance filter set, comprising the following registers:
 - FIFO acceptance filter message ID value register (see [Section 3.2.3.8.5, “FIFO Acceptance Filter Message ID Value Register \(FAFMIDVR\)”](#))
 - FIFO acceptance filter message ID mask register (see [Section 3.2.3.8.6, “FIFO Acceptance Filter Message ID Mask Register \(FAFMIDMR\)”](#))
- One FIFO rejection filter set, comprising the following registers:
 - FIFO rejection filter frame ID value register (see [Section 3.2.3.8.8, “FIFO Rejection Filter Frame ID Value Register \(FRFFIDVR\)”](#))
 - FIFO rejection filter frame ID mask register (see [Section 3.2.3.8.9, “FIFO Rejection Filter Frame ID Mask Register \(FRFFIDMR\)”](#))

The channels, from which the received frame will be accepted or rejected by the FIFO acceptance/rejection filters, are specified by the FAFCHR register (see [Section 3.2.3.8.7, “FIFO Acceptance/Rejection Filter Channel Register \(FAFCHR\)”](#)).

NOTE

The information from a received frame will be stored in the FIFO provided the following conditions are met:

- The receive message buffer filtering did not succeed, i.e. none of the configured receive message buffers has a matching filter.
- The message ID is accepted by the configured acceptance filter set.
- The frame ID is not rejected by the configured rejection filter set.

NOTE

Frame ID filtering and message ID filtering can be enabled/disabled independently of each other by setting the masks and values appropriately:

- To disable frame ID filtering, set the frame ID value to 0x0000 and the frame ID mask to 0xFFFF. (No semantically valid frame ID will be rejected.)
- To disable message ID filtering, set the message ID mask to 0x0000 (all message IDs are accepted).

3.5 Message Buffer Handling and Operations

3.5.1 Introduction

The FlexRay MFR4200 uses a partial double buffering technique to provide a scheme for buffer handling. Using this technology, buffers can be configured as single/double transmit message buffers, or partially, as single and as double transmit message buffers, as required by the application. At the same time, the FlexRay MFR4200 offers enhanced:

- Active window mechanism
- Interrupt service
- Buffer access scheme

The new buffer handling and operations scheme has the following features.

- The host and the CC have independent access to all the buffers. Therefore, the host can access receive/transmit message buffers almost instantly while the CC transmits/receives frames.
- The host can configure receive/transmit buffers in the configuration state and partially, during normal operation (see [Section 3.5.5, “Buffer Reconfiguration in the Normal State of Operation”](#)).
- The buffer configuration map is flexible.
- The buffer mechanism supports multiple locking/unlocking of the same transmit buffer, without committing for transmission.
- The host can commit a transmit message buffer for transmission without update or with only partial update of its data fields.
- The host explicitly controls every transmit buffer commitment for transmission.
- The host can access a receive message buffer while the CC receives a new frame for that buffer.

All features are described in more detail in the following sections.

3.5.2 Buffer Map

The FlexRay CC memory map including buffers locations is shown in [Table 3-1](#).

The host accesses CC internal buffer data, configuration, and status fields only through appropriate active receive/transmit/FIFO message buffers by using the locking mechanism. Shadow receive message buffers serve the host accesses to message buffers while the CC continues to receive/transmit frames.

3.5.3 Active Message Buffers

The concept of active message buffers simplifies buffer access for the host. If a buffer is locked by the host, then, depending on the message buffer configuration, the buffer data and configuration information is mirrored to one of the active buffers — the active receive message buffer, the active transmit message buffer, or the active receive FIFO buffer.

3.5.3.1 Active Receive Message Buffer

The active receive message buffer (see [Table 3-1](#)) contains receive message buffer data and configuration fields. Any receive message buffer is accessible through the active receive message buffer after the locking procedure for this buffer has been finished. The active receive message buffer layout is shown in [Table 3-11](#).

Buffer control, configuration, filtering and status data is stored in the buffer control, configuration, status and filtering registers set. The layout of the set is presented in [Figure 3-131](#).

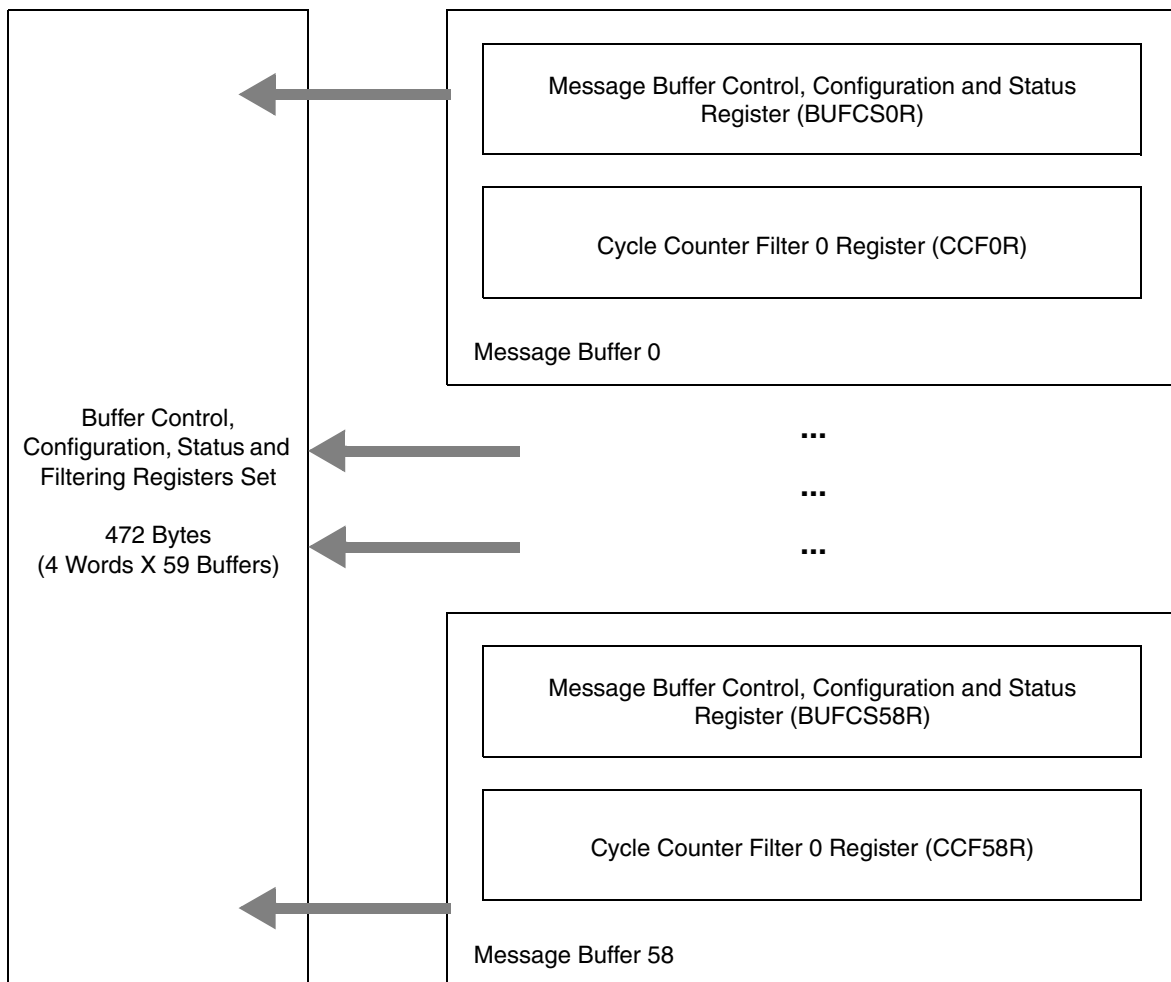

Figure 3-131. Buffer Control, Configuration, Status/Filtering Register Set for Transmit/Receive Buffers

NOTE

[Figure 3-131](#) does not apply to message buffers configured as receive FIFO buffers.

3.5.3.2 Active Transmit Message Buffer

The active transmit message buffer (see [Table 3-1](#)) contains transmit message buffer data and configuration fields. Any transmit message buffer is accessible through the active transmit message buffer after the buffer has been locked successfully. The active transmit message buffer layout is shown in [Table 3-13](#).

Buffer control, configuration, filtering and status data is stored in the buffer control, configuration, status and filtering registers set. The layout of the set is presented in [Figure 3-131](#).

3.5.3.3 Active Receive FIFO Buffer

The active receive FIFO message buffer (see [Table 3-1](#)) contains receive FIFO buffer data and configuration fields. Any receive FIFO buffer is accessible through the active receive FIFO buffer after the locking procedure for this buffer has been finished.

For a detailed description of FIFO access, refer to [Section 3.6, “Receive FIFO Function”](#). The active receive FIFO buffer layout is shown in [Table 3-12](#). The locking procedure for receive FIFO buffers is different from the receive/transmit message buffer locking operation (see [Section 3.5.3.4, “Active Buffers Locking/Unlocking and Locking Timing”](#) and the LOCK bit description in [Section 3.2.3.7.2, “Message Buffer Control, Configuration and Status n Register, n = \[0:58\] \(BUFCSnR\)”](#)).

NOTE

[Figure 3-131](#) is applicable for transmit and receive message buffers only, not for receive FIFO buffers.

If a buffer is configured as a receive FIFO buffer, only its buffer control, configuration and status register (BUFCSnR) is used; the CCFnR registers are not. Instead of the CCFnR registers, the FIFO acceptance filter registers and FIFO rejection filter registers must be used.

The buffer control, configuration, status and filtering register set for the receive FIFO buffers is shown on the [Figure 3-132](#). Buffer 0 is configured as a receive FIFO buffer.

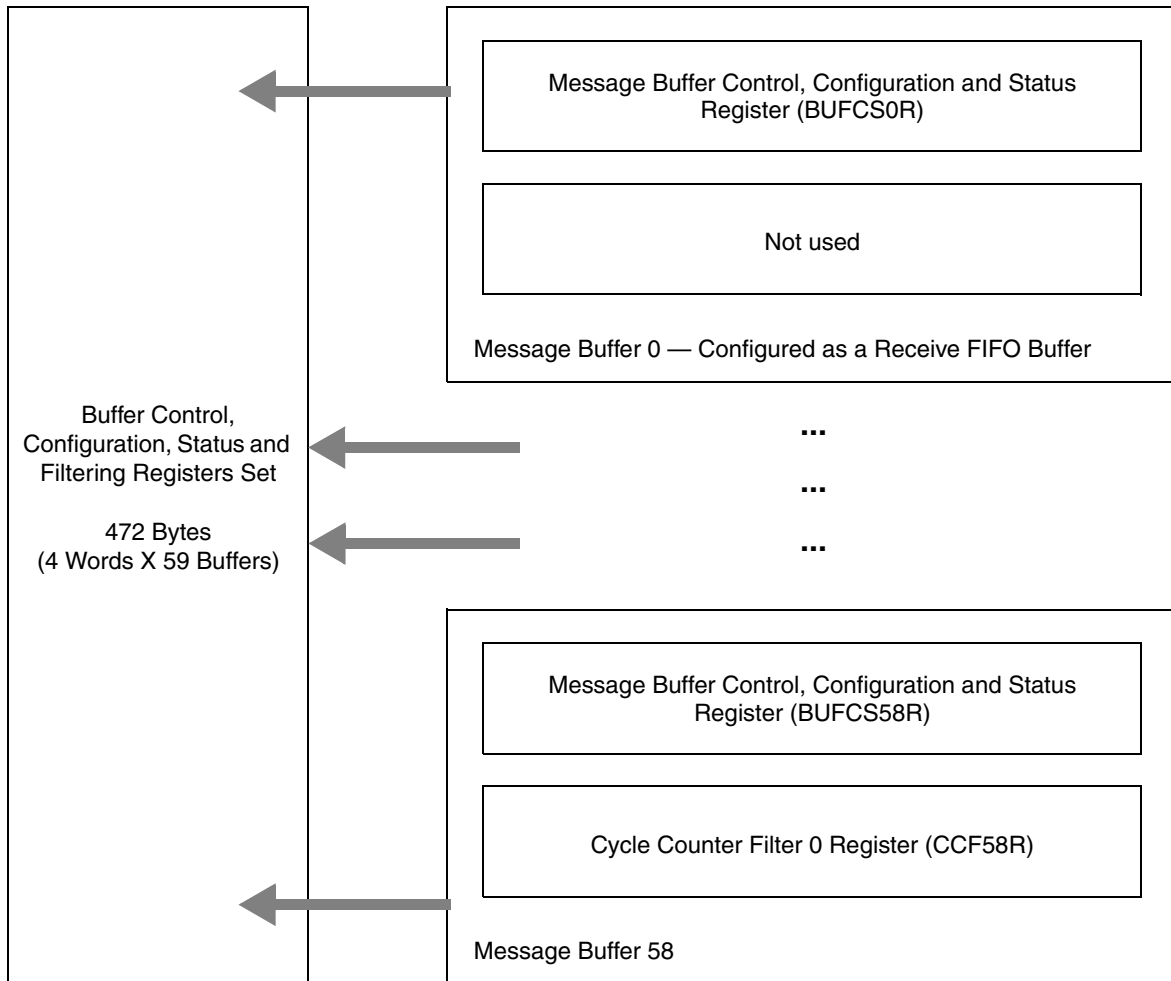

Figure 3-132. Buffer Control, Configuration, Status/Filtering Register Set for Receive FIFO Buffers

Buffer 0 is configured as a receive FIFO buffer; the remaining buffers are configured as receive or transmit message buffers.

3.5.3.4 Active Buffers Locking/Unlocking and Locking Timing

The host accesses any buffer through the active buffers by using the locking/unlocking mechanism.

The LOCK bit serves as locking request (control data) and acknowledgement (status data) at the same time (hence, the host write and read operations to that bit return different values). For a detailed description of the LOCK bit, refer to [Section 3.4, “Message Buffer Control, Configuration, Status and Filtering Register Set”](#).

Locking/unlocking procedure:

1. The host sends a message buffer lock request by writing ‘1’ to the appropriate LOCK bit of the message buffer in the BUFCSnR register (see [Section 3.4.1, “Message Buffer Control, Configuration and Status Register”](#)).

2. The host checks that the message buffer is locked (accessible through an active buffer) by reading the LOCK bit. If the resulting value is '1', the message buffer was locked successfully. Otherwise, the message buffer could not be locked and the lock request must be repeated.
3. At the same time, the host checks for a locking error by reading the lock interrupt flag CHIERRIF in the interrupt status register ISR0 (see [Section 3.2.3.6.6, "Interrupt Status Register 0 \(ISR0\)"](#)).
4. In the event of a locking error, the host may determine the cause of the error (see [Section 3.2.3.6.3, "CHI Error Register \(CHIER\)"](#)), and may retry, if necessary.
5. Depending on the message buffer type, the host performs buffer read or read/write operations when the message buffer becomes available through an active buffer (LOCK = '1'). All transmit message buffers are accessible through the active transmit message buffer, receive message buffers through the active receive message buffer, and FIFO buffers through the active receive FIFO buffer. Once the message buffer is locked, the host accesses it without checking the LOCK bit.
6. When the host has finished the message buffer update, it can unlock the message buffer by writing again '1' to the LOCK bit. This request to unlock the message buffer is always and immediately granted, so the host does not have to check the state of the LOCK bit.
7. The host can start a locking procedure for another message buffer.

Locking principles:

- The host accesses the FIFO, receive message buffers, and transmit message buffers only through the active receive FIFO buffer, the active receive message buffer, and the active transmit message buffer.
- The host must lock a buffer, to make it accessible through an active message buffer.
- The host must unlock a message buffer when it has finished accessing it.
- The host cannot access shadow message buffers.
- The host cannot lock more than one receive message buffer and not more than one transmit message buffer.
- The host can lock up to three buffers mirrored to the appropriate active buffers at the same time — one transmit message buffer, one receive message buffer, and one receive FIFO buffer.
- The host may lock and unlock transmit and receive message buffers several times before committing them.
- The host may commit a transmit message buffer for transmission (by setting BUFCMT to '1') after performing several locking/unlocking procedures on that buffer before committing.
- Unlocking the buffer in the FIFO will move the FIFO buffer access pointer to the next buffer in the FIFO. Therefore, the FIFO does not support multiple consecutive locking/unlocking procedures for one FIFO buffer.
- The host cannot lock CC part buffers of double transmit message buffers.
- The host can lock only the host part buffers of double transmit message buffers.
- Once the buffer is locked, the host accesses it without checking the LOCK bit.

Locking errors:

Refer to [Section 3.2.3.6.3, “CHI Error Register \(CHIER\)”](#) for a detailed description. The most important points are as follows.

- If the controller receives two frames for a receive message buffer that is locked by the host, the controller discards the older frame and sets the frame lost error FLE in the CHIER register.
- A message buffer committed for transmission (its BUFCMT bit is ‘1’) cannot be locked. If the host sends a lock request for the committed transmit message buffer, a lock error is raised.
- The host cannot access the odd buffers (CC part buffers) of the double transmit message buffers. If it sends a locking request for any odd buffer of a double transmit message buffer, a lock error is raised.
- If the host tries to lock a second transmit or receive buffer or a second FIFO buffer, the controller issues a lock error. See the description of the RBLE, TBLE, FBLE bits in [Section 3.2.3.6.3, “CHI Error Register \(CHIER\)”](#).

NOTE

The host can write the BUFCMT bit of a message buffer only after the buffer is locked and available through an active buffer. The BUFCMT bit is part of the message buffer control, configuration, and status registers BUFCSnR[0:58] (see [Section 3.4.1, “Message Buffer Control, Configuration and Status Register”](#)).

Locking timing:

If a transmit message buffer (single or double) was committed for transmission in slot n and unlocked by the host, and if the CC has scheduled this buffer for transmission in slot n, then this buffer is locked by the CC for transmission (see the BB bit description in [Section 3.2.3.6.3, “CHI Error Register \(CHIER\)”](#)) for the time shown in [Figure 3-133](#).

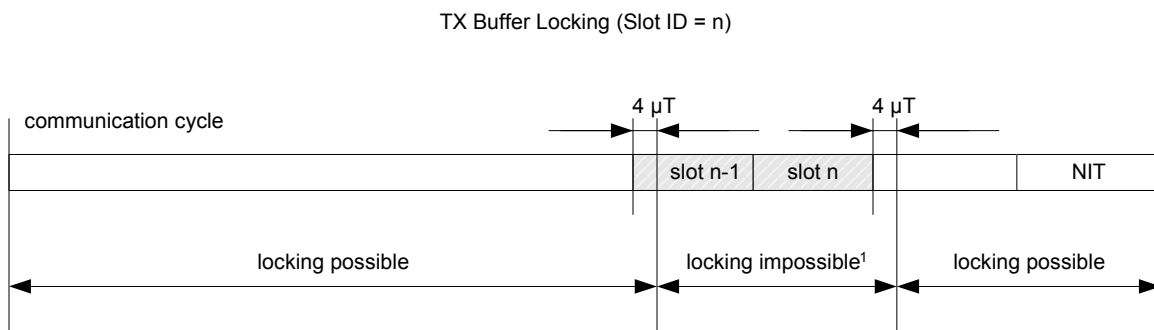

¹ If the host issues a lock request here, the CC does not grant the lock request, but sets the BB flag in the CHIER register indicating a transmit message buffer busy lock error.

Figure 3-133. Buffer Busy Bit Timing for a Transmit Message Buffer

3.5.4 Buffer Configuration

For the CC to start up correctly, the host must configure all the used buffers during the configuration state. The host can reconfigure buffers partially during normal operation (see [Section 3.5.5, “Buffer Reconfiguration in the Normal State of Operation”](#)). An example of buffer configuration is presented in [Figure 3-134](#).

Each buffer is one of following:

- Receive FIFO buffer
- Receive message buffer
- Single transmit message buffer
- Double transmit message buffer

Each double transmit message buffer consists of two parts — the host part buffer and the CC part buffer.

The host part buffer of a double transmit message buffer is a buffer with an even number configured as a double transmit message buffer.

The CC part buffer of a double transmit message buffer is a buffer with the next (after the host part buffer) number.

The accessibility of buffer fields depends on the buffer configuration. All information about buffer field accessibility is summarized in [Table 3-16](#).

Table 3-16. CC Buffer Fields Accessibility

Field	Receive Message Buffer	Receive FIFO Buffer	Single Transmit Message Buffer for Static Segment	Single Transmit Message Buffer for Dynamic Segment	Host Part Buffer of a Double Transmit Message Buffer
Buffer					
R*	RO	RO	RO_NO/WR_CS	WR	RO_NO/WR_CS
PP	RO	RO	RO_NO/WR_CS	WR	RO_NO/WR_CS
NFI	RO	RO	NU	NU	NU
SYNC	RO	RO	NU	NU	NU
STARTUP	RO	RO	NU	NU	NU
FRAME ID	RO_NO/WR_CS	RO	RO_NO/WR_CS	WR	RO_NO/WR_CS
Cycle Counter	RO	RO	NU	NU	NU
Payload Length	RO	RO	RO_NO/WR_CS	WR	RO_NO/WR_CS
Header CRC	RO	RO	RO_NO/WR_CS	WR	RO_NO/WR_CS
DATA	RO	RO	WR	WR	WR
Message Buffer Slot Status Vector	RO	RO	RO	RO	RO
CFG	RO_NO/WR_CS	NU	RO_NO/WR_CS	RO_NO/WR_CS	RO_NO/WR_CS
IFLG	RO	NU	RO	RO	RO
IENA	WR	NU	WR	WR	WR
LOCK	WR	WR	WR	WR	WR
BUFCMT	NU	NU	WR	WR	WR
ChA	RO_NO/WR_CS	NU	RO_NO/WR_CS	RO_NO/WR_CS	RO_NO/WR_CS
ChB	RO_NO/WR_CS	NU	RO_NO/WR_CS	RO_NO/WR_CS	RO_NO/WR_CS
DATUPD	RO_NO/WR_CS	NU	NU	NU	NU
BT	NU	NU	RO_NO/WR_CS	RO_NO/WR_CS	RO_NO/WR_CS
CCFE	RO_NO/WR_CS	NU	RO_NO/WR_CS	RO_NO/WR_CS	RO_NO/WR_CS
TT	NU	NU	RO_NO/WR_CS	WR	RO_NO/WR_CS
VALID	RO_NO/WR_CS	NU	RO	RO	RO
Cycle Counter mask	RO_NO/WR_CS	NU	RO_NO/WR_CS	RO_NO/WR_CS	RO_NO/WR_CS
Cycle Counter Value	RO_NO/WR_CS	NU	RO_NO/WR_CS	RO_NO/WR_CS	RO_NO/WR_CS

Where

RO_NO/WR_CS	Field with host read-only access during normal operation. Host write access only in configuration state
RO	Field with host read-only access
WR	Field with host read/write access
NU	Not used (always hold fixed value – '0'). Fields with host read access only

Configuration Procedure during Configuration State

1. The CC enters the configuration mode after a hard reset or by the CONFIG bit in the MCR0 register being set (see [Section 3.2.3.2.1, “Module Configuration Register 0 \(MCR0\)”](#)). After a hard reset, all message buffers are initialized to as receive message buffers disabled for receive operations (frame ID=0x0). All the bits in the BUFCSnR registers are initialized to 0; the frame ID fields and CCFnR are cleared (to 0).
2. After the CC has entered the configuration state, the host configures a message buffer:
 - The host configures the BUFCSnR register (CFG, IENA, CHA, CHB, BT, CCFE, and TT bits) (see [Section 3.4.1, “Message Buffer Control, Configuration and Status Register”](#)).
 - The host configures the CCFnR register of the message buffer.
 - The host locks a message buffer in accordance with [Section 3.5.3.4, “Active Buffers Locking/Unlocking and Locking Timing”](#).
 - After the message buffer is locked, the host configures the remaining configuration fields of the message buffer in accordance with the configuration principles (see below).
 - The host unlocks the message buffer.
3. After the host has configured the message buffers, it requests the CC to leave the configuration state by setting the CONFIG bit in the MCR0 register to ‘0’. Configuration becomes active after the CC leaves the configuration state.
4. After the CC leaves the configuration state, it goes to the normal mode of operation (see [Section 3.9, “Communication Controller States”](#)).

NOTE

After leaving the hard reset state (the hard reset signal is negated), on the next rising edge of the CC_CLK signal, the CC starts performing an internal initialization procedure (see [Section 3.9.1, “Hard Reset State”](#) and [Section 3.2.3.1.3, “Magic Number Register \(MNR\)”](#)).

During this internal initialization procedure, the CC initializes its internal memory, including the following message buffer configuration/control parameters.

- Frame ID = 0x0
- CCFnR: Cycle Count Mask and Cycle Counter Value fields = ‘0’s
- BUFCSnR:
 - BUFCMT = 0
 - ChA,ChB = 0
 - BT = 0
 - CCFE = 0
 - TT = 0
 - LOCK = 0
 - IFLG = 0
 - VALID = 0
 - IENA = 0

- CFG = 0
- DATUPD = 0

During the internal initialization procedure, the host must not access any CC registers except MNR (see [Section 3.2.3.1.3, “Magic Number Register \(MNR\)”](#)), which acknowledges the finish of the internal initialization procedure.

Message Buffer Configuration Principles

- After a hard reset, all message buffers are initialized as receive message buffers disabled for receive operations (frame ID=0x0). In normal operation, any buffers not configured by the host, during the configuration state, remain receive message buffers disabled for receive operations.
- If a configuration includes FIFO buffers (see [Section 3.2.3.7.1, “FIFO Size Register \(FSIZR\)”](#)), the FIFO starts from message buffer 0 (see [Figure 3-134](#)).
- Buffers of different types can be mixed in the buffer map (receive, single transmit, double transmit, and transmit/receive message buffers that are not used for transmit/receive operations (frame ID=0x0)) (see [Figure 3-134](#)).
- FIFO buffers:
 - must be placed in a continuous subset of message buffers that is uninterrupted by buffers of other types
 - the number of message buffers reserved for the FIFO is determined by the FIFO size register value (see [Section 3.2.3.7.1, “FIFO Size Register \(FSIZR\)”](#))
- The host part buffer of a double transmit message buffer must have an odd number.
- The number of the CC part buffer of a double transmit message buffer must be its host part buffer + 1.
- During the configuration state, only the host part buffer of a double transmit message buffer is available for host read/write configuration operations. Hence, the host part buffer configuration is used for both parts of a double transmit message buffer. The configuration of the host part buffer overwrites the configuration of the CC part buffer.
- Only transmit message buffers can be configured as double transmit message buffers.
- FIFO and receive message buffers are always single buffers.
- CC part buffers of double transmit message buffers have read-only host access. CC part buffers cannot be locked; consequently, the host can read only the BUFCSnR and CCFnR registers of the buffer.

An example of buffer configuration is presented in [Figure 3-134](#).

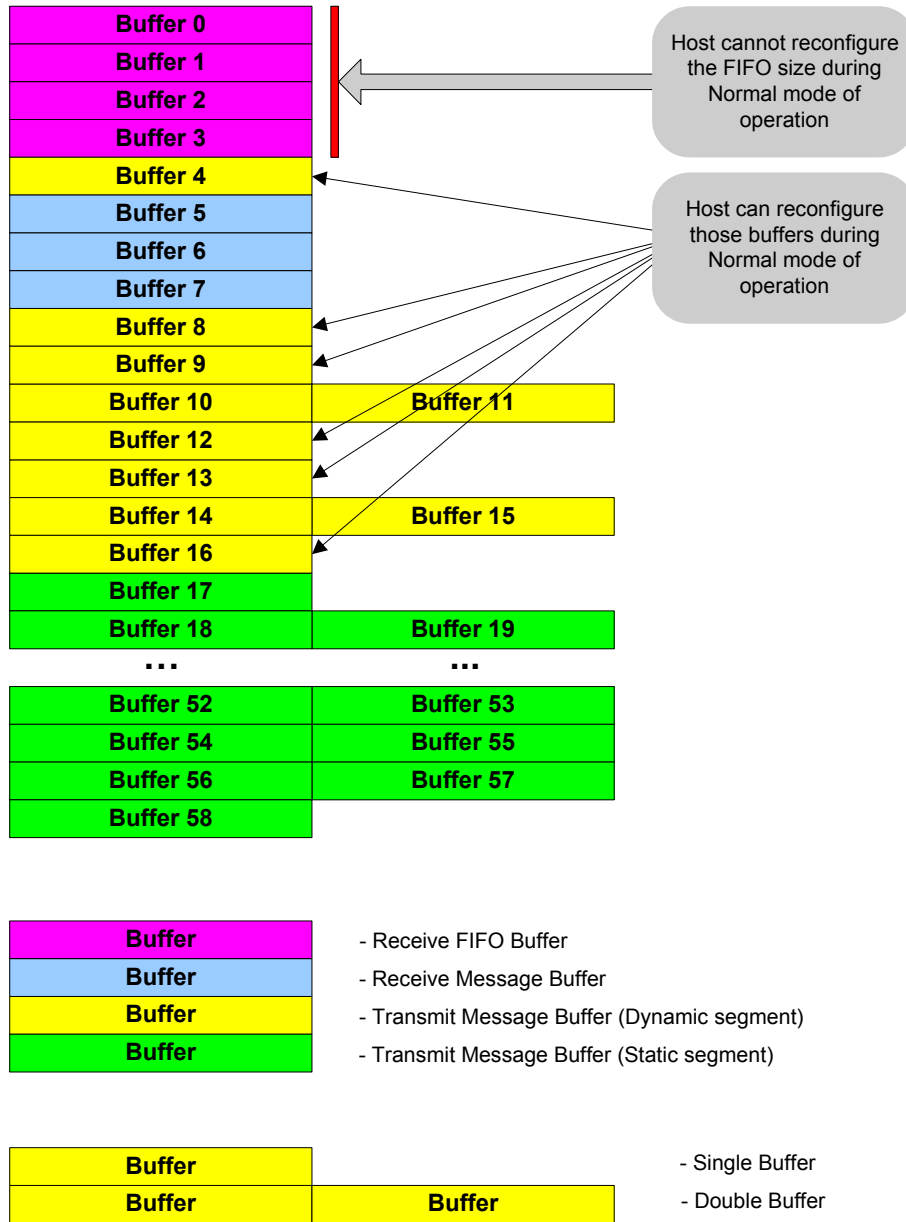

Figure 3-134. Example of a Buffer Configuration

3.5.4.1 Receive Message Buffer Configuration

Receive message buffers can be configured in the configuration state. The configuration must be done in accordance with the configuration procedure and principles. The CFG bits in the BUFCSnR of receive message buffers are 0.

The number of receive message buffers is configurable; however, receive message buffers cannot be placed between FIFO buffers or between the host and CC parts of double transmit message buffers. Receive message buffers cannot be double message buffers.

It is possible to configure from 0 to 59 buffers as receive message buffers.

3.5.4.2 Transmit Message Buffer Configuration

Transmit message buffers can be configured in the configuration state. Single transmit message buffers for the dynamic segment can be configured in the configuration state and during normal operation. The configuration must be done in accordance with the configuration procedure and principles. The CFG bits in the BUFCSnR of transmit message buffers are 1's.

The number of transmit message buffers is configurable; however, transmit message buffers cannot be placed between FIFO buffers or between the host and CC parts of double transmit message buffers.

Transmit message buffers can be configured as single or double transmit message buffers for static and dynamic segments.

If a message buffer is part of a double transmit message buffer:

- The host part buffer must be an even number buffer only.
- The CC part buffer must be an odd number buffer only. The number of the CC part buffer must be its host part buffer number + 1.
- The host must set only a host part buffers configuration in the configuration state. CC part buffers of double transmit message buffers will be initialized by the same configuration automatically.
- In normal mode of operation host operates only with the host part buffers control and status fields. It has read-only accesses to the CC part buffers control and status fields (see [Section 3.4.1, “Message Buffer Control, Configuration and Status Register”](#)).

It is possible to configure from 0 to 59 message buffers as single transmit message buffers, or 29 double transmit message buffers, or different mixtures of single and double transmit message buffers (for example, 15 single transmit message buffers + 22 double transmit message buffers).

3.5.4.3 Receive FIFO Configuration

FIFO Receive buffers can be configured only in the configuration state. First, the host must set the FIFO size register (see [Section 3.2.3.7.1, “FIFO Size Register \(FSIZR\)”](#)).

NOTE

The FIFO is configured only via the FSIZR register.

The host can write the FIFO size register only during the configuration state. The configuration must be done in accordance with the configuration procedure and principles.

If a configuration includes FIFO buffers, message buffer 0 must be the first FIFO buffer (see [Figure 3-134](#)). The subset of FIFO buffers must be contiguous.

It is possible to configure up to 59 message buffers as FIFO receive message buffers.

3.5.5 Buffer Reconfiguration in the Normal State of Operation

Reconfiguration procedure during the normal state of operation:

The host must follow the configuration principles and procedure as well as reconfiguration principles, while reconfigures the message buffers during normal operation.

Reconfiguration principles:

1. Only single transmit message buffers for dynamic segment (STBDS) are reconfigurable in normal operation.
2. States and parameters that are reconfigurable:
 - Parameters of STBDS accessible for host write operations (see [Section](#) , “Receive, receive FIFO, and transmit message buffers are accessible to the host MCU only through the active receive, active transmit, and active receive FIFO buffers.” and [Section 3.4.1](#), “Message Buffer Control, Configuration and Status Register”).
3. Buffers, states and parameters that are not reconfigurable:
 - FIFO size
 - Double transmit message buffers
 - Receive message buffers
 - Buffers from transmit message buffers to receive message buffers, and vice versa
 - All the filtering parameters (channel filters configuration, frame ID filters configuration (except single transmit message buffers for dynamic segment), message ID filters configuration and masks, message buffer filtering configuration)
 - Buffers cannot be reassigned from static to dynamic segment, or vice versa.
 - FIFO
 - Buffers cannot be reconfigured from single to double transmit message buffers, or vice versa.
 - Buffers assigned to the static segment are not reconfigurable

[Figure 3-135](#) shows how CC buffers can be configured and reconfigured during the configuration state, and reconfigured during the normal state of the CC:

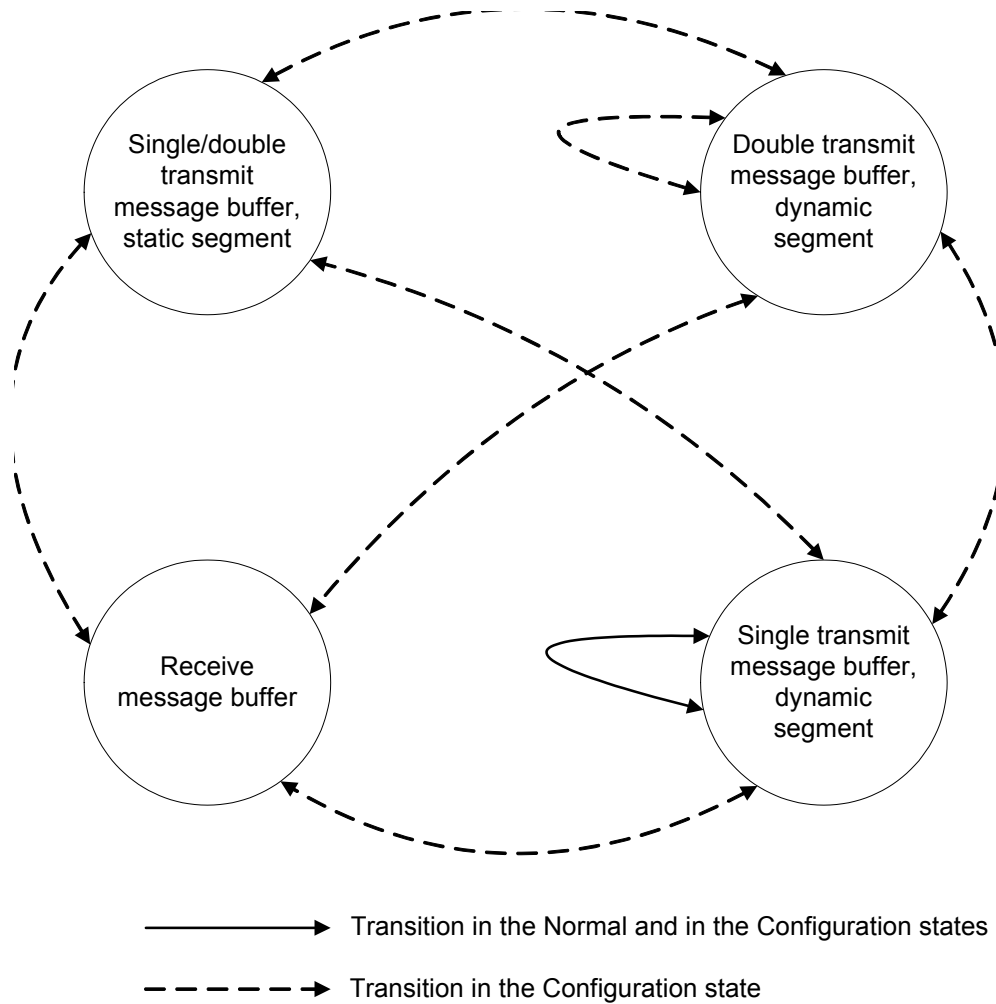

Figure 3-135. Transition Scheme Between Different Buffer Types Depending on Operational Mode of CC

3.5.6 Message Buffer Operations

The main principles of the host and the CC data exchange are as follows.

- The host has full control over the CC.
- After the configuration step is performed by the host, the CC can run the FlexRay protocol. The CC does not require any additional support from the host for operation in a cluster without faults and disturbances.
- Data exchange is based on access requests and acknowledge flags.

The host and the CC provide a set of transmit/receive operations for managing data flow between a FlexRay network and the host.

3.5.6.1 Data collection during Receive Operation

Frames are stored in the CHI if there is at least one receive message buffer or FIFO receive buffer configured. Therefore, it actively participates in the internal buffer filters matching process, which takes

place every time the communication controller receives a semantically valid and syntactically correct frame.

An example of operations during a frame reception is shown on the [Figure 3-136](#).

3.5.6.1.1 The Host Operations during Reception

After every successful frame reception, the CC sets the flag IFLG of a matching buffer. This flag indicates that a frame has been received and stored in a buffer, and the host can read it to empty the buffer for the next reception. All IFLG bits are logically OR'ed and connected to the host interrupt line. The host receives an interrupt if at least one IFLG is set and not masked by the appropriate IENA bit in the BUFCSnR register.

To read a receive message buffer the host must perform the following steps:

1. Process an interrupt by reading the ISR registers, if necessary. or check the IFLG bits of receive message buffers.
2. Locate one IFLG interrupt source register by reading the receive message buffer interrupt vector register (see [Section 3.2.3.6, “Interrupt and Error Signaling Related Status Registers”](#)).
3. Send a lock request (write LOCK bit with the value '1') for the corresponding message buffer, to make it accessible through the active receive message buffer.
4. Wait for lock acknowledge (LOCK bit reads as value '1').
5. Read the active receive message buffer.
6. Send an unlock request for the message buffer.

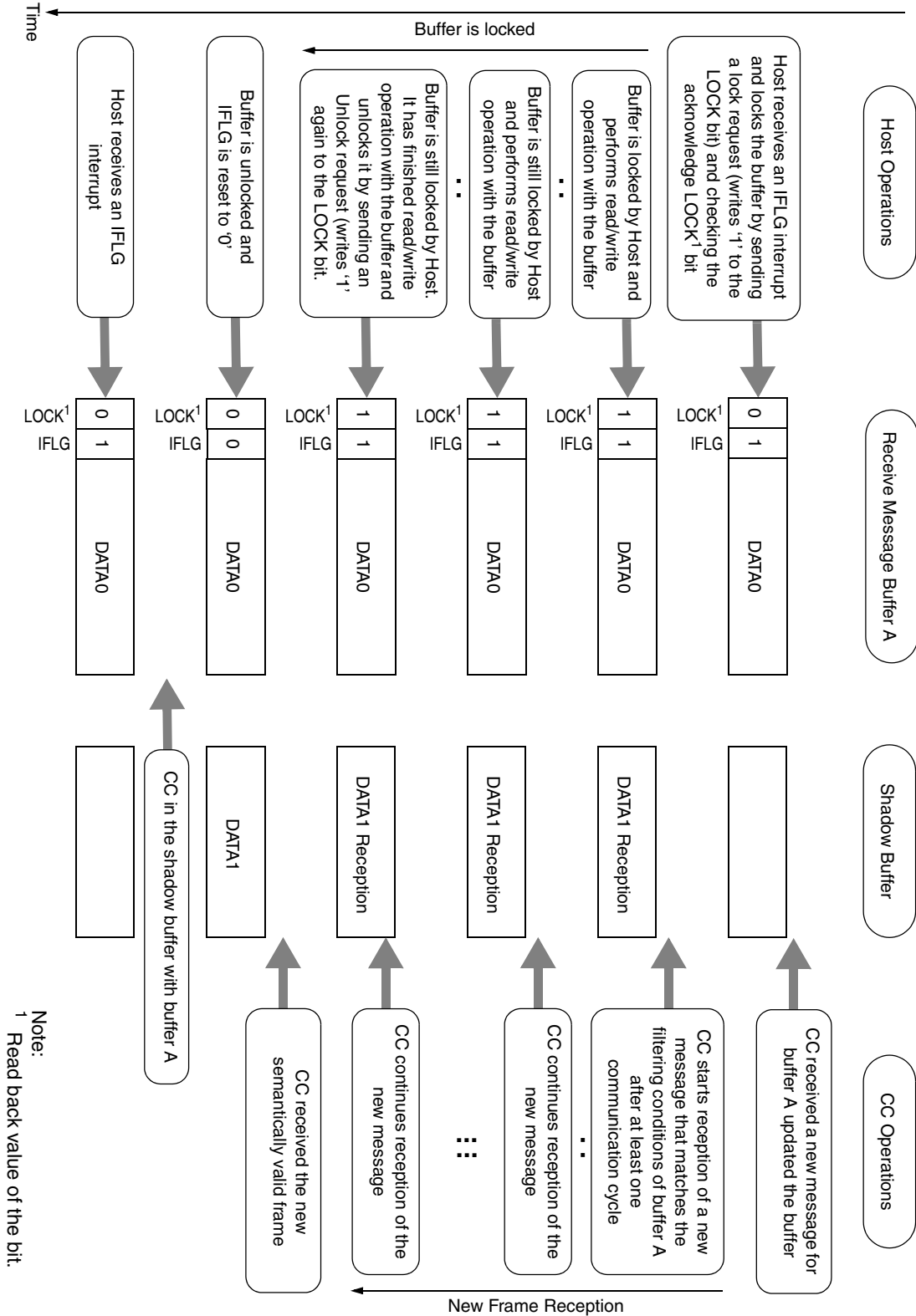

Figure 3-136. Operations During a Frame Reception

3.5.6.1.2 CC Operations during Reception

The CC receives every frame to a shadow message buffer first, as shown in [Figure 3-136](#).

NOTE

A frame received in slot n and stored in a configured message buffer or FIFO is accessible to the host, through the CHI, $16 \mu\text{T}$ after the start of slot $n+1$.

The CC performs a filtering process based on filter configuration. This process takes place every time the CC receives a semantically valid and syntactically correct frame. In this process, the CC sequentially compares all the receive message buffers filters to the received ones. The first message buffer matching all the filtering requirements will be updated with the new frame. The matching message buffer will be overwritten, if the message buffer was already full ($\text{IFLG} = 1$). If a received frame does not match the filtering fields of any receive message buffer, it will be compared with the FIFO filters. If a frame matches the FIFO filtering parameters, it will be stored in the FIFO; otherwise, it will be ignored. The CC ignores invalid frames and does not store them in buffers.

The received frame will be stored in the first matching receive message buffer. The search engine starts after the end of the FIFO, or at message buffer 0 (if no FIFO is configured), and searches upwards. Thus, if there are two receive message buffers matching the received frame, the frame will always be stored in the buffer with the lower buffer index. The CC does not check which buffer fits the frame best. Thus, if a message buffer holds a filtering subset of another message buffer, that message buffer (with the filtering subset) must be located at the lower message buffer index. The application must manage this.

The matching message buffer will not be updated if it is still locked. If the message buffer is locked after reception, it will be updated as soon as it is unlocked. If the buffer is locked for more than one communication cycle and, if the frame, which matches that message buffer filtering, is received twice during this period, the buffer will be updated with the newer frame, as soon as it is unlocked, and a frame lost error will be raised to the host (see [Section 3.2.3.6.3, “CHI Error Register \(CHIER\)”](#)). The corresponding IFLG bit (message buffer is full) is set every time the message buffer is updated, and, if enabled, a receive interrupt is generated.

In the case of locking, when the host may lock one receive message buffer, the CC has two shadow message buffers per channel to continue frame reception targeted for any receive message buffers including the locked one.

NOTE

During the filtering process, the CC must check the payload length field of a received frame before the CC applies message ID filtering. If the payload length of a received frame is too small to hold the full message ID value, the CC performs the message ID filtering with the default message ID value (0x0).

3.5.6.2 Data Collection during Transmit Operation

Some or all of the message buffers can be configured as transmit message buffers via the BUFCSnR register sets (see [Section 3.4.1, “Message Buffer Control, Configuration and Status Register”](#)). The configuration of transmit message buffers must comply with the buffer configuration procedure and

principles. The CC handles transmit operations differently during the static and dynamic segments of transmission; it also handles single and double transmit message buffers differently. For transmission, the CC uses data from configured and committed transmit message buffers only.

The host submits a frame for transmission by committing a message buffer for transmission (BUFCMT bit) and by subsequent unlocking of the transmit message buffer. The transmit message buffer remains valid for transmission until its VALID bit = 1.

To prepare a transmit message buffer for transmission, the following steps must be performed.

1. Configure the message buffer as a transmit message buffer in accordance with the buffer configuration procedure and principles.
2. Lock the corresponding message buffer, to make it accessible in the active transmit message buffer. Buffer locking must be done in accordance with the locking/unlocking procedure and principles
3. Write/read the active transmit message buffer to change or update the message buffer content.
4. Commit the message buffer for transmission, by setting the BUFCMT bit to '1'.
5. Unlock the message buffer.

Commitment-to-transmission time for single and double transmit message buffers:

To transmit a frame in slot n, the host must commit and unlock the buffer:

- Static segment transmit message buffer: 4 μ T before the beginning of slot n-1 or the network idle time (NIT).
- Dynamic segment transmit message buffer: 4 μ T before the beginning of slot n-1 or the network idle time (NIT).

Static segment:

For the static segment, if there are several frames pending for transmission, the frame with the ID corresponding to the next sending slot is selected for transmission. The CC checks other filtering fields of those messages. If several frames are suitable for current static slot transmission, the CC performs an internal arbitration.

The CC transmission procedure is described in detail in the frame processing section of the PWD. The most important points are as follows.

- Only valid frames (VALID bit = 1) can be transmitted by the CC.
- If there are valid frames with the same frame ID, the CC checks their filter fields. If two or more of them match the conditions of the transmit slot, the message buffer with the lowest message buffer number wins the internal arbitration.
- If two buffers are assigned to the same static slot but to different transmission channels, the CC transmits them simultaneously on assigned channels during transmission of that static slot.
- If a message buffer was committed for transmission (BUFCMT = 1) it becomes valid (VALID = 1) after buffer unlock operation, and the host cannot lock it until it is transmitted at least once.

The CC changes the following bits, if a message from a message buffer has been sent.

- IFLG
- BUFCMT
- VALID (depending on the TT bit of the BUFCsnR register — see [Section 3.4.1, “Message Buffer Control, Configuration and Status Register”](#))

Dynamic segment

In the dynamic segment, if several valid frames are pending within the interface, the frame with the highest priority (lowest frame ID) is selected next.

The CC transmission procedure is described in detail in the frame processing section of the PWD document. The most important points are as follows.

- In the dynamic segment, different minislot sequences are possible on both channels (concurrent sending of different IDx on both channels).
- Pending frames are selected in accordance with their identifier and their filter configuration.
- Frames overlapping with the network idle time (NIT), defined by the NITCR (see [Section 3.2.3.3.18, “Network Idle Time Configuration Register \(NITCR\)”](#)), will be not transmitted.
- If there are two or more transmit message buffers with the same identifier, the message buffer with the lowest number wins the internal arbitration and will be transmitted; the remaining message buffer(s) with matching filters will be removed from the arbitration process until the next communication cycle.
- If a message buffer was committed for transmission (BUFCMT= 1) it becomes valid (VALID = 1) after the buffer unlock operation. The host cannot lock it until it is transmitted; this prevents changing of a message buffer’s fields, while it is waiting to be transmitted.
- Only valid frames (VALID bit = 1) can be transmitted by the CC.
- Only identifiers that are higher than the highest static identifier are allowed for the dynamic segment.
- If there are valid frames with the same frame ID, the CC must check their filter fields. If two or more of them match the conditions of the transmit slot, the message buffer with the lowest address wins the internal arbitration.
- The CC does not transmit null frames in the dynamic segment.
- If two message buffers are assigned to the same dynamic slot but to different transmission channels, the CC transmits them on the same minislot number and assigned channels during transmission of that dynamic slot.

The CC changes the following bits if the message buffer has been sent.

1. IFLG
2. BUFCMT
3. VALID (depending on the TT bit of the BUFCsnR register — see [Section 3.4.1, “Message Buffer Control, Configuration and Status Register”](#))

3.5.6.2.1 Single Transmit Message Buffer Data collection during Transmit Operation

The host can configure some message buffers of the CC as single transmit message buffers. If there is at least one transmit message buffer configured, or the sync frame register value (see [Section 3.2.3.3.29](#), “Sync Frame Register (SYNCFR)”) is not 0x0, the CC can actively transmit frames out of the connected FlexRay network.

To configure a single transmit message buffer, the following next steps must be performed.

1. Configure the message buffer as a transmit message buffer, in accordance with the configuration procedure and principles.
2. Set the message buffer type bit (BT) to 0 — single transmit message buffer.

After a buffer is configured as a single transmit message buffer and a CC enters the normal mode of operation, The host can start preparation and commitment of frames for transmission. [Figure 3-137](#) shows an example of host and CC operation on a single transmit message buffer during frame transmission in normal operation.

As shown in [Figure 3-137](#), The host sends a lock request for a message buffer and always checks for the lock request acknowledge bit LOCK to be a ‘1’ before it starts to update the message buffer content (see [Section 3.5.3.4](#), “Active Buffers Locking/Unlocking and Locking Timing” and [Section 3.2.3.6.3](#), “CHI Error Register (CHIER)” for more information).

After a transmit message buffer is locked, the host can update it, via the active transmit message buffer, and can commit it to transmission by setting the BUFCMT bit to ‘1’ and unlocking the message buffer.

After transmission, the CC sets the IFLG bit of a message buffer, and clears BUFCMT. The CC changes the VALID bit after transmission depending on the TT bit.

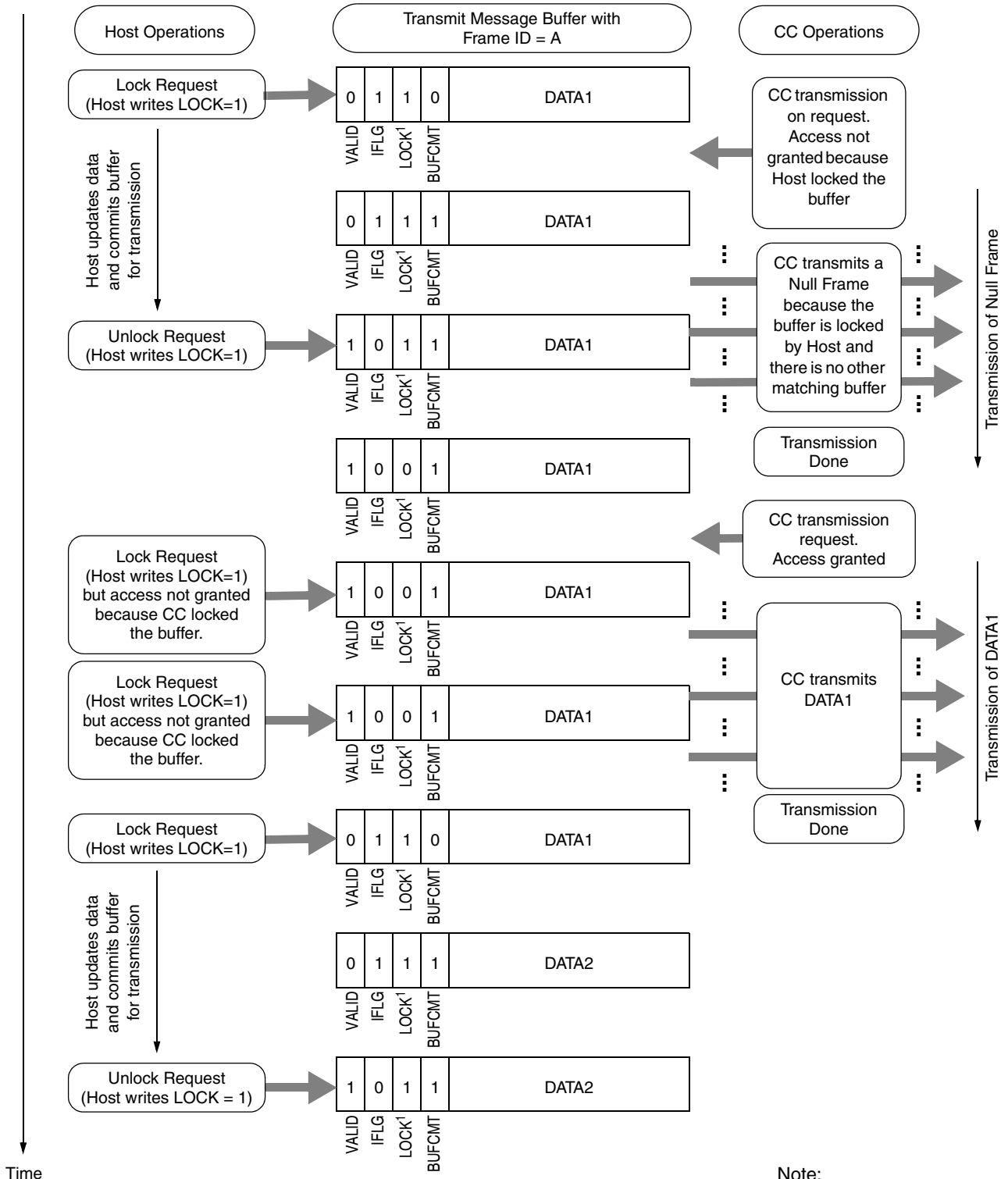

Figure 3-137. Operations with a Single Transmit Message Buffer during an Event Type of Transmission for a Static Segment

3.5.6.2.2 Doubled Buffer Data collection during Transmit Operation

The host can configure some message buffers of the CC as double transmit message buffers. If there is at least one double transmit message buffer configured, then the CC can actively transmit frames out of the connected FlexRay network.

To configure a double transmit message buffer (Figure 3-138), the follow steps must be performed.

1. Configure the even number message buffer as a transmit message buffer, in accordance with the configuration procedure and principles.
2. Set the message buffer type bit BT (see Section 3.4.1, “Message Buffer Control, Configuration and Status Register”) to 1 — host part buffer of double transmit message buffers (configuration is copied to the CC part buffers automatically).

The Figure 3-139 shows an example of a double transmit message buffer data collection during the state driven transmit operation in normal operation.

The Figure 3-140 shows an example of a doubled transmit message buffer data collection during the event driven transmit operation.

NOTE

When the CC transmits a null frame, it does not change the BUFCSnR registers of the buffers.

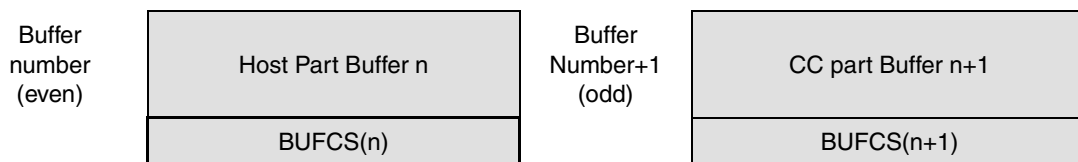

Figure 3-138. Double Transmit Message Buffer Structure

Host Operations with a Double Transmit Message Buffer during Transmission

The host can perform the following operations on a double transmit message buffer.

- Lock buffer for reading and/or modifying.
- Read message buffer slot status vector, data and configuration.
- Write data.
- Commit and unlock for transmission.

Main principles of the host operations with double transmit message buffers:

- The host always operates with host part buffers.
- The host can perform operations with host part buffers independent of CC transmit operations from the CC part buffers.
- Data exchange is based on access requests and acknowledge flags.
- The host and the CC operate only with configured buffers that have frame ID field not equal to '0'.
- The addresses of the host part buffers do not change during normal operation.
- The host has read-only access to the CC part buffer BUFCSnR registers.

- The host operates with a double transmit message buffer in the same way as it does with a single transmit message buffer.
- The host can receive an IFLG interrupt after transmission of a committed CC part buffer.
- The host cannot lock a host part buffer (read value of the LOCK= 0) during swap and copy procedures.
- The host part buffer of a double transmit message buffer cannot be locked (read back value of the LOCK= 0), if the host has committed the host part buffer for transmission but the BUFCMT bit of the CC part buffer is still '1' (a frame has not yet been transmitted).
- if the host has committed a host part buffer of a double message buffer for transmission, the CC performs an atomic swap of the host part and CC part buffers including the BUFCsnR registers of the host and the CC part buffers, and starts a copy process.

CC Operations with a Double Transmit Message Buffer During Transmission

The CC performs the following operations on a double transmit message buffer.

1. Lock buffer for transmission.
2. Update the message buffer slot status vector of the host and the CC part buffers.
3. Swap host and CC part buffers after commitment for transmission.
4. Copy the CC part buffer to the host part buffer during commitment for transmission. The CC copies the following fields from a CC part buffer of a double transmit buffer to a host part buffer (see [Section 3.5, “Message Buffer Handling and Operations”](#)):
 - R*
 - PP
 - Frame ID
 - Payload length
 - Header CRC
 - Data[0:31]
 - Message buffer slot status vector

Main principles of CC operations with double transmit buffers:

- The CC may perform transmit operations from the CC part buffers while the host updates the host part buffers.
- Data exchange is based on access requests and acknowledge flags.
- The host and the CC operate only with configured buffers that have frame ID fields not equal to '0'.
- The numbers of the CC part buffers do not change during normal operation.

As it is presented in [Section 3.5.6, “Message Buffer Operations”](#), host operations on a host part of a double transmit message buffer are the same as they are on a single transmit message buffer. However, CC operations with host part and CC part buffers are different.

Table 3-17. Double Transmit Message Buffer Data Collection with State Driven Transmit Operation

Time Point	Host Operations	CC Operations
1	The host sends a lock request to a host part buffer of a double transmit message buffer (it writes LOCK='1') and receives a request acknowledge (read back value of the LOCK='1').	–
2	The host part buffer is locked. The host updates the buffer contents.	The CC starts frames transmission and sends a buffer lock request for CC part buffer to transmit the frame this buffer holds.
3	The host part buffer is locked. The host updates the buffer contents.	The CC locked the CC part buffer and transmits the frame from it
4	The host part buffer is locked. The host finished data update (buffer holds the DATA1), committed the buffer for transmission (BUFCMT='1') and sent an unlock request (it writes again LOCK='1')	The CC finished transmission and updates the BUFCMT, VALID and IFLG bits of the CC part buffer
5	Unlock granted.	The CC clears the IFLG bit of the host part buffer to '0' and sets the VALID bit. The CC performs an atomic swap of the host part and CC part buffers including the BUFCSnR registers and starts a copy process.
6	–	The atomic swap of the host part and CC part buffers is done. The CC starts the copy process from the new CC part buffer to the host part buffer. BUFCMT bit of the host part buffer is '1' until those processes are finished (The host cannot lock the host part buffer).
7	–	The CC continues the copy process and starts frames transmission. The CC sends a buffer lock request for CC part buffer to transmit the frame this buffer holds.
8	The host sends a lock request to a host part buffer of a double transmit message buffer (it writes LOCK='1') but does not receive a lock request acknowledge (read back value of the LOCK='0') due to the copy process running.	The CC continues the copy process. The CC locked the CC part buffer and transmits the frame from it.
9	–	The CC transmits the frame from the CC part buffer. The CC finished the copy process (The host can lock the buffer).
10	The host sends a lock request to a host part buffer of a double transmit message buffer (it writes LOCK='1') and receives a request acknowledge (read back value of the LOCK='1') and has starts to update data in the host part buffer.	The CC transmits the frame from the CC part buffer.

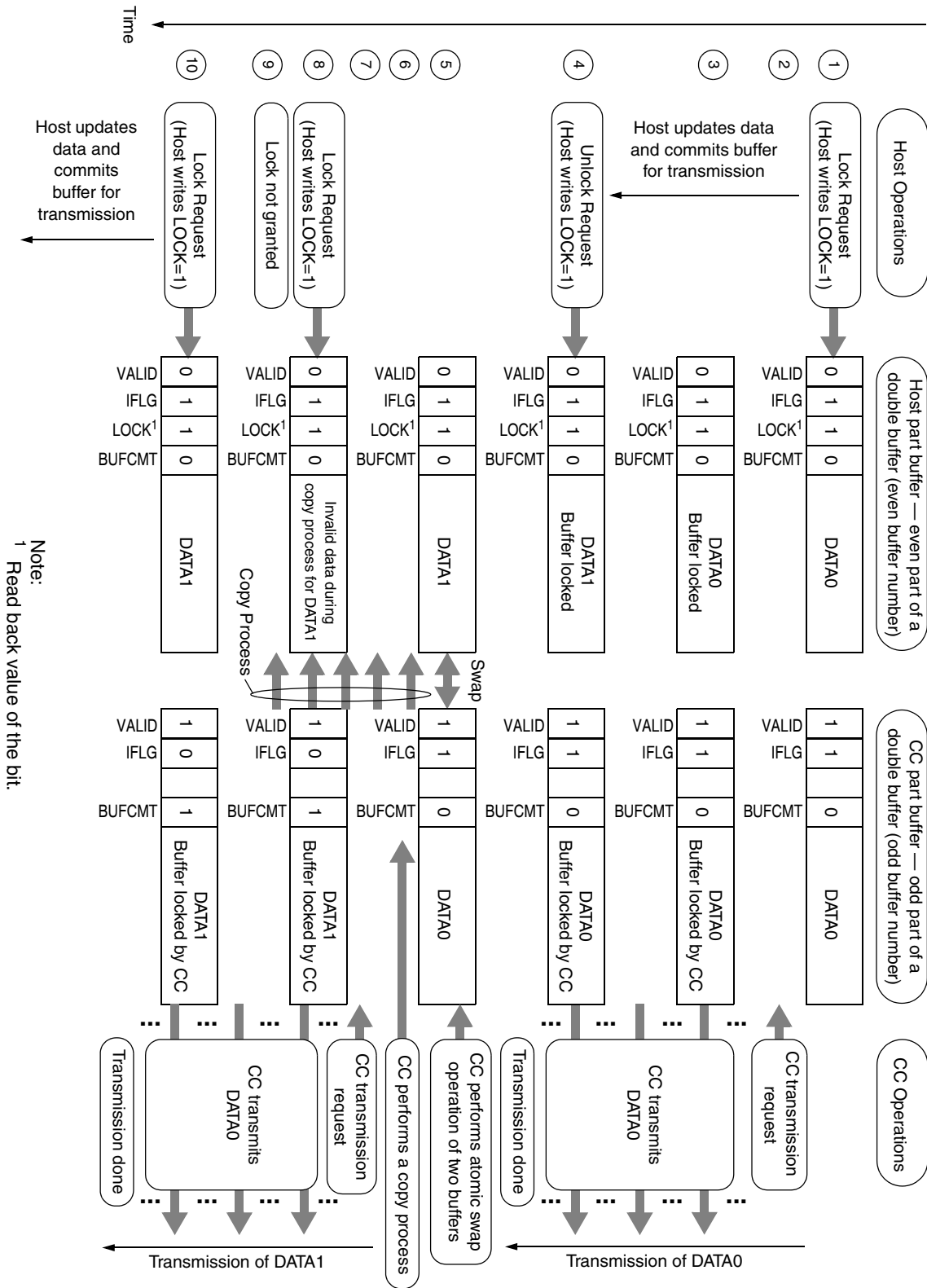

Figure 3-139. Doubled Buffer Data Collection with State Driven Transmit Operation

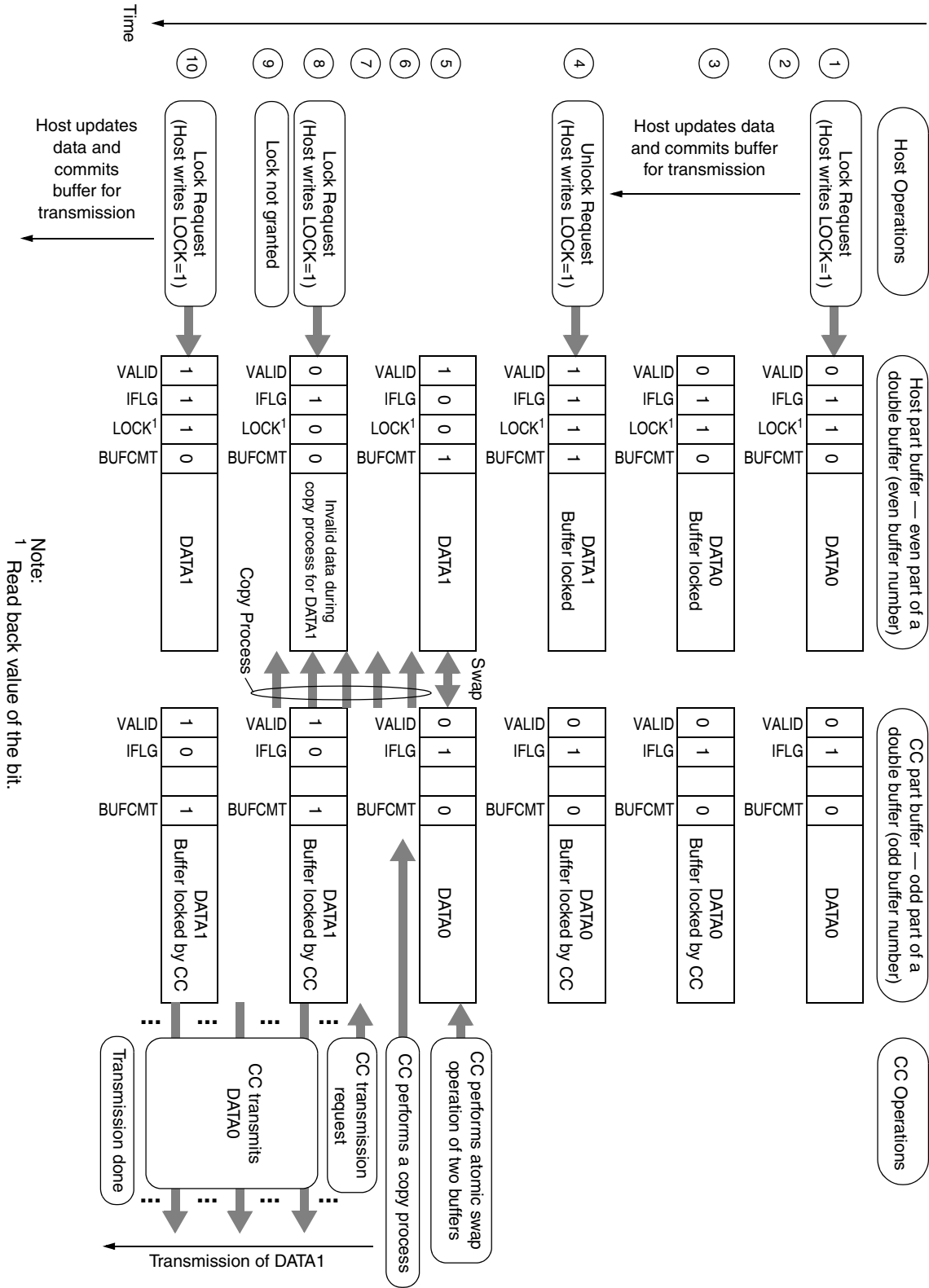

Figure 3-140. Doubled Buffer Data collection with Event Driven Transmit Operation

Table 3-18. Double Transmit Message Buffer Data Collection with Event Driven Transmit Operation

Time Point	Host Operations	CC Operations
1	The host sends a lock request to a host part buffer of a double transmit message buffer (it writes LOCK='1') and receives a request acknowledge (read back value of the LOCK='1').	The Valid bit of the CC part buffer is '0' – data is not valid and the CC does not transmit frame containing data from this buffer
2	The host part buffer is locked. The host updates the buffer contents.	The Valid bit of the CC part buffer is '0' – data is not valid and the CC does not transmit frame containing data from this buffer
3	The host part buffer is locked. The host updates the buffer contents.	The Valid bit of the CC part buffer is '0' – data is not valid and the CC does not transmit frame containing data from this buffer
4	The host part buffer is locked. The host finished data update (buffer holds the DATA1), committed the buffer for transmission (BUFCMT='1') and sent an unlock request (it writes again LOCK='1')	The Valid bit of the CC part buffer is '0' – data is not valid and the CC does not transmit frame containing data from this buffer
5	Unlock granted.	The CC clears the IFLG bit of the host part buffer to '0' and sets the VALID bit. The CC performs an atomic swap of the host part and CC part buffers including the BUFCSnR registers and starts a copy process.
6	–	The atomic swap of the host part and CC part buffers is done. The CC starts the copy process from the new CC part buffer to the host part buffer. BUFCMT bit of the host part buffer is '1' until those processes are finished (The host cannot lock the host part buffer).
7	–	The CC continues the copy process and starts frames transmission. The CC sends a buffer lock request for CC part buffer to transmit the frame this buffer holds.
8	The host sends a lock request to a host part buffer of a double transmit message buffer (it writes LOCK='1') but does not receive a lock request acknowledge (read back value of the LOCK='0') due to the copy process running.	The CC continues the copy process. The CC locked the CC part buffer and transmits the frame from it.
9	–	The CC transmits the frame from the CC part buffer. The CC finished the copy process (The host can lock the buffer).
10	The host sends a lock request to a host part buffer of a double transmit message buffer (it writes LOCK='1') and receives a request acknowledge (read back value of the LOCK='1') and has starts to update data in the host part buffer.	The CC transmits the frame from the CC part buffer.

3.6 Receive FIFO Function

Some or all of the message buffers can be configured as a receive first-in-first-out (FIFO) system.

The FIFO always starts at message buffer 0 and can be configured to a maximum of 59 message message buffers by means of the FIFO size register (see [Section 3.2.3.7.1, “FIFO Size Register \(FSIZR\)”](#)).

Every incoming frame not matching any receive filter, but matching the programmable FIFO filters, is stored in the FIFO buffer system. In this case, the received frame and its message buffer slot status vector are stored in the next FIFO message buffer, including. There are two status bits in ISR0 (see the RFNEIF and RFOIF bits in [Section 3.2.3.6.6, “Interrupt Status Register 0 \(ISR0\)”](#)): one shows that the receive FIFO is not empty; the other shows that a receive FIFO overrun has been detected. Interrupts are generated, if interrupts are enabled.

NOTE

- The CC does not store null frames and invalid frames in FIFO.
- If the CC has two channels configured, then, during the static part of transmission, the CC stores in the FIFO first the frame received on channel A, and then the frame received on channel B. All FIFO filtering conditions must match for both received frames.

There are two internal (not host accessible) index registers associated with each FIFO. The PUT index register (PUTIDX) is used as an index to the next available location in the FIFO buffer system. When a new frame is received, it is written into the message buffer addressed by the PUTIDX register; the PUTIDX register is then incremented, to address the next message buffer. If the PUTIDX register is incremented past the highest FIFO message buffer, the PUTIDX register is reset to 0. The GET index register (GETIDX) is used to address the next FIFO buffer to be read. The GETIDX register is incremented when unlocking one of the receive FIFO buffers. The FIFO buffer system is completely filled when the PUT pointer (PUTIDX) reaches the value of the GET pointer (GETIDX). New incoming frames cannot be stored in the FIFO. The FIFO overrun flag is set at the end of this frame if no error has occurred. A receive FIFO non empty status is detected when the PUTIDX register differs from the GETIDX register. This indicates that there is at least one received frame in the FIFO buffer system.

The PUTIDX register and the GETIDX register cannot be accessed by the host.

The FIFO empty, FIFO not empty, and FIFO overrun situations are explained in [Figure 3-141](#).

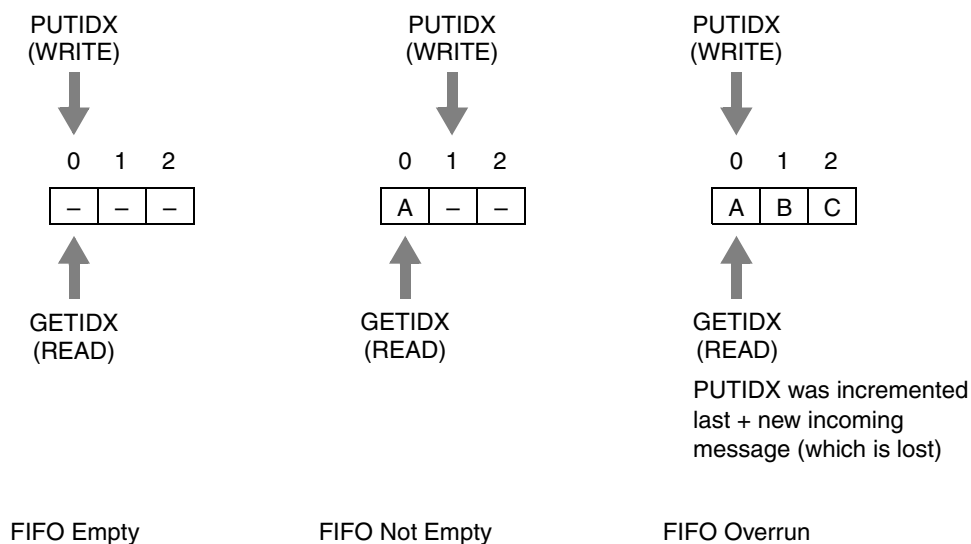

Figure 3-141. FIFO Status (Empty, Not Empty, Overrun) — Example of FIFO with Three Message Buffers

To read a receive FIFO buffer, the host must lock the FIFO buffer by sending a lock request (LOCK='1') to message buffer 0. When a FIFO buffer is locked (read back value of the LOCK='1'), the message buffer addressed by GETIDX appears in the active receive FIFO buffer. After reading, the FIFO buffer must be unlocked, and the GETIDX pointer is incremented.

The complete set of FIFO acceptance/rejection filters consists of the following registers (see [Section 3.2.3.8, “Filtering Related Registers”](#)).

Two filter sets are available for FIFO filtering:

- One FIFO acceptance filter set, comprising:
 - FIFO acceptance filter message ID value register
 - FIFO acceptance filter message ID mask register
- One FIFO rejection filter set, comprising:
 - FIFO rejection filter frame ID value register
 - FIFO rejection filter frame ID mask register
- The channels from which the received frame will be accepted or rejected by the FIFO acceptance/rejection filters are specified in [Section 3.2.3.8.7, “FIFO Acceptance/Rejection Filter Channel Register \(FAFCHR\)”](#).

The FIFO acceptance filter value registers define the acceptable pattern of the frame to be received. The FIFO acceptance filter mask registers specify which of the corresponding bits are marked ‘don’t care’ for acceptance filtering.

The FIFO rejection filter value registers define the acceptable pattern of the frame to be rejected. The FIFO rejection filter mask registers specify which of the corresponding bits are marked ‘don’t care’ for rejection filtering.

If acceptance and rejection filter are configured to match the same identifier, the frame will be rejected.

NOTE

- The content of the FIFO is not reset by entering, being in, or leaving the configuration state. Therefore, if the CC has stored any messages in the FIFO, and has entered the configuration state without reading those messages, and has returned to normal operation, then those messages will remain in the FIFO.
- The CC automatically updates the BUFCSnR registers of the FIFO buffers to 0x0 values when the CC enters the configuration state for the first time.
- The host must clear buffer control flags CFG, IFLG, and IENA (write 0x0000 to the buffer control register) of a message buffer that has already been in use or that has already been configured, before the host may extend the FIFO (alter the FIFO size) to include that message buffer in the FIFO. Failing to do so will result in invalid indications in the RBIVEC/TBIVEC registers (see [Section 3.2.3.6.1, “Receive Buffer Interrupt Vector Register \(RBIVECR\)”](#) and [Section 3.2.3.6.2, “Transmit Buffer Interrupt Vector Register \(TBIVECR\)”](#)), i.e. RBIVEC/TBIVEC

will still indicate asserted IFLG bits for the message buffer that has been included in the FIFO.

3.7 Host Controller Interfaces

The FlexRay communication controller can be connected and controlled by two types of microcontrollers through the CC MCU interface. Two pins, IF_SEL0 and IF_SEL1, configure the interface for the type of MCU. The MCU type is selected by IF_SEL0 and IF_SEL1 inputs as shown in [Table 3-19](#).

Table 3-19. FlexRay CC MCU Interface Configuration

Mode	IF_SEL0	IF_SEL1
Unsupported	0	0
HCS12	0	1
AMI	1	0
Unsupported	1	1

When it leaves the hard reset state, the CC latches the values of the IF_SEL0 and IF_SEL1 signals and configures the interface for the type of MCU accordingly. The CC does not analyze IF_SEL0 and IF_SEL1 after it has left the hard reset state (see [Section 3.9.1, “Hard Reset State”](#)).

NOTE

If the CC senses the unsupported mode on its IF_SEL pins, it stops all internal operations, does not perform/respond on any host transactions, stays in the configuration mode, and does not integrate into the communication process. The following steps must be taken to select a correct MCU interface mode.

1. IF_SEL0, IF_SEL1 must be set to the AMI or HCS12 mode.
2. The hard reset signal of the CC must be asserted again.

3.7.1 MFR4200 Asynchronous Memory Interface

The MFR4200 asynchronous memory interface is shown in [Figure 3-142](#). This interface has the following characteristics and features:

- Data exchange in AMI mode is controlled by the CE#, WE# and OE# signals.
- The MFR4200 AMI is implemented as an asynchronous memory slave module, thus enabling fast interfacing between the CC and a variety of microcontrollers.
- The MFR4200 AMI decodes its internal registers addresses with the help of the chip select signal CE# and the address lines A[9:1].

NOTE

The address space from 0x0400 to 0x1FFF is reserved. Reading this address space results in data 0x0000, while writing will not change the memory. Reading or writing this address space will set the ILLADR bit in CHIER.

- The AMI module accepts only 16-bit wide (word) transactions. It does not have byte select lines and, thus, does not recognize 8-bit wide accesses. Therefore, it does not indicate errors in the event of 8-bit transactions.
- The WE# signal indicates the direction of data transfer for a transaction.
- The OE# signal enables the AMI data output to a microcontroller during read transactions.
- INT_CC# is an interrupt line that can be used for requesting, by means of the internal interrupt controller, a service routine from a host controller.
- The MFR4200 AMI module does not support burst transactions.

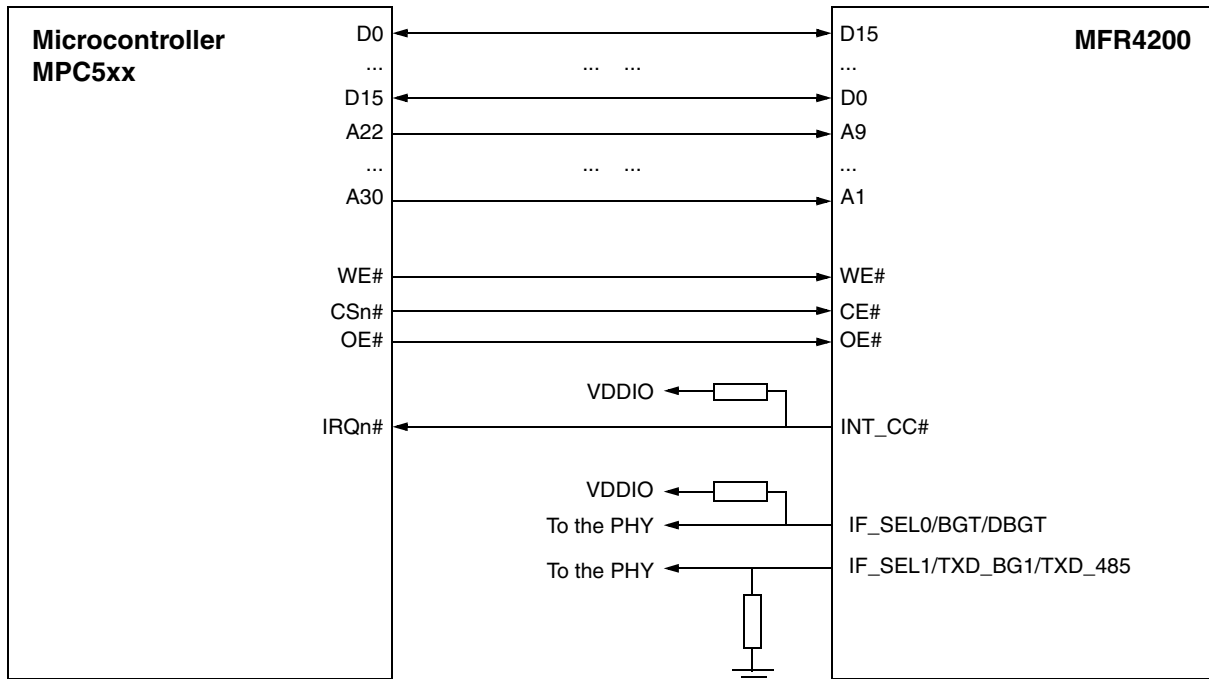

Figure 3-142. Connecting MFR4200 to MPC5xx Using the AMI (Example)

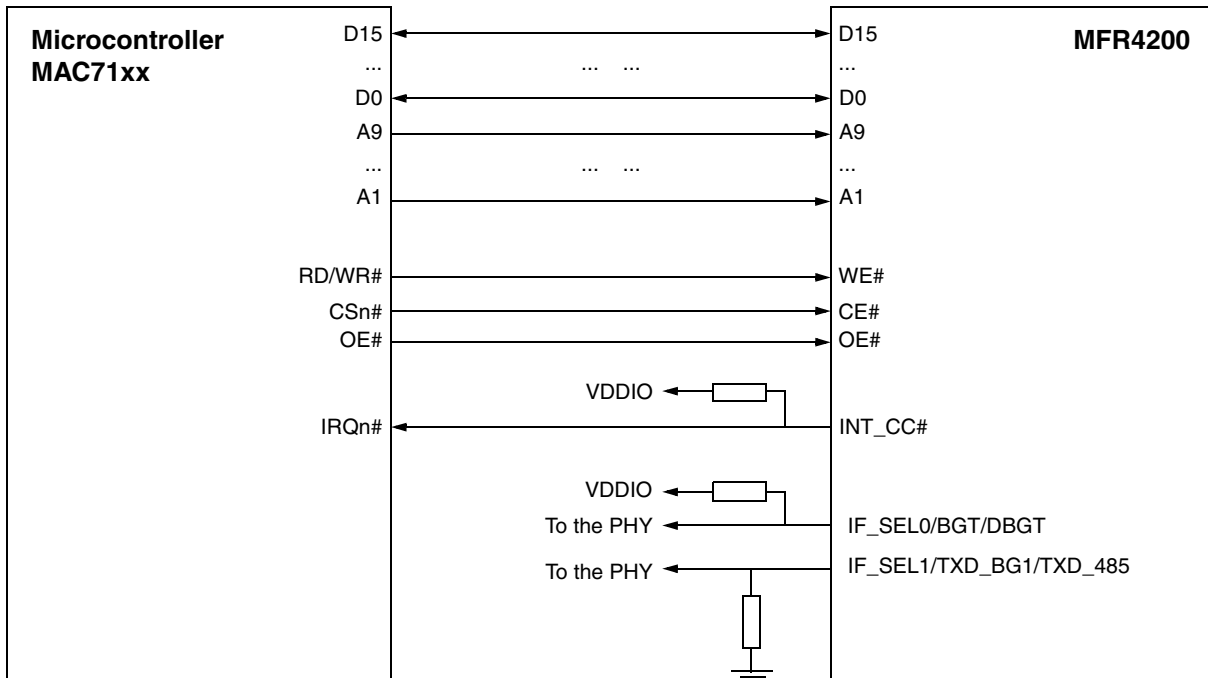

Figure 3-143. Connecting MFR4200 to MAC71xx Using the AMI (Example)

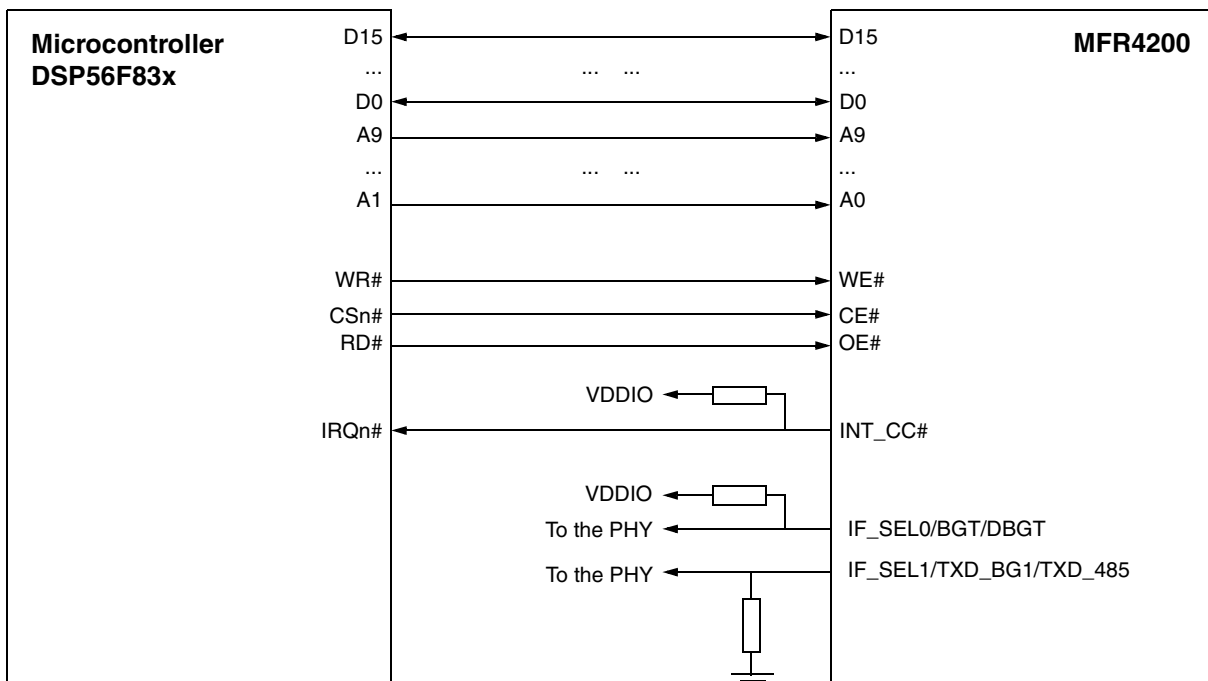

Figure 3-144. Connecting MFR4200 to DSP56F83x (Hawk) Using the AMI (Example)

3.7.1.1 AMI Interface Signals and Pins Description

Table 3-20. AMI Interface Signals and Pins Description

Signal name	MCU External Bus and Memory Controller Pin		FlexRay CC MCU Interface Pin		Function Description
	Name	I/O	Name	I/O	
D[15:0]	D[15:0]	I/O*	D[15:0]	I/O	Data Bus , D0 is the LSB of data
A[9:1]	A[9:1]	O	A[9:1]	I	Address Bus , A1 is the LSB of address
RD/WR#	RD/WR#	O	WE#	I	Read/Write – Indicates the direction of the data transfer for a transaction. A logic one indicates a read from a slave device; a logic zero indicates a write to a slave device.
OE#	OE#	O	OE#	I	Output Enable Signal , controls AMI data output during read transactions
IRQn#	IRQn#	I	INT_CC#	O	Interrupt Request (level sensitive) – One of the eight external lines that can request, by means of the internal interrupt controller, a service routine from the MPC555.
IF_SEL[0:1]	–	–	IF_SEL[0:1]	I	Interface Select – FlexRay CC MCU interface configuration pins
CSn#	CSn#	O	CE#	I	Chip Select/Chip Enable – These signal enable peripheral or memory devices at programmed addresses if defined appropriately in the memory controller.

Where:

I – input pin; O – output pin; I/O – input/output pin

3.7.2 MFR4200 HCS12 Interface

The MFR4200 HCS12 interface with HCS12 EBI paged mode support is shown in [Figure 3-145](#).

The FlexRay CC to HCS12 connection with HCS12 EBI unpagged mode support is shown in [Figure 3-146](#).

- The MFR4200 HCS12 interface supports the paged and unpagged modes of the HCS12 external bus interface connected to it.
- The MFR4200 HCS12 interface is implemented as a synchronous HCS12 external bus slave module, thus enabling fast data exchange between them.
- The MFR4200 HCS12 interface decodes addresses of read/write transactions to its internal registers and generates its internal CS signal with the use of the address/data lines PAD[0:15], ACS[0:5] and XADDR[14:19] (see [Figure 3-147](#)).
 - The address and data lines PAD[0:15] are multiplexed. They are denoted ADR[0:15] when referring to the address and DATA[0:15] when referring to the data. The MFR4200 is selected only when the address ADR[10:15] matches ACS[0:5] (ADR[10] matches ACS[0], ADR[11] matches ACS[1], etc.), and the address XADDR[14:19] matches 0.

- The HCS12 interface module accepts only aligned 16-bit wide read/write and 8-bit wide read transactions. The FlexRay CC module does not support 8-bit wide write accesses. The error indication bit ILLADR (illegal address) is raised in the CHIER (see [Section 3.2.3.6.3, “CHI Error Register \(CHIER\)”](#)) in the event of an 8 bit write transaction, or if an unaligned half word transaction is performed (detected if ADDR[0] is equal to 1 or if LSTRB is equal to 1). Data 0x0000 is presented to the host in this case.
- the RW_CC# signal indicates the direction of data transfer for a transaction.
- INT_CC# is an interrupt line that can be used for requesting, by means of the internal interrupt controller, a service routine from the HCS12 device.

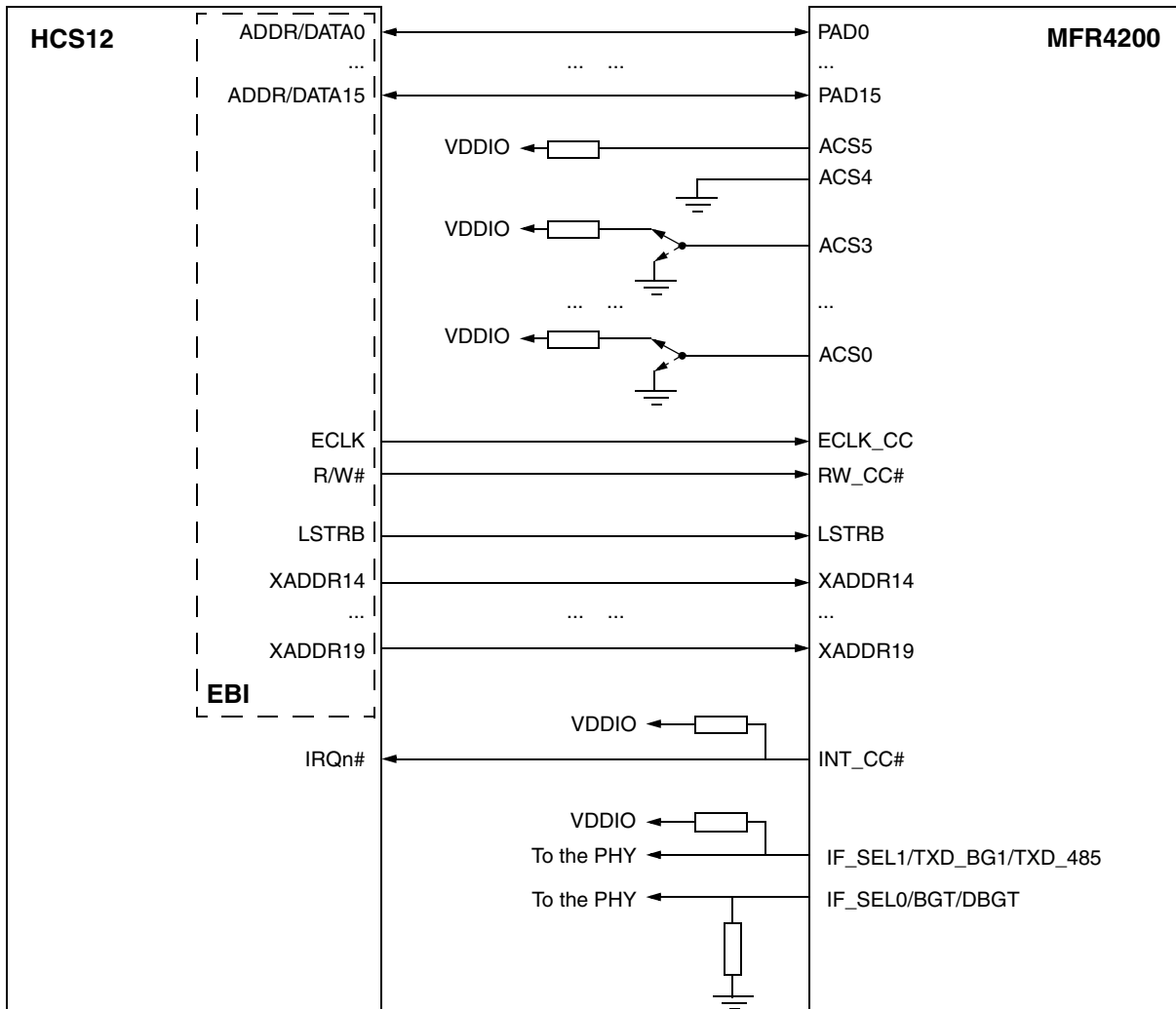

Figure 3-145. FlexRay CC to HCS12 Device Connection with HCS12 EBI Paged Mode Support

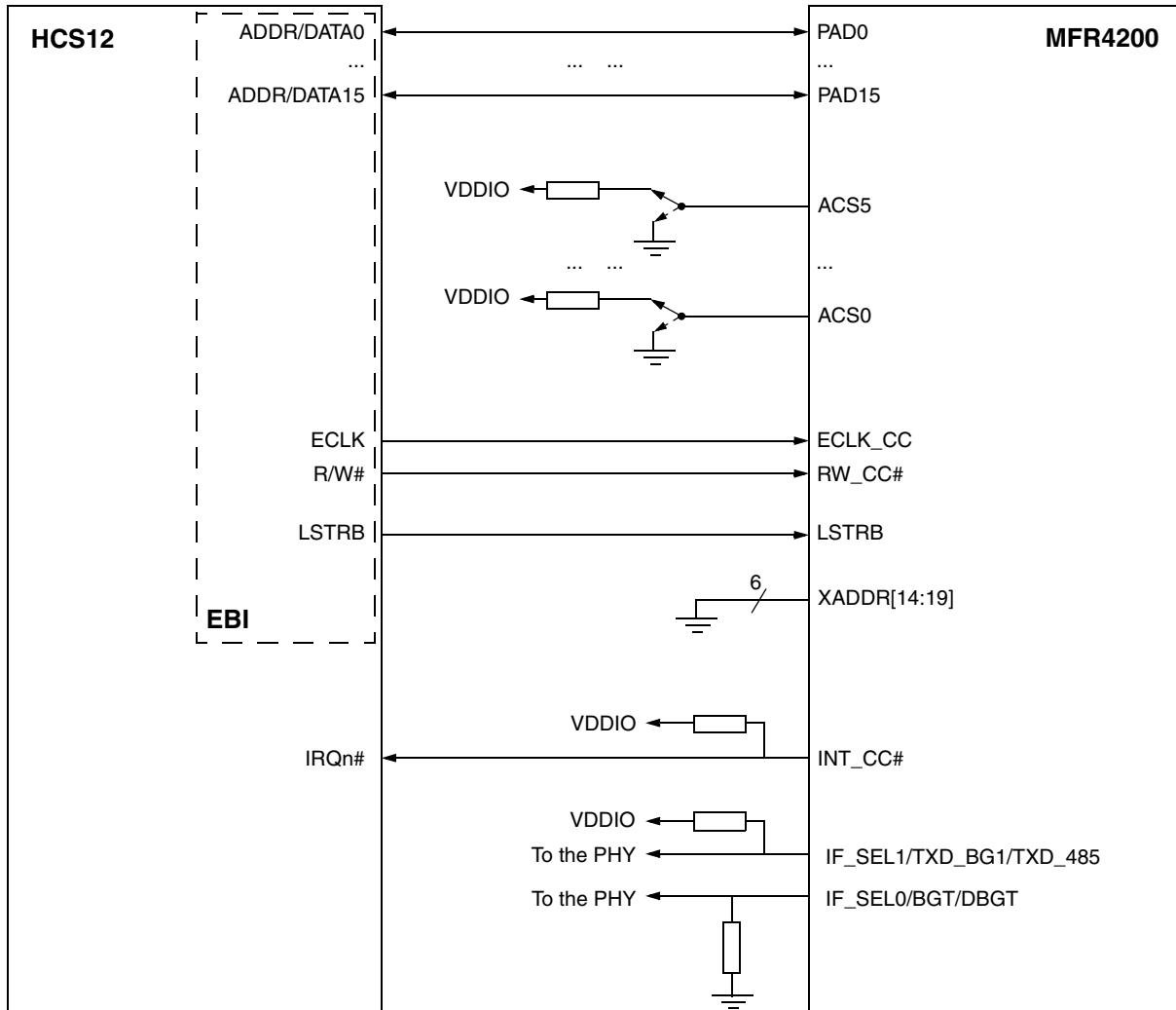

Figure 3-146. FlexRay CC to HCS12 Device Connection with HCS12 EBI Unpaged Mode Support

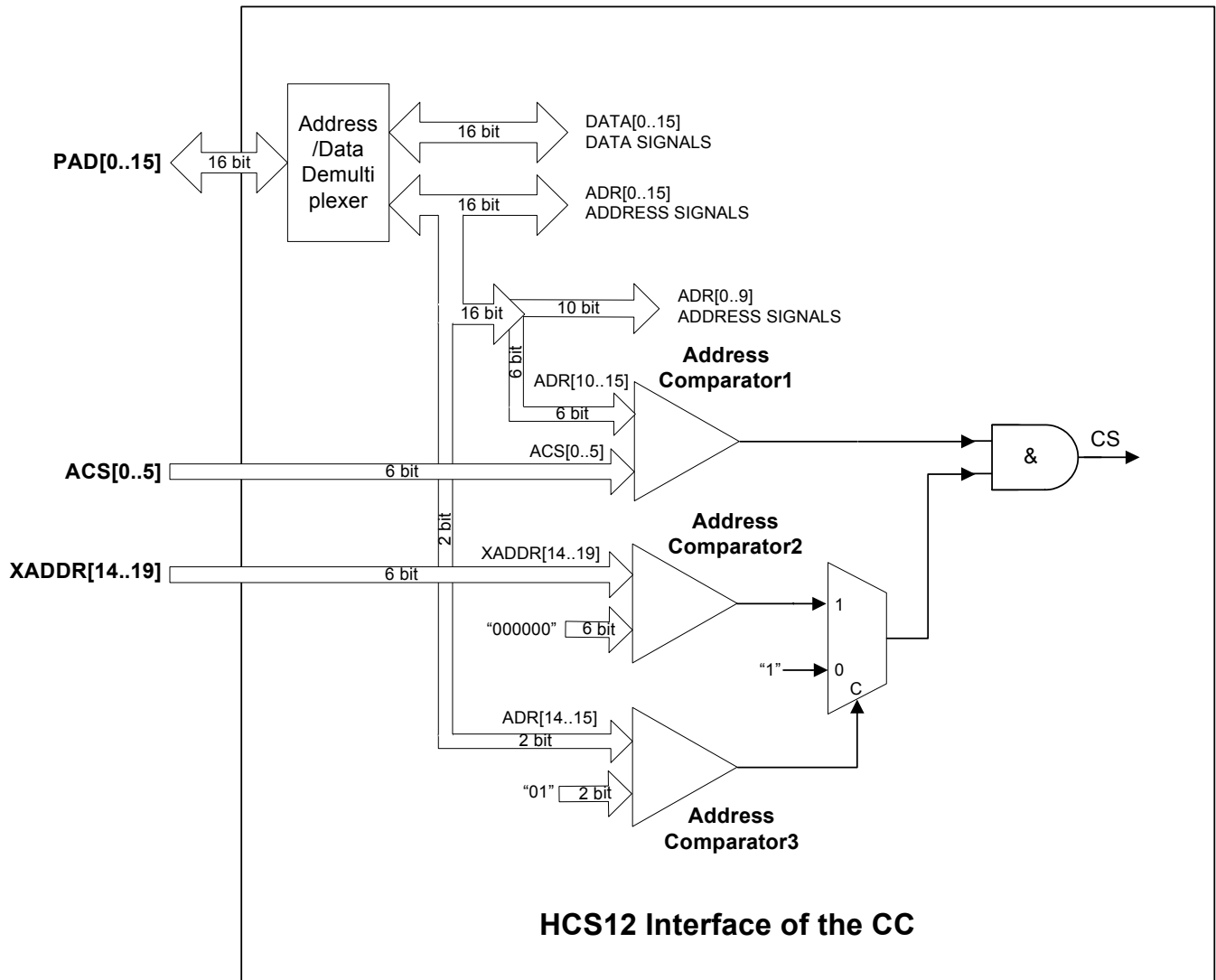

Figure 3-147. HCS12 interface Address Decoding and Internal CS Signal Generation

3.7.2.1 HCS12 Interface Signal and Pin Descriptions

Table 3-21. HCS12 Interface Signal and Pin Descriptions

Signal name	HCS12 External Bus		FlexRay CC MCU Interface Pin		Function Description
	Name	I/O	Name	I/O ¹	
AD[0:15]	ADDR/DATA[0:15]	I/O*	PAD[0:15]	I/O	Multiplexed external address data bus (AD0 is the LSB; AD15 is the MSB)
ECLK#	ECLK#	O	ECLK_CC#	I	Internal bus clock output – This output line is the clock system frequency of the HCS12
XADDR[14:19]	XADDR[14:19]	O	XADDR[14:19]	I	HCS12 interface expanded address lines – (XADDR14 is the LSB of the HCS12 interface expanded address lines)
ACS[0:5]	–	–	ACS[0:5]	I	HCS12 interface, address select inputs. ACS5: MSB of the address select inputs
RD/WR#	RD/WR#	O	RW_CC#	I	Read/Write – Indicates the direction of the data transfer for a transaction. A logic one indicates a read from a slave device; a logic zero indicates a write to a slave device.
LSTRB#	LSTRB#	O	LSTRB#	I	Low-byte Strobe – indicates the type of bus access
IRQ#	IRQ#	I	INT_CC#	O	Interrupt Request (level sensitive) – One of the external lines that can request, by means of the internal interrupt controller, a service routine from the HCS12.
IF_SEL[0:1]	–	–	IF_SEL[0:1]	I	Interface Select – FlexRay CC MCU interface configuration pins

¹ I – input pin; O – output pin; I/O – input/output pin

3.8 External 4/10 MHz Output Clock

A continuous external 4/10 MHz output clock signal is provided by the CC on the CLKOUT pin. This signal is always active after power-up of the CC in all CC states including the hard reset state. The CLKOUT signal is disabled during the internal power-on and low voltage reset procedures (refer to [Chapter 5, “Clocks and Reset Generator”](#) for more information).

The output frequency of the CLKOUT signal is selected by the CLK_S0, CLK_S1 input pins, in accordance with [Table 3-22](#).

Table 3-22. CLKOUT Frequency Selection

Pin		CLKOUT Function
CLK_S0	CLK_S1	
0	0	4 MHz output
1	0	10 MHz output
0	1	40 MHz output
1	1	Disabled (CLKOUT output is “0”)

NOTE

For information on CLKOUT stabilization timing parameters, refer to [Appendix A, “Electrical Characteristics”](#).

3.9 Communication Controller States

3.9.1 Hard Reset State

Protocol Operation Control: Initiate hardware state.

During this state, the CC initializes all internal registers to their specified hard reset default state (see [Section 3.2.2, “Register Map Summary”](#)).

In the hard reset state:

- All the operation with protocol state machine are stopped.
- There is no transmission or reception on the FlexRay bus.
- There is no clock synchronization running.
- The CC host interface is stopped.
- The CC analyzes the input signals on the two pins IF_SEL0 and IF_SEL1 while leaving the hard reset state to configure the interface for the type of MCU (see [Section 3.7, “Host Controller Interfaces”](#)).

The CC enters the hard reset state:

- According to the state of the hard reset pin (see [Section 5.2.2, “Reset Generation and CLKOUT Control”](#)).

NOTE

In the hard reset state, the host MCU type is not defined. If the host accesses the CC during this state, the CC can enter into an unpredictable state. Therefore, the host is prohibited from performing any accesses to the CC when the CC is in the hard reset state.

Initialization of the CC is done on leaving the hard reset state, i.e. on a rising edge of the hard reset signal (see [Section 3.2.3.1.3, “Magic Number Register \(MNR\)”](#)). After leaving the hard reset state, the host must wait until initialization is complete, before reading or writing to the controller.

During this internal initialization procedure, the CC initializes its internal memory including following configuration/control parameters of its message buffers.

- Frame ID = 0x0
- CCFnR: Cycle Count Mask and Cycle Counter Value fields = 0
- BUFCSnR:
 - BUFCMT = 0
 - ChA, ChB = 0
 - BT = 0
 - CCFE = 0
 - TT = 0
 - LOCK = 0
 - IFLG = 0
 - VALID = 0
 - IENA = 0
 - CFG = 0
 - DATAUPD = 0

During the internal initialization procedure the host must not access any of the CC registers except MNR (see [Section 3.2.3.1.3, “Magic Number Register \(MNR\)”](#)), which acknowledges the end of the internal initialization procedure.

The CC exits the hard reset state and enters the configuration state, after the hard reset signal is negated (see [Section 3.2.3.2.1, “Module Configuration Register 0 \(MCR0\)”](#)).

3.9.2 Configuration State

Protocol Operation Control: Config state.

During this state, the host configures the CC in accordance with the access scheme for CC internal resources (see [Section 3.2.3.2.1](#), “Receive, receive FIFO, and transmit message buffers are accessible to the host MCU only through the active receive, active transmit, and active receive FIFO buffers.”) and the configuration principles (see [Section 3.5](#), “Message Buffer Handling and Operations”).

In the configuration state:

- All operations with the protocol state machine are stopped.
- There is no transmission or reception on the FlexRay bus.
- There is no clock synchronization running.
- The host interface of the CC is operational.
- The host type is fixed after the hard reset state.
- All message buffers, after entering the configuration state from the hard reset state, are “not used” buffers. The CC stores its configuration if it enters the configuration state from a state other than the hard reset state.
- If the host puts the CC into the configuration state by setting the CONFIG bit in MCR0 register to ‘1’ (see [Section 3.2.3.2.1](#), “Module Configuration Register 0 (MCR0)”), the CC configuration data will be held, except data that is initialized when leaving the configuration state.

On leaving the configuration state, some registers are cleared by the CC (this operation is highlighted in descriptions of those registers).

The CC enters the configuration state:

- By leaving the hard reset state.
- According to the state of the CONFIG bit in the MCR0 register (see [Section 3.2.3.2.1](#), “Module Configuration Register 0 (MCR0)”).
- By leaving the sleep state or the diagnosis stop states.

NOTE

The CC enters the configuration state immediately the MCR0 CONFIG bit is set. This may cause a protocol violation; the user must take care to ensure that entry to the configuration state does not cause a protocol violation.

The CC exits from the configuration state and enters the normal state of operation (see [Section 3.9.4](#), “Normal Active State”).

[Figure 3-148](#) represents a timing diagram of the transition from the configuration state to the normal state.

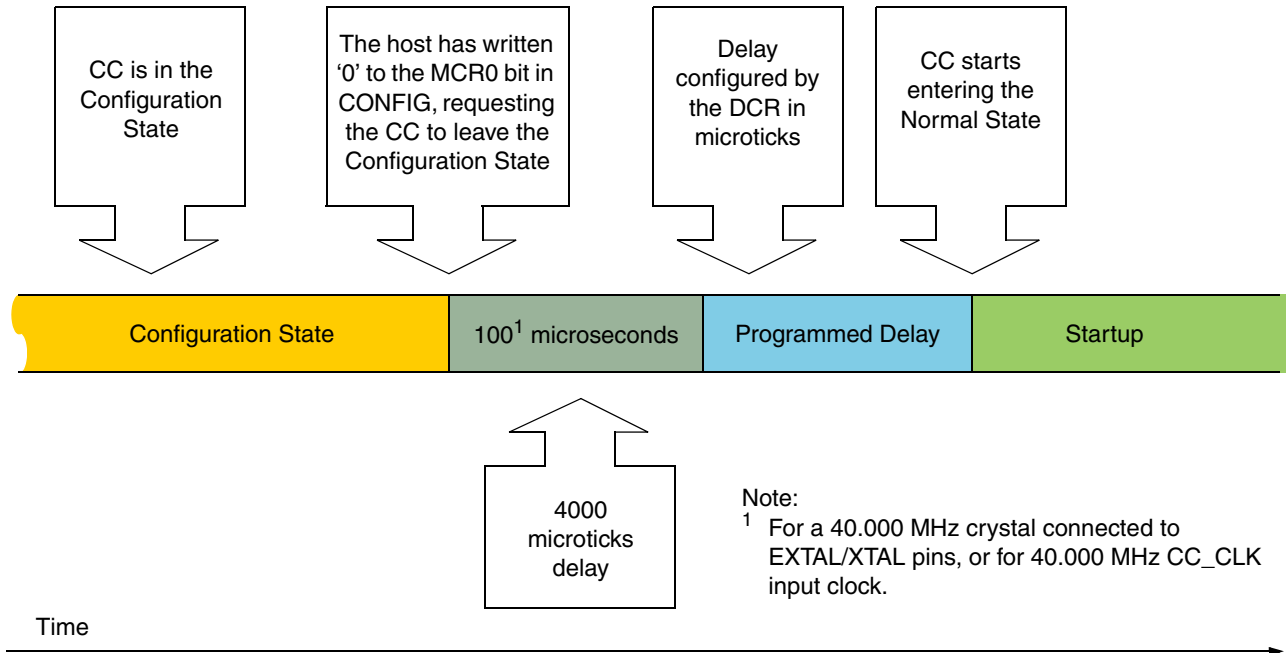

Figure 3-148. Timing Diagram of CC State Transition from Configuration State to Normal State

3.9.3 Diagnosis Stop State

Protocol Operation Control: Freeze state.

The diagnosis stop state is intended to support the user during host software off-line system diagnosis. It allows:

- the user to stop all protocol engine operations (frame transmission, reception, clock synchronization, etc.) except host interface operations,
- the host to read all host interface registers.

In the diagnosis stop state:

- All operations of the protocol state machine are stopped.
- There is no transmission and no reception on the FlexRay bus.
- There is no clock synchronization running.
- The host interface is operational.
- All registers have the same access scheme as they have in normal operation (see [Table 3-16](#));

The CC enters the diagnosis stop state from the normal state of operation:

- If the host sets the DIAGSTOP bit in the MCR0 register (see [Section 3.2.3.2.1, “Module Configuration Register 0 \(MCR0\)”](#)).

NOTE

The CC enters the diagnosis stop state immediately the DIAGSTOP bit is set. This may cause a protocol violation; the user must ensure that entry to the diagnosis stop state does not cause a protocol violation.

The CC exits from the diagnosis stop state and enters the configuration state (see [Section 3.9.2, “Configuration State”](#)).

3.9.4 Normal Active State

Protocol Operation Control: Normal active state.

In the normal state, the CC supports regular communication functions — frame transmission, reception, clock synchronization, host interface operations, etc.

In the normal state:

- The CC performs transmission and reception on the FlexRay bus, if configured.
- Clock synchronization runs.
- The host interface is operational.
- All registers comply with the access scheme shown in [Table 3-16](#).

The CC enters the normal state from the configuration state:

- If the host clears the CONFIG bit in the MCR0 register to ‘0’ (see [Section 3.2.3.2.1, “Module Configuration Register 0 \(MCR0\)”](#)).

The CC exits the normal state and enters:

- The configuration state, according to the state of the CONFIG bit in the MCR0 register
- The diagnosis stop state, according to the state of the DIAGSTOP bit in the MCR0 register.
- The debug state, according to the state of the DBG bit in the MCR0 register.
- The listen only state, according to the state of the LO bit in the MCR0 register.
- The listen only state, to deal with errors caused by clock synchronization failure (for more detailed information, refer to the PWD: Clock Synchronization chapter).
- The sleep state, according to the state of the SLPRQ and SLPACK bits in the MCR0 register.

For the description of the SLPRQ, SLPACK, CONFIG, DIAGSTOP, DBG and LO bits, see [Section 3.2.3.2.1, “Module Configuration Register 0 \(MCR0\)”](#).

NOTE

For a detailed description of the normal state, refer to the PWD: HW States and Operation Modes chapter.

3.9.5 Normal Passive State

Protocol Operation Control: Normal passive state.

In the normal passive state, the CC supports regular communication functions (reception, clock synchronization, host interface operations, etc.), except frame transmission.

In the normal passive state:

- The CC receives frames on the FlexRay bus, if configured.
- The CC does not transmit any frames on the FlexRay bus.
- Clock synchronization runs.
- The host interface is operational.
- All registers comply with the access scheme shown in [Table 3-16](#).

The CC enters the normal passive state from the normal mode of operation:

- From the normal active state, if the clock synchronization failed (for more detailed information, refer to the PWD: Clock Synchronization chapter)

NOTE

The CC enters the normal passive state at the end of the current communication cycle.

The CC exits the normal passive state and enters:

- The configuration state, according to the state of the CONFIG bit in the MCR0 register;
- The diagnosis stop state, according to the state of the DIAGSTOP bit in the MCR0 register;
- The debug state, according to the state of the DBG bit in the MCR0 register;
- The sleep state, according to the state of the SLPRQ and SLPACK bits in the MCR0 register; (see [Section 3.2.3.2.1, “Module Configuration Register 0 \(MCR0\)”](#)).

NOTE

For a detailed description of the listen state, refer to the PWD: HW States and Operation Modes chapter.

3.10 Debug Port

3.10.1 Debug Port Overview

The debug port is provided by means of two MFR4200 pins — BGT/DBG2/IF_SEL0 and ARM/DBG1/CLK_S0. The debug port control register (see [Section 3.2.3.3.33, “Debug Port Control Register \(DBPCR\)”](#)) selects the output functions for these two pins. The functions are controlled independently of each other and, therefore, the same or different output functions may be configured for the BGT/DBG2/IF_SEL0 and ARM/DBG1/CLK_S0 pins.

NOTE

As the DBG1 and DBG2 signals are shared with the bus guardian output signals on the BGT/DBG2/IF_SEL0 and ARM/DBG1/CLK pins, the debug port pins are not accessible in applications where bus guardian devices are connected to the MFR4200.

3.10.2 Debug Port Functions

Table 3-23 describes all debug port functions.

Table 3-23. Debug Port Functions Description

Function	Short Name	Indicated by	Description
Protocol state change	PCS	Rising edge of the signal	The CC strobes every protocol state change (see Section 3.2.3.4.1, "Protocol State Register (PSR)").
Slot start in static segment	SSS	Rising edge of the signal	The CC strobes every static slot start.
Minislot start	MSS	Rising edge of the signal	The CC strobes every minislot start.
RxD after glitch filter on channel A	RAGFA	—	This function outputs data received on channel A RxD (RXD_BG1/RXD1_485 pin) after glitch filter processing.
Dynamic slot start on channel A	DSSA	Rising edge of the signal	The CC strobes every dynamic slot start on channel A.
Start of frame on channel A	SFA	Rising edge of the signal	The CC strobes every receive frame start on channel A.
Received syntactically correct an semantically valid frame indication on channel A	RCFA	Rising edge of the signal	The CC indicates every reception of a syntactically correct and semantically valid frame on channel A after 11 FlexRay bus bits, measured from the received frame end sequence.
Start of a communication cycle	SCC	Rising edge of the signal and its level	The CC strobes every communication cycle start with a rising edge. This signal stays high during the communication cycle and the CC negates it (low) with the NIT start.
Macrotick	MTS	Rising edge of the signal	This function outputs the CC internal corrected macrotick.
Start of offset correction	SOC	Rising edge of the signal	The CC strobes the time point during the NIT when it performs the offset correction.
RxD after glitch filter on channel B	RAGFB	—	This function outputs data received on channel B RxD (RXD_BG2/RXD2_485 pin) after glitch filter processing.
Dynamic slot start on channel B	DSSB	Rising edge of the signal	The CC strobes every dynamic slot start on channel B.
Start of frame on channel B	SFB	Rising edge of the signal	The CC strobes every receive frame start on channel B.
Received syntactically correct an semantically valid frame indication on channel B	RCFB	Rising edge of the signal	The CC indicates every reception of a syntactically correct and semantically valid frame on channel B after 11 FlexRay bus bits measured from the received frame end sequence.

3.10.3 Debug Port Function Timing

Figure 3-149 depicts a timing diagram for the start of communication cycle function and the start of offset correction function, in relation to the communication cycle timing.

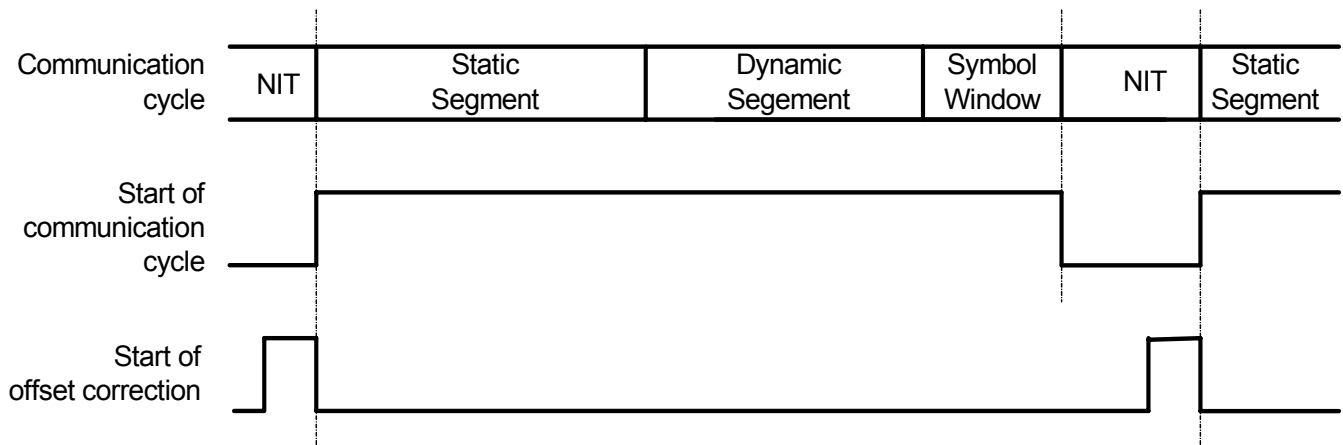

Figure 3-149. Start of Communication Cycle and Start of Offset Correction Functions Timing

The following debug functions indicate certain events with the rising edge and stay high for three clock cycles of the EXTAL or CC_CLK clock (see Figure 3-150).

- Protocol state change
- Minislot start
- RxD after glitch filter on channel A
- Dynamic slot start on channel A
- Start of frame on channel A
- Indication of syntactically correct and semantically valid frame received on channel A
- Macrotick
- RxD after glitch filter on channel B
- Dynamic slot start on channel B
- Start of frame on channel B
- Indication of syntactically correct and semantically valid frame received on channel B

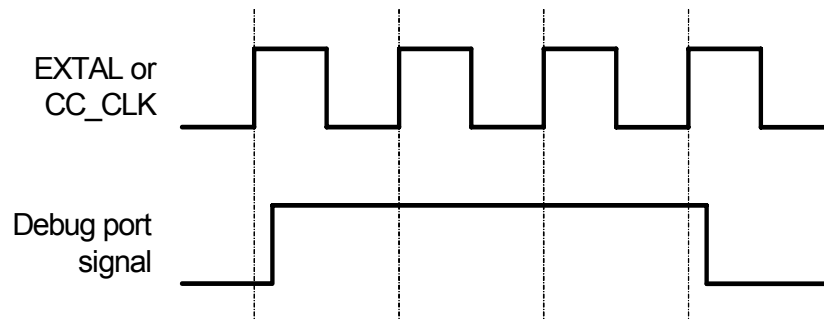

Figure 3-150. Timing for Debug Functions with Three EXTAL or CC_CLK Clock Cycles of High State (Logic "1")

The slot start in static segment debug function indicates every slot start event in the static segment with a rising edge that stays high for one clock cycle of the EXTAL or CC_CLK clock (see [Figure 3-151](#)):

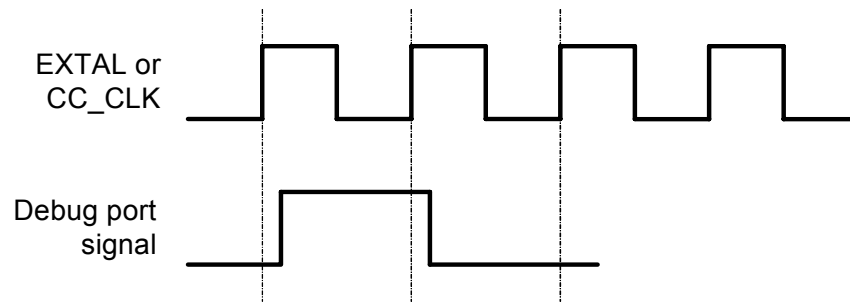

Figure 3-151. Slot Start in Static Segment Function Timing

Chapter 4

Dual Output Voltage Regulator (VREG3V3V2)

4.1 Introduction

The VREG3V3V2 is a dual output voltage regulator providing two separate 2.5 V (typical) supplies differing in the amount of current that can be sourced. The regulator input voltage range is from 3.3 V up to 5 V (typical).

4.1.1 Features

The block VREG3V3V2 includes these distinctive features:

- Two parallel, linear voltage regulators
 - Bandgap reference
- Power-on reset (POR)
- Low-voltage reset (LVR)

4.1.2 Modes of Operation

VREG3V3V2 can operate in two modes on MFR4200:

- Full-performance mode (FPM)

The regulator is active, providing the nominal supply voltage of 2.5 V with full current sourcing capability at both outputs. Features LVR (low-voltage reset) and POR (power-on reset) are available.
- Shutdown mode

Controlled by V_{REGEN} (see device overview chapter for connectivity of V_{REGEN}).

This mode is characterized by minimum power consumption. The regulator outputs are in a high impedance state; only the POR feature is available, and LVR is disabled.

This mode must be used to disable the chip internal regulator VREG3V3V2, i.e., to bypass the VREG3V3V2 to use external supplies.

4.1.3 Block Diagram

Figure 4-1 shows the function principle of VREG3V3V2 by means of a block diagram. The regulator core REG consists of two parallel sub-blocks, REG1 and REG2, providing two independent output voltages.

Dual Output Voltage Regulator (VREG3V3V2)

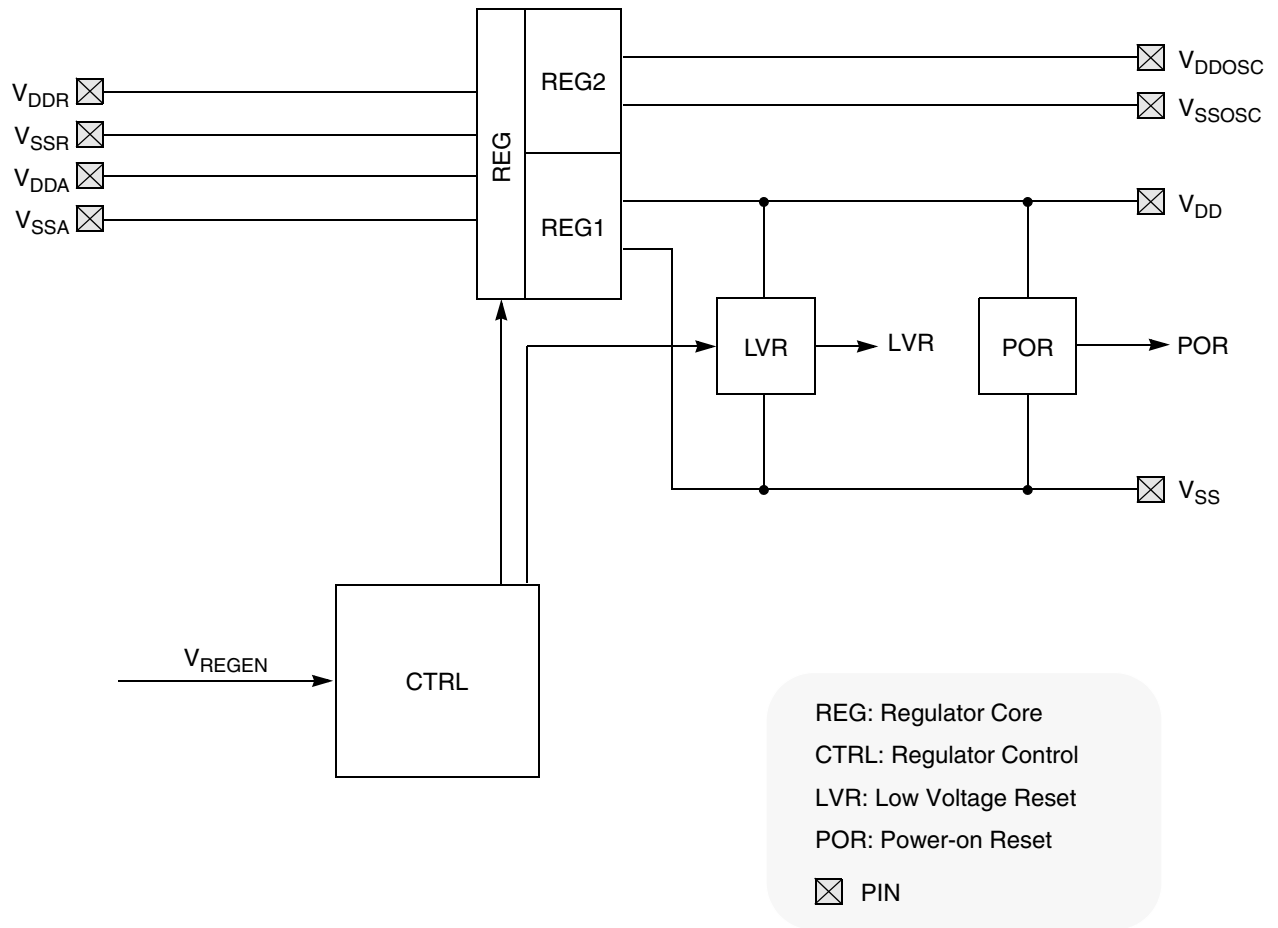

Figure 4-1. VREG3V3 Block Diagram

4.2 External Signal Description

Due to the nature of VREG3V3V2 being a voltage regulator providing the chip internal power supply voltages most signals are power supply signals connected to pads.

Table 4-1 shows all signals of VREG3V3V2 associated with pins.

Table 4-1. VREG3V3V2 — Signal Properties

Name	Port	Function	Reset State	Pull Up
V_{DDR}	—	VREG3V3V2 power input (positive supply)	—	—
V_{SSR}	—	VREG3V3V2 power input (ground)	—	—
V_{DDA}	—	VREG3V3V2 quiet input (positive supply)	—	—
V_{SSA}	—	VREG3V3V2 quiet input (ground)	—	—
V_{DD}	—	VREG3V3V2 primary output (positive supply)	—	—
V_{SS}	—	VREG3V3V2 primary output (ground)	—	—
V_{DDOSC}	—	VREG3V3V2 secondary output (positive supply)	—	—
V_{SSOSC}	—	VREG3V3V2 secondary output (ground)	—	—
V_{REGEN} (optional)	—	VREG3V3V2 (Optional) Regulator Enable	—	—

NOTE

Check device overview chapter for connectivity of the signals.

4.2.1 V_{DDR} , V_{SSR} — Regulator Power Input

Signal V_{DDR} is the power input of VREG3V3V2. All currents sourced into the regulator loads flow through this pin. A chip external decoupling capacitor (100 nF...220 nF, X7R ceramic) between V_{DDR} and V_{SSR} can smoothen ripple on V_{DDR} .

For entering shutdown mode, pin V_{DDR} must also be tied to ground on devices without a V_{REGEN} pin.

4.2.2 V_{DDA} , V_{SSA} — Regulator Reference Supply

Signals V_{DDA}/V_{SSA} which are supposed to be relatively quiet are used to supply the analog parts of the regulator. Internal precision reference circuits are supplied from these signals. A chip external decoupling capacitor (100 nF...220 nF, X7R ceramic) between V_{DDA} and V_{SSA} can further improve the quality of this supply.

4.2.3 V_{DD} , V_{SS} — Regulator Output1 (Core Logic)

Signals V_{DD}/V_{SS} are the primary outputs of VREG3V3V2 that provide the power supply for the core logic. These signals are connected to device pins to allow external decoupling capacitors (100 nF...220 nF, X7R ceramic).

In shutdown mode an external supply at V_{DD}/V_{SS} can replace the voltage regulator.

4.2.4 V_{DDOSC} , V_{SSOSC} — Regulator Output2 (OSC)

Signals V_{DDOSC}/V_{SSOSC} are the secondary outputs of VREG3V3V2 that provide the power supply for the oscillator. These signals are connected to device pins to allow external decoupling capacitors (100 nF...220 nF, X7R ceramic).

In shutdown mode an external supply at V_{DDOSC}/V_{SSOSC} can replace the voltage regulator.

4.2.5 V_{REGEN} — Optional Regulator Enable

This optional signal is used to shutdown VREG3V3V2. In that case V_{DD}/V_{SS} and V_{DDOSC}/V_{SSOSC} must be provided externally. shutdown mode is entered with V_{REGEN} being low. If V_{REGEN} is high, the VREG3V3V2 is in reduced-power mode.

For the connectivity of V_{REGEN} see device overview chapter.

NOTE

Switching from FPM or RPM to shutdown of VREG3V3V2 and vice versa is not supported while the CC is powered.

4.3 Functional Description

Block VREG3V3V2 is a voltage regulator as depicted in [Figure 4-1](#). The regulator functional elements are the regulator core (REG), a power-on reset module (POR) and a low-voltage reset module (LVR). There is also the regulator control block (CTRL) which manages the operating modes of VREG3V3V2.

4.3.1 REG — Regulator Core

VREG3V3V2, respectively its regulator core has two parallel, independent regulation loops (REG1 and REG2) that differ only in the amount of current that can be sourced to the connected loads. Therefore, only REG1 providing the supply at V_{DD}/V_{SS} is explained. The principle is also valid for REG2.

The regulator is a linear series regulator with a bandgap reference in its full-performance mode and a voltage clamp in reduced-power mode. All load currents flow from input V_{DDR} to V_{SS} or V_{SSOSC} , the reference circuits are connected to V_{DDA} and V_{SSA} .

4.3.2 Full-performance Mode

In full-performance mode, a fraction of the output voltage (V_{DD}) and the bandgap reference voltage are fed to an operational amplifier. The amplified input voltage difference controls the gate of an output driver.

4.3.3 POR — Power On Reset

This functional block monitors output V_{DD} . If V_{DD} is below $V_{POR\overline{D}}$, signal POR is high; if it exceeds $V_{POR\overline{D}}$, the signal goes low. The transition to low forces the CPU into the power-on sequence.

Due to its role during chip power-up, this module must be active in all operating modes of VREG3V3V2.

4.3.4 LVR — Low Voltage Reset

Block LVR monitors the primary output voltage V_{DD} . If it drops below the assertion level (V_{LVRA}) signal LVR asserts and when rising above the deassertion level ($V_{LVR\overline{D}}$) signal LVR negates again. The LVR function is available only in full-performance mode.

4.3.5 CTRL — Regulator Control

This part contains digital functionality needed to control the operating modes.

4.4 Resets

This subsection describes how VREG3V3V2 controls the reset of the CC. The reset values of registers and signals are provided in [Section 3.2, “Memory Map and Registers”](#). Possible reset sources are listed in [Table 4-2](#).

Table 4-2. VREG3V3V2 — Reset Sources

Reset Source	Local Enable
Power-on reset	Always active
Low-voltage reset	Always active

4.4.1 Power On Reset

During chip power-up the digital core may not work if its supply voltage V_{DD} is below the POR deassertion level ($V_{POR\overline{D}}$). Therefore, signal POR, which forces the other blocks of the device into reset, is kept high until V_{DD} exceeds $V_{POR\overline{D}}$. Then POR becomes low and the reset generator of the device continues the start-up sequence.

4.4.2 Low Voltage Reset

For information on low-voltage reset see [Section 4.3.4, “LVR — Low Voltage Reset”](#).

Chapter 5

Clocks and Reset Generator

5.1 Introduction

This document describes the CRG operation in functional mode and only those aspects of it useful to the end user.

5.1.1 Features

The main features of this block are:

- System clock generator depending on the mode: functional, scan or memory BIST mode.
- System reset generation from the following possible events:
 - Power-on
 - Low voltage
 - External pin reset
- Reset control signal generation for the FlexRay module's CLKOUT generator.

5.2 Functional Description

5.2.1 MFR4200 Pins Relevant to the CRG

Table 5-1. MFR4200 Pins Relevant to the CRG

Pin N	Pin Name	In/Out	Pin type ¹	Functional Description
1	TEST	I	-	This pin must be tied to logic '0'.
16	RESET#	I	-	Hardware reset input
24	EXTAL/CC_CLK	I	-	Crystal driver / External clock pin
25	XTAL	I	-	Crystal driver pin
32	BGT/DBG2/IF_SEL0	I/O	DC/PD	Bus guardian tick / Debug strobe point signal 2 / Host interface selection 0
41	TXD_BG1/TXD1_485/ IF_SEL1	I/O	DC/PD	PHY data transmitter output / RS485 data transmitter output / Host interface selection 1
47	ARM/DBG1/CLK_S0	I/O	DC/PD	Bus guardian ARM signal / Debug strobe point signal 1 / Controller clock output select signal 0
48	MT/CLK_S1	I/O	DC/PD	Bus guardian macrotick / Controller clock output select signal 1
52	ECLK_CC	I	PC	HCS12 clock input
63	CLKOUT	I/O	DC	CLKOUT output, selectable as disabled or 4/10/40 MHz.

¹ PC (Pullup/down Controlled) – Register controlled internal weak pull up/down for a pin in the input mode.

PD (Pull Down) – Internal weak pull down for a pin in the input mode.

DC (Drive strength Controlled) – Register controlled drive strength for a pin in the output mode.

Z – Three-stated pin.

OD (Open Drain) – Output pin with open drain.

Reset state:

- All pins with the PC option have pullup/down resistors disabled.
- All pins with the DC option have full drive strength.

5.2.2 Reset Generation and CLKOUT Control

The CRG will provide a system reset on any of the following events: power-on, low voltage, or low level detected at the RESET# pin. Entry into reset is asynchronous and does not require a clock; however, the MFR4200 cannot sequence out of reset in functional mode without a system clock.

The CRG scans, during different periods depending on the origin of the reset source, the interface and CLKOUT selector pins: IF_SEL[0:1] and CLK_S[0:1].

NOTE

See [Section 3.7, “Host Controller Interfaces”](#) and [Section 3.8, “External 4/10 MHz Output Clock”](#) for a description of the encoding of these pins.

5.2.2.1 Power-on or Low Voltage Reset

When the power-on or low voltage reset signals are asserted, the CRG sets the internal reset signal. The CRG will negate synchronously the internal reset signal, approximately 16000 EXTAL/CC_CLK clock ticks after the negation of the power-on or low-voltage reset signals.

While the internal reset signal is asserted due to a power-on or low-voltage situation, the pins CLK_S[0:1] and IF_SEL[0:1] are latched and the CLKOUT is disabled. After the CRG negates the internal reset signal the FlexRay core will:

1. generate CLKOUT signal with frequency indicated by the values latched in CLK_S[0:1],
2. select the required host interface with the last value latched in IF_SEL[0:1] signals.

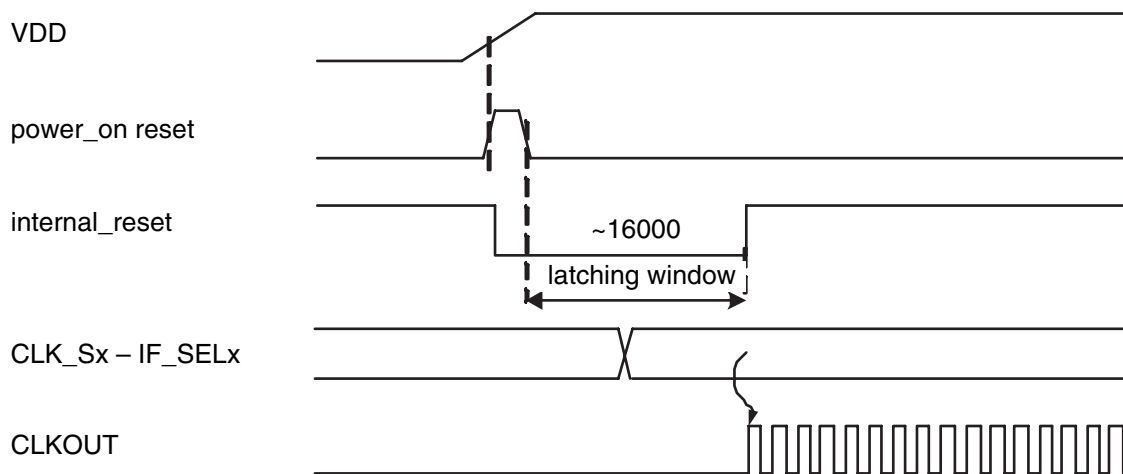
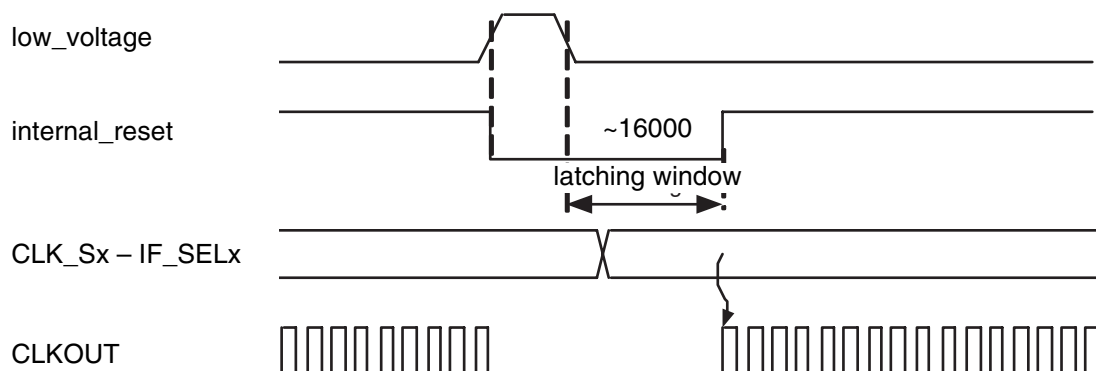

Figure 5-1. Power-on Reset



low_level_voltage

Figure 5-2. Low Voltage Reset

5.2.2.2 External Reset

When the RESET# pin is asserted the CRG sets the internal reset signal. The CRG will negate the internal reset signal approximately 16 EXTAL/CC_CLK clock ticks after the de-assertion of RESET#.

While the internal reset signal is asserted due to an external reset, the pins CLK_S[0:1] and IF_SEL[0:1] are latched but the CLKOUT signal is still be generated. [Figure 5-3](#) shows an external reset sequence.

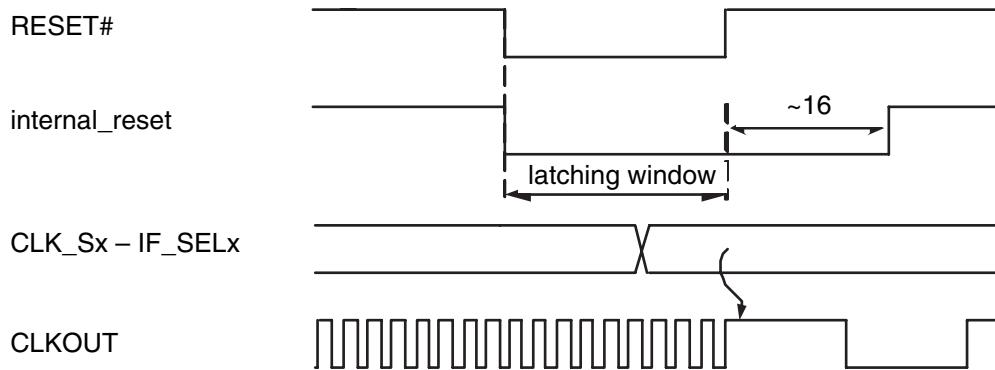

Figure 5-3. External Reset

Chapter 6

Oscillator (OSCV2)

6.1 Introduction

The OSCV2 module provides one oscillator concept:

- A robust full swing Pierce oscillator with the possibility to feed in an external square wave

6.1.1 Features

The Pierce OSC option provides the following features:

- Wider high frequency operation range
- No DC voltage applied across the crystal
- Full rail-to-rail (2.5 V nominal) swing oscillation with low EM susceptibility
- Fast startup

Common features:

- Operation from the V_{DDOSC} 2.5 V (nominal) supply rail

6.1.2 Modes of Operation

One mode of operation exists:

- Full swing Pierce oscillator mode, which can also be used to feed in an externally generated square wave suitable for high frequency operation and harsh environments

6.2 External Signal Description

This section lists and describes the signals that connect off chip.

6.2.1 V_{DDOSC} and V_{SSOSC} — OSC Operating Voltage, OSC Ground

These pins provide the operating voltage (V_{DDOSC}) and ground (V_{SSOSC}) for the OSCV2 circuitry. This allows the supply voltage to the OSCV2 to be independently bypassed.

6.2.2 EXTAL and XTAL — Clock/Crystal Source Pins

These pins provide the interface for either a crystal or a CMOS compatible clock to control the internal clock generator circuitry. EXTAL is the external clock input or the input to the crystal oscillator amplifier. XTAL is the output of the crystal oscillator amplifier. All the CC internal system clocks are derived from

the EXTAL input frequency. In full stop mode (PSTP = 0) the EXTAL pin is pulled down by an internal resistor of typical 200 k Ω .

NOTE

Freescale Semiconductor recommends an evaluation of the application board and chosen resonator or crystal by the resonator or crystal supplier.

The Crystal circuit is changed from standard.

The Pierce circuit is not suited for overtone resonators and crystals without a careful component selection.

For more information on EXTAL and XTAL, see [Section 2.2.3.22, “XTAL — Crystal Driver Pin”](#).

6.3 Functional Description

The OSCV2 block has two external pins, EXTAL and XTAL. The oscillator input pin, EXTAL, is intended to be connected to either a crystal or an external clock source.

A buffered EXTAL signal, OSCCLK, becomes the internal reference clock. To improve noise immunity, the oscillator is powered by the V_{DDOSC} and V_{SSOSC} power supply pins.

Appendix A

Electrical Characteristics

A.1 General

NOTE

The electrical characteristics given in this appendix are preliminary and must be used as a guide only. Values cannot be guaranteed by Freescale and are subject to change without notice.

NOTE

The part is specified and tested over the 5 V and 3.3 V ranges. For the intermediate range, generally the electrical specifications for the 3.3 V range apply, but the part is not tested in production test in the intermediate range.

This appendix provides the most accurate electrical information for the MFR4200 device available at the time of publication.

This introduction is intended to give an overview on several common topics like power supply, current injection etc.

A.1.1 Parameter Classification

The electrical parameters shown in this supplement are guaranteed by various methods. The following classifications are used and the parameters are tagged accordingly in the column labeled “C” in the parameter tables, where appropriate.

- P: Parameters that are guaranteed during production testing on each individual device.
- C: Parameters that are achieved by the design characterization by measuring a statistically relevant sample size across process variations.
- T: Parameters that are achieved by design characterization on a small sample size from typical devices under typical conditions unless otherwise noted. All values shown in the typical column are within this category.
- D: Parameters that are derived mainly from simulations.

A.1.2 Power Supply

The MFR4200 uses several pins to supply power to the I/O pins, oscillator and the digital core.

The VDDA, VSSA pair supplies the internal voltage regulator.

The VDDX, VSSX, VDDR and VSSR pairs supply the I/O pins, VDDR supplies also the internal voltage regulator.

VDD2_5 and VSS2_5 are the supply pins for the digital logic, VDDOSC, VSSOSC supply the oscillator.

VDDA, VDDX, VDDR as well as VSSA, VSSX, VSSR are connected by anti-parallel diodes for ESD protection.

NOTE

In the following context, VDD5 is used for either VDDA, VDDR and VDDX; VSS5 is used for either VSSA, VSSR and VSSX unless otherwise noted.

IDD5 denotes the sum of the currents flowing into the VDDA, VDDX and VDDR pins.

VDD is used for VDD2_5 and VDDOSC, VSS is used for VSS2_5 and VSSOSC.

IDD is used for the current flowing into VDD2_5.

A.1.3 Pins

There are four groups of functional pins.

A.1.3.1 3.3V I/O pins

Those I/O pins have a nominal level of 3.3V. This class of pins is comprised of all I/O pins (all MFR4200 pins excluding EXTAL, XTAL and all power supply pins). The internal structure of all those pins is identical, however some of the functionality may be disabled. E.g. for the input-only pins the output drivers are disabled permanently.

A.1.3.2 Oscillator

The pins EXTAL, XTAL dedicated to the oscillator have a nominal 2.5V level. They are supplied by VDDOSC.

A.1.3.3 VDDR

This pin is used to enable the on chip voltage regulator.

A.1.4 Current Injection

Power supply must maintain regulation within operating V_{DD5} or V_{DD} range during instantaneous and operating maximum current conditions. If positive injection current ($V_{in} > V_{DD5}$) is greater than I_{DD5} , the injection current may flow out of VDD5 and could result in external power supply going out of regulation. Ensure external V_{DD5} load will shunt current greater than maximum injection current. This will be the greatest risk when the CC is not consuming power; e.g. if no system clock is present, or if clock rate is very low which would reduce overall power consumption.

A.1.5 Absolute Maximum Ratings

Absolute maximum ratings are stress ratings only. A functional operation under or outside those maxima is not guaranteed. Stress beyond those limits may affect the reliability or cause permanent damage of the device.

This device contains circuitry protecting against damage due to high static voltage or electrical fields; however, it is advised that normal precautions be taken to avoid application of any voltages higher than maximum-rated voltages to this high-impedance circuit. Reliability of operation is enhanced if unused inputs are tied to an appropriate logic voltage level (e.g., either V_{SS5} or V_{DD5}).

Table A-1. Absolute Maximum Ratings¹

Num	Rating	Symbol	Min	Max	Unit
1	I/O, Regulator and Analog Supply Voltage	V_{DD5}	-0.3	6.5	V
2	Digital Logic Supply Voltage ²	V_{DD}	-0.3	3.0	V
3	Oscillator Supply Voltage ²	V_{DDOSC}	-0.3	3.0	V
4	Voltage difference VDDX to VDDR and VDDA	ΔV_{DDX}	-0.3	0.3	V
5	Voltage difference VSSX to VSSR and VSSA	ΔV_{SSX}	-0.3	0.3	V
6	Digital I/O Input Voltage	V_{IN}	-0.3	6.5	V
7	EXTAL, XTAL inputs	V_{ILV}	-0.3	3.0	V
8	Instantaneous Maximum Current Single pin limit for all digital I/O pins ³	I_D	-25	+25	mA
9	Instantaneous Maximum Current Single pin limit for EXTAL, XTAL ⁴	I_{DL}	-25	+25	mA
10	Operating Temperature Range (packaged)	T_A	-40	+125	°C
11	Operating Temperature Range (junction)	T_J	-40	+150	°C
12	Storage Temperature Range	T_{stg}	-65	155	°C

¹ Beyond absolute maximum ratings device might be damaged.

² The device contains an internal voltage regulator to generate the logic and OSC supply out of the I/O supply. The absolute maximum ratings apply when the device is powered from an external source.

³ All digital I/O pins are internally clamped to V_{SSX} and V_{DDX} , V_{SSR} and V_{DDR} or V_{SSA} and V_{DDA} .

⁴ Those pins are internally clamped to V_{SSOSC} and V_{DDOSC} .

A.1.6 ESD Protection and Latch-up Immunity

All ESD testing is in conformity with CDF-AEC-Q100 Stress test qualification for Automotive Grade Integrated Circuits. During the device qualification ESD stresses were performed for the Human Body Model (HBM), the Machine Model (MM) and the Charge Device Model.

A device will be defined as a failure if after exposure to ESD pulses the device no longer meets the device specification. Complete DC parametric and functional testing is performed per the applicable device specification at room temperature followed by hot temperature, unless specified otherwise in the device specification.

Table A-2. ESD and Latch-up Test Conditions

Model	Description	Symbol	Value	Unit
Human Body	Series Resistance	R1	1500	Ohm
	Storage Capacitance	C	100	pF
	Number of Pulse per pin positive negative	-	- 3 3	
Machine	Series Resistance	R1	0	Ohm
	Storage Capacitance	C	200	pF
	Number of Pulse per pin positive negative	-	- 3 3	
Latch-up	Minimum input voltage limit	-	-2.5	V
	Maximum input voltage limit	-	7.5	V

Table A-3. ESD and Latch-up Protection Characteristics

Num	C	Rating	Symbol	Min	Max	Unit
1	T	Human Body Model (HBM)	V_{HBM}	2000	-	V
2	T	Machine Model (MM)	V_{MM}	200	-	V
3	T	Charge Device Model (CDM)	V_{CDM}	500	-	V
4	T	Latch-up Current at $T_A = 125^\circ\text{C}$ positive negative	I_{LAT}	+100 -100	-	mA
5	T	Latch-up Current at $T_A = 27^\circ\text{C}$ positive negative	I_{LAT}	+200 -200	-	mA

A.1.7 Operating Conditions

This chapter describes the operating conditions of the device. Unless otherwise noted those conditions apply to all the following data.

NOTE

Refer to the temperature rating of the device (C, V, M) with regards to the ambient temperature T_A and the junction temperature T_J . For power dissipation calculations refer to [Section A.1.8, “Power Dissipation and Thermal Characteristics”](#).

Table A-4. Operating Conditions

Rating	Symbol	Min	Typ	Max	Unit
Oscillator and Quartz frequency	f_{OSC}	-	40.000	40.000	MHz
Quartz overtone		Fundamental Frequency			
Quartz frequency stability at T_J	f_{STB}	-1500	300	1500	ppm
Voltage difference VDDX to VDDR and VDDA	D_{VDDX}	-0.1	0	0.1	V
Voltage difference VSSX to VSSR and VSSA	D_{VSSX}	-0.1	0	0.1	V
I/O, Regulator and Analog Supply	V_{DD5}	2.97	3.3	5.5	V
Digital Logic Supply Voltage ¹	V_{DD}	2.25	2.5	2.75	V
Oscillator Supply Voltage ¹	V_{DDOSC}	2.25	2.5	2.75	V
Operating Junction Temperature Range	T_J	-40	-	140	°C
Operating Ambient Temperature Range ²	T_J	-40	27	125	°C

¹ The device contains an internal voltage regulator to generate the logic and OSC supply out of the I/O supply.

² Refer to [Section A.1.8, “Power Dissipation and Thermal Characteristics”](#) for more information about the relation between ambient temperature T_A and device junction temperature T_J .

A.1.8 Power Dissipation and Thermal Characteristics

Power dissipation and thermal characteristics are closely related. The user must assure that the maximum operating junction temperature is not exceeded. The average chip-junction temperature (T_J) in °C can be obtained from:

$$T_J = T_A + (P_D \cdot \Theta_{JA}) \quad \text{Eqn. A-1}$$

T_J = Junction Temperature [°C]

T_A = Ambient Temperature [°C]

P_D = Total Chip Power Dissipation [W]

Θ_{JA} = Package Thermal Resistance [°C/W]

The total power dissipation can be calculated from:

$$P_D = P_{INT} + P_{IO} \quad \text{Eqn. A-2}$$

P_{INT} = Chip Internal Power Dissipation [W]

Two cases with internal voltage regulator enabled and disabled must be considered:

1. Internal Voltage Regulator disabled

$$P_{INT} = I_{DD} \cdot V_{DD} + I_{DDOSC} \cdot V_{DDOSC} + I_{DDA} \cdot V_{DDA} \quad \text{Eqn. A-3}$$

$$P_{IO} = \sum_i R_{DSON} \cdot I_{IO_i}^2 \quad \text{Eqn. A-4}$$

P_{IO} is the sum of all output currents on I/O ports associated with VDDX and VDDR.
For R_{DSON} is valid:

$$R_{DSON} = \frac{V_{OL}}{I_{OL}}; \quad \text{for outputs driven low} \quad \text{Eqn. A-5}$$

respectively

$$R_{DSON} = \frac{V_{DD5} - V_{OH}}{I_{OH}}; \quad \text{for outputs driven high} \quad \text{Eqn. A-6}$$

2. Internal voltage regulator enabled

$$P_{INT} = I_{DDR} \cdot V_{DDR} + I_{DDA} \cdot V_{DDA} \quad \text{Eqn. A-7}$$

I_{DDR} is the current shown in [Table A-8](#) and not the overall current flowing into VDDR, which additionally contains the current flowing into the external loads with output high.

$$P_{IO} = \sum_i R_{DSON} \cdot I_{IO_i}^2 \quad \text{Eqn. A-8}$$

P_{IO} is the sum of all output currents on I/O ports associated with VDDX and VDDR.

Table A-5. Thermal Package Simulation Details

Num	Rating	Symbol	Value	Unit
1	Junction to Ambient LQFP64, single sided PCB ^{1,2} , Natural Convection	$R_{\theta JA}$	67	°C/W
2	Junction to Ambient LQFP64, double sided PCB with 2 internal planes ^{1,3} , Natural Convection	$R_{\theta JMA}$	52	°C/W
3	Junction to Ambient LQFP64 (@200 ft/min), single sided PCB ^{1,3}	$R_{\theta JMA}$	60	°C/W
4	Junction to Ambient LQFP64 (@200 ft/min), double sided PCB with 2 internal planes ^{1,3}	$R_{\theta JMA}$	48	°C/W
5	Junction to Board LQFP64 ⁴	$R_{\theta JB}$	34	°C/W
6	Junction to Case LQFP64 ⁵	$R_{\theta JC}$	17	°C/W
7	Junction to Package Top LQFP64 ⁶ , Natural Convection	Ψ_{JT}	3	°C/W

¹ Junction temperature is a function of die size, on-chip power dissipation, package thermal resistance, mounting site (board) temperature, ambient temperature, air flow, power dissipation of other components on the board, and board thermal resistance.

² Per SEMI G38-87 and EIA/JEDEC Standard 51-2 with the single layer horizontal PC Board according to EIA/JEDEC Standard 51-3

³ Per EIA/JEDEC Standard 51-6 with the four layer horizontal PC Board (double-sided PCB with two internal planes) according to EIA/JEDEC Standard 51-7

⁴ Thermal resistance between the die and the printed circuit board per EIA/JEDEC Standard 51-8. Board temperature is measured on the top surface of the board near the package.

⁵ Thermal resistance between the die and the case top surface as measured by the cold plate method (MIL SPEC-883 Method 1012.1).

⁶ Thermal characterization parameter indicating the temperature difference between package top and the junction temperature per EIA/JEDEC Standard 51-2.

A.1.9 I/O Characteristics

This section describes the characteristics of all 3.3V I/O pins. All parameters are not always applicable, e.g. not all pins feature pullup/pulldown resistances.

Table A-6. 5V I/O Characteristics ($V_{DD5} = 5V$)

Conditions are shown in [Figure A-4](#), unless otherwise noted.

Num	C	Rating	Symbol	Min	Typ	Max	Unit
1	P	Input High Voltage	V_{IH}	$0.65 \cdot V_{DD5}$	-	-	V
	T	Input High Voltage	V_{IH}	-	-	$V_{DD5} + 0.3$	V
2	P	Input Low Voltage	V_{IL}	-	-	$0.35 \cdot V_{DD5}$	V
	T	Input Low Voltage	V_{IL}	$V_{SS5} - 0.3$	-	-	V
3	C	Input Hysteresis	V_{HYS}	-	250	-	mV
4	P	High Impedance (Off-state) Leakage Current $V_{IN} = V_{DD}$ or V_{SS} , all input/output and output pins	I_{IN}	-2.5	-	+2.5	μA
5	P	Output High Voltage (pins in output mode) @50% Partial Drive $I_{OH} = -2mA$	V_{OH}	$V_{DD5} - 0.8$	-	-	V
6	P	Output High Voltage (pins in output mode) @100% Full Drive $I_{OH} = -10mA$	V_{OH}	$V_{DD5} - 0.8$	-	-	V
7	P	Output Low Voltage (pins in output mode) @50% Partial Drive $I_{OL} = +2mA$	V_{OL}	-	-	0.8	V
8	P	Output Low Voltage (pins in output mode) @100% Full Drive $I_{OL} = +10mA$	V_{OL}	-	-	0.8	V
9	P	Internal Pullup Device Current, tested at V_{IL} Max	I_{PUL}	-	-	-130	μA
10	P	Internal Pullup Device Current, tested at V_{IH} Min.	I_{PUH}	-10	-	-	μA
11	P	Internal Pulldown Device Current, tested at V_{IH} Min.	I_{PDH}	-	-	130	μA
12	P	Internal Pulldown Device Current, tested at V_{IL} Max	I_{PDL}	10	-	-	μA
13	d	Input Capacitance (input, input/output pins)	C_{IN}	-	7	-	pF
14	T	Injection Current ¹					
		Single Pin Limit	I_{ICS}	-2.5	-	2.5	mA
		Total Device Limit. Sum of all injected currents	I_{ICP}	-25	-	25	
15	P	Load Capacitance	C_L	-	-		pF
		50% Partial Drive				25	
		100% Full Drive				50	

¹ Refer to [Section A.1.4, "Current Injection"](#), for more information.

Table A-7. 3.3V I/O Characteristics ($V_{DD5} = 3.3V$)

Conditions are $V_{DDX}=3.3V \pm 10\%$ Temperature from $-40^{\circ}C$ to $+140^{\circ}C$, unless otherwise noted

Num	C	Rating	Symbol	Min	Typ	Max	Unit
1	P	Input High Voltage	V_{IH}	$0.65 \cdot V_{DD5}$	-	-	V
	T	Input High Voltage	V_{IH}	-	-	$V_{DD5}+0.3$	V
2	P	Input Low Voltage	V_{IL}	-	-	$0.35 \cdot V_{DD5}$	V
	T	Input Low Voltage	V_{IL}	$V_{SS5}-0.3$	-	-	V
3	C	Input Hysteresis	V_{HYS}	-	250	-	mV
4	P	High Impedance (Off-state) Leakage Current $V_{IN}=V_{DD}$ or V_{SS} , all input/output and output pins	I_{IN}	-2.5	-	+2.5	μA
5	P	Output High Voltage (pins in output mode) @50% Partial Drive $I_{OH} = -0.75mA$	V_{OH}	$V_{DD5}-0.4$	-	-	V
6	P	Output High Voltage (pins in output mode) @100% Full Drive $I_{OH} = -4.5mA$	V_{OH}	$V_{DD5}-0.4$	-	-	V
7	P	Output Low Voltage (pins in output mode) @50% Partial Drive $I_{OL} = +0.9mA$	V_{OL}	-	-	0.4	V
8	P	Output Low Voltage (pins in output mode) @100% Full Drive $I_{OL} = +5.5mA$	V_{OL}	-	-	0.4	V
9	P	Internal Pullup Device Current, tested at V_{IL} Max	I_{PUL}	-	-	-60	μA
10	P	Internal Pullup Device Current, tested at V_{IH} Min.	I_{PUH}	-6	-	-	μA
11	P	Internal Pulldown Device Current, tested at V_{IH} Min.	I_{PDH}	-	-	60	μA
12	P	Internal Pulldown Device Current, tested at V_{IL} Max	I_{PDL}	6	-	-	μA
13	D	Input Capacitance (input, input/output pins)	C_{IN}	-	7	-	pF
14	T	Injection Current ¹					
		Single Pin Limit	I_{ICS}	-2.5	-	2.5	mA
		Total Device Limit. Sum of all injected currents	I_{ICP}	-25	-	25	
15	P	Load Capacitance	C_L	-	-		pF
		50% Partial Drive				25	
		100% Full Drive				50	

¹ Refer to [Section A.1.4, "Current Injection"](#) for more information.

A.1.10 Supply Currents

This section describes the current consumption characteristics of the device as well as the conditions for the measurements.

A.1.10.1 Measurement Conditions

All measurements are without output loads. Unless otherwise noted the currents are measured with internal voltage regulator enabled and a 40 MHz oscillator in standard Pierce mode. Production testing is performed using a square wave signal at the EXTAL input.

Table A-8. Supply Current Characteristics

Conditions are shown in Table A-4 unless otherwise noted								
Num	C	Rating		Symbol	Min	Typ	Max	Unit
1	P	Run supply currents Internal regulator enabled	-40°C	I_{DD5}	-	-	49.901	mA
			25°C		-	-	50.563	
			70°C		-	-	TBD	
			85°C		-	-	TBD	
			100°C		-	-	TBD	
			105°C		-	-	TBD	
			120°C		-	-	TBD	
			125°C		-	-	TBD	
			140°C		-	-	51.047	

A.2 Voltage Regulator (VREG)

A.2.1 Operating Conditions

Table A-9. Voltage Regulator - Operating Conditions

Conditions are shown in Table A-4 unless otherwise noted							
Num	C	Characteristic	Symbol	Min	Typical	Max	Unit
1	P	Input Voltages	$V_{VDDR,A}$	2.97	—	5.5	V
2	P	Regulator Current Shutdown Mode	I_{REG}	—	TBD	40	μ A
3	P	Output Voltage Core Full Performance Mode Shutdown Mode	V_{DD}	2.45 —	2.5 — ¹	2.75 —	V V
4	P	Output Voltage OSC Full Performance Mode Shutdown Mode	V_{DDOSC}	2.35 —	2.5 — ²	2.75 —	V V
5	P	Low Voltage Reset ³ Assert Level	V_{LVRA}	2.25	—	—	V
6	C	Power-on Reset ⁴ Assert Level Deassert Level	V_{PORA} V_{PORD}	0.97 —	— —	— 2.05	V V

¹ High Impedance Output

² High Impedance Output

³ Monitors V_{DD} , always active

⁴ Monitors V_{DD} , always active

A.2.2 Chip Power-up and Voltage Drops

Voltage regulator sub modules POR (power-on reset) and LVR (low voltage reset) handle chip power-up or drops of the supply voltage. Their function is described in [Figure A-1](#).

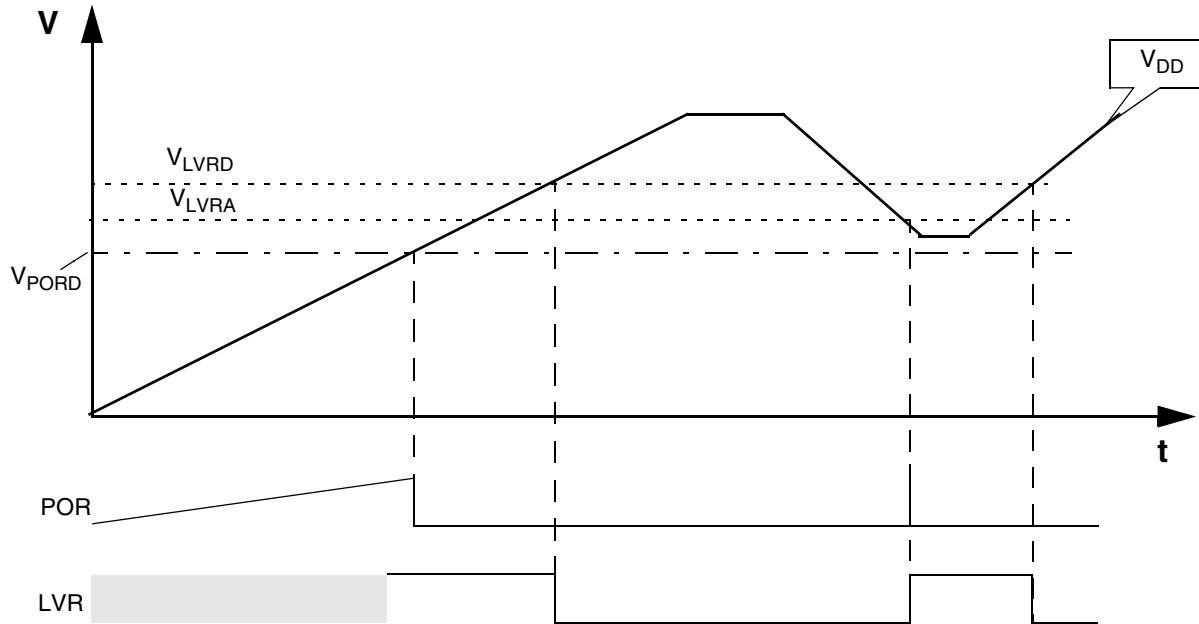

Figure A-1. Voltage Regulator — Chip Power-up and Voltage Drops (not scaled)

A.2.3 Output Loads

A.2.3.1 Resistive Loads

On-chip voltage regulator intended to supply the internal logic and oscillator circuits allows no external DC loads.

A.2.3.2 Capacitive Loads

The capacitive loads are specified in [Figure A-10](#). Ceramic capacitors with X7R dielectricum are required

Table A-10. Voltage Regulator Recommended Capacitive Loads

Num	Characteristic	Symbol	Min	Typical	Max	Unit
1	VDD external capacitive load	C_{DDext}	200	440	12000	nF
3	VDDOSC external capacitive load	$C_{DDOSCext}$	90	220	5000	nF

A.3 Reset and Oscillator

This section summarizes the electrical characteristics of the various startup scenarios for the Oscillator.

A.3.1 Startup

Table A-11 summarizes several startup characteristics explained in this section. Detailed description of the startup behavior can be found in the MFR4200 Clock and Reset Generator (CRG) Block User Guide.

Table A-11. Startup Characteristics

Conditions are shown in Table A-4 unless otherwise noted							
Num	C	Rating	Symbol	Min	Typ	Max	Unit
1	T	POR release level	V_{PORR}	-	-	2.07	V
2	T	POR assert level	V_{PORA}	0.97	-	-	V
3	D	Reset input pulse width, minimum input time	PW_{RSTL}	2	-	-	t_{osc}
4	D	Startup from external reset negation	n_{PSST}	25	27	30	n_{osc}

A.3.1.1 POR

The release level V_{PORR} (see Table A-9) and the assert level V_{PORA} (see Table A-9) are derived from the V_{DD} Supply. They are also valid if the device is powered externally. After releasing the POR reset the oscillator is started. The fastest startup time possible is given by n_{uposc} . There is no clock monitoring function implemented.

A.3.1.2 LVR

The assert level V_{LVRA} (see Table A-9) is derived from the V_{DD} Supply. The fastest startup time possible is given by n_{uposc} . There is no clock monitoring function implemented.

A.3.1.3 External Reset

When external reset is asserted for a time greater than PW_{RSTL} the CRG module generates an internal reset, and the CC starts operations without doing a clock quality check, if there was an oscillation before reset.

A.3.2 Oscillator

The device features an internal Pierce oscillator. The device does not have a clock monitor.

Table A-12. Oscillator Characteristics

Conditions are shown in Table A-4 unless otherwise noted							
Num	C	Rating	Symbol	Min	Typ	Max	Unit
1	C	Crystal oscillator range (Pierce) ¹	f_{OSC}	0.5	-	40	MHz
2	P	Startup Current	i_{OSC}	100	-	-	μA
3	C	Oscillator start-up time	t_{UPOSC}	-	-	TBD	ms
6	P	External square wave input frequency	f_{EXT}	0.5	-	50	MHz
7	D	External square wave pulse width low	t_{EXTL}	9.5	-	-	ns
8	D	External square wave pulse width high	t_{EXTH}	9.5	-	-	ns
9	D	External square wave rise time	t_{EXTR}	-	-	1	ns
10	D	External square wave fall time	t_{EXTF}	-	-	1	ns
11	D	Input Capacitance (EXTAL, XTAL pins)	C_{IN}	-	7	-	pF
12	C	DC Operating Bias in Pierce mode on EXTAL Pin	V_{DCBIAS}	-	TBD	-	V

¹ Depending on the crystal a damping series resistor might be necessary

A.4 AMI Interface Timing Diagram

The CC AMI Interface read/write timing diagram is shown on the [Figure A-2](#).

- Writing to the device is accomplished when Chip Enable(CE#) and Write Enable (WE#) inputs are low (asserted).
- Reading from the device is accomplished when Chip Enable (CE#) and Output Enable (OE#) are low (asserted) while the Write Enable (WE#) is high (negated).
- The input/output pins (D[15:0]) are in a high-impedance state when the device is not selected (CE# is high), the outputs are disabled (OE# is high) or during a write operation (CE# is low, WE# is low).

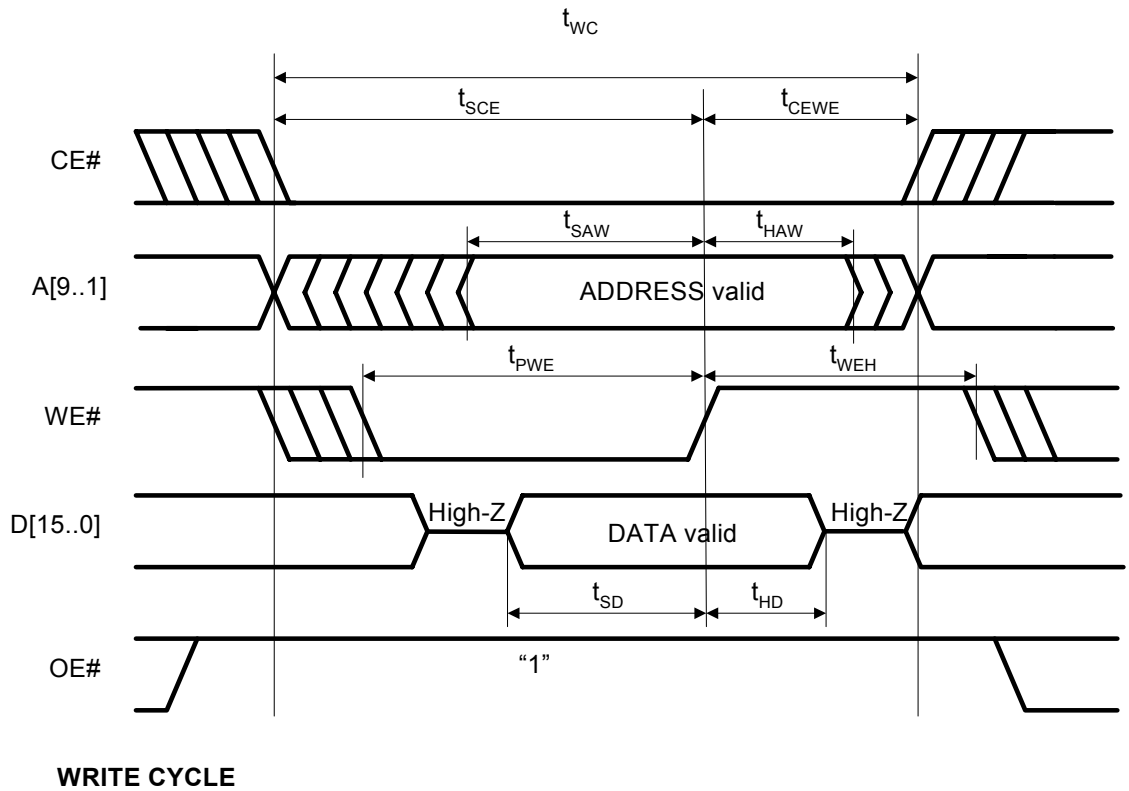
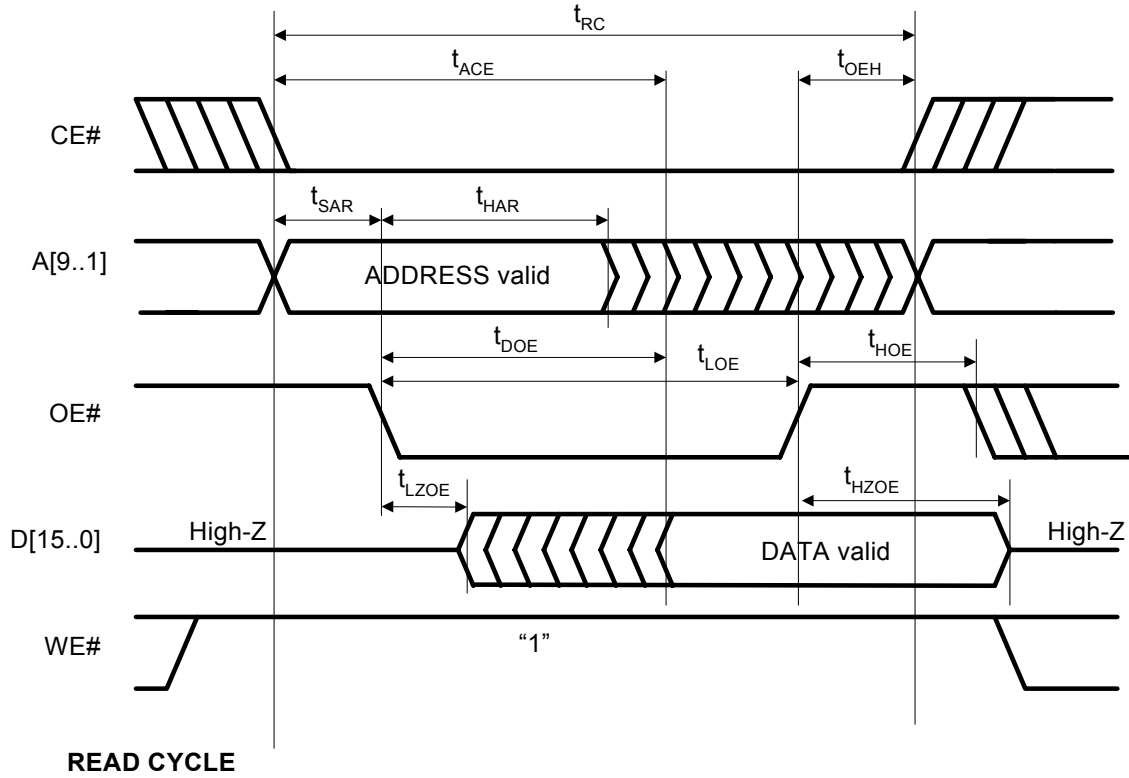

Figure A-2. AMI Interface Read and Write Timing Diagrams

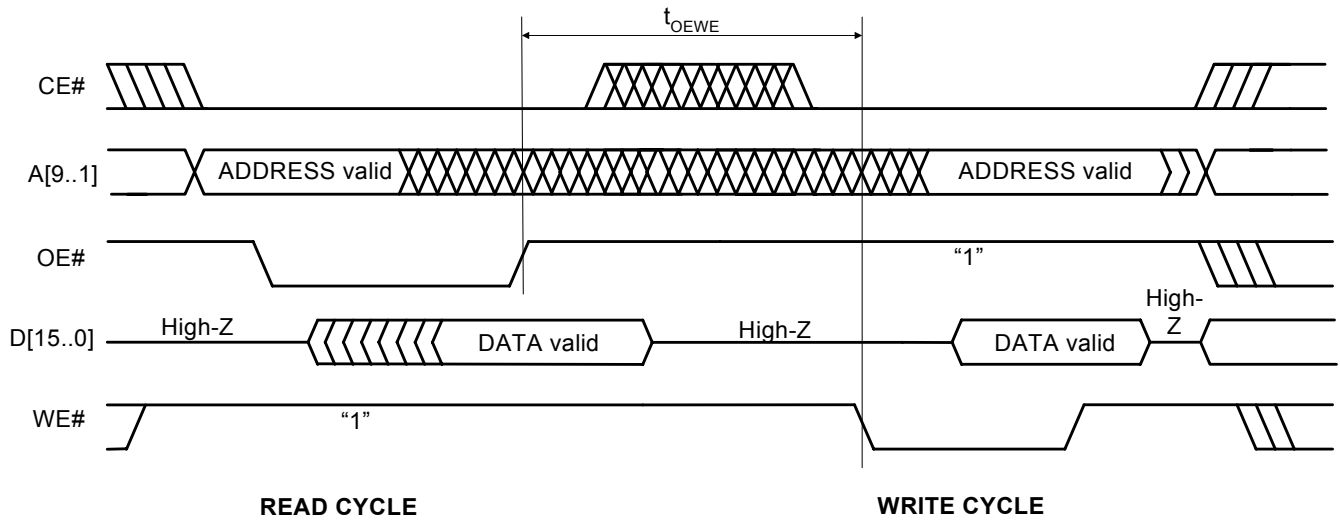

Figure A-3. AMI Interface Write-after-Read Transactions Timing Diagram

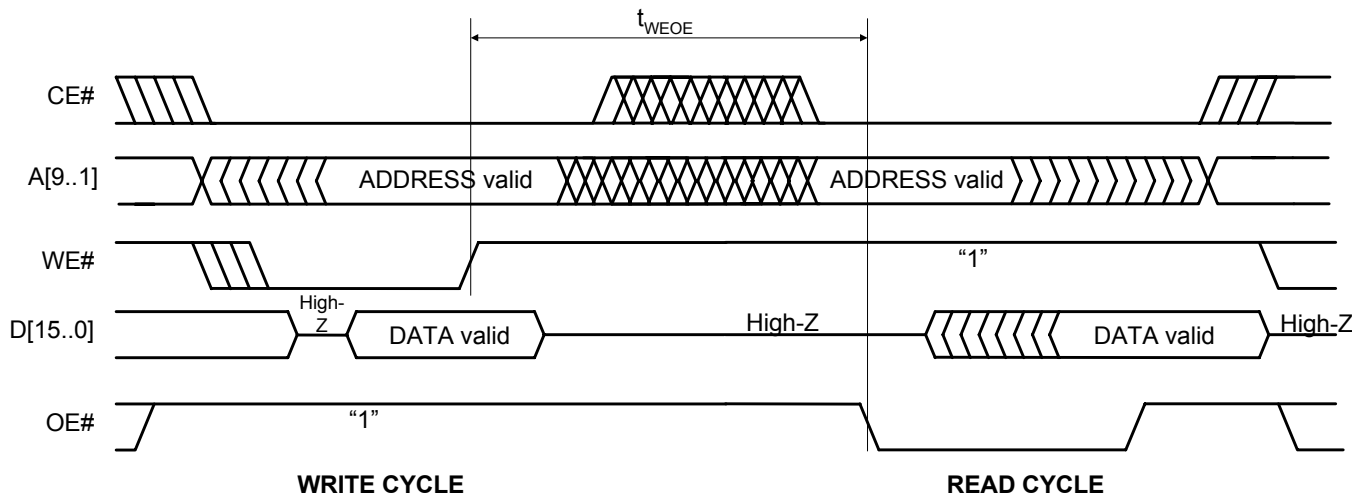

Figure A-4. AMI Interface Read-after-Write Transactions Timing Diagram

Table A-13. AMI Interface AC Switching Characteristics over the Operating Range

Characteristic	Symbol	Min	Max	Unit
Read Cycle				
Read Time Cycle	t_{RC}	155	-	ns
Address Setup Read	t_{SAR}	5	-	ns
Address Hold Read	t_{HAR}	50	-	ns
OE# LOW to Data valid	t_{DOE}	-	145	ns
OE# high time	t_{HOE}	30	-	ns
OE# low time	t_{LOE}	150	-	ns
OE# LOW to Low-Z	t_{LZOE}	20	-	ns
OE# HIGH to High-Z	t_{HZOE}	-	15	ns
OE# HIGH to CE# HIGH	$t_{OE#H}$	0	-	ns
WE# HIGH to OE# LOW	t_{WEOE}	80	-	ns
Write Cycle				
Write Time Cycle	t_{WC}	50	-	ns
Address Setup Write	t_{SAW}	30	-	ns
Address Hold Write	t_{HAW}	5	-	ns
CE# LOW to Write End	t_{SCE}	50	-	ns
Data Set-up to Write End	t_{SD}	30	-	ns
Data Hold from Write End	t_{HD}	5	-	ns
WE# Pulse Width	t_{PWE}	30	-	ns
WE# high time	t_{WEH}	55	-	ns
Write End to CE# high	t_{CEWE}	30	-	ns
OE# HIGH to WE# LOW	t_{OEWE}	15	-	ns

A.5 HCS12 Interface Timing Diagram

The HCS12 device external bus is synchronous with clock frequency up to 8 MHz. Signals are sampled on the both ECLK# edges (see Figure A-5).

The HCS12 host addresses the CC as a slow memory device. Due to that the HCS12 ECLK external clock signal must be stretched. In the MFR4200 the output ECLK clock must be stretched by 3 periods of the HCS12 internal bus-rate clock.

The CC HCS12 Interface read/write timing diagram is shown in Figure A-5.

For more information regarding the HCS12 and HCS12 programming, refer to the HCS12 V1.5 core user guide, available at http://www.freescale.com/files/microcontrollers/doc/ref_manual/S12CPU15UG.pdf.

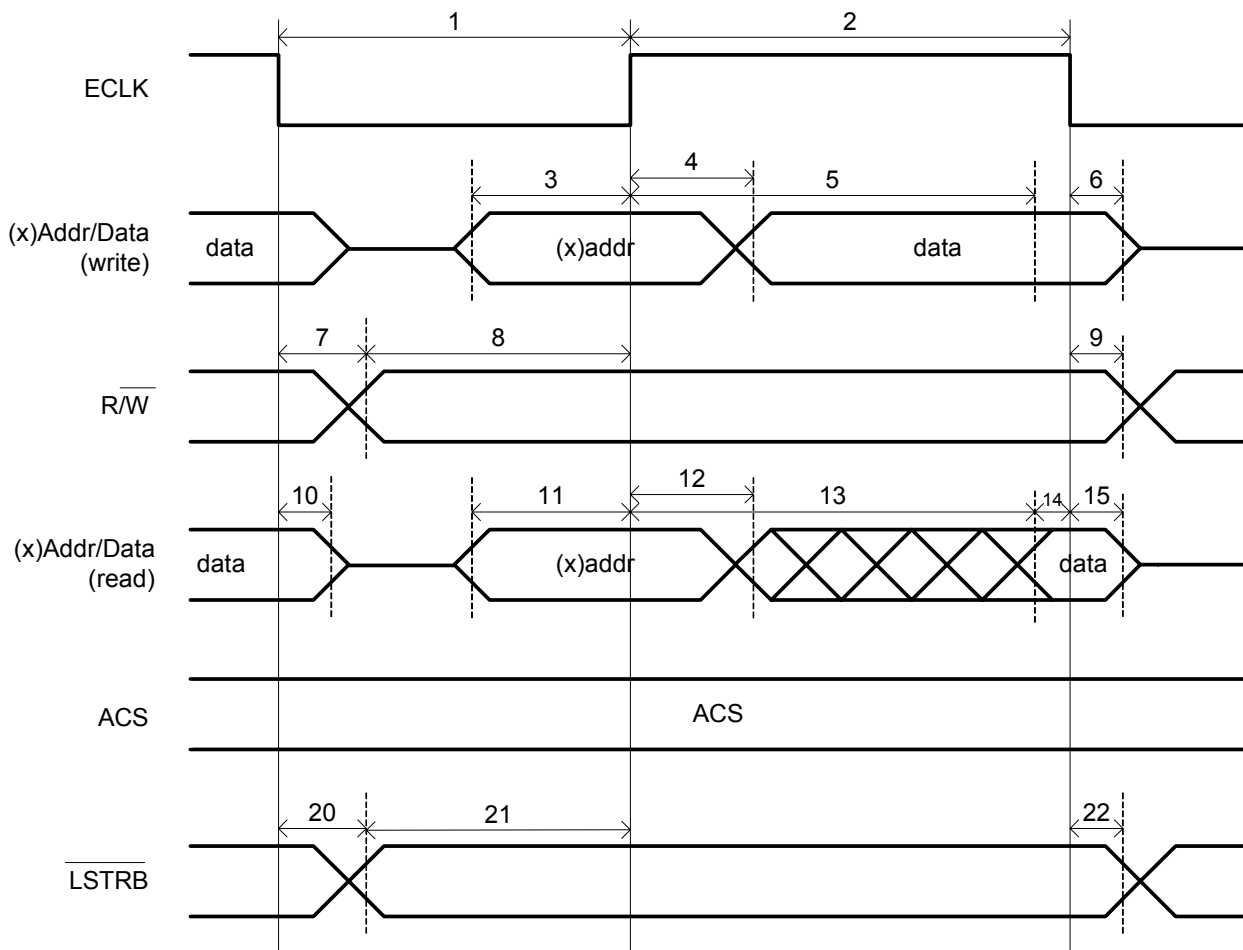

Figure A-5. HCS12 Interface Read/write Timing Diagram

Table A-14. HCS12 Interface Timing Parameters

Num	Rating	Min		Max		Units	Restriction ¹
1	Pulse width, ECLK Low	1/CC_CLK	{25} ^{2 3}	-	-	ns	CC
2	Pulse width, ECLK High	4/CC_CLK	{100}+[14]	-	-	ns	CC
3,11	Address valid time to E rise ⁴	-	11	-	-	ns	HCS12
4	Write data delay time	-	-	-	7	ns	HCS12
5	ECLK rise to write data invalid	3/CC_CLK	{75}-[4]	-	-	ns	CC
6(4)	Write data hold time	-	2	-	-	ns	HCS12
7	RW delay time	-	-	-	7	ns	HCS12
8	RW valid time to ECLK rise	-	14	-	-	ns	HCS12
9	RW hold time	-	2	-	-	ns	HCS12
10	Data hold to address	-	2	-	-	ns	HCS12
12	Multiplexed address hold time	-	2	-	-	ns	HCS12
13	ECLK high access time (ECLK high to Read Data valid)	2/CC_CLK	{50}	3/CC_CLK	{75}	ns	CC
14	Read data setup time	-	13	-	-	ns	HCS12
15	Read data hold time	-	0	-	-	ns	HCS12
20	Low strobe delay time	-	-	-	7	ns	HCS12
21	Low strobe valid to ECLK rise	-	14	-	-	ns	HCS12
22	Low strobe hold time	-	2	-	-	ns	HCS12

¹ Column Restriction:

- CC limitation by the Communication Controller but complies to HCS12.

- HCS12 limitation because of HCS12 specification.

² { .. } - values in ns if the CC_CLK = 40 MHz.

³ If the parameter is not met then ECLK signal deassertion cannot be sampled and the write/read window cannot be calculated.

⁴ (X)Addr and LSTRB are taken over by the controller with the rising edge of the ECLK.

Appendix B

Package Information

B.1 64-pin LQFP package

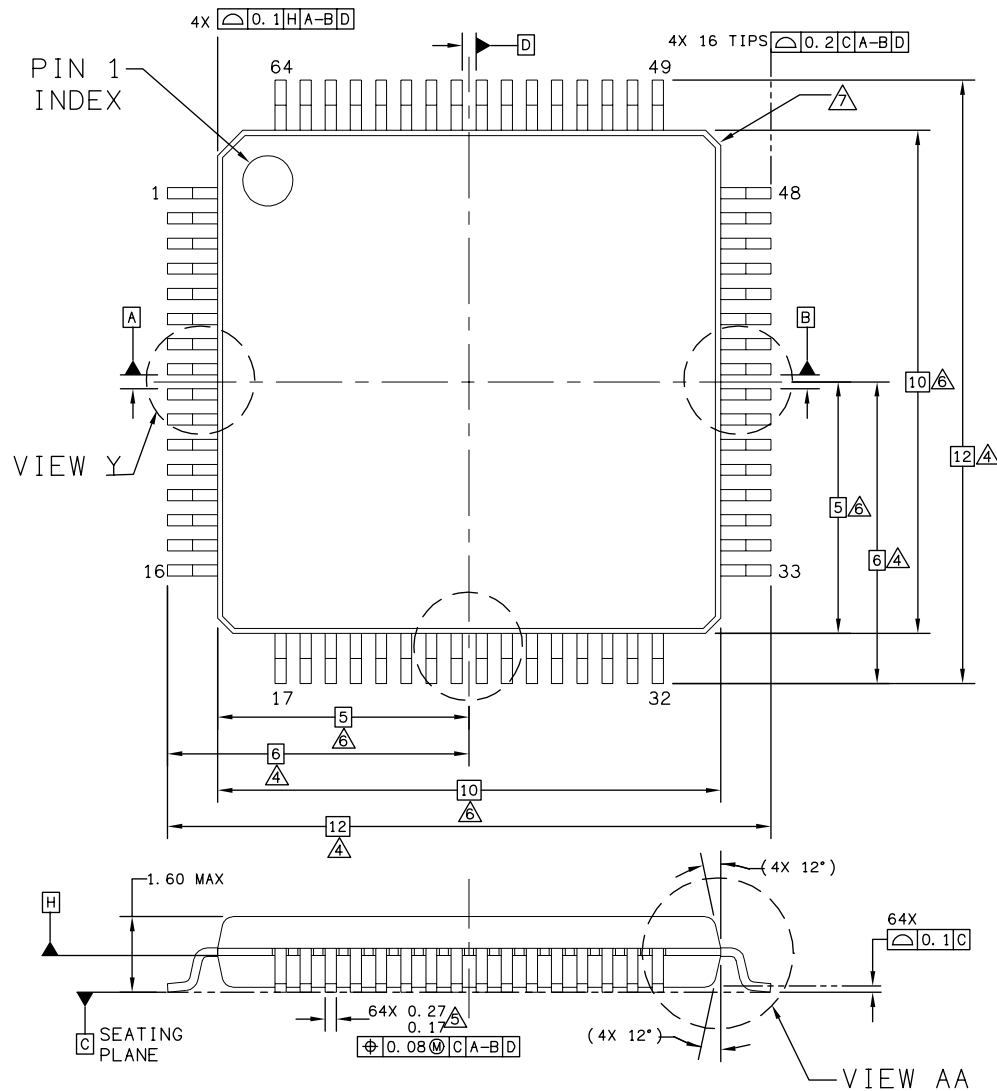

© FREESCALE SEMICONDUCTOR, INC. ALL RIGHTS RESERVED.	MECHANICAL OUTLINE	PRINT VERSION NOT TO SCALE	
TITLE: 64LD LQFP, 10 X 10 X 1.4 PKG, 0.5 PITCH, CASE OUTLINE	DOCUMENT NO: 98ASS23234W	REV: D	
	CASE NUMBER: 840F-02	06 APR 2005	
	STANDARD: JEDEC MS-026 BCD		

Figure B-1. 64-pin LQFP Mechanical Dimensions (Case N 840F-02) (Page 1)

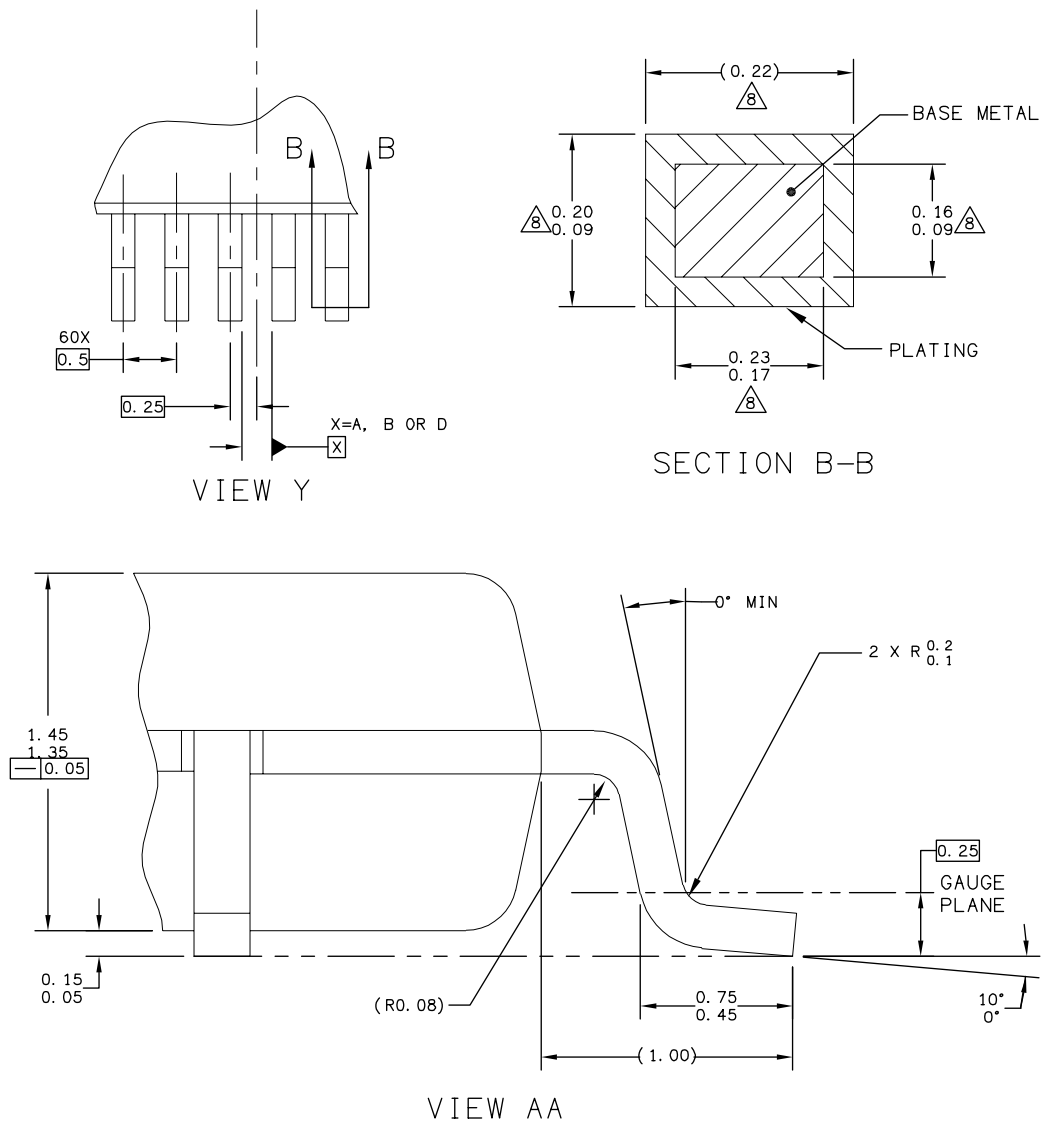

© FREESCALE SEMICONDUCTOR, INC. ALL RIGHTS RESERVED.	MECHANICAL OUTLINE	PRINT VERSION NOT TO SCALE
TITLE: 64LD LQFP, 10 X 10 X 1.4 PKG, 0.5 PITCH, CASE OUTLINE	DOCUMENT NO: 98ASS23234W	REV: D
	CASE NUMBER: 840F-02	06 APR 2005
	STANDARD: JEDEC MS-026 BCD	

Figure B-2. 64-pin LQFP Mechanical Dimensions (Case N 840F-02) (Page 2)

NOTES:

1. DIMENSIONS ARE IN MILLIMETERS.
2. DIMENSIONING AND TOLERANCING PER ASME Y14.5M-1994.
3. DATUMS A, B AND D TO BE DETERMINED AT DATUM PLANE H.
4. DIMENSIONS TO BE DETERMINED AT SEATING PLANE C.
5. THIS DIMENSION DOES NOT INCLUDE DAMBAR PROTRUSION. ALLOWABLE DAMBAR PROTRUSION SHALL NOT CAUSE THE LEAD WIDTH TO EXCEED THE UPPER LIMIT BY MORE THAN 0.08 mm AT MAXIMUM MATERIAL CONDITION. DAMBAR CANNOT BE LOCATED ON THE LOWER RADIUS OR THE FOOT. MINIMUM SPACE BETWEEN PROTRUSION AND ADJACENT LEAD SHALL NOT BE LESS THAN 0.07 mm.
6. THIS DIMENSION DOES NOT INCLUDE MOLD PROTRUSION. ALLOWABLE PROTRUSION IS 0.25 mm PER SIDE. THIS DIMENSION IS MAXIMUM PLASTIC BODY SIZE DIMENSION INCLUDING MOLD MISMATCH.
7. EXACT SHAPE OF EACH CORNER IS OPTIONAL.
8. THESE DIMENSIONS APPLY TO THE FLAT SECTION OF THE LEAD BETWEEN 0.1 mm AND 0.25 mm FROM THE LEAD TIP.

© FREESCALE SEMICONDUCTOR, INC. ALL RIGHTS RESERVED.	MECHANICAL OUTLINE	PRINT VERSION NOT TO SCALE	
TITLE: 64LD LQFP, 10 X 10 X 1.4 PKG, 0.5 PITCH, CASE OUTLINE	DOCUMENT NO: 98ASS23234W	REV: D	
	CASE NUMBER: 840F-02	06 APR 2005	
	STANDARD: JEDEC MS-026 BCD		

Figure B-3. 64-pin LQFP Mechanical Dimensions (Case N 840F-02) (Page 3)

Appendix C

Printed Circuit Board Layout Recommendations

The PCB must be laid out carefully to ensure proper operation of the voltage regulator and the CC. The following rules must be observed:

- Every supply pair must be decoupled by a ceramic capacitor connected as near as possible to the corresponding pins (Cd).
- The central point of the ground star should be the VSSR pin.
- Low-ohmic low-inductance connections should be used between VSSX and VSSR.
- VSSOSC must be directly connected to VSSR.
- Traces of VSSOSC, EXTAL and XTAL must be kept as short as possible. Occupied board area for C1, C2, C3 and Q should be as small as possible.
- Other signals or supply lines should not be routed under the area occupied by C1, C2, C3, and Q and the connection area of the CC.
- The central power input should be fed in at the VDDA/VSSA pins.

Figure C-1 shows a recommended PCB layout (64-pin LQFP) for standard Pierce oscillator mode, while Table C-1 provides suggested values for the external components.

Table C-1. Suggested External Component Values

Component	Purpose	Type	Value
C1	OSC load cap	ceramic X7R	2pF
C2	OSC load cap	ceramic X7R	2pF
C3	VDDOSC filter cap	ceramic X7R	100– 220nF
C4	VDDA filter cap	ceramic X7R	100– 220nF
Cd	VDDR, VDDX filter cap	ceramic X7R/tantalum	100– 220nF
Cload	VDD2_5 filter cap	ceramic X7R	100– 220nF
R _B	OSC res		1 MOhm
R _S	OSC res		0 Ohm (i.e. short-circuit_
Q	Quartz	NDK NX8045GA	40 MHz

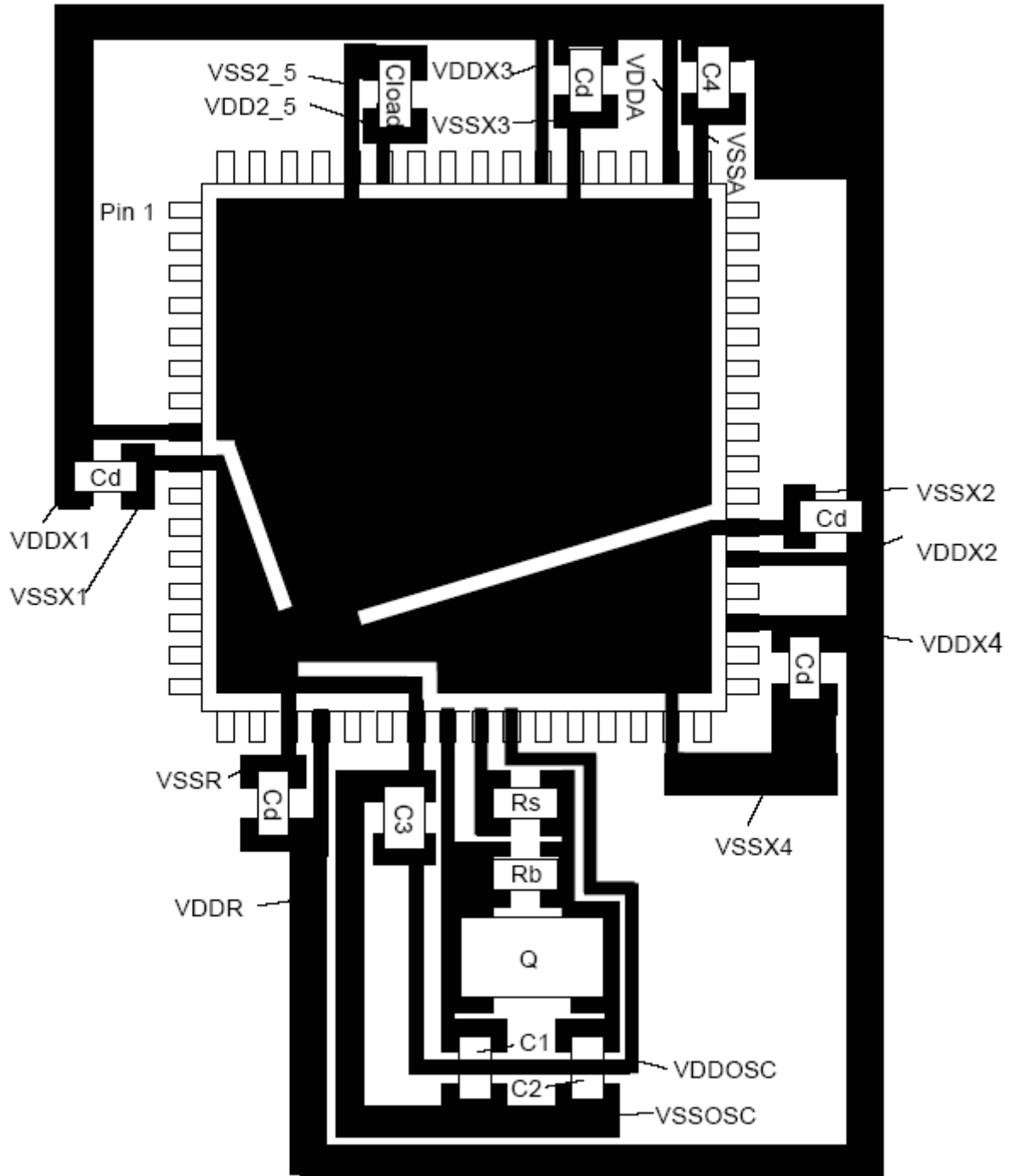

Figure C-1. Recommended PCB Layout (64-pin LQFP) for Standard Pierce Oscillator Mode

Appendix C

MFR4200 Protocol Implementation Document

C.1 Introduction

C.1.1 Purpose

This document is an appendix to the MFR4200 FlexRay Microcontroller data sheet (MFR4200V2). It describes the FlexRay protocol implementation in the MFR4200.

C.1.2 Structure

This appendix follows the structure of the FlexRay Communications System Protocol Specification V1.1 (PS V1.1). Each section explains whether the implementation in the MFR4200 is identical to the PS V1.1 or is realized with an intermediate solution. Where only the section headline is provided, the implementation is compliant with the PS V1.1.

C.1.3 References

1. FlexRay Communications System Protocol Specification V1.1 (intermediate consortium baseline) (PS V1.1/PWD)
2. MFR4200 FlexRay Microcontroller Data Sheet (MFR4200V2)

C.2 Overall Protocol State Machine

The MFR4200 implements the overall protocol state machine according to PS V1.1/PWD, with differences presented below.

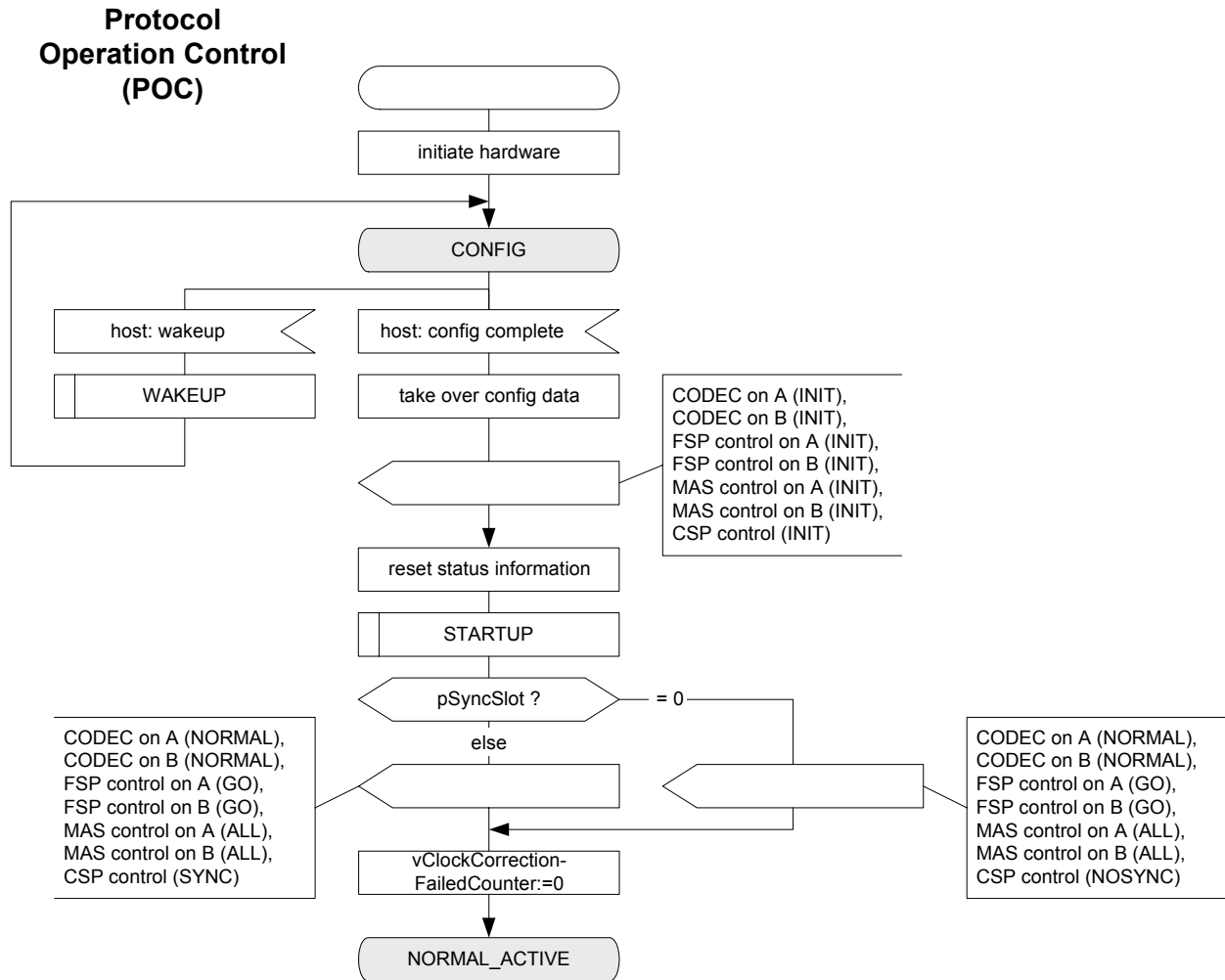

Figure C-1. Protocol Operation Control (POC) - 1

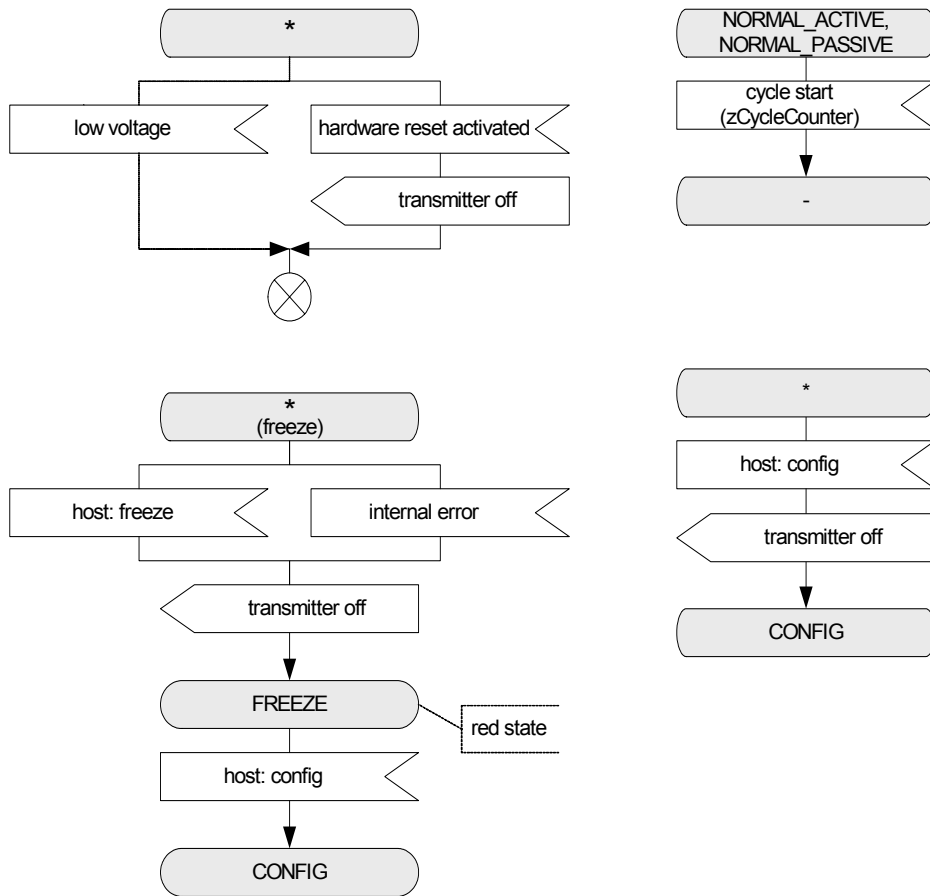

Figure C-2. Protocol Operation Control (POC) - 2

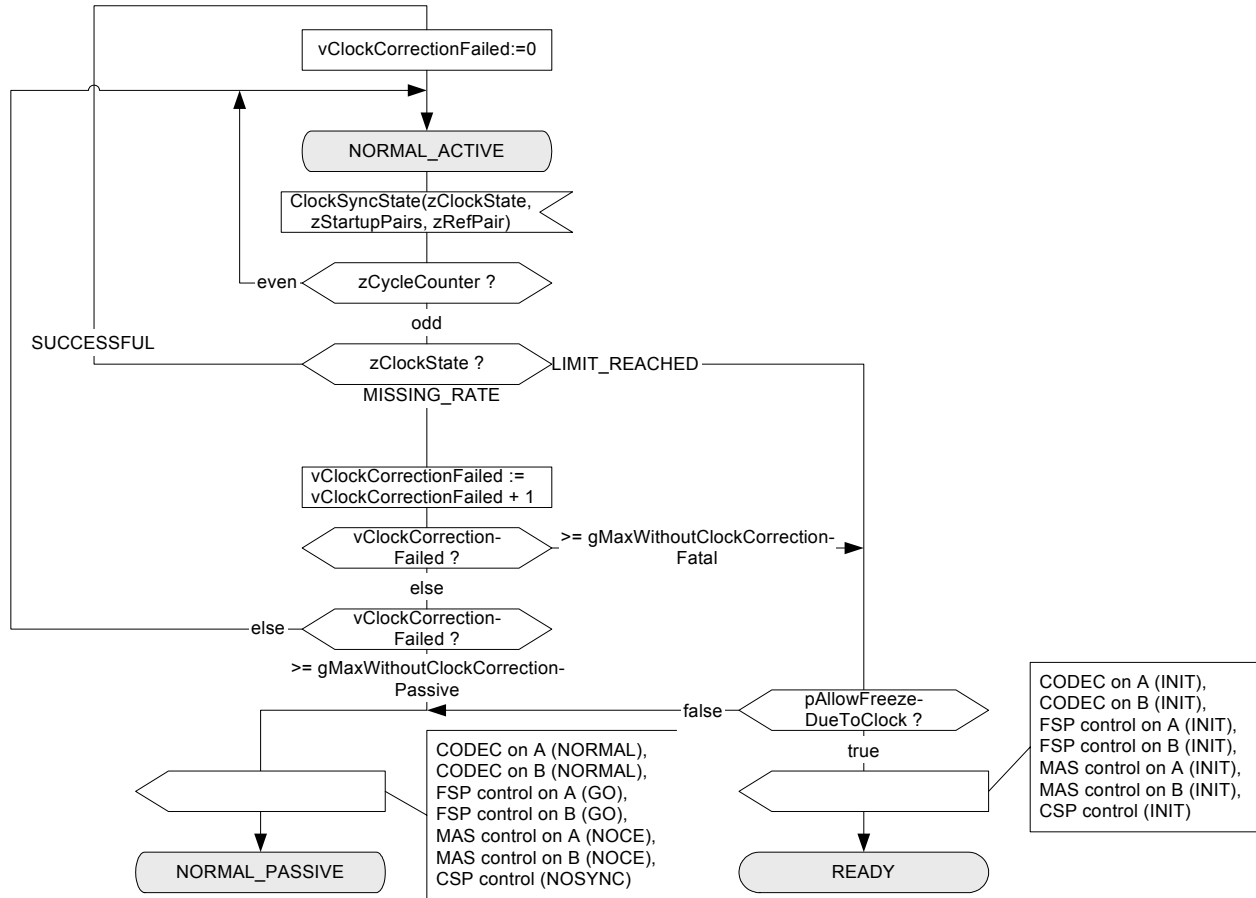

Figure C-3. POC — Normal Operation

C.3.3 NRZ Decoding

The implementation is compliant with PS V1.1.

C.3.3.1 NFZ Decoding Principles

The implementation is compliant with PS V1.1.

C.3.3.2 Frame Decoding

The implementation is compliant with PS V1.1.

C.3.3.3 Symbol Decoding

The implementation is compliant with PS V1.1.

C.3.3.3.1 Collision Resolution Symbol

The implementation is compliant with PS V1.1.

C.3.3.3.2 Wakeup Symbol

MFR4200 can generate a wakeup symbol in accordance with [Section C.3.2, “NRZ Coding”](#). However, the implementation does not recognize a wakeup symbol. See also [Section C.7.2, “Cluster Wakeup”](#).

C.3.3.4 Decoding Error

The implementation is compliant with PS V1.1.

C.3.4 Signal Integrity

The implementation is compliant with PS V1.1.

C.4 Frame Format

The implementation is compliant with PS V1.1.

NOTE

The semantic of the null frame bit has been inverted compared with previous implementations, to be compliant with PS V1.1.

C.5 Media Access Control

The implementation is compliant with PS V1.1.

NOTE

Due to the implementation, there is a lower boundary *gdNIT* (see [Section 3.2.3.3.18, “Network Idle Time Configuration Register \(NITCR\)”](#)).

C.6 Frame and Symbol Processing

The implementation is compliant with PS V1.1, with the following exceptions.

- STUP is not indicated to the host.
- Data received during startup is not provided to the host.

C.7 Wakeup, Startup, and Reintegration

C.7.1 Introduction

The implementation is compliant with PS V1.1.

C.7.2 Cluster Wakeup

The functionality of the wakeup is implemented in part only. The controller can generate wakeup symbols on configurable channels and repeat them for a configurable number of times in accordance with WAKEUP SEND.

WAKEUP LISTEN is not implemented. After completing WAKEUP SEND, the controller returns to the CONFIG state.

C.7.3 Communication Startup and Reintegration

Clearing the coldstart inhibit bit after leaving 'PC_RESET' is not supported in MFR4200. This applies for the following subsections.

C.7.3.1 Definitions and Properties

The implementation is compliant with PS V1.1.

C.7.3.2 Principle of Operation

The implementation is compliant with PS V1.1.

C.7.3.3 Coldstart Inhibit Mode

The implementation is compliant with PS V1.1.

C.7.3.4 Startup State Diagram

The implementation is compliant with PS V1.1. However, the protocol state indicated in the host interface is incorrect for a short time, in the following case:

When the node has unsuccessfully performed a coldstart, and the number of remaining coldstart attempts is 0, the host interface indicates that the controller has entered the coldstart listen state, and will change to the integration listen state only after approximately one macrotick.

Moreover, in Figure 7-6 (PS V1.1), and in similar drawings for nodes B and C, the state *Initialize schedule* lasts until the end of the communication cycle, rather than changing in the middle of the cycle.

C.8 Clock Synchronization

C.8.1 Introduction

The implementation is compliant with PS V1.1.

C.8.2 Time Representation

The implementation is compliant with PS V1.1.

C.8.3 Synchronization Process

Figure 8-3 (PS V1.1): In MFR4200 the measurement tables are initialized during the NIT (before cycle start, rather than after the cycle start). The entries for the even cycle are initialized in the NIT of the odd cycle. Likewise, the measurements of the odd cycle are initialized in the NIT of the even cycle.

C.8.4 Clock Startup

The implementation is compliant with PS V1.1.

C.8.5 Time Measurement

The implementation is compliant with PS V1.1. However, note that the clock sync measurement values indicated in the host interface are different from the example shown in Figure 8-8 (PS V1.1).

C.8.5.1 Data Structure

The implementation is compliant with PS V1.1.

C.8.5.2 Initialization

In MFR4200, the table for the odd cycle measurements is initialized in the NIT of the even cycle, and vice versa, rather than after the beginning of the even cycle.

C.8.6 Correction Term Calculation

Figure 8-13 (PS V1.1): MFR4200 differs slightly from this description. Startup frames are counted on a per channel basis, with one counter for each channel, rather than one counter for both channels. For evaluation, the maximum is taken, rather than counting a startup frame on either channel with a single counter. Moreover, in MFR4200, the check of *vOffsetCorrection* is performed before the external offset correction, rather than after external offset correction.

Figure 8-14 (PS V1.1): In MFR4200 the check of *vRateCorrection* is performed before the external offset correction rather than after external rate correction.

C.8.7 Clock Correction

Figure 8-15 (PS V1.1): The implementation in MFR4200 is compliant with the red text in the middle of the diagram. Moreover, when macrotick counting is reset, the host interface indication of *vMacrotick* is immediately reset to 0, as soon as the macrotick counting is reset; however, internally, the macrotick generation continues for a short time in accordance with the specification.

C.8.8 Sync Frame Configuration Rules

Table 8-3 (PS V1.1): MFR4200 supports up to 16 sync frames, rather than 15.

C.9 Controller Host Interface

The implementation of the host interface is compliant with the specification in PS V1.1. The implementation supports the following features:

- Message filtering
 - Frame ID filtering
 - Cycle counter filtering
 - Channel filtering
 - Message ID filtering (FIFO only)
- Message FIFO (receive FIFO)
- Timer
- Error signalling
- Host interrupts
 - Timer interrupt
 - Error signaling interrupt
- Network management vector

C.10 Device Specific Power Modes

MFR4200 supports supervision of voltage levels, and performs a reset when the supply voltage drops below a boundary specified in [Chapter 5, “Clocks and Reset Generator](#).

A low power mode or sleep mode is not supported.

C.11 Bus Guardian Schedule Monitoring

The implementation is compliant with PS V1.1.

C.12 System Parameters and Configuration Constraints

C.12.1 System Parameters

System parameters are used primarily for the protocol description and are not protocol mechanisms. Therefore, they are almost transparent to the user in the MFR4200 implementation. The only difference from PS V1.1 that is relevant to the user is as follows.

- `cSyncNodeMax` is fixed at 16.

NOTE

Parameters relating to unsupported features are not mentioned here.

C.12.2 Configuration Constraints

The implementation requires most of the constraints specified in PS V1.1 to be fulfilled. Exceptions are bit rate configuration and bit sample clock frequency, which are configurable in a wider range than described in PS V1.1.

NOTE

However, while fulfilling these configuration constraints is necessary, it is not sufficient for a valid configuration.

Appendix D

Index of Registers

A

Active FIFO Buffer Cycle Counter and Payload Length Register (AFBCCPLR) 132
Active FIFO Buffer Data n Register (AFBDATAnR) 133
Active FIFO Buffer Frame ID Register (AFBFRID) 131
Active FIFO Buffer Header CRC Register (AFBCRCR) 132
Active FIFO Buffer Message Buffer Slot Status Vector Register (AFBMBSSVR) 133
Active Receive Buffer Cycle Counter and Payload Length Register (ARBCCPLR) 129
Active Receive Buffer Data n Register (ARBDATAnR) 130
Active Receive Buffer Frame ID Register (ARBFRID) 129
Active Receive Buffer Header CRC Register (ARBCRCR) 130
Active Receive Buffer Message Buffer Slot Status Vector Register (ARBMBSSVR) 131
Active Transmit Buffer Cycle Counter and Payload Length Register (ATBCCPLR) 127
Active Transmit Buffer Data n Register (ATBDATAnR) 128
Active Transmit Buffer Frame ID Register (ATBFRID) 126
Active Transmit Buffer Header CRC Register (ATBCRCR) 127
Active Transmit Buffer Message Buffer Slot Status Vector Register (ATBMBSSVR) 128

B

Bit Duration Register (BDR) 71
Buffer Control, Configuration and Status n Register (BUFCSnR) 126
Bus Guardian Status Register (BGSR) 99
Bus Guardian Tick Register (BGTR) 87

C

Channel Status Error Counter n Register (CSECnR) 102
CHI Error Register (CHIER) 109
Clock Correction Failed Counter Register (CCFCR) 113
Cluster Drift Damping Register (CDDR) 73
Cold Start Maximum Register (CSMR) 84
Current Cycle Counter Value Register (CCCVR) 94
Current Macro-tick Counter Value Register (CMCVR) 94
Cycle Counter Filter n Register (CCFnR) 135
Cycle Length Register (CLR) 80

D

Debug Port Control Register (DBPCR) 88
Delay Compensation Channel A Register (DCAR) 72

Delay Compensation Channel B Register (DCBR) 72
Delay Counter Register (DCR) 87

E

Error Handling Level Register (EHLR) 113
Even Measurement channel A n Register (EMAnR) 122
Even Measurement channel B n Register (EMBnR) 123
Even Measurement Counter Register (EMCR) 124
Even Sync Frame ID n Register (ESFIDnR) 121
External Correction Control Register (ECCR) 82
External Offset Correction Register (EOCR) 81
External Rate Correction Register (ERCR) 82

F

FIFO Acceptance Filter Message ID Mask Register (FAFMIDMR) 136
FIFO Acceptance Filter Message ID Value Register (FAFMIDVR) 136
FIFO Acceptance/Rejection Filter Channel Register (FAFCHR) 137
FIFO Rejection Filter Frame ID Mask Register (FRFFIDMR) 138
FIFO Rejection Filter Frame ID Value Register (FRFFIDVR) 138
FIFO Size Register (FSIZR) 125

G

Global Network Management Vector n Register (GNMVnR) 96

H

Host Interface and Physical Layer Pins Drive Strength Register (HIPDSR) 67
Host Interface Pins PullUp/Down Control Register (HIPPCR) 69
Host Interface Pins PullUp/Down Enable Register (HIPPER) 68

I

Idle Detection Length Register (IDLR) 90
Interrupt Enable Register 0 (IER0) 103
Interrupt Status Register 0 (ISR0) 114

L

Latest Dynamic Transmission Start Register (LDTSR) 78
Listen timeout with Noise Length Register (LNLR) 92

M

Magic Number Register (MNR) 63
Maximum Cycle Length Deviation Register (MCLDAR) 81
Maximum Odd Cycles Without Clock Correction Fatal Register (MOCWCFR) 101
Maximum Odd Cycles Without clock Correction Passive Register (MOCWCPR) 101
Maximum Offset Correction Register (MOCR) 83
Maximum Payload Length Dynamic Register (MPLDR) 79
Maximum Rate Correction Register (MRCR) 84
Maximum Sync Frames Register (MSFR) 73
Microticks per Cycle High Register (MPCHR) 75
Microticks per Cycle Low Register (MPCLR) 74
Minislot Action Point Offset Register (MSAPOR) 77
Minislot Length Register (MSLR) 77
Module Configuration Register 0 (MCR0) 64
Module Configuration Register 1 (MCR1) 66
Module Version Register 0 (MVR0) 62
Module Version Register 1 (MVR1) 62

N

Network Idle Time Configuration Register (NITCR) 80
Network Management Vector Length Register (NMVLR) 85
Nominal Macrotick Length Register (NMLR) 74
Number of Static Slots Register (NSSR) 76

O

Odd Measurement channel A n Register (OMAnR) 121
Odd Measurement channel B n Register (OMBnR) 122
Odd Measurement Counter Register (OMCR) 124
Odd Sync Frame ID n Register (OSFIDnR) 120
Offset Correction Value Register (OCVR) 95

P

Physical Layer Pins Drive Strength Register (PLPDSR) 68
Physical Layer Pins PullUp/Down Control Register (PLPPCR) 70
Physical Layer Pins PullUp/Down Enable Register (PLPPER) 69
Protocol State Register (PSR) 93

R

Rate Correction Value Register (RCVR) 95
Receive Buffer Interrupt Vector Register (RBIVECR) 108

S

Slot Status Counter Condition n Register (SSCCnR) 105
Slot Status Counter Incrementation Register (SSCIR) 107
Slot Status Counter Interrupt Mask Register (SSCIMR) 107
Slot Status Counter n Register (SSCnR) 104
Slot Status n Register (SSnR) 119
Slot Status Selection n Register (SSSnR) 103
Start of Offset Correction Cycle Time Register (SOCCTR) 89
Startup Interrupt Enable Register (SIER) 100
Startup Interrupt Status Register (SISR) 118
Static Payload Length Register (SPLR) 76
Static Slot Action Point Offset Register (SSAPOR) 78
Static Slot Length Register (SSLR) 75
Symbol Window Configuration Register (SWCR) 79
Symbol Window Control Register (SWCTRLR) 90
Symbol Window Status channel A Register (SWSAR) 97
Symbol Window Status channel B Register (SWSBR) 98
Sync Frame Acceptance Filter Mask Register (SYNFAFMR) 134
Sync Frame Acceptance Filter Value Register (SYNFAFVR) 134
Sync Frame Header Register (SYNCHR) 86
Sync Frame Register (SYNCFR) 86
Sync Frame Rejection Filter Register (SYNFRFR) 135

T

Timer Interrupt Configuration Register 0 Cycle Set (TICR0CS) 139
Timer Interrupt Configuration Register 0 Macrotick Offset (TICR0MO) 140
Timer Interrupt Configuration Register 1 Cycle Set (TICR1CS) 140
Timer Interrupt Configuration Register 1 Macrotick Offset (TICR1MO) 141
Transmit Buffer Interrupt Vector Register (TBIVECR) 109
Transmit Start Sequence Length Register (TSSLR) 85

V

Voltage Regulator Status Register (VREGSR) 70

W

Wakeup Mechanism Control Register (WMCTRLR) 91
Wakeup Symbol TX Idle Register (WUSTXIR) 91
Wakeup Symbol TX Low Register (WUSTXLR) 92

How to Reach Us:

Home Page:

www.freescale.com

E-mail:

support@freescale.com

USA/Europe or Locations Not Listed:

Freescale Semiconductor
Technical Information Center, CH370
1300 N. Alma School Road
Chandler, Arizona 85224
+1-800-521-6274 or +1-480-768-2130
support@freescale.com

Europe, Middle East, and Africa:

Freescale Halbleiter Deutschland GmbH
Technical Information Center
Schatzbogen 7
81829 Muenchen, Germany
+44 1296 380 456 (English)
+46 8 52200080 (English)
+49 89 92103 559 (German)
+33 1 69 35 48 48 (French)
support@freescale.com

Japan:

Freescale Semiconductor Japan Ltd.
Headquarters
ARCO Tower 15F
1-8-1, Shimo-Meguro, Meguro-ku,
Tokyo 153-0064, Japan
0120 191014 or +81 3 5437 9125
support.japan@freescale.com

Asia/Pacific:

Freescale Semiconductor Hong Kong Ltd.
Technical Information Center
2 Dai King Street
Tai Po Industrial Estate
Tai Po, N.T., Hong Kong
+800 2666 8080
support.asia@freescale.com

For Literature Requests Only:

Freescale Semiconductor Literature Distribution Center
P.O. Box 5405
Denver, Colorado 80217
1-800-441-2447 or 303-675-2140
Fax: 303-675-2150
LDCForFreescaleSemiconductor@hibbertgroup.com

Information in this document is provided solely to enable system and software implementers to use Freescale Semiconductor products. There are no express or implied copyright licenses granted hereunder to design or fabricate any integrated circuits or integrated circuits based on the information in this document.

Freescale Semiconductor reserves the right to make changes without further notice to any products herein. Freescale Semiconductor makes no warranty, representation or guarantee regarding the suitability of its products for any particular purpose, nor does Freescale Semiconductor assume any liability arising out of the application or use of any product or circuit, and specifically disclaims any and all liability, including without limitation consequential or incidental damages. "Typical" parameters that may be provided in Freescale Semiconductor data sheets and/or specifications can and do vary in different applications and actual performance may vary over time. All operating parameters, including "Typicals", must be validated for each customer application by customer's technical experts. Freescale Semiconductor does not convey any license under its patent rights nor the rights of others. Freescale Semiconductor products are not designed, intended, or authorized for use as components in systems intended for surgical implant into the body, or other applications intended to support or sustain life, or for any other application in which the failure of the Freescale Semiconductor product could create a situation where personal injury or death may occur. Should Buyer purchase or use Freescale Semiconductor products for any such unintended or unauthorized application, Buyer shall indemnify and hold Freescale Semiconductor and its officers, employees, subsidiaries, affiliates, and distributors harmless against all claims, costs, damages, and expenses, and reasonable attorney fees arising out of, directly or indirectly, any claim of personal injury or death associated with such unintended or unauthorized use, even if such claim alleges that Freescale Semiconductor was negligent regarding the design or manufacture of the part.



Freescale™ and the Freescale logo are trademarks of Freescale Semiconductor, Inc. All other product or service names are the property of their respective owners. The ARM POWERED logo is a registered trademark of ARM Limited. ARM7TDMI-S is a trademark of ARM Limited. Java and all other Java-based marks are trademarks or registered trademarks of Sun Microsystems, Inc. in the U.S. and other countries. The Bluetooth trademarks are owned by their proprietor and used by Freescale Semiconductor, Inc. under license.

© Freescale Semiconductor, Inc. 2004. All rights reserved.

MFR4200
Rev. 0
8/2005