

GR15-G ~ GR20-G

HIGH VOLTAGE FAST RECOVERY RECTIFIER

PRV : 1500 - 2000 Volts
I_o : 0.5 Ampere

FEATURES :

- * Glass passivated chip
- * High current capability
- * High surge current capability
- * High reliability
- * Low reverse current
- * Low forward voltage drop
- * Fast switching for high efficiency
- * Pb / RoHS Free

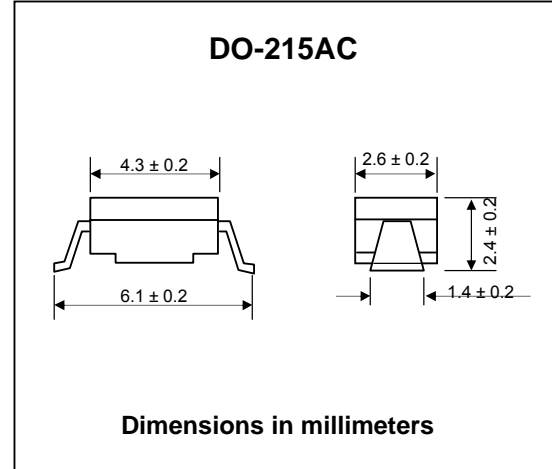

MECHANICAL DATA :

- * Case : DO-215AC Molded plastic
- * Epoxy : UL94V-O rate flame retardant
- * Polarity : Color band denotes cathode end
- * Mounting position : Any
- * Weight : 0.060 gram (Approximately)

MAXIMUM RATINGS AND ELECTRICAL CHARACTERISTICS

Rating at 25 °C ambient temperature unless otherwise specified. Single phase, half wave, 60 Hz, resistive or inductive load.
For capacitive load, derate current by 20%.

RATING	SYMBOL	GR15-G	GR20-G	UNIT
Maximum Recurrent Peak Reverse Voltage	V _{RRM}	1500	2000	V
Maximum RMS Voltage	V _{RMS}	1050	1400	V
Maximum DC Blocking Voltage	V _{DC}	1500	2000	V
Maximum Average Forward Current	I _{F(AV)}	0.5		A
Maximum Peak Forward Surge Current, 8.3ms Single half sine wave superimposed on rated load (JEDEC Method)	I _{FSM}	20		A
Maximum Forward Voltage at I _F = 0.1 A	V _F	2.0	2.6	V
Maximum DC Reverse Current Ta = 25 °C at Rated DC Blocking Voltage Ta = 100 °C	I _R	5.0		μA
	I _{R(H)}	50		μA
Maximum Reverse Recovery Time (Note 1)	T _{rr}	300	500	ns
Junction Temperature Range	T _J	- 65 to + 150		°C
Storage Temperature Range	T _{STG}	- 65 to + 150		°C

Note : (1) Reverse Recovery Test Conditions : I_F = 0.5 A, I_R = 1.0 A, I_{rr} = 0.25 A.

RATING AND CHARACTERISTIC CURVES (GR15-G ~ GR20-G)

FIG.1 - REVERSE RECOVERY TIME CHARACTERISTIC AND TEST CIRCUIT DIAGRAM

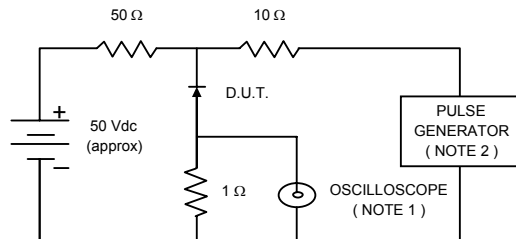

NOTES : 1. Rise Time = 7 ns max., Input Impedance = 1 megaohm, 22 pF.
 2. Rise time = 10 ns max., Source Impedance = 50 ohms.
 3. All Resistors = Non-inductive Types.

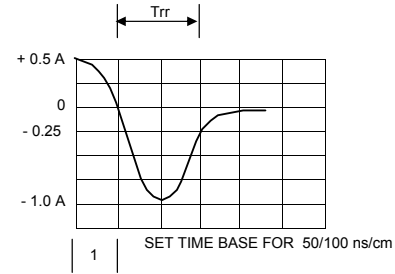

FIG.2 - DERATING CURVE FOR OUTPUT RECTIFIED CURRENT

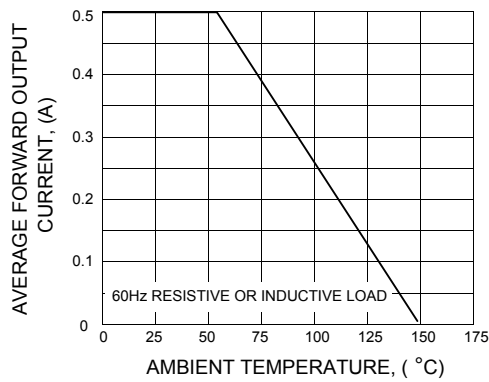

FIG.3 - MAXIMUM NON-REPETITIVE PEAK FORWARD SURGE CURRENT

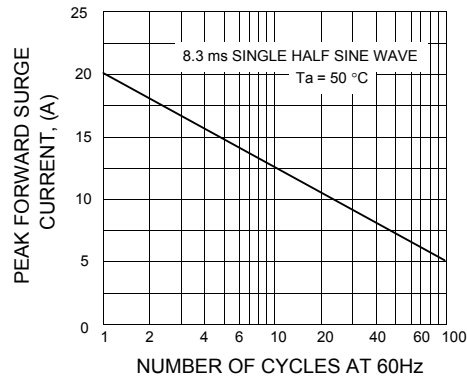

FIG.4 - TYPICAL FORWARD CHARACTERISTICS

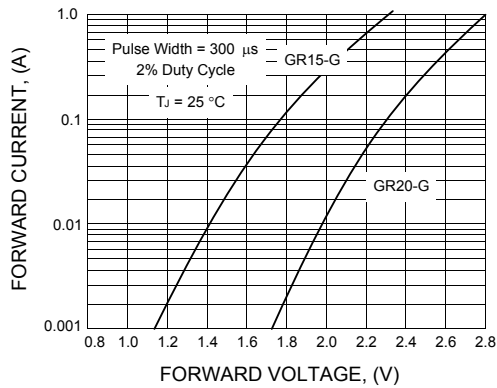

FIG.5 - TYPICAL REVERSE CHARACTERISTICS

