

UHF ASK/FSK Receiver

Description

The U3741BM is a multi-chip PLL receiver device supplied in an SO20 package. It has been specially developed for the demands of RF low-cost data transmission systems with low data rates from 1 kBaud to 10 kBaud (1 kBaud to 3.2 kBaud for FSK) in Manchester or Bi-phase code. The receiver is well suited to operate with the TEMIC PLL RF transmitter U2741B. Its main

applications are in the areas of telemetering, security technology and keyless-entry systems. It can be used in the frequency receiving range of $f_0 = 300$ MHz to 450 MHz for ASK or FSK data transmission. All the statements made below refer to 433.92-MHz and 315-MHz applications.

Features

- Minimal external circuitry requirements, no RF components on the PC board except adaptation to the receiver antenna
- High sensitivity, especially at low data rates
- Sensitivity reduction possible even while receiving
- Fully integrated VCO
- Low power consumption due to configurable self polling with a programmable timeframe check
- Supply voltage 4.5 V to 5.5 V, operating temperature range -40°C to 105°C
- Single-ended RF input for easy adaptation to $\lambda/4$ antenna or printed antenna on PCB
- Low-cost solution due to high integration level
- ESD protection according to MIL-STD. 883 (4KV HBM) except Pin POUT (2KV HBM)
- High image frequency suppression due to 1 MHz IF in conjunction with a SAW front-end filter. Up to 40 dB is thereby achievable with newer SAWs.
- Programmable output port for sensitivity selection or for controlling external periphery
- Communication to μC possible via a single, bi-directional data line
- Power management (polling) is also possible by means of a separate pin via the μC
- 2 different IF bandwidth versions are available (300 kHz and 600 kHz)

System Block Diagram

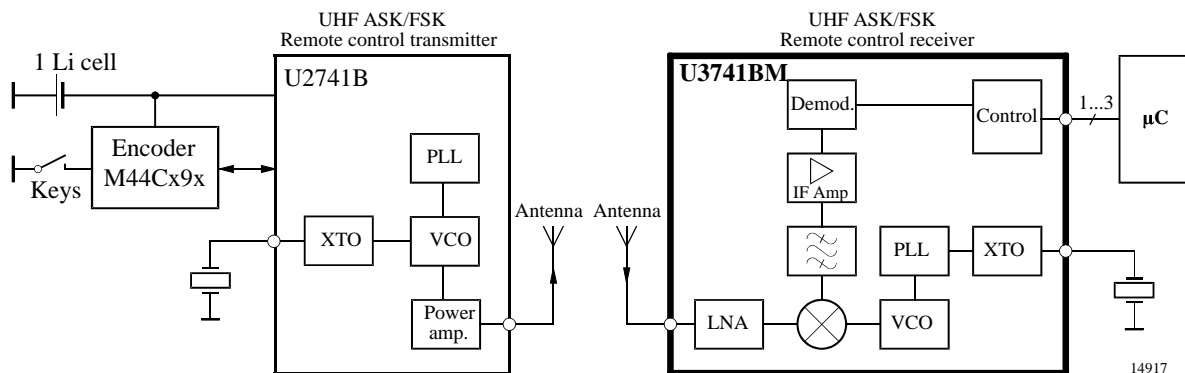

Figure 1. System block diagram

Ordering Information

Extended Type Number	Package	Remarks
U3741BM-M2FL	SO20	2: IF bandwidth of 300 kHz, tube
U3741BM-M2FLG3	SO20	2: IF bandwidth of 300 kHz, taped and reeled
U3741BM-M3FL	SO20	3: IF bandwidth of 600 kHz, tube
U3741BM-M3FLG3	SO20	3: IF bandwidth of 600 kHz, taped and reeled

Pin Description

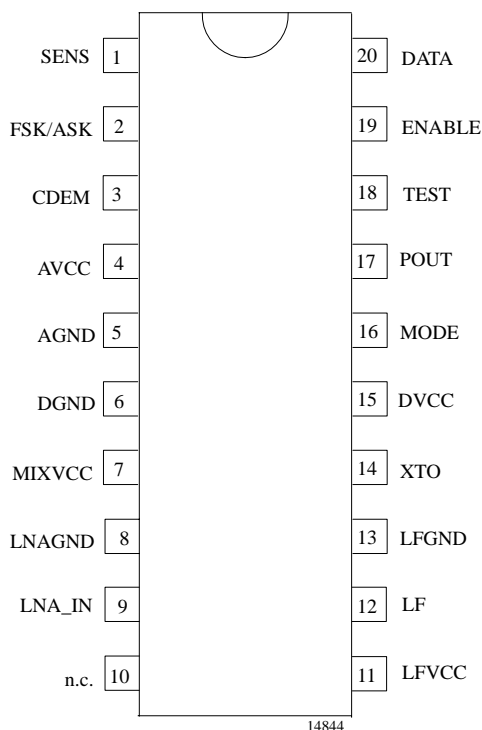

Figure 2. Pinning SO20

Pin	Symbol	Function
1	SENS	Sensitivity-control resistor
2	FSK/ASK	Selecting FSK/ASK Low: FSK, High: ASK
3	CDEM	Lower cut-off frequency data filter
4	AVCC	Analog power supply
5	AGND	Analog ground
6	DGND	Digital ground
7	MIXVCC	Power supply mixer
8	LNAGND	High-frequency ground LNA and mixer
9	LNA_IN	RF input
10	n.c.	Not connected
11	LFVCC	Power supply VCO
12	LF	Loop filter
13	LFGND	Ground VCO
14	XTO	Crystal oscillator
15	DVCC	Digital power supply
16	MODE	Selecting 433.92 MHz /315 MHz Low: 4.90625 MHz (USA) High: 6.76438 (Europe)
17	POUT	Programmable output port
18	TEST	Test pin, during operation at GND
19	ENABLE	Enables the polling mode Low: polling mode off (sleep mode) H: polling mode on (active mode)
20	DATA	Data output / configuration input

Block Diagram

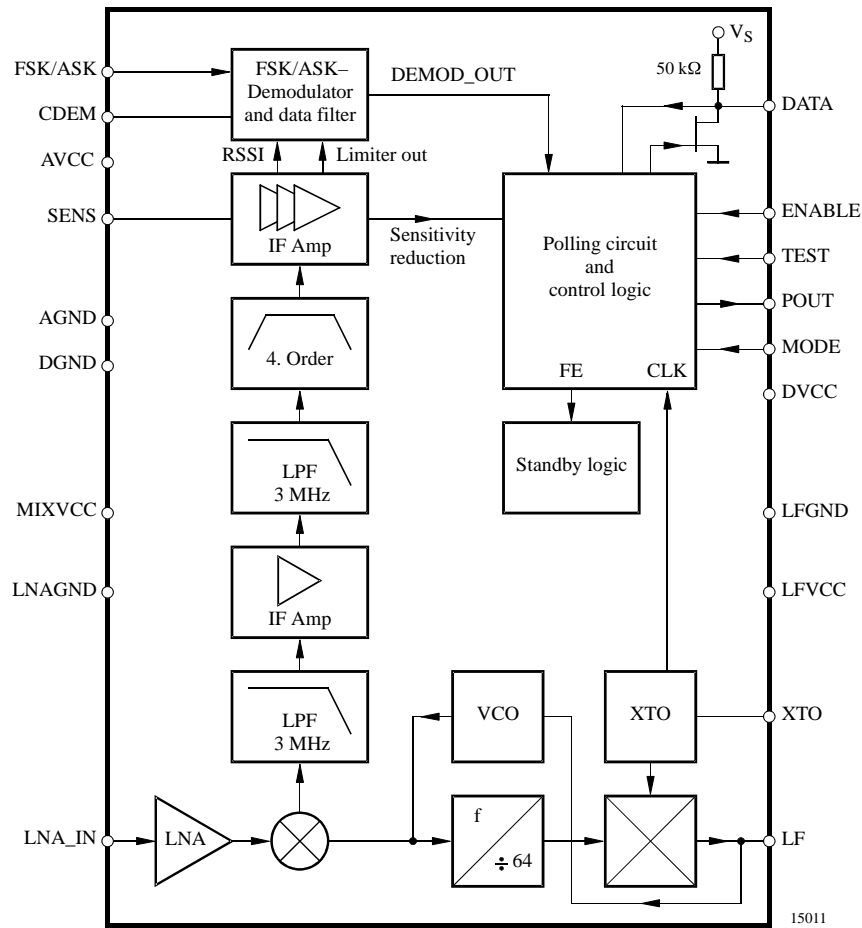

Figure 3. Block diagram

RF Front End

The RF front end of the receiver is a heterodyne configuration that converts the input signal into a 1-MHz IF signal. According to figure 3, the front end consists of an LNA (low noise amplifier) LO (local oscillator), a mixer and RF amplifier.

The LO generates the carrier frequency for the mixer via a PLL synthesizer. The XTO (crystal oscillator) generates the reference frequency f_{XTO} . The VCO (voltage-controlled oscillator) generates the drive voltage frequency f_{LO} for the mixer. f_{LO} is dependent on the voltage at Pin LF. f_{LO} is divided by factor 64. The divided frequency is compared to f_{XTO} by the phase frequency detector. The current output of the phase frequency detector is connected to a passive loop filter and thereby generates the control voltage V_{LF} for the VCO. By means

of that configuration V_{LF} is controlled in a way that $f_{LO}/64$ is equal to f_{XTO} . If f_{LO} is determined, f_{XTO} can be calculated using the following formula:

$$f_{XTO} = f_{LO}/64$$

The XTO is a one-pin oscillator that operates at the series resonance of the quartz crystal. According to figure 4, the crystal should be connected to GND via a capacitor CL. The value of that capacitor is recommended by the crystal supplier. The value of CL should be optimized for the individual board layout to achieve the exact value of f_{XTO} and hereby of f_{LO} . When designing the system in terms of receiving bandwidth, the accuracy of the crystal and the XTO must be considered.

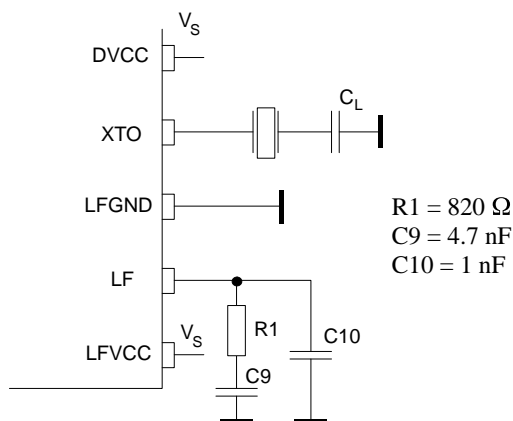

Figure 4. PLL peripherals

The passive loop filter connected to Pin LF is designed for a loop bandwidth of $B_{Loop} = 100$ kHz. This value for B_{Loop} exhibits the best possible noise performance of the LO. Figure 4 shows the appropriate loop filter components to achieve the desired loop bandwidth. If the filter components are changed for any reason please notify that the maximum capacitive load at Pin LF is limited. If the capacitive load is exceeded, a bitcheck may no longer be possible since f_{LO} cannot settle in time before the bitcheck starts to evaluate the incoming data stream. Self polling does therefore also not work in that case.

f_{LO} is determined by the RF input frequency f_{RF} and the IF frequency f_{IF} using the following formula:

$$f_{LO} = f_{RF} - f_{IF}$$

To determine f_{LO} , the construction of the IF filter must be considered at this point. The nominal IF frequency is $f_{IF} = 1$ MHz. To achieve a good accuracy of the filter's corner frequencies, the filter is tuned by the crystal frequency f_{XTO} . This means that there is a fixed relation between f_{IF} and f_{LO} . This relation is dependent on the logic level at pin mode. This is described by the following formulas:

$$\text{MODE} = 0 \text{ (USA)} \quad f_{IF} = \frac{f_{LO}}{314}$$

$$\text{MODE} = 1 \text{ (Europe)} \quad f_{IF} = \frac{f_{LO}}{432.92}$$

The relation is designed to achieve the nominal IF frequency of $f_{IF} = 1$ MHz for most applications. For applications where $f_{RF} = 315$ MHz, MODE must be set to '0'. In the case of $f_{RF} = 433.92$ MHz, MODE must be set to '1'. For other RF frequencies, f_{IF} is not equal to 1 MHz. f_{IF} is then dependent on the logical level at Pin MODE and on f_{RF} . Table 1 summarizes the different conditions.

The RF input either from an antenna or from a generator must be transformed to the RF input Pin LNA_IN. The input impedance of that pin is provided in the electrical parameters. The parasitic board inductances and capacitances also influence the input matching. The RF receiver U3741BM exhibits its highest sensitivity at the best signal-to-noise ratio in the LNA. Hence, noise matching is the best choice for designing the transformation network.

A good practice when designing the network is to start with power matching. From that starting point, the values of the components can be varied to some extent to achieve the best sensitivity.

If a SAW is implemented into the input network a mirror frequency suppression of $\Delta P_{Ref} = 40$ dB can be achieved. There are SAWs available that exhibit a notch at $\Delta f = 2$ MHz. These SAWs work best for an intermediate frequency of IF = 1 MHz. The selectivity of the receiver is also improved by using a SAW. In typical automotive applications, a SAW is used.

Figure 5 shows a typical input matching network, for $f_{RF} = 315$ MHz and $f_{RF} = 433.92$ MHz using a SAW. Figure 6 illustrates an according input matching to 50 Ω without a SAW. The input matching networks shown in figure 6 are the reference networks for the parameters given in the electrical characteristics.

Table 1. Calculation of LO and IF frequency

Conditions	Local Oscillator Frequency	Intermediate Frequency
$f_{RF} = 315$ MHz, MODE = 0	$f_{LO} = 314$ MHz	$f_{IF} = 1$ MHz
$f_{RF} = 433.92$ MHz, MODE = 1	$f_{LO} = 432.92$ MHz	$f_{IF} = 1$ MHz
$300 \text{ MHz} < f_{RF} < 365 \text{ MHz}$, MODE = 0	$f_{LO} = \frac{f_{RF}}{1 + \frac{1}{314}}$	$f_{LO} = \frac{f_{RF}}{314}$
$365 \text{ MHz} < f_{RF} < 450 \text{ MHz}$, MODE = 1	$f_{LO} = \frac{f_{RF}}{1 + \frac{1}{432.92}}$	$f_{LO} = \frac{f_{RF}}{432.92}$

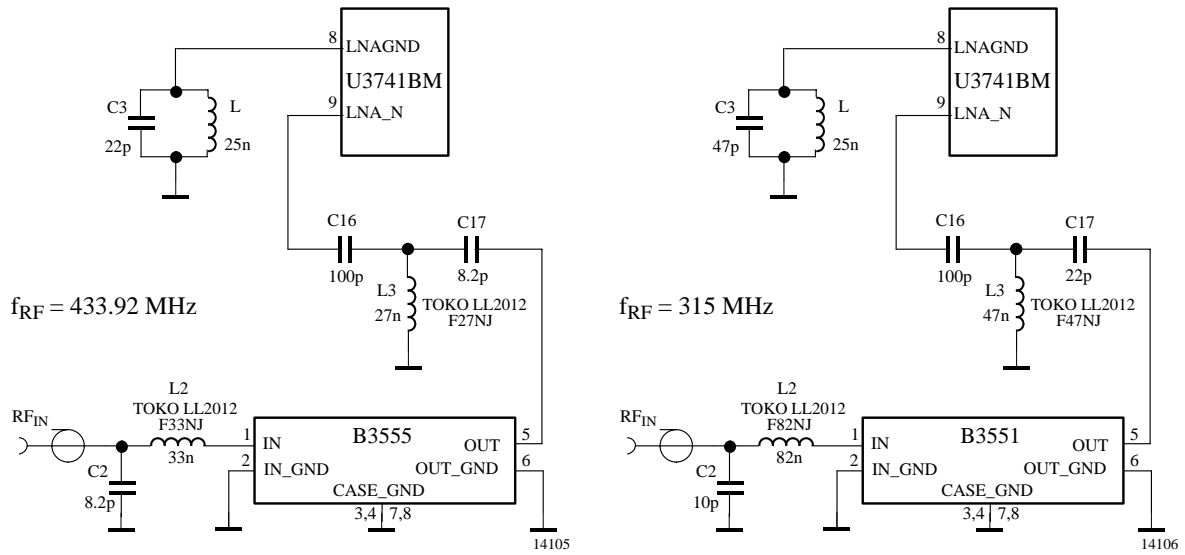

Figure 5. Input matching network with SAW filter

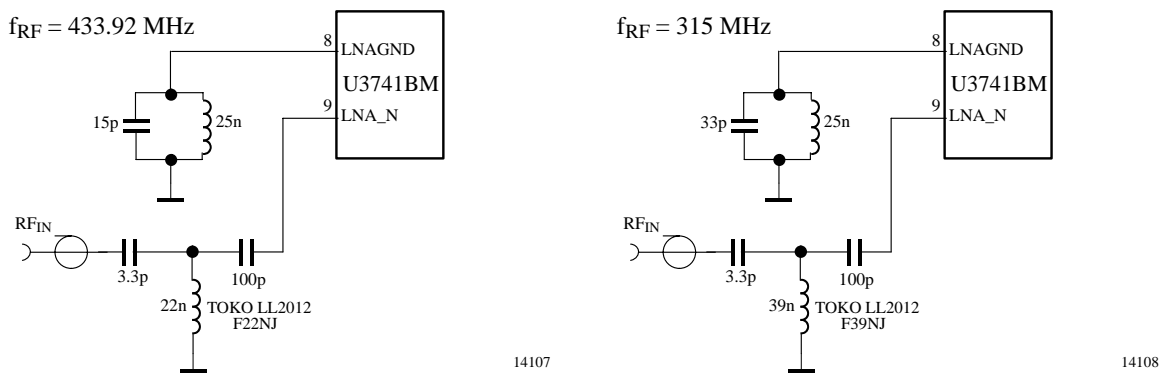

Figure 6. Input matching network without SAW filter

Please notify that for all coupling conditions (see figures 5 and 6), the bond wire inductivity of the LNA ground is compensated. C3 forms a series resonance circuit together with the bond wire. L = 25 nH is a feed inductor to establish a DC path. Its value is not critical but must be large enough not to detune the series resonance circuit. For cost reduction this inductor can be easily printed on the PCB. This configuration improves the sensitivity of the receiver by about 1 dB to 2 dB.

Analog Signal Processing

IF Amplifier

The signals coming from the RF front end are filtered by the fully integrated 4th-order IF filter. The IF center frequency is $f_{IF} = 1$ MHz for applications where

$f_{RF} = 315$ MHz or $f_{RF} = 433.92$ MHz is used. For other RF input frequencies refer to table 1 to determine the center frequency.

The U3741BM is available with 2 different IF bandwidths. U3741BM-M2, the version with $B_{IF} = 300$ kHz, is well suited for ASK systems where the TEMIC PLL transmitter U2741B is used. The receiver U3741BM - M3 employs an IF bandwidth of $f_{IF} = 600$ kHz. This version can be used together with the U2741B in FSK and ASK mode. If used in ASK applications, it allows higher tolerances for the receiver and PLL transmitter crystals. SAW transmitters exhibit much higher transmit frequency tolerances compared to PLL transmitters. Generally, it is necessary to use $B_{IF} = 600$ kHz together with such transmitters.

RSSI Amplifier

The subsequent RSSI amplifier enhances the output signal of the IF amplifier before it is fed into the demodulator. The dynamic range of this amplifier is $DR_{RSSI} = 60$ dB. If the RSSI amplifier is operated within its linear range, the best S/N ratio is maintained in ASK mode. If the dynamic range is exceeded by the transmitter signal, the S/N ratio is defined by the ratio of the maximum RSSI output voltage and the RSSI output voltage due to a disturber. The dynamic range of the RSSI amplifier is exceeded if the RF input signal is about 60 dB higher compared to the RF input signal at full sensitivity.

In FSK mode the S/N ratio is not affected by the dynamic range of the RSSI amplifier.

The output voltage of the RSSI amplifier is internally compared to a threshold voltage V_{Th_red} . V_{Th_red} is determined by the value of the external resistor R_{Sense} . R_{Sense} is connected between Pin Sense and GND or V_S . The output of the comparator is fed into the digital control logic. By this means it is possible to operate the receiver at a lower sensitivity.

If R_{Sense} is connected to V_S , the receiver operates at a lower sensitivity. The reduced sensitivity is defined by the value of R_{Sense} , the maximum sensitivity by the signal-to-noise ratio of the LNA input. The reduced sensitivity is dependent on the signal strength at the output of the RSSI amplifier.

Since different RF input networks may exhibit slightly different values for the LNA gain the sensitivity values given in the electrical characteristics refer to a specific input matching. This matching is illustrated in figure 6 and exhibits the best possible sensitivity.

R_{Sense} can be connected to V_S or GND via a μC or by the digital output port POUT of the U3741BM receiver IC. The receiver can be switched from full sensitivity to reduced sensitivity or vice versa at any time. In polling mode the receiver will not wake up if the RF input signal does not exceed the selected sensitivity. If the receiver is already active, the data stream at Pin DATA will disappear when the input signal is lower than defined by the reduced sensitivity. Instead of the data stream, the pattern according to figure 7 is issued at Pin DATA to indicate that the receiver is still active.

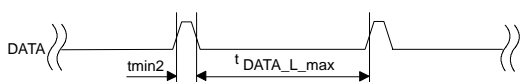

Figure 7. Steady L state limited DATA output pattern

FSK/ASK Demodulator and Data Filter

The signal coming from the RSSI amplifier is converted into the raw data signal by the ASK/FSK demodulator. The operating mode of the demodulator is set via Pin ASK/FSK. Logic 'L' sets the demodulator to FSK, applying 'H' sets it into ASK mode.

In ASK mode an automatic threshold control circuit (ATC) is employed to set the detection reference voltage to a value where a good signal-to-noise ratio is achieved. This circuit also implies the effective suppression of any kind of inband noise signals or competing transmitters. If the S/N ratio exceeds 10 dB, the data signal can be detected properly.

The FSK demodulator is intended to be used for an FSK deviation of $\Delta f \geq 20$ kHz. Lower values may be used but the sensitivity of the receiver is reduced in that condition. The minimum usable deviation is dependent on the selected baudrate. In ASK mode, only BR_Range0 and BR_Range1 are available. In FSK mode, the data signal can be detected if the S/N Ratio exceeds 2 dB.

The output signal of the demodulator is filtered by the data filter before it is fed into the digital signal processing circuit. The data filter improves the S/N ratio as its passband can be adopted to the characteristics of the data signal. The data filter consists of a 1st-order highpass and a 1st-order lowpass filter.

The highpass filter cut-off frequency is defined by an external capacitor connected to Pin CDEM. The cut-off frequency of the highpass filter is defined by the following formula:

$$f_{cu_DF} = \frac{1}{2 \times \pi \times 30 \text{ k}\Omega \times CDEM}$$

In self-polling mode, the data filter must settle very rapidly to achieve a low current consumption. Therefore, CDEM cannot be increased to very high values if self-polling is used. On the other hand CDEM must be large enough to meet the data filter requirements according to the data signal. Recommended values for CDEM are given in the electrical characteristics. The values are slightly different for ASK and FSK mode.

The cut-off frequency of the lowpass filter is defined by the selected baudrate range (BR_Range). BR_Range is defined in the OPMODE register (refer to chapter 'Configuration of the Receiver'). BR_Range must be set in accordance to the used baudrate.

The U3741BM is designed to operate with data coding where the DC level of the data signal is 50%. This is valid for Manchester and Bi-phase coding. If other modulation schemes are used, the DC level should always remain within the range of $V_{DC_min} = 33\%$ and $V_{DC_max} = 66\%$. The sensitivity may be reduced by up to 1.5 dB in that condition.

Each BR_Range is also defined by a minimum and a maximum edge-to-edge time (t_{ee_sig}). These limits are defined in the electrical characteristics. They should not be exceeded to maintain full sensitivity of the receiver.

Receiving Characteristics

The RF receiver U3741BM can be operated with and without a SAW front end filter. In a typical automotive application, a SAW filter is used to achieve better selectivity. The selectivity with and without a SAW front end filter is illustrated in figure 8. This example relates to ASK mode and the 300-kHz bandwidth version of the U3741BM. FSK mode and the 600-kHz version of the receiver exhibit similar behavior. Note that the mirror frequency is reduced by 40 dB. The plots are printed relatively to the maximum sensitivity. If a SAW filter is used, an insertion loss of about 4 dB must be considered.

When designing the system in terms of receiving bandwidth, the LO deviation must be considered as it also determines the IF center frequency. The total LO deviation is calculated to be the sum of the deviation of the crystal and the XTO deviation of the U3741BM. Low-cost crystals are specified to be within ± 100 ppm. The XTO deviation of the U3741BM is an additional deviation due to the XTO circuit. This deviation is specified to be ± 30 ppm. If a crystal of ± 100 ppm is used, the total deviation is ± 130 ppm in that case. Note that the receiving bandwidth and the IF-filter bandwidth are equivalent in ASK mode but not in FSK mode.

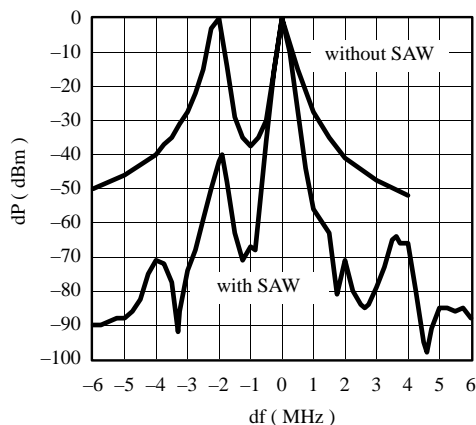

Figure 8. Receiving frequency response

Polling Circuit and Control logic

The receiver is designed to consume less than 1 mA while being sensitive to signals from a corresponding transmitter. This is achieved via the polling circuit. This circuit enables the signal path periodically for a short time. During this time the bitcheck logic verifies the presence of a valid transmitter signal. Only if a valid signal is detected the receiver remains active and transfers the data to the connected μC . If there is no valid signal present the receiver is in sleep mode most of the time resulting in low current consumption. This condition is called polling mode. A connected μC is disabled during that time.

All relevant parameters of the polling logic can be configured by the connected μC . This flexibility enables the user to meet the specifications in terms of current consumption, system response time, data rate etc.

Regarding the number of connection wires to the μC , the receiver is very flexible. It can be either operated by a single bi-directional line to save ports to the connected μC . Or it can be operated by up to three uni-directional ports.

Basic Clock Cycle of the Digital Circuitry

The complete timing of the digital circuitry and the analog filtering is derived from one clock. According to figure 9, this clock cycle T_{Clk} is derived from the crystal oscillator (XTO) in combination with a divider. The division factor is controlled by the logical state at Pin MODE. According to chapter 'RF Front End', the frequency of the crystal oscillator (f_{XTO}) is defined by the RF input signal (f_{RFin}) which also defines the operating frequency of the local oscillator (f_{LO}).

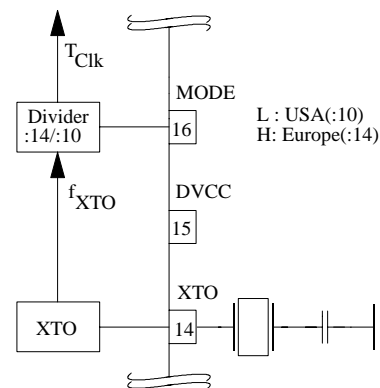

Figure 9. Generation of the basic clock cycle

Pin MODE can now be set in accordance with the desired clock cycle T_{Clk} . T_{Clk} controls the following application-relevant parameters:

- Timing of the polling circuit including bitcheck
- Timing of the analog and digital signal processing
- Timing of the register programming
- Frequency of the reset marker
- IF filter center frequency (f_{IF0})

Most applications are dominated by two transmission frequencies: $f_{Send} = 315$ MHz is mainly used in USA, $f_{Send} = 433.92$ MHz in Europe. In order to ease the usage of all T_{Clk} -dependent parameters on this electrical characteristics display three conditions for each parameter.

- Application USA
($f_{XTO} = 4.90625$ MHz, MODE = L, $T_{Clk} = 2.0383$ μ s)
- Application Europe
($f_{XTO} = 6.76438$ MHz, MODE = H, $T_{Clk} = 2.0697$ μ s)
- Other applications
(T_{Clk} is dependent on f_{XTO} and on the logical state of Pin MODE. The electrical characteristic is given as a function of T_{Clk}).

The clock cycle of some function blocks depends on the selected baud rate range (BR_Range) which is defined in the OPMODE register. This clock cycle T_{XClk} is defined by the following formulas for further reference:

$$\begin{aligned} \text{BR_Range} = \text{BR_Range0: } T_{XClk} &= 8 \times T_{Clk} \\ \text{BR_Range1: } T_{XClk} &= 4 \times T_{Clk} \\ \text{BR_Range2: } T_{XClk} &= 2 \times T_{Clk} \\ \text{BR_Range3: } T_{XClk} &= 1 \times T_{Clk} \end{aligned}$$

Polling Mode

According to figure 5 the receiver stays in polling mode in a continuous cycle of three different modes. In sleep mode the signal processing circuitry is disabled for the time period T_{Sleep} while consuming low current of $I_S = I_{Soff}$. During the start-up period, $T_{Startup}$, all signal processing circuits are enabled and settled. In the following bitcheck mode, the incoming data stream is analyzed bit by bit contra a valid transmitter signal. If no valid signal is present, the receiver is set back to sleep mode after the period $T_{Bitcheck}$. This period varies check by check as it is a statistical process. An average value for $T_{Bitcheck}$ is given in the electrical characteristics. During $T_{Startup}$ and $T_{Bitcheck}$ the current consumption is $I_S = I_{Son}$. The average current consumption in polling mode is

dependent on the duty cycle of the active mode and can be calculated as:

$$I_{Spoll} = \frac{I_{Soff} \times T_{Sleep} + I_{Son} \times (T_{Startup} + T_{Bitcheck})}{T_{Sleep} + T_{Startup} + T_{Bitcheck}}$$

During T_{Sleep} and $T_{Startup}$ the receiver is not sensitive to a transmitter signal. To guarantee the reception of a transmitted command the transmitter must start the telegram with an adequate preburst. The required length of the preburst is dependent on the polling parameters T_{Sleep} , $T_{Startup}$, $T_{Bitcheck}$ and the startup time of a connected μ C ($T_{Start,\mu C}$). $T_{Bitcheck}$ thus depends on the actual bitrate and the number of bits ($N_{Bitcheck}$) to be tested.

The following formula indicates how to calculate the preburst length.

$$T_{Purburst} \geq T_{Sleep} + T_{Startup} + T_{Bitcheck} + T_{Start,\mu C}$$

Sleep Mode

The length of period T_{Sleep} is defined by the 5-bit word Sleep of the OPMODE register, the extension factor X_{Sleep} , according to table 10, and the basic clock cycle T_{Clk} . It is calculated to be:

$$T_{Sleep} = \text{Sleep} \times X_{Sleep} \times 1024 \times T_{Clk}$$

In US- and European applications, the maximum value of T_{Sleep} is about 60 ms if X_{Sleep} is set to 1. The time resolution is about 2 ms in that case. The sleep time can be extended to almost half a second by setting X_{Sleep} to 8. X_{Sleep} can be set to 8 by bit $X_{SleepStd}$ or by bit $X_{SleepTemp}$ resulting in a different mode of action as described below:

$X_{SleepStd} = 1$ implies the standard extension factor. The sleep time is always extended.

$X_{SleepTemp} = 1$ implies the temporary extension factor. The extended sleep time is used as long as every bitcheck is OK. If the bitcheck fails once, this bit is set back to 0 automatically resulting in a regular sleep time. This functionality can be used to save current in presence of a modulated disturber similar to an expected transmitter signal. The connected μ C is activated rarely in that condition. If the disturber disappears, the receiver switches back to regular polling and is again sensitive to appropriate transmitter signals.

According to table 7, the highest register value of Sleep sets the receiver into a permanent sleep condition. The receiver remains in that condition until another value for Sleep is programmed into the OPMODE register. This function is desirable where several devices share a single data line.

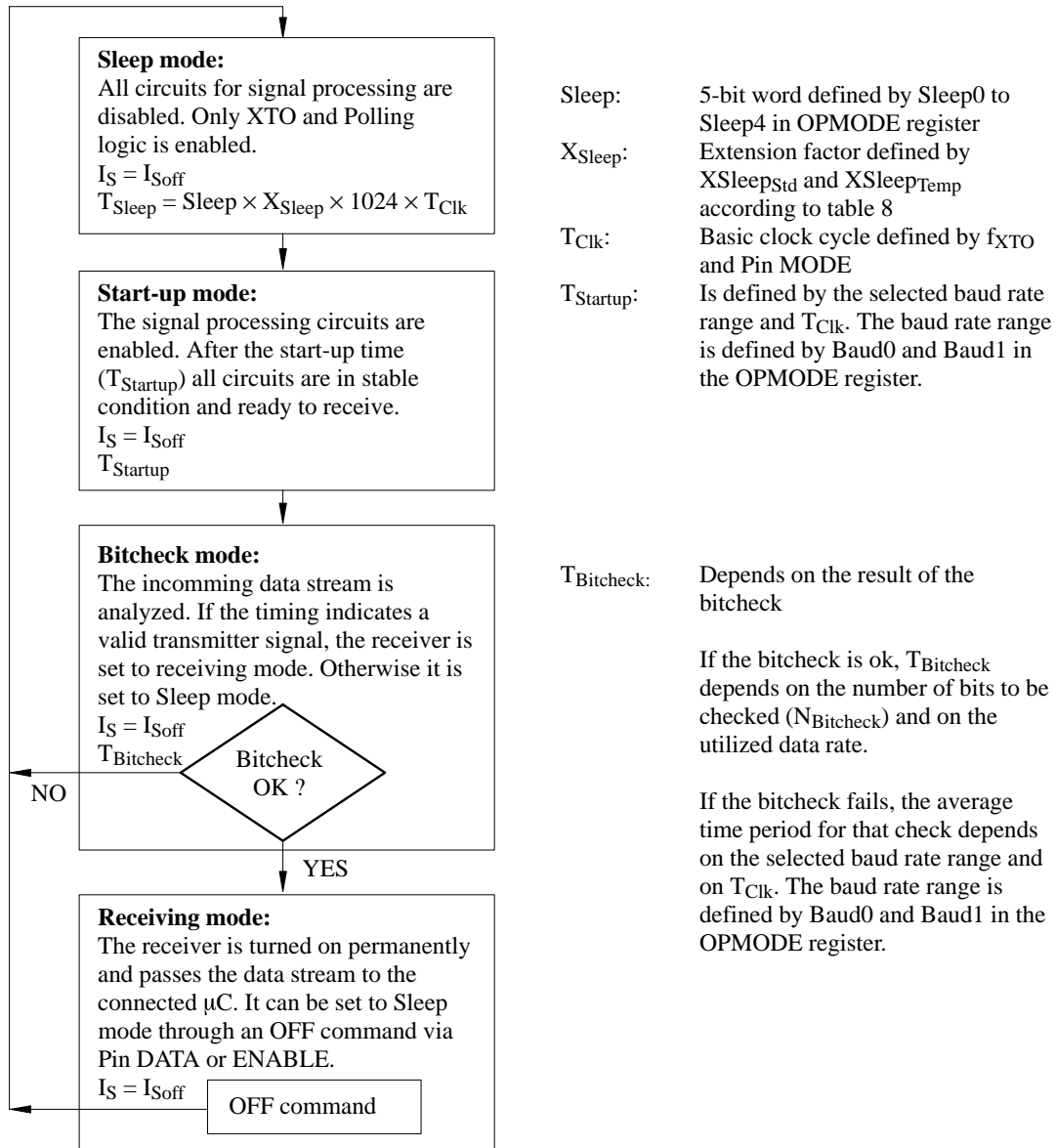

Figure 10. Polling mode flow chart

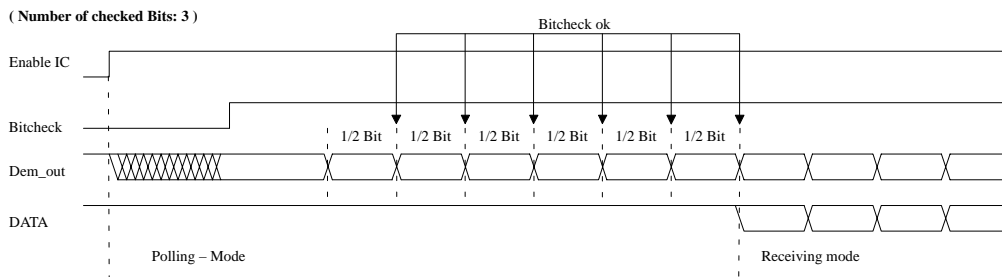

Figure 11. Timing diagram for complete successful bitcheck

Bitcheck Mode

In bitcheck mode the incoming data stream is examined to distinguish between a valid signal from a corresponding transmitter and signals due to noise. This is done by subsequent time frame checks where the distances between 2 signal edges are continuously compared to a programmable time window. The maximum count of this edge-to-edge tests before the receiver switches to receiving mode is also programmable.

Configuring the bitcheck

Assuming a modulation scheme that contains 2 edges per bit, two time frame checks are verifying one bit. This is valid for Manchester, Bi-phase and most other modulation schemes. The maximum count of bits to be checked can be set to 0, 3, 6 or 9 bits via the variable N_{Bitcheck} in the OPMODE register. This implies 0, 6, 12 and 18 edge to edge checks respectively. If N_{Bitcheck} is set to a higher value, the receiver is less likely to switch to receiving mode due to noise. In the presence of a valid transmitter signal, the bitcheck takes less time if N_{Bitcheck} is set to a lower value. In polling mode, the bitcheck time is not dependent on N_{Bitcheck} . Figure 11 shows an example where 3 bits are tested successfully and the data signal is transferred to Pin DATA.

According to figure 12, the time window for the bitcheck is defined by two separate time limits. If the edge-to-edge time t_{ee} is in between the lower bitcheck limit $T_{\text{Lim_min}}$ and the upper bitcheck limit $T_{\text{Lim_max}}$, the check will be continued. If t_{ee} is smaller than $T_{\text{Lim_min}}$ or t_{ee} exceeds $T_{\text{Lim_max}}$, the bitcheck will be terminated and the receiver switches to sleep mode.

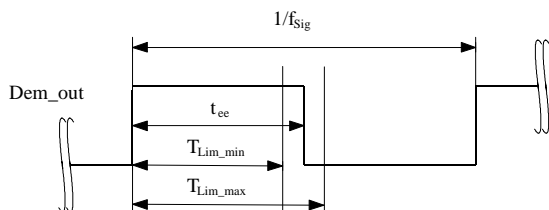

Figure 12. Valid time window for bitcheck

For best noise immunity it is recommended to use a low span between $T_{\text{Lim_min}}$ and $T_{\text{Lim_max}}$. This is achieved using a fixed frequency at a 50% duty cycle for the transmitter preburst. A ‘11111...’ or a ‘10101...’ sequence in Manchester or Bi-phase is a good choice concerning that advice. A good compromise between receiver sensitivity and susceptibility to noise is a time window of $\pm 25\%$ regarding the expected edge-to-edge time t_{ee} . Using pre-burst patterns that contain various edge-to-edge time periods, the bitcheck limits must be programmed according to the required span.

The bitcheck limits are determined by means of the formula below.

$$T_{\text{Lim_min}} = \text{Lim_min} \times T_{\text{XClk}}$$

$$T_{\text{Lim_max}} = (\text{Lim_max} - 1) \times T_{\text{XClk}}$$

Lim_min and Lim_max are defined by a 5-bit word each within the LIMIT register.

Using above formulas Lim_min and Lim_max can be determined according to the required $T_{\text{Lim_min}}$, $T_{\text{Lim_max}}$ and T_{XClk} . The time resolution in defining $T_{\text{Lim_min}}$ and $T_{\text{Lim_max}}$ is T_{XClk} . The minimum edge-to-edge time t_{ee} ($t_{\text{DATA_L_min}}$, $t_{\text{DATA_H_min}}$) is defined according to the chapter ‘Receiving Mode’. Due to this, the lower limit should be set to $\text{Lim_min} \geq 10$. The maximum value of the upper limit is $\text{Lim_max} = 63$.

Figures 13, 14 and 15 are illustrating the bitcheck for the default bitcheck limits $\text{Lim_min} = 14$ and $\text{Lim_max} = 24$. When the IC is enabled, the signal processing circuits are enabled during T_{Startup} . The output of the ASK/ FSK demodulator (Dem_out) is undefined during that period. When the bitcheck becomes active, the bitcheck counter is clocked with the cycle T_{XClk} .

Figure 13 shows how the bitcheck proceeds if the bitcheck counter value CV_Lim is within the limits defined by Lim_min and Lim_max at the occurrence of a signal edge. In figure 14 the bitcheck fails as the value CV_Lim is lower than the limit Lim_min . The bitcheck also fails if CV_Lim reaches Lim_max . This is illustrated in figure 15.

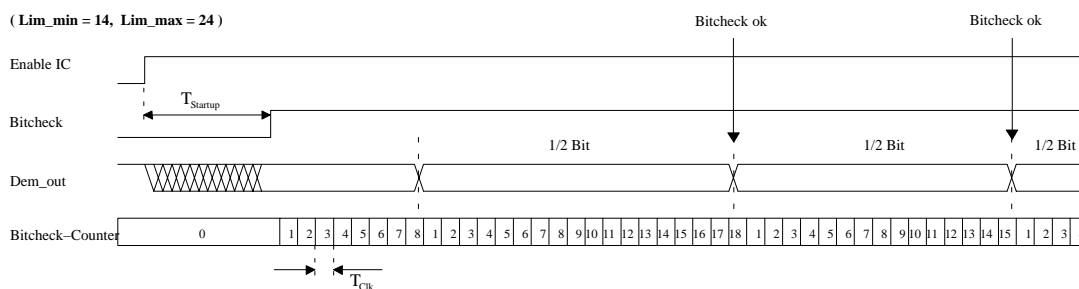

Figure 13. Timing diagram during bitcheck

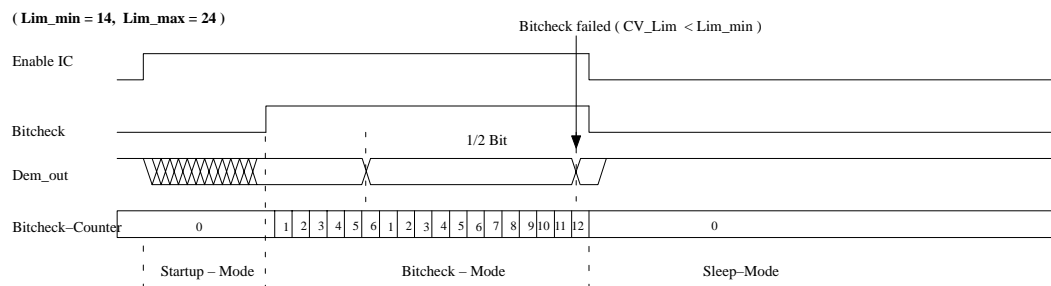

Figure 14. Timing diagram for failed bitcheck (condition: CV_Lim < Lim_min)

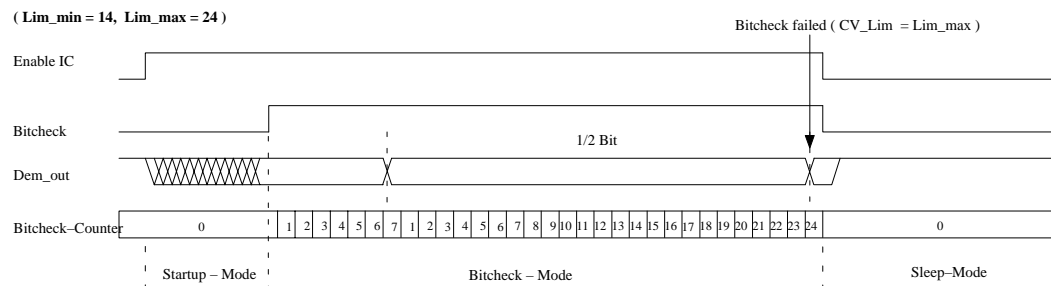

Figure 15. Timing diagram for failed bitcheck (condition: CV_Lim < Lim_max)

Duration of the Bitcheck

If no transmitter signal is present during the bitcheck, the output of the ASK/FSK demodulator delivers random signals. The bitcheck is a statistical process and T_{Bitcheck} varies for each check. Therefore, an average value for T_{Bitcheck} is given in the electrical characteristics. T_{Bitcheck} depends on the selected baudrate range and on T_{Clk} . A higher baudrate range causes a lower value for T_{Bitcheck} resulting in a lower current consumption for polling mode.

In the presence of a valid transmitter signal, T_{Bitcheck} is dependant on the frequency of that signal, f_{Sig} and the count of the checked bits, N_{Bitcheck} . A higher value for N_{Bitcheck} thereby results in a longer period for T_{Bitcheck} requiring a higher value for the transmitter pre-burst T_{Preburst} .

Receiving Mode

If the bitcheck is successful for all bits specified by N_{Bitcheck} , the receiver switches to receiving mode. According to figure 11, the internal data signal is switched to Pin DATA in that case. A connected μC can be woken up by the negative edge at Pin DATA. The receiver stays in that condition until it is switched back to polling mode explicitly.

Digital Signal Processing

The data from the ASK/FSK demodulator (Dem_out) is digitally processed in different ways and as a result converted into the output signal data. This processing depends on the selected baudrate range (BR_Range). Figure 16 illustrates how Dem_out is synchronized by the extended clock cycle T_{XClk} . This clock is also used for the Bitcheck counter. Data can change its state only after T_{XClk} elapsed. The edge-to-edge time period t_{ee} of the Data signal as a result is always an integral multiple of T_{XClk} .

The minimum time period between two edges of the data signal is limited to $t_{\text{ee}} \geq T_{\text{DATA_min}}$. This implies an efficient suppression of spikes at the DATA output. At the same time it limits the maximum frequency of edges at DATA. This eases the interrupt handling of a connected μC . $T_{\text{DATA_min}}$ is to some extent affected by the preceding edge-to-edge time interval t_{ee} as illustrated in figure 17. If t_{ee} is in between the specified bitcheck limits, the following level is frozen for the time period $T_{\text{DATA_min}} = t_{\text{min1}}$, in case of t_{ee} being outside that bitcheck limits $T_{\text{DATA_min}} = t_{\text{min2}}$ is the relevant stable time period.

The maximum time period for DATA to be Low is limited to $T_{\text{DATA_L_max}}$. This function is employed to ensure a finite response time in programming or switching off the receiver via Pin DATA. $T_{\text{DATA_L_max}}$ is thereby longer than the maximum time period indicated by the transmitter data stream. Figure 18 gives an example where Dem_out remains Low after the receiver is in receiving mode.

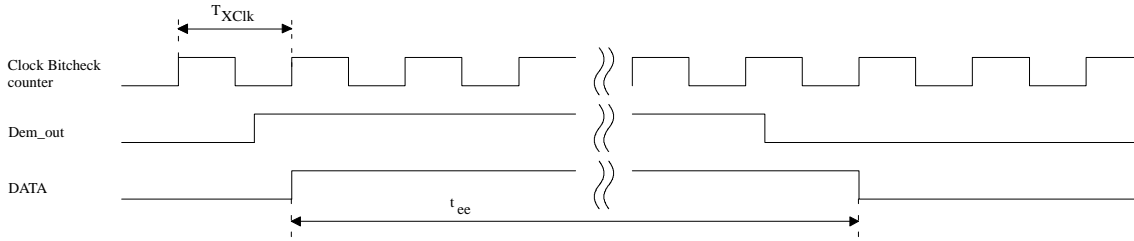

Figure 16. Synchronization of the demodulator output

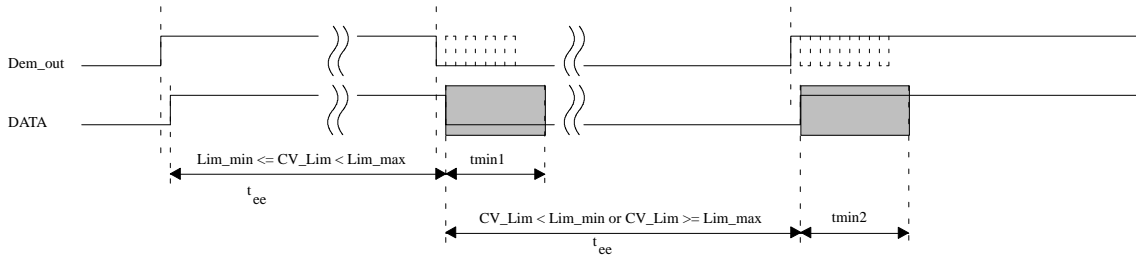

Figure 17. Debouncing of the demodulator output

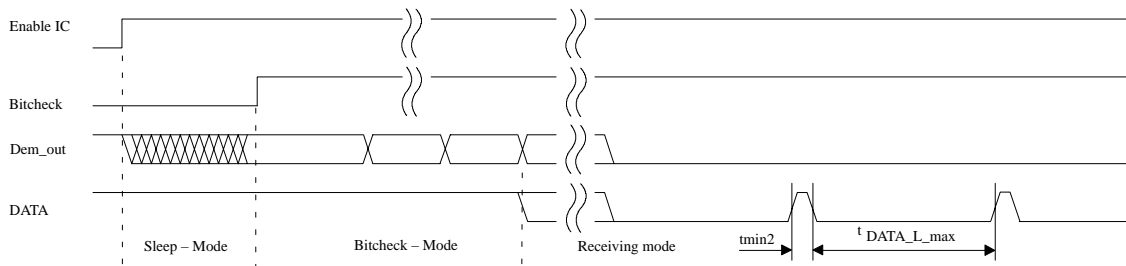

Figure 18. Steady L state limited DATA output pattern after transmission

After the end of a data transmission the receiver remains active and random noise pulses appear at Pin DATA. The edge-to-edge time period t_{ee} of the majority of these noise pulses is equal or slightly higher than T_{DATA_min} .

Switching the Receiver Back to Sleep Mode

The receiver can be set back to polling mode via Pin DATA or via Pin ENABLE.

When using Pin DATA, this pin must be pulled to Low for the period t_1 by the connected μC . Figure 19 illustrates the timing of the OFF command (see also figure 23). The minimum value of t_1 depends on BR_Range. The maximum value for t_1 is not limited but it is recommended not to exceed the specified value to prevent erasing the reset marker. This item is explained in more detail in the chapter 'Configuration of the Receiver'. Setting the receiver to sleep mode via DATA

is achieved by programming bit 1 of the OPMODE register to be '1'. Only one sync pulse (t_3) is issued.

The duration of the OFF command is determined by the sum of t_1 , t_2 and t_{10} . After the OFF command initially the sleep time T_{Sleep} elapses. Note that the capacitive load at Pin DATA is limited. The resulting time constant τ together with an optional external pull-up resistor may not be exceeded to ensure proper operation.

If the receiver is set to polling mode via Pin ENABLE, a 'L' pulse (T_{Doze}) must be issued at that pin. Figure 20 illustrates the timing of that command. After the positive edge of this pulse the sleep time T_{Sleep} elapses. The receiver remains in sleep mode as long as ENABLE is held to 'L'. If the receiver is polled exclusively by a μC , T_{Sleep} can be programmed to 0 to enable a instantaneous response time. This command is the faster option than via Pin DATA at the cost of an additional connection to the μC .

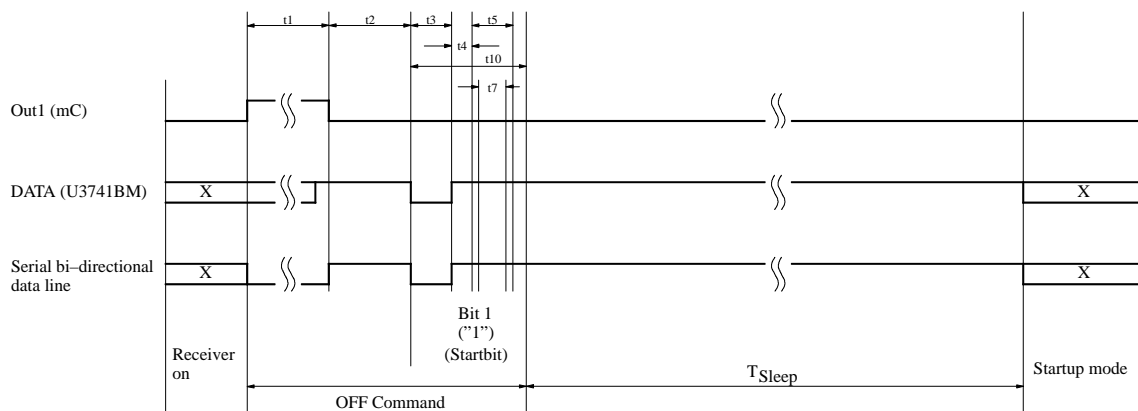

Figure 19. Timing diagram of the OFF-command via Pin DATA

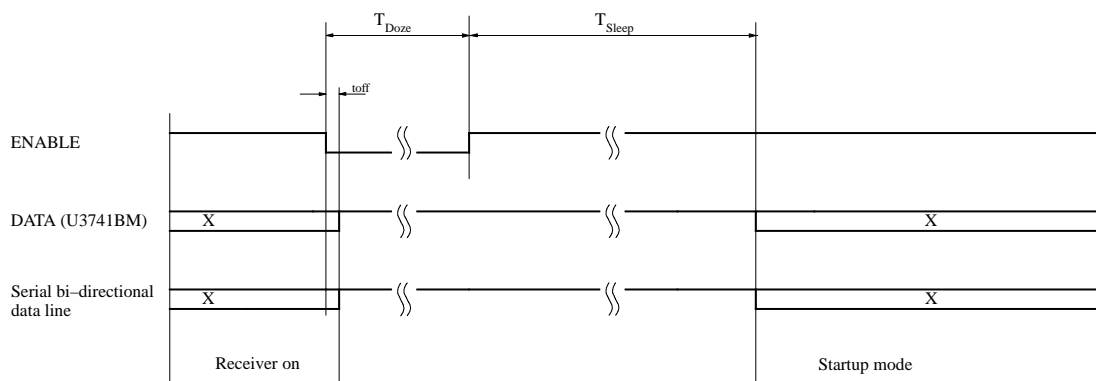

Figure 20. Timing diagram of the OFF-command via Pin ENABLE

Configuration of the Receiver

The U3741BM receiver is configured via two 12-bit RAM registers called OPMODE and LIMIT. The registers can be programmed by means of the bi-directional DATA port. If the register contents have changed due to a voltage drop, this condition is indicated by a certain output pattern called reset marker (RM). The receiver must be reprogrammed in that case. After a power-on reset (POR), the registers are set to default mode. If the receiver is operated in default mode, there is no need to program the registers.

Table 3 shows the structure of the registers. According to table 2, bit 1 defines if the receiver is set back to polling mode via the OFF command, (see chapter 'Receiving Mode') or if it is programmed. Bit 2 represents the register address. It selects the appropriate register to be programmed.

Table 2. Effect of Bit 1 and Bit 2 in programming the registers

Bit 1	Bit 2	Action
1	x	The receiver is set back to polling mode (OFF command)
0	1	The OPMODE register is programmed
0	0	The LIMIT register is programmed

Table 4 and the following illustrate the effect of the individual configuration words. The default configuration is highlighted for each word.

BR_Range sets the appropriate baud rate range. At the same time it defines XLim. XLim is used to define the bitcheck limits T_{Lim_min} and T_{Lim_max} as shown in table 4.

POUT can be used to control the sensitivity of the receiver. In that application, POUT is set to 1 to reduce the sensitivity. This implies that the receiver operates with full sensitivity after a POR.

Table 3. Effect of the configuration words within the registers

Bit1	Bit2	Bit3	Bit4	Bit5	Bit6	Bit7	Bit8	Bit9	Bit10	Bit11	Bit12	Bit13	Bit14
OFF command													
1													
OPMODE register													
0	1	BR_Range		N _{Bitcheck}		V _{POUT}	Sleep				XSleep		
0	1	Baud1	Baud0	BitChk1	BitChk0	POUT	Sleep4	Sleep3	Sleep2	Sleep1	Sleep0	X _{Sleep} Std	X _{Sleep} Temp
(Default)		0	0	1	0	0	0	1	0	1	1	0	0
LIMIT register													
0	0	Lim_min					Lim_max						
0	0	Lim_min5	Lim_min4	Lim_min3	Lim_min2	Lim_min1	Lim_min0	Lim_max5	Lim_max4	Lim_max3	Lim_max2	Lim_max1	Lim_max0
(Default)		0	0	1	1	1	0	0	1	1	0	0	0

Table 4. Effect of the configuration word BR_Range

BR_Range		Baudrate Range / Extension Factor for Bitcheck Limits (XLim)
Baud1	Baud0	
0	0	BR_Range0 (application USA / Europe: BR_Range0 = 1.0 kBaud to 1.8 kBaud) (Default) XLim = 8 (Default)
0	1	BR_Range1 (application USA / Europe: BR_Range1 = 1.8 kBaud to 3.2 kBaud) XLim = 4
1	0	BR_Range2 (application USA / Europe: BR_Range2 = 3.2 kBaud to 5.6 kBaud) XLim = 2
1	1	BR_Range3 (Application USA / Europe: BR_Range3 = 5.6 kBaud to 10 kBaud) XLim = 1

Table 5. Effect of the configuration word N_{Bitcheck}

N _{Bitcheck}		Number of Bits to be Checked
BitChk1	BitChk0	
0	0	0
0	1	3
1	0	6 (Default)
1	1	9

Table 6. Effect of the configuration Bit V_{POUT}

V _{POUT}	Level of the Multi-Purpose Output Port POUT
POUT	
0	0 (Default)
1	1

Table 7. Effect of the configuration word Sleep

Sleep					Start Value for Sleep Counter ($T_{\text{Sleep}} = \text{Sleep} \times X_{\text{Sleep}} \times 1024 \times T_{\text{CLK}}$)
Sleep4	Sleep3	Sleep2	Sleep1	Sleep0	
0	0	0	0	0	0 (Receiver is continuously polling until a valid signal occurs)
0	0	0	0	1	1 ($T_{\text{Sleep}} \approx 2\text{ms}$ for $X_{\text{Sleep}} = 1$ in US- / European applications)
0	0	0	1	0	2
0	0	0	1	1	3
.
.
.
0	1	0	1	1	11 (USA: $T_{\text{Sleep}} = 22.96 \text{ ms}$, Europe: $T_{\text{Sleep}} = 23.31 \text{ ms}$) (Default)
.
.
.
1	1	1	0	1	29
1	1	1	1	0	30
1	1	1	1	1	31 (Permanent sleep mode)

Table 8. Effect of the configuration word XSleep

XSleep		Extension Factor for Sleep Time ($T_{\text{Sleep}} = \text{Sleep} \times X_{\text{Sleep}} \times 1024 \times T_{\text{CLK}}$)
XSleepStd	XSleepTemp	
0	0	1 (Default)
0	1	8 (XSleep is reset to 1 if bitcheck fails once)
1	0	8 (XSleep is set permanently)
1	1	8 (XSleep is set permanently)

Table 9. Effect of the configuration word Lim_min

Lim_min						Lower Limit Value for Bitcheck
Lim_min < 10 is not applicable						($T_{\text{Lim_min}} = \text{Lim_min} \times X_{\text{Lim}} \times T_{\text{CLK}}$)
0	0	1	0	1	0	10
0	0	1	0	1	1	11
0	0	1	1	0	0	12
0	0	1	1	0	1	13
0	0	1	1	1	0	14 (Default) (USA: $T_{\text{Lim_min}} = 228 \mu\text{s}$, Europe: $T_{\text{Lim_min}} = 232 \mu\text{s}$)
.	
.	
.	
1	1	1	1	0	1	61
1	1	1	1	1	0	62
1	1	1	1	1	1	63

Table 10. Effect of the configuration word Lim_max

Lim_max						Upper Limit Value for Bitcheck
Lim_max < 12 is not applicable						$(T_{Lim_max} = (Lim_max - 1) \times XLim \times T_{Clk})$
0	0	1	1	0	0	12
0	0	1	1	0	1	13
0	0	1	1	1	0	14
.	
.	
.	
0	1	1	0	0	0	24 (Default)
						(USA: $T_{Lim_max} = 375 \mu s$, Europe: $T_{Lim_max} = 381 \mu s$)
.	
.	
.	
1	1	1	1	0	1	61
1	1	1	1	1	0	62
1	1	1	1	1	1	63

Conservation of the Register Information

The U3741BM implies an integrated power-on reset and brown-out detection circuitry to provide a mechanism to preserve the RAM register information.

According to figure 21, a power-on reset (POR) is generated if the supply voltage V_S drops below the threshold voltage $V_{ThReset}$. The default parameters are programmed into the configuration registers in that condition. Once V_S exceeds $V_{ThReset}$ the POR is canceled after the minimum reset period t_{Rst} . A POR is also generated when the supply voltage of the receiver is turned on.

To indicate that condition, the receiver displays a reset marker (RM) at Pin DATA after a reset. The RM is

represented by the fixed frequency f_{RM} at a 50% duty cycle. RM can be canceled via an 'L' pulse t_1 at Pin DATA. The RM implies the following characteristics:

- f_{RM} is lower than the lowest feasible frequency of a data signal. By this means, RM cannot be misinterpreted by the connected μC .
- If the receiver is set back to polling mode via pin DATA, RM cannot be canceled by accident if t_1 is applied according to the proposal in the section 'Programming the configuration registers'.

By means of that mechanism the receiver cannot lose its register information without communicating that condition via the reset marker RM.

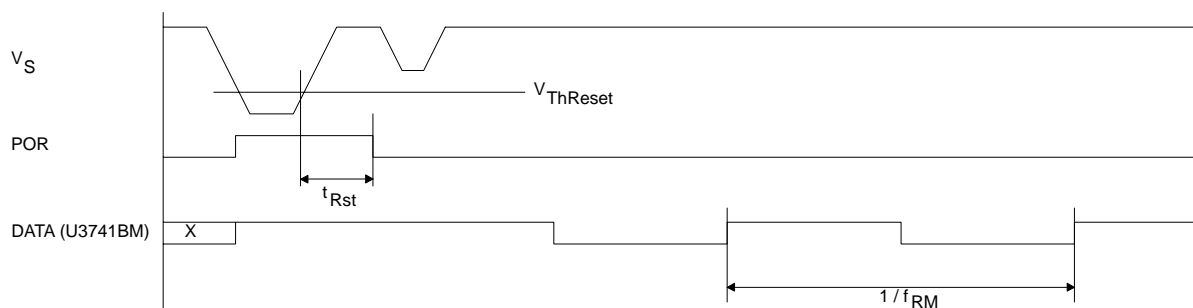

Figure 21. Generation of the power on reset

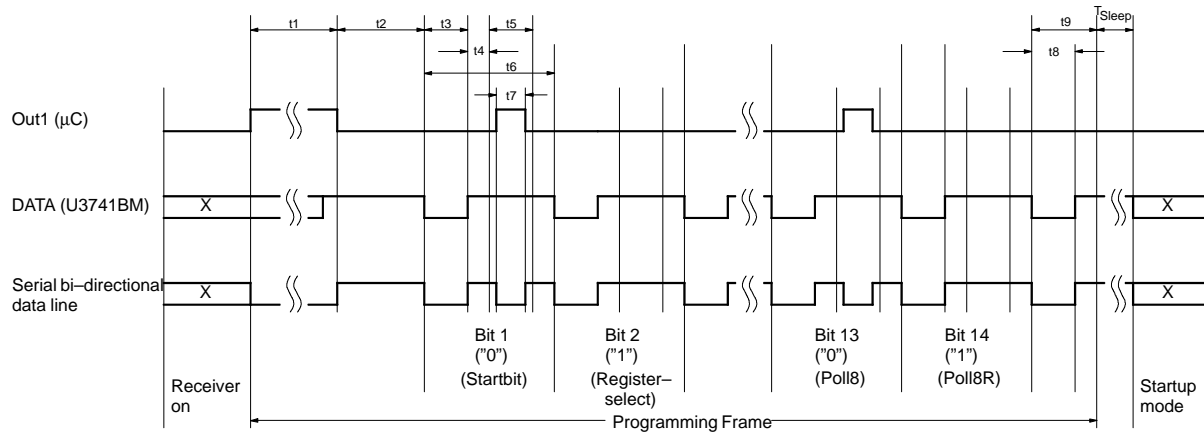

Figure 22. Timing of the register programming

Programming the Configuration Register

The configuration registers are programmed serially via the bi-directional data line according to figure 22 and figure 23.

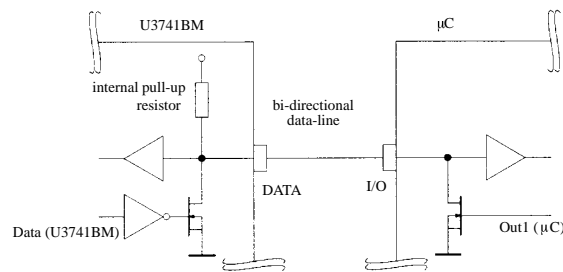

Figure 23. One wire connection to a µC

To start programming, the serial data line DATA is pulled to 'L' for the time period t_1 by the µC. When DATA has been released, the receiver becomes the master device. When the programming delay period t_2 has elapsed it emits 14 subsequent synchronization pulses with the pulse length t_3 . After each of these pulses a programming window occurs. The delay until the program window starts is determined by t_4 , the duration is defined by t_5 . Within the programming window, the individual bits are set. If the µC pulls down Pin DATA for the time period t_7 during t_5 , the according bit is set to '0'. If no programming pulse t_7 is issued, this bit is set to '1'. All 14 bits are subsequently programmed in this way. The time frame to program a bit is defined by t_6 .

Bit 14 is followed by the equivalent time window t_9 . During this window the equivalent acknowledge pulse t_8 (E_Ack) occurs if the just programmed modeword is equivalent to the modeword that was already stored in that register. E_Ack should be used to verify that the modeword was correctly transferred to the register. The register must be programmed twice in that case.

Programming of a register is possible both in the sleep- and in active-mode of the receiver.

During programming, the LNA, LO, lowpass filter IF-amplifier and the FSK/ASK Manchester demodulator are disabled.

The programming start pulse t_1 initiates the programming of the configuration registers. If bit 1 is set to '1', it represents the OFF-command to set the receiver back to polling mode at the same time. For the length of the programming start pulse t_1 , the following convention should be considered:

- $t_1(\min) < t_1 < 1535 \times T_{Clk}$: [$t_1(\min)$ is the minimum specified value for the relevant BR_Range]

Programming respectively OFF-command is initiated if the receiver is not in reset mode. If the receiver is in reset mode programming respectively Off-command is not initiated and the reset marker RM is still present at Pin DATA.

This period is generally used to switch the receiver to polling mode. In a reset condition, RM is not canceled by accident.

- $t_1 > 5632 \times T_{Clk}$

Programming respectively OFF-command is initiated in any case. RM is canceled if present.

This period is used if the connected µC detected RM. If a configuration register is programmed this time period for t_1 can generally be used.

Note that the capacitive load at Pin DATA is limited. The resulting time constant t together with an optional external pull-up resistor may not be exceeded to ensure proper operation.

Absolute Maximum Ratings

Parameters	Symbol	Min.	Typ.	Max.	Unit
Power dissipation	P_{tot}			450	mW
Junction temperature	T_j			150	°C
Storage temperature	T_{stg}	-55		+125	°C
Ambient temperature	T_{amb}	-40		+105	°C
Maximum input level, input matched to 50 Ω	P_{in_max}			10	dBm

Thermal Resistance

Parameters	Symbol	Value	Unit
Junction ambient	R_{thJA}	100	K/W

Electrical Characteristics

All parameters refer to GND, $T_{amb} = -40^{\circ}\text{C}$ to $+105^{\circ}\text{C}$, $V_S = 4.5\text{ V}$ to 5.5 V , $f_0 = 433.92\text{ MHz}$ and $f_0 = 315\text{ MHz}$, unless otherwise specified. ($V_S = 5\text{ V}$, $T_{amb} = 25^{\circ}\text{C}$)

Parameter	Test Condition	Symbol	6.76438 MHz Osc. (MODE: 1)			4.90625 MHz Osc. (MODE: 0)			Variable Oscillator			Unit
			Min.	Typ.	Max.	Min.	Typ.	Max.	Min.	Typ.	Max.	
Basic clock cycle of the digital circuitry												
Basic clock cycle	MODE = 0 (USA)	T_{Clk}					2.0383				$1/f_{XT0}/10$	μs
	MODE = 1 (Europe)			2.0697							$1/f_{XT0}/14$	μs
Extended basic clock cycle	BR_Range0	T_{XClk}		16.6			16.3				$8 \times T_{Clk}$	μs
	BR_Range1			8.3			8.2				$4 \times T_{Clk}$	μs
	BR_Range2			4.1			4.1				$2 \times T_{Clk}$	μs
	BR_Range3			2.1			2.0				$1 \times T_{Clk}$	μs
Polling mode												
Sleep time	Sleep and XSleep are defined in the OPMODE register	T_{Sleep}		Sleep \times XSleep \times 1024 \times 2.0697			Sleep \times XSleep \times 1024 \times 2.0383				Sleep \times XSleep \times 1024 \times T_{Clk}	ms
Startup time	BR_Range0	$T_{Startup}$		1855			1827				896.5	μs
	BR_Range1			1061			1045				512.5	μs
	BR_Range2			1061			1045				512.5	μs
	BR_Range3			663			653				320.5 $\times T_{Clk}$	μs
Time for Bitcheck	Average bitcheck time while polling	$T_{Bitcheck}$		0.45			0.47					ms
				0.24			0.26					ms
				0.14			0.16					ms
				0.14			0.15					ms
	Bitcheck time for a valid input signal	$T_{Bitcheck}$										
	f_{Sig}		0	0.166	0	0.164				$8 \times T_{Clk}$	ms	
	NBitcheck = 3		$3/f_{Sig}$	$3.5/f_{Sig}$	$3/f_{Sig}$	$3.5/f_{Sig}$				$3.5/f_{Sig}$	ms	
	NBitcheck = 6		$6/f_{Sig}$	$6.5/f_{Sig}$	$6/f_{Sig}$	$6.5/f_{Sig}$				$6.5/f_{Sig}$	ms	
	NBitcheck = 9		$9/f_{Sig}$	$9.5/f_{Sig}$	$9/f_{Sig}$	$9.5/f_{Sig}$				$9.5/f_{Sig}$	ms	
Receiving mode												
Intermediate frequency	MODE=0 (USA)	f_{IF}					1.0				$f_{XT0} \times 64 / 314$	MHz
	MODE=1 (Europe)			1.0							$f_{XT0} \times 64 / 432.92$	MHz
Baud rate range	BR_Range0	BR_Range	1.0		1.8	1.0	1.8				$BR_Range0 \times 2 \mu\text{s} / T_{Clk}$	kBaud
	BR_Range1		1.8		3.2	1.8	3.2				$BR_Range1 \times 2 \mu\text{s} / T_{Clk}$	kBaud
	BR_Range2		3.2		5.6	3.2	5.6				$BR_Range2 \times 2 \mu\text{s} / T_{Clk}$	kBaud
	BR_Range3		5.6		10.0	5.6	10.0				$BR_Range3 \times 2 \mu\text{s} / T_{Clk}$	kBaud

Electrical Characteristics (continued)

All parameters refer to GND, $T_{amb} = -40^{\circ}\text{C}$ to $+105^{\circ}\text{C}$, $V_S = 4.5\text{ V}$ to 5.5 V , $f_0 = 433.92\text{ MHz}$ and $f_0 = 315\text{ MHz}$, unless otherwise specified. ($V_S = 5\text{ V}$, $T_{amb} = 25^{\circ}\text{C}$)

Parameter	Test Condition	Symbol	6.76438 MHz Osc. (MODE: 1)			4.90625 MHz Osc. (MODE: 0)			Variable Oscillator			Unit
			Min.	Typ.	Max.	Min.	Typ.	Max.	Min.	Typ.	Max.	
Receiving mode (continued)												
Minimum time period between edges at Pin DATA (figure 17)	BR_Range0	T_{DATA_min} tmin1		149		147				$9 \times T_{XCLK}$		μs
	BR_Range1	tmin2		182		179			$11 \times T_{XCI}$		μs	
	BR_Range2	tmin1		75		73			$9 \times T_{XCLK}$		μs	
		tmin2		91		90			$11 \times T_{XCLK}$		μs	
	BR_Range3	tmin1		37.3		36.7			$9 \times T_{XCLK}$		μs	
		tmin2		45.5		44.8			$11 \times T_{XCI}$		μs	
Maximum low period at DATA (figure 18)	BR_Range0	$T_{DATA_L_max}$		2169		2136			$131 \times T_{XCLK}$		μs	
	BR_Range1			1085		1068			$131 \times T_{XCI}$		μs	
	BR_Range2			542		534			$131 \times T_{XCI}$		μs	
	BR_Range3			271		267			$131 \times T_{XCI}$		μs	
OFF command at Pin ENABLE (figure 20)		t_{Doze}	3.1			3.05			$1.5 \times T_{CLK}$		μs	
Configuration of the receiver												
Frequency of the reset marker (figure 21)		f_{RM}		117.9		119.8						Hz
									$\frac{1}{4096 \times T_{CLK}}$			
Programming start pulse (figure 19, figure 22)	BR_Range0	t1	2188		3176	2155		3128	$1057 \times T_{CLK}$		$1535 \times T_{CLK}$	μs
	BR_Range1		1104		3176	1087		3128	$533 \times T_{CLK}$		$1535 \times T_{CLK}$	
	BR_Range2		561		3176	553		3128	$271 \times T_{CLK}$		$1535 \times T_{CLK}$	
	BR_Range3 after POR		290		3176	286		3128	$140 \times T_{CLK}$		$1535 \times T_{CLK}$	
			11656			11479			$5632 \times T_{CLK}$			
Programming delay period (figure 19, figure 22)		t2	795		798	783		786	$384.5 \times T_{CLK}$		$385.5 \times T_{CLK}$	μs
Synchronization pulse (figure 19, figure 22)		t3		265			261		$128 \times T_{CLK}$			μs
Delay until of the program window starts (figure 19, figure 22)		t4		131			129		$63.5 \times T_{CLK}$			μs
Programming window (figure 19, figure 22)		t5		530			522		$256 \times T_{CLK}$			μs
Time frame of a bit (figure 22)		t6		1060			1044		$512 \times T_{CLK}$			μs
Programming pulse (figure 19, figure 22)		t7	133		529	131		521	$64 \times T_{CLK}$		$256 \times T_{CLK}$	μs
Equivalent acknowledge pulse: E_Ack (figure 22)		t8		265			261		$128 \times T_{CLK}$			μs
Equivalent time window (figure 22)		t9		534			526		$258 \times T_{CLK}$			μs
OFF-bit programming window (figure 19)		t10		930			916		$449.5 \times T_{CLK}$			μs

Electrical Characteristics (continued)

All parameters refer to GND, $T_{amb} = -40^{\circ}\text{C}$ to $+105^{\circ}\text{C}$, $V_S = 4.5\text{ V}$ to 5.5 V , $f_0 = 433.92\text{ MHz}$ and $f_0 = 315\text{ MHz}$, unless otherwise specified. ($V_S = 5\text{ V}$, $T_{amb} = 25^{\circ}\text{C}$)

Parameters	Test Conditions / Pins	Symbol	Min.	Typ.	Max.	Unit
Current consumption	Sleep mode (XTO and polling logic active)	I_{Soff}		190	276	μA
	IC active (startup-, bitcheck-, receiving mode) Pin DATA = H	I_{Son}		7.0	8.6	mA
LNA mixer						
Third-order intercept point	LNA/ mixer/ IF amplifier input matched according to figure 6	IIP3		-28		dBm
LO spurious emission @ RF_{in}	Input matched according to figure 6, required according to I-ETS 300220	IS_{LORF}		-73	-57	dBm
Noise figure LNA and mixer (DSB)	Input matching according to figure 6	NF		7		dB
LNA_IN input impedance	@ 433.92 MHz @ 315 MHz	Z_{iLNA_IN}		$1.0 \parallel 1.56$ $1.3 \parallel 1.0$		$k\Omega \parallel pF$ $k\Omega \parallel pF$
1 dB compression point (LNA, mixer, IF amplifier)	Input matched according to figure 6, referred to RF_{in}	IP_{1db}		-40		dBm
Maximum input level	Input matched according to figure 6, BER $\leq 10^{-3}$, FSK mode ASK mode	P_{in_max}			-28 -20	dBm dBm
Local oscillator						
Operating frequency range VCO		f_{VCO}	299		449	MHz
Phase noise VCO / LO	$f_{osc} = 432.92\text{ MHz}$ @ 1 MHz @ 10 MHz	L (fm)		-93 -113	-90 -110	dBc/Hz dBc/Hz
Spurious of the VCO	@ $\pm f_{XTO}$			-55	-47	dBc
VCO gain		K_{VCO}		190		MHz/V
Loop bandwidth of the PLL	For best LO noise (design parameter) $R1 = 820\ \Omega$ $C9 = 4.7\text{ nF}$ $C10 = 1\text{ nF}$	B_{Loop}		100		kHz
Capacitive load at Pin LF	The capacitive load at Pin LF is limited if bitcheck is used. The limitation therefore also applies to self polling.	C_{LF_tot}			10	nF
XTO operating frequency	XTO crystal frequency, appropriate load capacitance must be connected to XTAL 6.764375 MHz 4.90625 MHz	f_{XTO}	6.764375 -30 ppm 4.90625 -30 ppm	6.764375 4.90625	6.764375 +30 ppm 4.90625 +30 ppm	MHz MHz
Series resonance resistor of the crystal	$f_{XTO} = 6.764\text{ MHz}$ 4.906 MHz	R_S			150 220	Ω Ω
Static capacitance of the crystal		C_0			4	pF

Electrical Characteristics (continued)

All parameters refer to GND, $T_{amb} = -40^{\circ}\text{C}$ to $+105^{\circ}\text{C}$, $V_S = 4.5\text{ V}$ to 5.5 V , $f_0 = 433.92\text{ MHz}$ and $f_0 = 315\text{ MHz}$, unless otherwise specified. ($V_S = 5\text{ V}$, $T_{amb} = 25^{\circ}\text{C}$)

Parameters	Test Conditions / Pins	Symbol	Min.	Typ.	Max.	Unit	
Analog signal processing							
Input sensitivity ASK 300-kHz IF filter	Input matched according to figure 6 ASK (level of carrier) $BER \leq 10^{-3}$, $B = 300\text{ kHz}$ $f_{in} = 433.92\text{ MHz}/ 315\text{ MHz}$ $T = 25^{\circ}\text{C}$, $V_S = 5\text{ V}$ $f_{IF} = 1\text{ MHz}$	P_{Ref_ASK}					
	BR_Range0		-109	-111	-113	dBm	
	BR_Range1		-107	-109	-111	dBm	
	BR_Range2		-106	-108	-110	dBm	
	BR_Range3		-104	-106	-108	dBm	
Input sensitivity ASK 600 kHz IF filter	Input matched according to figure 6 ASK (level of carrier) $BER \leq 10^{-3}$, $B = 600\text{ kHz}$ $f_{in} = 433.92\text{ MHz}/ 315\text{ MHz}$ $T = 25^{\circ}\text{C}$, $V_S = 5\text{ V}$ $f_{IF} = 1\text{ MHz}$	P_{Ref_ASK}					
	BR_Range0		-108	-110	-112	dBm	
	BR_Range1		-106.5	-108.5	-110.5	dBm	
	BR_Range2		-106	-108	-110	dBm	
	BR_Range3		-104	-106	-108	dBm	
Sensitivity variation ASK for the full operating range compared to $T_{amb} = 25^{\circ}\text{C}$, $V_S = 5\text{ V}$	300-kHz and 600-kHz version $f_{in} = 433.92\text{ MHz}/ 315\text{ MHz}$ $f_{IF} = 1\text{ MHz}$ $P_{ASK} = P_{Ref_ASK} + \Delta P_{Ref}$	ΔP_{Ref}	+2.5		-1.5	dB	
Sensitivity variation ASK for full operating range including IF filter compared to $T_{amb} = 25^{\circ}\text{C}$, $V_S = 5\text{ V}$	300-kHz version $f_{in} = 433.92\text{ MHz}/ 315\text{ MHz}$ $f_{IF} = 0.88\text{ MHz}$ to 1.12 MHz $f_{IF} = 0.85\text{ MHz}$ to 1.15 MHz $P_{ASK} = P_{Ref_ASK} + \Delta P_{Ref}$	ΔP_{Ref}	+5.5 +7.5		-1.5 -1.5	dB dB	
	600-kHz version $f_{in} = 433.92\text{ MHz}/ 315\text{ MHz}$ $f_{IF} = 0.79\text{ MHz}$ to 1.21 MHz $f_{IF} = 0.73\text{ MHz}$ to 1.27 MHz $P_{ASK} = P_{Ref_ASK} + \Delta P_{Ref}$	ΔP_{Ref}	+5.5 +7.5		-1.5 -1.5	dB dB	
	Input sensitivity FSK 600 kHz IF filter	Input matched according to figure 6, $BER \leq 10^{-3}$, $B = 600\text{ kHz}$ $f_{in} = 433.92\text{ MHz}/ 315\text{ MHz}$ $T = 25^{\circ}\text{C}$, $V_S = 5\text{ V}$ $f_{IF} = 1\text{ MHz}$	P_{Ref_FSK}				
	BR_Range0 $df \geq \pm 20\text{ kHz}$ $df \geq \pm 30\text{ kHz}$		-95.5 -96.5	-97.5 -98.5	-99.5 100.5	dBm dBm	
BR_Range1 $df \geq \pm 20\text{ kHz}$ $df \geq \pm 30\text{ kHz}$		-94.5 -95.5	-96.5 -97.5	-98.5 -99.5	dBm dBm		

Electrical Characteristics (continued)

All parameters refer to GND, $T_{amb} = -40^{\circ}\text{C}$ to $+105^{\circ}\text{C}$, $V_S = 4.5\text{ V}$ to 5.5 V , $f_0 = 433.92\text{ MHz}$ and $f_0 = 315\text{ MHz}$, unless otherwise specified. ($V_S = 5\text{ V}$, $T_{amb} = 25^{\circ}\text{C}$)

Parameters	Test Conditions / Pins	Symbol	Min.	Typ.	Max.	Unit
Sensitivity variation FSK for the full operating range compared to $T_{amb} = 25^{\circ}\text{C}$, $V_S = 5\text{ V}$	300-kHz and 600-kHz version $f_{in} = 433.92\text{ MHz}/ 315\text{ MHz}$ $f_{IF} = 1\text{ MHz}$ $P_{FSK} = P_{Ref_FSK} + \Delta P_{Ref}$	ΔP_{Ref}	+2.5		-1.5	dB
Sensitivity variation FSK for full operating range including IF filter compared to $T_{amb} = 25^{\circ}\text{C}$, $V_S = 5\text{ V}$	600-kHz version $f_{in} = 433.92\text{ MHz}/ 315\text{ MHz}$ $f_{IF} = 0.86\text{ MHz}$ to 1.14 MHz $f_{IF} = 0.82\text{ MHz}$ to 1.18 MHz $P_{FSK} = P_{Ref_FSK} + \Delta P_{Ref}$	ΔP_{Ref}	+5.5 +7.5		-1.5 -1.5	dB dB
FSK frequency deviation	The sensitivity of the receiver is higher for higher values of Δf_{FSK} BR_Range0 BR_Range1 BR_Range2 and BR_Range3 are not suitable for FSK operation	Δf_{FSK}	20 20	30 30	50 50	kHz kHz
S/N ratio to suppress inband noise signals	ASK mode FSK mode	SNR_{ASK} SNR_{FSK}	10 2		12 3	dB dB
Dynamic range RSSI ampl.		DR_{RSSI}		60		dB
Lower cut-off frequency of the data filter	$f_{cu_DF} = \frac{1}{2 \times \pi \times 30\text{k}\Omega \times \text{CDEM}}$ CDEM = 33 nF	f_{cu_DF}	0.11	0.16	0.20	kHz
Recommended CDEM for best performance	ASK mode BR_Range0 (Default) BR_Range1 BR_Range2 BR_Range3	CDEM		39 22 12 8.2		nF nF nF nF
	FSK mode BR_Range0 (Default) BR_Range1 BR_Range2 and BR_Range3 are not suitable for FSK operation	CDEM		27 15		nF nF
Maximum edge-to-edge time period of the input data signal for full sensitivity	BR_Range0 (Default) BR_Range1 BR_Range2 BR_Range3	t_{ee_sig}			1000 560 320 180	μs μs μs μs
Upper cut-off frequency data filter	Upper cut-off frequency programmable in 4 ranges via a serial mode word BR_Range0 (Default) BR_Range1 BR_Range2 BR_Range3	f_u	2.5 4.3 7.6 13.6	3.1 5.4 9.5 17.0	3.7 6.5 11.4 20.4	kHz kHz kHz kHz
Minimum edge-to-edge time period of the input data signal for full sensitivity	BR_Range0 (Default) BR_Range1 BR_Range2 BR_Range3	t_{ee_sig}			270 156 89 50	μs μs μs μs

Electrical Characteristics (continued)

All parameters refer to GND, $T_{amb} = -40^{\circ}\text{C}$ to $+105^{\circ}\text{C}$, $V_S = 4.5\text{ V}$ to 5.5 V , $f_0 = 433.92\text{ MHz}$ and $f_0 = 315\text{ MHz}$, unless otherwise specified. ($V_S = 5\text{ V}$, $T_{amb} = 25^{\circ}\text{C}$)

Parameters	Test Conditions / Pins	Symbol	Min.	Typ.	Max.	Unit
Reduced sensitivity	R_{Sense} connected from Pin Sens to V_S , input matched according to figure 6	P_{Ref_Red}				dBm (peak level)
	$R_{Sense} = 56\text{ k}\Omega$, $f_{in} = 433.92\text{ MHz}$, ($V_S = 5\text{ V}$, $T_{amb} = 25^{\circ}\text{C}$) @ $B = 300\text{ kHz}$ @ $B = 600\text{ kHz}$		-71 -67	-76 -72	-81 -77	dBm dBm
	$R_{Sense} = 100\text{ k}\Omega$, $f_{in} = 433.92\text{ MHz}$ @ $B = 300\text{ kHz}$ @ $B = 600\text{ kHz}$		-80 -76	-85 -81	-90 -86	dBm dBm
	$R_{Sense} = 56\text{ k}\Omega$, $f_{in} = 315\text{ MHz}$ @ $B = 300\text{ kHz}$ @ $B = 600\text{ kHz}$		-72 -68	-77 -73	-82 -78	dBm dBm
	$R_{Sense} = 100\text{ k}\Omega$, $f_{in} = 315\text{ MHz}$ @ $B = 300\text{ kHz}$ @ $B = 600\text{ kHz}$		-81 -77	-86 -82	-91 -87	dBm dBm
Reduced sensitivity variation over full operating range	$R_{Sense} = 56\text{ k}\Omega$ $R_{Sense} = 100\text{ k}\Omega$ $P_{Red} = P_{Ref_Red} + \Delta P_{Red}$	ΔP_{Red}	5 6	0 0	0 0	dB dB
	Values relative to $R_{Sense} = 56\text{ k}\Omega$ $R_{Sense} = 56\text{ k}\Omega$ $R_{Sense} = 68\text{ k}\Omega$ $R_{Sense} = 82\text{ k}\Omega$ $R_{Sense} = 100\text{ k}\Omega$ $R_{Sense} = 120\text{ k}\Omega$ $R_{Sense} = 150\text{ k}\Omega$ $P_{Red} = P_{Ref_Red} + \Delta P_{Red}$	ΔP_{Red}	0 -3.5 -6.0 -9.0 -11.0 -13.5			dB dB dB dB dB dB
Threshold voltage for reset		$V_{ThRESET}$	1.95	2.8	3.75	V
Digital ports						
Data output – Saturation voltage LOW – Internal pull-up resistor – Maximum time constant – Maximum caoactive load	$I_{Ol} = 1\text{ mA}$ $\tau = C_L (R_{Pup}/R_{Ext})$ without ext. pull-up resistor $R_{ext} = 5\text{ k}\Omega$	V_{Ol} R_{Pup} τ C_L C_L	39	0.08 50	0.3 61 2.5 41 540	V k Ω μs pF pF
POUT output – Saturation voltage LOW – Saturation voltage HIGH	$I_{POUT} = 1\text{ mA}$ $I_{POUT} = -1\text{ mA}$	V_{Ol} V_{Oh}	$V_S - 0.3\text{V}$	0.08 $V_S - 0.14\text{V}$	0.3	V V
FSK/ASK input – Low level input voltage – High level input voltage	FSK selected ASK selected	V_{Il} V_{Ih}	$0.8 \times V_S$		$0.2 \times V_S$	V V
ENABLE input – Low level input voltage – High level input voltage	Idle mode Active mode	V_{Il} V_{Ih}	$0.8 \times V_S$		$0.2 \times V_S$	V V
MODE input – Low level input voltage – High level input voltage	Division factor = 10 Division factor = 14	V_{Il} V_{Ih}	$0.8 \times V_S$		$0.2 \times V_S$	V V
TEST input – Low level input voltage	Test input must always be set to LOW	V_{Il}			$0.2 \times V_S$	V

Package Information

Package SO20

Dimensions in mm

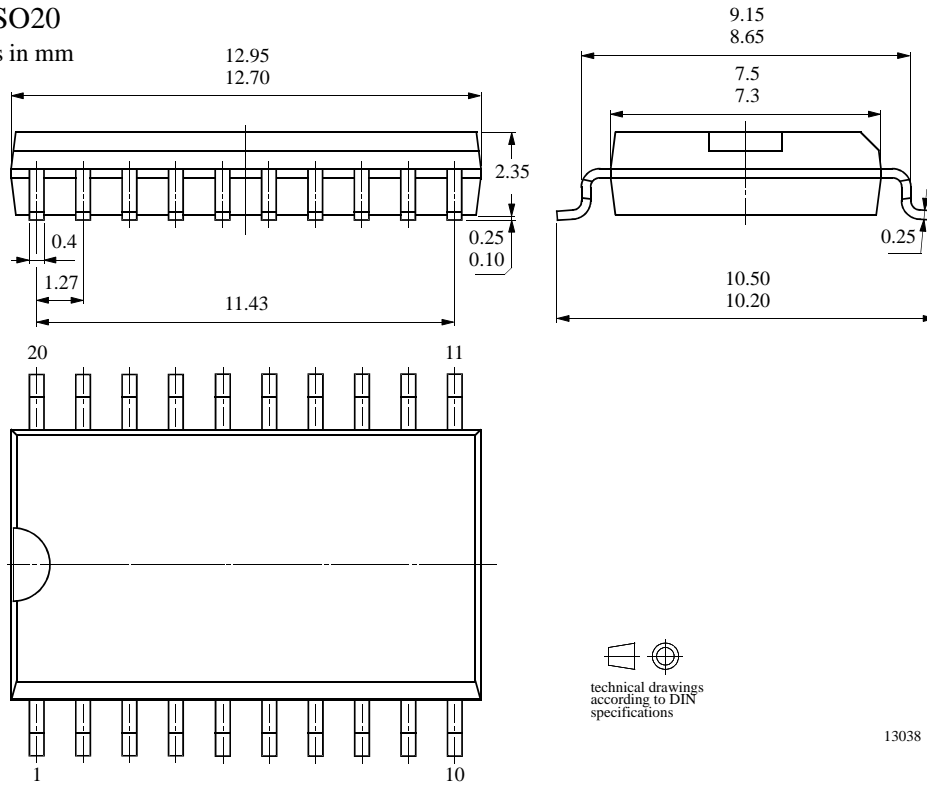

Ozone Depleting Substances Policy Statement

It is the policy of **TEMIC Semiconductor GmbH** to

1. Meet all present and future national and international statutory requirements.
2. Regularly and continuously improve the performance of our products, processes, distribution and operating systems with respect to their impact on the health and safety of our employees and the public, as well as their impact on the environment.

It is particular concern to control or eliminate releases of those substances into the atmosphere which are known as ozone depleting substances (ODSs).

The Montreal Protocol (1987) and its London Amendments (1990) intend to severely restrict the use of ODSs and forbid their use within the next ten years. Various national and international initiatives are pressing for an earlier ban on these substances.

TEMIC Semiconductor GmbH has been able to use its policy of continuous improvements to eliminate the use of ODSs listed in the following documents.

1. Annex A, B and list of transitional substances of the Montreal Protocol and the London Amendments respectively
2. Class I and II ozone depleting substances in the Clean Air Act Amendments of 1990 by the Environmental Protection Agency (EPA) in the USA
3. Council Decision 88/540/EEC and 91/690/EEC Annex A, B and C (transitional substances) respectively.

TEMIC Semiconductor GmbH can certify that our semiconductors are not manufactured with ozone depleting substances and do not contain such substances.

We reserve the right to make changes to improve technical design and may do so without further notice.

Parameters can vary in different applications. All operating parameters must be validated for each customer application by the customer. Should the buyer use TEMIC products for any unintended or unauthorized application, the buyer shall indemnify TEMIC against all claims, costs, damages, and expenses, arising out of, directly or indirectly, any claim of personal damage, injury or death associated with such unintended or unauthorized use.

TEMIC Semiconductor GmbH, P.O.B. 3535, D-74025 Heilbronn, Germany
Telephone: 49 (0)7131 67 2594, Fax number: 49 (0)7131 67 2423