



TMX AT11

SAW Bandpass Filter – WCDMA Tx - RF
Preliminary Specification (Rev 1)

▣ Features.....	P01
▣ Package Drawing & Pin out.....	P01
▣ Technical Characteristics	P02
▣ Matching Network	P02
▣ Nominal Response.....	P03
▣ Maximum Ratings.....	P04
▣ Marking & Packaging	P04

TMX AT11

SAW Bandpass Filter – WCDMA Tx - RF

Preliminary Specification (Rev.1)- RF

February 3rd, 2006

Features

- ❑ Tx SAW Filter for WCDMA
- ❑ 1950 MHz Center Frequency
- ❑ 60 MHz useable Passband
- ❑ 200 Ohms Balanced Input / 50 Ohms Single Output Configuration
- ❑ Ceramic package for Surface Mounted Technology

Package Drawing & Pin out

The product is in conformance with the European RoHs Regulation 2002/95.

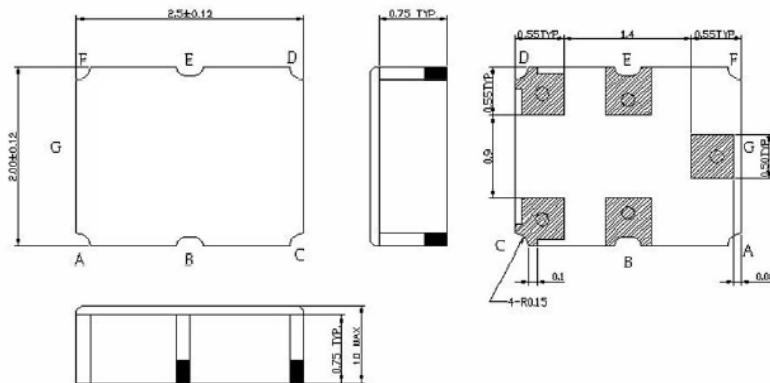

Pin Configuration

Input	C, D
Output	G
Case ground	B, E

TMX AT11

SAW Bandpass Filter – WCDMA Tx - RF

Preliminary Specification (Rev.1)- RF

February 3rd, 2006

Technical Characteristics

Reference Temperature : +25°C

Electrical Parameters	Unit	Minimum	Typical ⁽¹⁾	Maximum
Source Impedance (balanced)	Ohms	-	200	-
Load Impedance (single)	Ohms	-	50	-
Center Frequency f_c	MHz	-	1950	-
Bandwidth at -3dB	MHz	60	-	-
Absolute Attenuation				
0 to 1805 MHz	dB	20	30	-
1805 MHz to 1860 MHz	dB	22	35	-
1860 MHz to 1880 MHz	dB	15	20	-
2110 MHz to 2170 MHz	dB	20	25	-
2170 MHz to 2670 MHz	dB	25	38	-
2680 MHz to 2740 MHz	dB	20	40	-
3840 MHz to 3960 MHz	dB	15	53	-
5760 MHz to 5940 MHz	dB	15	44	-
Symmetry in band (referenced to the matched operating condition)				
$ S_{21} / S_{31} $ within 1920 MHz – 1980 MHz	dB	-2.2	0	2.2
$\angle(S_{21}) - \angle(S_{31}) + 180^\circ$ within 1920MHz-1980MHz	deg	-18	0	18
Insertion Loss within 1920 MHz – 1980 MHz	dB	-	2.6	4.0
Amplitude ripple within 1920 MHz – 1980 MHz	dB	-	0.4	1.8
Input VSWR within 1920 MHz – 1980 MHz		-	1.8	2.4
Output VSWR within 1920 MHz – 1980 MHz		-	2.0	2.4

Matching Network

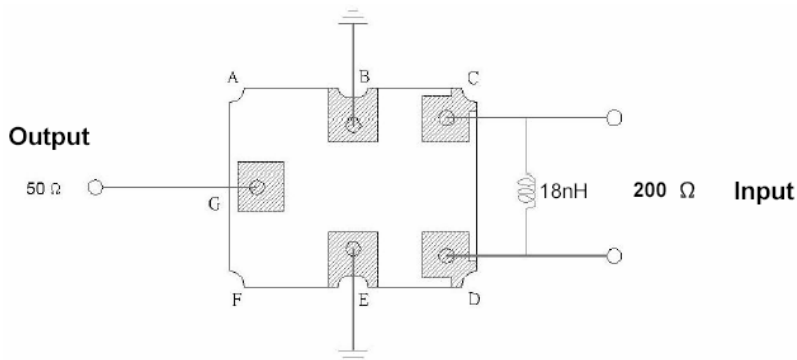

TMX AT11

SAW Bandpass Filter – WCDMA Tx - RF

Preliminary Specification (Rev.1)- RF

February 3rd, 2006

Nominal Frequency Response (Measurements)

Frequency Response

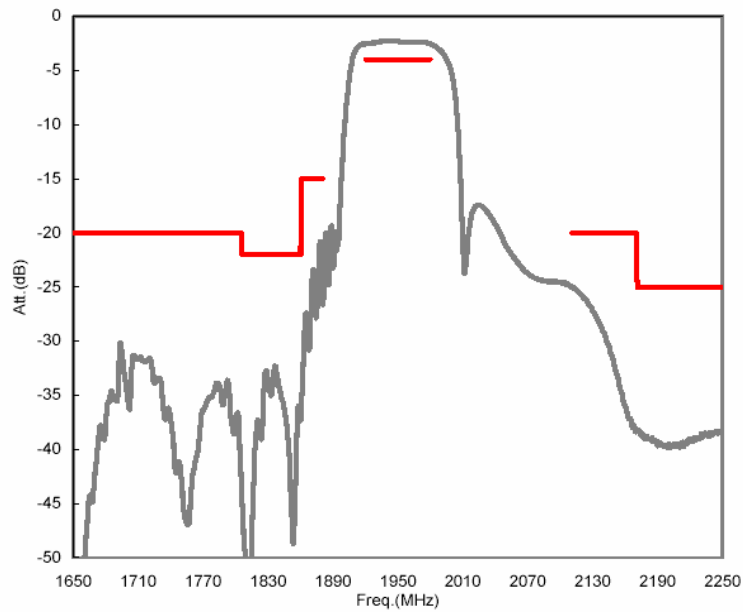

TMX AT11

SAW Bandpass Filter – WCDMA Tx - RF

Preliminary Specification (Rev.1)- RF

February 3rd, 2006

Maximum Ratings

Storage Temperature Range	°C	[-10°C ; +85°C]
Operating temperature	°C	[-40°C ; +85°C]

Marking

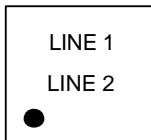

Line 1: "P C" with P for the code product identification and C for the partner identifier

Line 2: "Y W" with Y for the last digit of the year and W for the week code (A to Z for the week 1 to 26 and a to z for the week 27 to 52).

Packaging

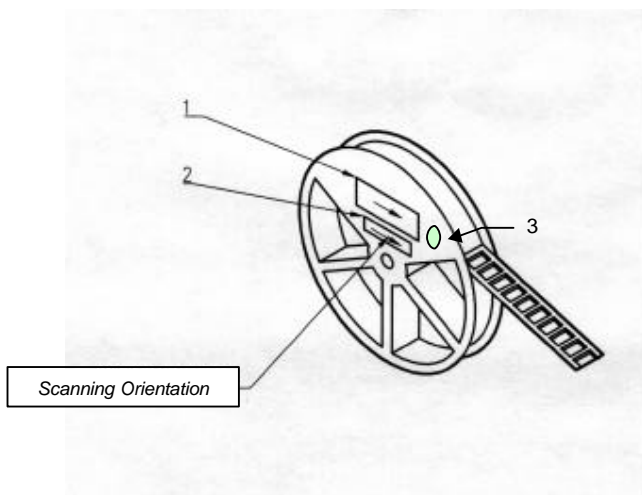

- 1 – Temex Label
- 2 – ESD Prevention Label
- 3 – Pb Free Label