

DFC10 SERIES DUAL OUTPUT

DESCRIPTION

The dual output DFC10 Series provides power solutions to meet commercial and industrial requirements. With power densities above 11 watts per cubic inch (0.67 watts per cm³), overcurrent protection, and five sided shielded case, the DFC10 meets rigorous needs in an industry standard case size. The 120KHz operating frequency of the DFC10 Series allows an increased power density while including adequate heat sinking and input/output filtering. This eliminates the need for external components in most applications. Full overload protection is provided by pulse-by-pulse current limiting on models with 48V input.

FEATURES

- High Power Density, up to 11 Watts per Cubic Inch
- Efficiencies to 79%
- Fully Isolated, Fully Filtered Design
- Greater than 700V Isolation
- Overcurrent Protection
- Five-Side Shielded Copper Case
- Ultra Wide Range Input (4:1)

Selection Chart					
Model	Input Range VDC		Output		
	Min	Max	VDC	mA	Power W
DFC10U24D5	9	36	±5	±850	9
DFC10U24D12	9	36	±12	±400	10
DFC10U24D15	9	36	±15	±320	10
DFC10U48D5	18	72	±5	±800	8
DFC10U48D12	18	72	±12	±415	10
DFC10U48D15	18	72	±15	±330	10

General Specifications (1)			
All Models			Units
Isolation (2)			
Isolation Voltage Input to Output 10 µA Leakage	MIN	700	VDC
Input to Output Capacitance	TYP	350	pF
Environmental			
Case Operating Range, Tc	MIN MAX	-40 85	°C
Case Functional Range (3)	MIN MAX	-50 100	°C
Storage Range	MIN MAX	-55 105	°C
General			
MTBF (Calculated)	TYP	800,000	HRS
Thermal Impedance (4)	TYP	16	°C/Watt
Unit Weight	TYP	1.2/34	oz/gm
Mounting Options			
Chassis Mounting Kit 24V	CM2B2		
Chassis Mounting Kit 48V	CM2A2		

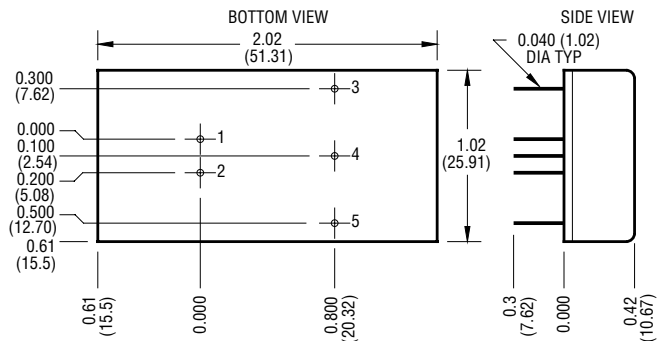

Mechanical tolerances unless otherwise noted:
 X.XX dimensions: ±0.03 inches
 X.XXX dimensions: ±0.005 inches

Pin	Function
1	+ INPUT
2	- INPUT
3	+ OUTPUT
4	COMMON
5	- OUTPUT

NOTES

- (1) All parameters measured at Tc = 25°C, nominal input voltage and full rated load unless otherwise noted. Refer to the Technical Reference Section for the definition of terms, measurement circuits and other information.
- (2) Case is tied to the COMMON output pin.
- (3) The functional temperature range is intended to give an additional data point for use in evaluating this power supply. At the low functional temperature the power supply will function with no side effects, however, sustained operation at the high functional temperature will reduce expected operational life. The data sheet specifications are not guaranteed beyond the case operating range.
- (4) The case thermal impedance is specified as the case temperature rise over ambient per package watt dissipated.

NUCLEAR AND MEDICAL APPLICATIONS Power-One products are not authorized for use as critical components in life support systems, equipment used in hazardous environments, or nuclear control systems without the express written consent of the President of Power-One, Inc.

TECHNICAL REVISIONS The appearance of products, including safety agency certifications pictured on labels, may change depending on the date manufactured. Specifications are subject to change without notice.

DFC10 SERIES – DUAL OUTPUT

Input Parameters (1)								
Model		DFC10U24D5	DFC10U24D12	DFC10U24D15	DFC10U48D5	DFC10U48D12	DFC10U48D15	Units
Voltage Range	MIN	9			18			VDC
	MAX	36			72			
Input Current Full Load No Load	TYP	450	510	510	210	265	260	mA
	TYP	10	15	15	2	4	4	
Efficiency	TYP	79	78	78	79	78	79	%
Switching Frequency	TYP	100			120			kHz
Maximum Input Overvoltage, 100ms Maximum	MAX	45			85			VDC
Turn-on Time, 1% Output Error	TYP	20						ms

Output Parameters (1)								
Model		DFC10U24D5	DFC10U24D12	DFC10U24D15	DFC10U48D5	DFC10U48D12	DFC10U48D15	Units
Output Voltage		±5	±12	±15	±5	±12	±15	VDC
Output Voltage Accuracy	MIN	±4.95	±11.90	±14.90	±4.95	±11.90	±14.90	VDC
	TYP	±5.00	±12.00	±15.00	±5.00	±12.00	±15.00	
	MAX	±5.05	±12.10	±15.10	±5.05	±12.10	±15.10	
Rated Load Range (3)	MIN	0	0	0	0	0	0	mA
	MAX	±850	±400	±320	±800	±415	±330	
Load Regulation (4) 25% Max load to Max Load	TYP	0.1	0.1	0.1	0.3	0.2	0.2	%
	MAX	0.5	0.5	0.5	1.0	1.0	1.0	
Cross Regulation (5)	TYP	3	3	3	3	3	3	%
Line Regulation	TYP	0.1	0.1	0.1	0.3	0.1	0.1	%
	MAX	0.7	0.3	0.3	0.75	0.5	0.5	
Short Term Stability (6)	TYP	< 0.01			< 0.01			%/24Hrs
Long Term Stability	TYP	< 0.1			< 0.1			%/kHrs
Noise, Peak - Peak (2)	TYP	100						mV _{PP}
RMS Noise	TYP	35						mV _{rms}
Temperature Coefficient	TYP	50						ppm/°C
	MAX	250						
Short Circuit Protection		Short Term Current Limit			Pulse by Pulse Current Limit			

NOTES

- (1) All parameters measured at T_c = 25°C, nominal input voltage and full rated load unless otherwise noted. Refer to the Technical Reference Section for the definition of terms, measurement circuits and other information.
- (2) Noise is measured per Technical Reference Section. Measurement bandwidth is 0-20 MHz. RMS noise is measured over a 0.01-1 MHz bandwidth. To simulate standard PCB decoupling practices, output noise is measured with a 10µF tantalum and 0.01µF ceramic capacitor located 1 inch away from the converter.
- (3) The converter may be safely operated at any load from zero to the full rating. Dynamic response of the converter may degrade if the converter is operated with less than 25% output load.
- (4) Load regulation is defined for loading/unloading both outputs simultaneously. Load range is 25 to 100%.
- (5) Cross regulation is defined for loading/unloading one output while the other output is kept at full load. Load range is 25 to 100%.
- (6) Short term stability is specified after a 30 minute warmup at full load, constant line and recording the drift over a 24 hour period.

DFC10 SERIES APPLICATION NOTES:

External Capacitance Requirements

No external capacitance is required for operation of the DFC10 Series. If a capacitive input source is farther than 1" from the converter, an additional capacitor may be required at the input pins for proper operation. This input capacitor should have an ESR greater than 0.25 ohms. Input capacitors with an ESR less than 0.25 ohms may cause peaking of the input filter and actually degrade circuit performance.

External output capacitance is not required for operation, however it is recommended that 1µF to 10µF of tantalum and 0.001 to 0.1µF ceramic capacitance be selected for reduced system noise. Additional output capacitance may be added for increased filtering, but should not exceed 400µF.

DFC10 SERIES – DUAL OUTPUT

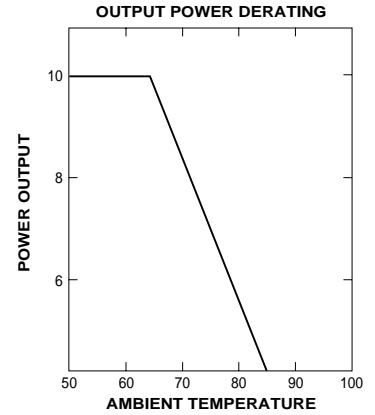
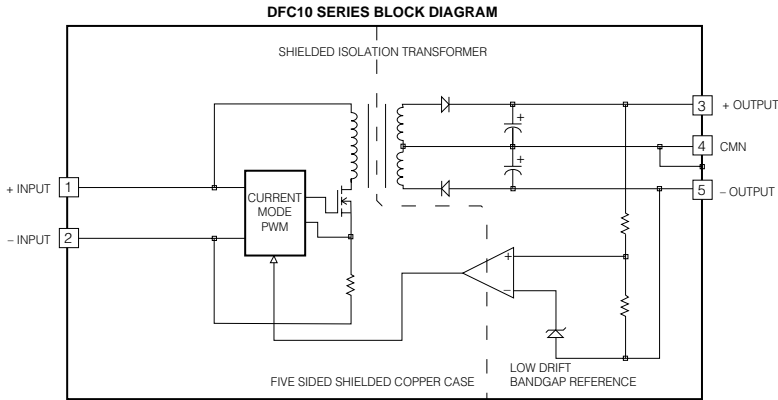

24 Volt Input

Typical Performance:
(T_c=25°C, V_{in}=Nom VDC,
Rated Load)

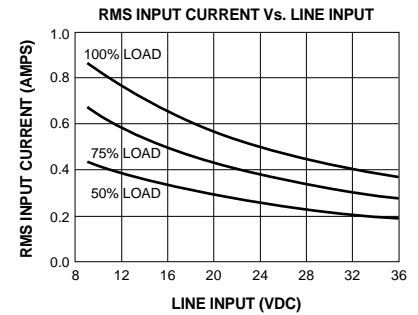
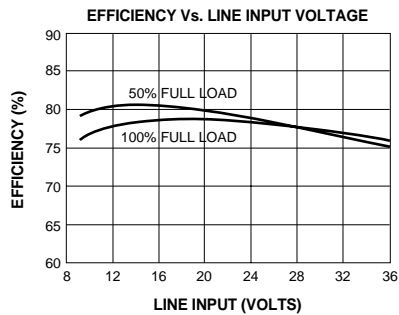
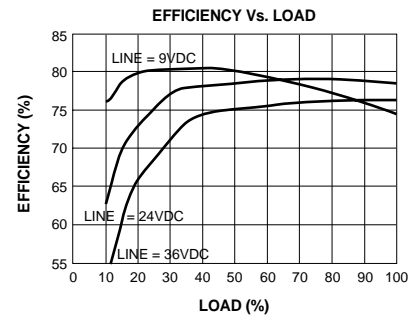
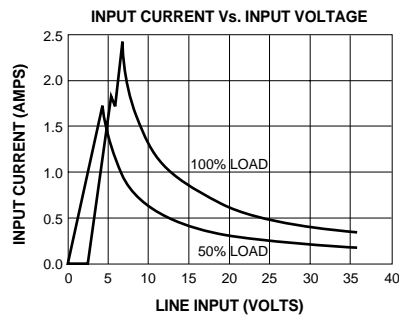

48 Volt Input

Typical Performance:
(T_c=25°C, V_{in}=Nom VDC,
Rated Load)

