

NEC**L, S Band SPDT GaAs MMIC Switch****UPG154TB****FEATURES**

- **LOW INSERTION LOSS:**
L_{INS} = 0.65 dB TYP at V_{CONT} = +3.0 V/0 V, V_{DD} = +3 V, C_X = 2 pF, f = 2 GHz
- **HIGH POWER SWITCHING:**
P_{in} (1 dB) = +30 dBm TYP at V_{CONT} = +3.0 V/0 V, V_{DD} = +3 V, C_X = 2 pF, f = 2 GHz
- **SMALL 6 PIN MINI-MOLD PACKAGE:**
Size: 2.0 x 1.25 x 0.9 mm

DESCRIPTION

The UPG154TB is an L-band SPDT (Single Pole Double Throw) GaAs FET switch for digital cellular or cordless telephone application. The device can operate from 100 MHz to 2.5 GHz with low insertion loss. This device is housed in an original 6 pin super mini-mold package similar to SOT363.

NEC's stringent quality assurance and test procedures assure the highest reliability and performance.

APPLICATION

- **L, S-BAND DIGITAL CELLULAR OR CORDLESS TELEPHONE**
- **PCS, WLAN AND WLL APPLICATIONS**

ELECTRICAL CHARACTERISTICS

(Unless otherwise specified, T_A = 25°C, V_{CONT1} = 3 V, V_{CONT2} = 0 V or V_{CONT1} = 0 V, V_{CONT2} = 3 V; off chip DC blocking capacitor value, 51 pF)

PART NUMBER PACKAGE OUTLINE			UPG154TB S06		
SYMBOLS	PARAMETERS AND CONDITIONS	UNITS	MIN	TYP	MAX
L _{INS}	Insertion Loss f = 0.1 – 1 GHz, C _X = 12 pF f = 2.0 GHz, C _X = 2 pF	dB		0.3 0.65	0.65 0.90
I _{SL}	Isolation f = 1 GHz, C _X = 12 pF f = 1.5 GHz, C _X = 4.5 pF f = 2 GHz, C _X = 2 pF	dB	20 18	24 22 21	
R _{LIN}	Input Return Loss f = 0.1 - 2 GHz, C _X = 2 pF	dB	11	15	
R _{LOUT}	Output Return Loss f = 0.1 - 2 GHz, C _X = 2 pF	dB	11	15	
P _{IN(1 dB)}	Input Power 1 dB Compression Point, f = 2 GHz, C _X = 2 pF	dBm	27	30	
P _{IN(0.1 dB)}	Input Power 0.1 dB Compression Point, f = 2 GHz, C _X = 2 pF	dBm		26.5	
t _{sw}	Switching Speed	ns		30	
I _{CONT}	Control Current at V _{CONT} = 3 V/0 V, no RF signal	μA		2	10

Note:

1. When the UPG154TB is used, it is necessary to use DC blocking capacitors for the RF input and RF output. The value of DC blocking capacitors should be chosen to accommodate the frequency of operation. The range of recommended DC blocking capacitor value is less than 100 pF.
2. The distance between IC's GND pin and ground pattern of substrate should be as short as possible to avoid parasitics.

ABSOLUTE MAXIMUM RATINGS¹ (T_A = 25°C)

SYMBOLS	PARAMETERS	UNITS	RATINGS
V _{CONT1,2}	Control Voltage 1, 2 ²	V	-6 to +6
V _{DD}	Supply Voltage	V	5
P _{IN}	Input Power	dBm	+31
P _{TOT}	Total Power Dissipation ³	W	0.15
T _A	Operating Temperature	°C	-45 to +85
T _{STG}	Storage Temperature	°C	-55 to +150

Notes:

1. Operation in excess of any one of these conditions may result in permanent damage.
2. $2.5\text{ V} \leq |V_{CONT1} - V_{CONT2}| \leq 6\text{ V}$
3. Mounted on a 50 x 50 x 1.6 mm double copper clad epoxy glass PWB, T_A = +85 °C.

RECOMMENDED OPERATING CONDITIONS (T_A = 25°C)

SYMBOL	PARAMETER	UNITS	UPG154TB		
			MIN	TYP	MAX
V _{CONT}	Control Voltage (High)	V	+2.5	+3.0	+5.3
V _{CONT}	Control Voltage (Low)	V	-0.2	0	+0.2
V _{DD}	Supply Voltage	V	+2.5	V _{CONT(H)}	V _{CONT(H)} +0.3

TEST CIRCUIT¹

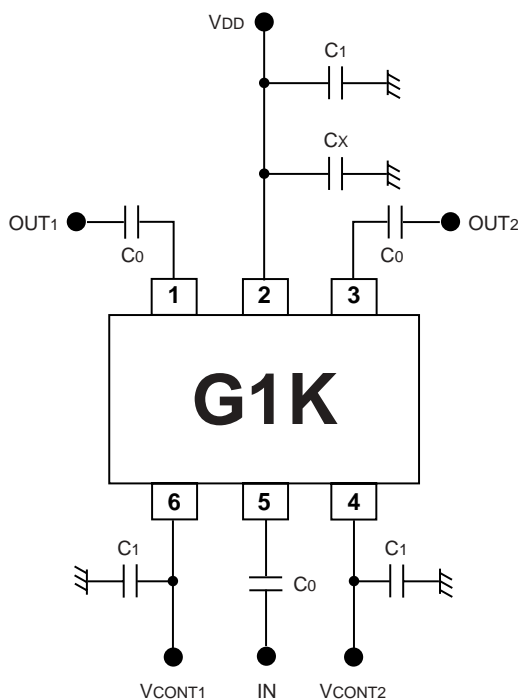

Note:

1. (T_A = 25°C, V_{CONT1} = +3 V, V_{CONT2} = 0 V or V_{CONT1} = 0 V, V_{CONT2} = +3 V, V_{DD} = +3 V, f = 2 GHz. Off chip DC blocking capacitors value: C₀ = 51 pF, C₁ = 1000 pF (Bypass: Select a suitable value for your application, especially concerning switching speed). C_x = 2 pF (In case of 2 GHz).
2. For optimum isolation, C_x should be placed as close as possible to pin 2.

TRUTH TABLE OF SWITCHING BY CONDITION OF CONTROL VOLTAGE

		V _{CONT1}	
		V _{CONT(H)}	V _{CONT(L)}
V _{CONT2}	V _{CONT(H)}		
	V _{CONT(L)}		

PIN CONNECTION DIAGRAM

PIN NO.	CONNECTION
1	OUT1
2	V _{DD}
3	OUT2
4	V _{CONT2}
5	IN
6	V _{CONT1}

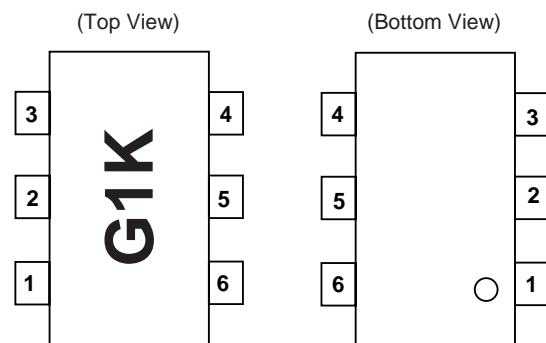

UPG154TB

OUTLINE DIMENSIONS (Units in mm)

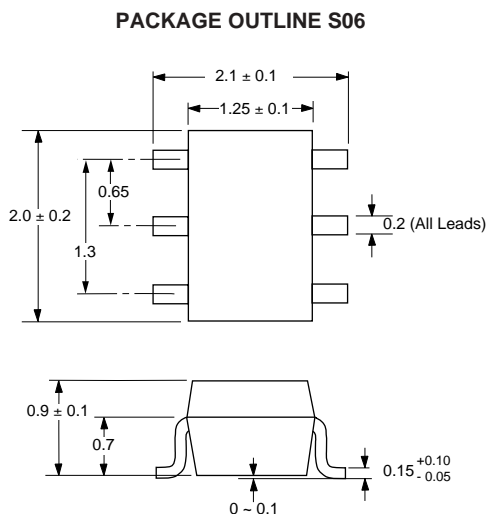

Note:
All dimensions are typical unless otherwise specified.

Life Support Applications

These NEC products are not intended for use in life support devices, appliances, or systems where the malfunction of these products can reasonably be expected to result in personal injury. The customers of CEL using or selling these products for use in such applications do so at their own risk and agree to fully indemnify CEL for all damages resulting from such improper use or sale.

ORDERING INFORMATION

PART NUMBER	QUANTITY
UPG154TB-E3	3 kpcs/Reel

Note:
Embossed Tape, 8 mm wide,
Pins 1, 2, 3 face tape perforation side.

EXCLUSIVE NORTH AMERICAN AGENT FOR **NEC** RF, MICROWAVE & OPTOELECTRONIC SEMICONDUCTORS

CEL CALIFORNIA EASTERN LABORATORIES • Headquarters • 4590 Patrick Henry Drive • Santa Clara, CA 95054-1817 • (408) 988-3500 • Telex 34-6393 • FAX (408) 988-0279
DATA SUBJECT TO CHANGE WITHOUT NOTICE

Internet: <http://WWW.CEL.COM>

12/7/2001