HA16117F Series

CMOS Watchdog Timer

HITACHI

Description

The HA16117F Series of ICs make a micro-processor (MPU) system fail-safe by monitoring its power supply to detect voltage drops, and monitoring a P-RUN (program running) pulse to detect system crashes. Also referred to as watchdog timers, these devices are essential in systems that aim for high levels of crash protection. Fabricated by a CMOS process, they consume little power and are ideally suited for battery-operated systems.

These ICs are available in versions for industrial and communications equipment and automotive applications, as well as for consumer products.

Functions

- Power-on reset
 - Sends a $\overline{\text{RES}}$ signal to the MPU for a fixed time at power-on
- Watchdog timer (WDT)
 - Monitors a P-RUN signal from the MPU and sends the MPU a $\overline{\text{RES}}$ signal if P-RUN departs from a set frequency range
- Auto-reset
 - Outputs $\overline{\text{RES}}$ signals to the MPU at clocked intervals while P-RUN remains abnormal
- Supply voltage supervision
 - Outputs a low $\overline{\text{RES}}$ signal if the supply voltage (same as the MPU's V_{CC}) falls below a low threshold level (V_{TL}). The threshold differs for different ICs in the series, allowing designers to choose an IC matching system requirements (see ordering information)

Features

- Low power consumption : Operating (ACC pin low) = 0.5 mW (Typ)
: Standby (ACC pin high) = 0.2 mW (Typ)
- Watchdog timer on/off control by ACC input signal
- Independent auto-reset high and low times (t_{RH} and t_{RL})
- Watchdog monitoring by frequency filtering (independent of duty cycle)
- High-precision low voltage detection ($\pm 2\%$)
- Space- and weight-saving 8-pin SOP package



HA16117F Series

Ordering Information

The HA16117F Series includes three ICs with different low threshold levels (V_{TL}).

Type No.	Low Threshold Voltage (V_{TL})
HA16117FPA/FPAJ	4.4 V Typ
HA16117FPB/FPBJ	4.2 V Typ
HA16117FPC/FPCJ	4.0 V Typ

Pin Arrangement

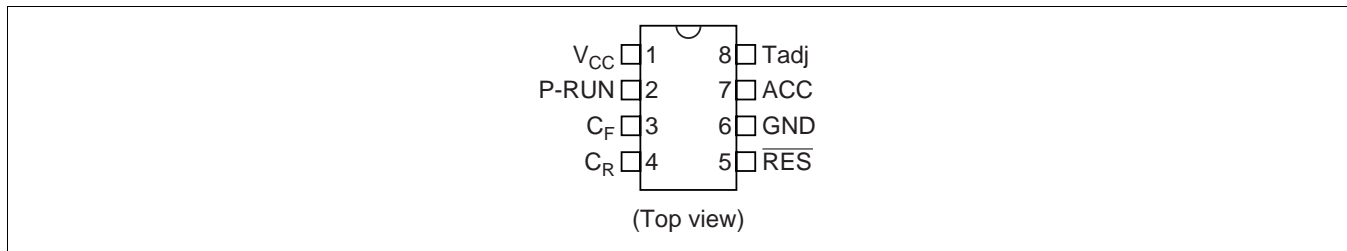

Pin Description

Pin No.	Symbol	Function
1	V_{CC}	Power supply voltage input
2	P-RUN	Watchdog timer (WDT) input
3	C_F	Connected capacitor C_F determines WDT filter characteristic (normal frequency range)
4	C_R	Connected capacitor C_R determines t_{ON} for power-on reset and t_{OFF} , t_{RH} , and t_{RL} for auto-reset
5	\overline{RES}	Reset signal output from WDT and voltage supervision circuits
6	GND	Ground
7	ACC	WDT on/off control input (on when ACC is low)
8	Tadj *	For adjusting t_{RH} and t_{OFF} (divide V_{CC} to get the adjustment voltage)

Note: The low-voltage threshold cannot be modified by changing the external resistors connected to the Tadj pin.

Block Diagram

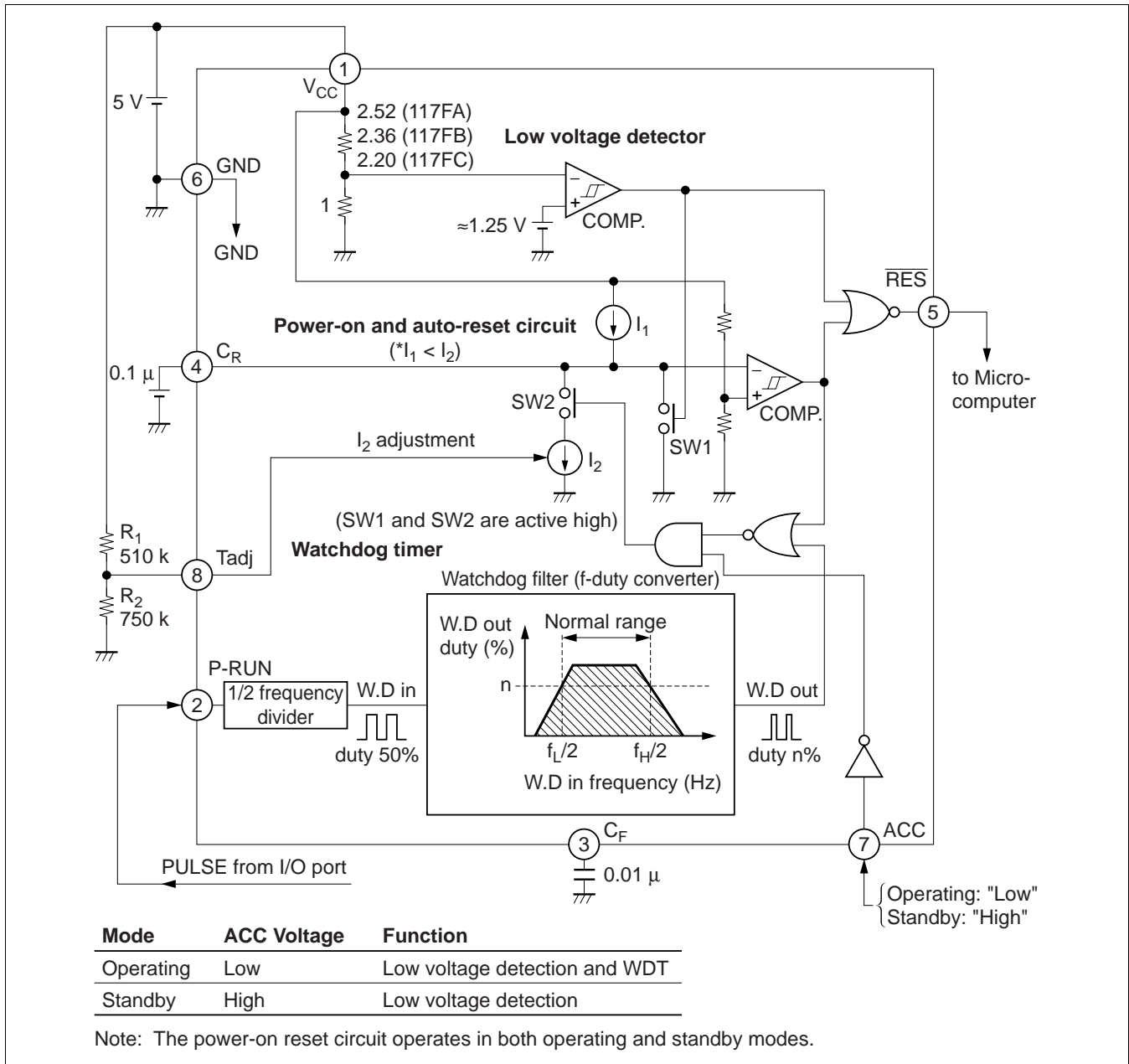

The HA16117F consists of a low voltage detector, power-on and auto-reset circuit, and watchdog timer.

Low Voltage Detector

Uses a reference voltage source ($\approx 1.25\text{ V}$) and high-precision comparator to detect drops in the supply voltage.

Power-On and Auto-Reset Circuit

Generates the $\overline{\text{RES}}$ waveform, using a multivibrator consisting of a current source I_1 that charges the external capacitor C_R , a current source I_2 that discharges C_R , and a comparator.

Watchdog Timer

Reshapes the P-RUN signal (programming-running pulse) from the MPU to obtain a 50% duty cycle, then converts frequency to duty cycle in the watchdog filter (WD filter).

The watchdog filter is a bandpass filter. The duty cycle of the filter output is highest in the normal frequency range of P-RUN.

The watchdog filter output controls I_2 in the multivibrator, the higher the duty cycle of the watchdog filter output, the shorter the time during which I_2 discharges C_R . If the duty cycle is high enough then C_R is held at a high potential, preventing the multivibrator from firing, and the \overline{RES} output remains high.

Absolute Maximum Ratings (Ta = 25°C)

Item	Symbol	Ratings		Unit
		HA16117FPA/FPB/FPC	HA16117FPAJ/FPBJ/FPCJ	
Power supply voltage	V_{CC}	-0.3 to +14	-0.3 to +14	V
P-RUN input voltage	V_P	V_{CC}	V_{CC}	V
ACC input voltage	V_{ACC}	14	14	V
RES output current	I_{RES}	10	10	mA
Permissible dissipation *1	P_T	300	300	mW
Operating temperature range	Topr	-30 to +85	-40 to +85	°C
Storage temperature	Tstg	-55 to +125	-55 to +125	°C

Note: 1. This is the value when mounted on a glass epoxy substrate with 30% wiring density, up to an ambient temperature of 83°C. Above that temperature, derate by 7.14 mW/°C.

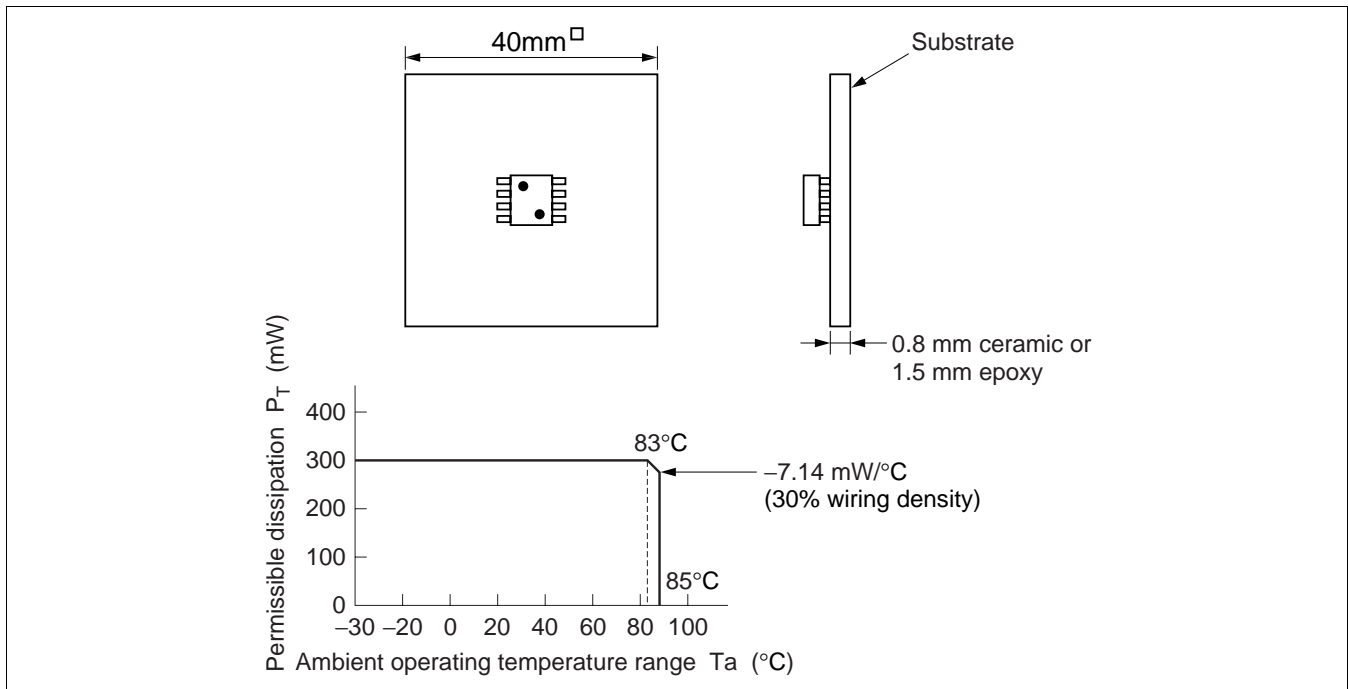

Electrical Characteristics

($V_{CC} = 5\text{ V}$, $T_a = 25^\circ\text{C}$, $C_F = 0.01\ \mu\text{F}$, $C_R = 0.1\ \mu\text{F}$, $R_1 = 510\ \text{k}\Omega$, $R_2 = 750\ \text{k}\Omega$)

Item		Symbol	Min	Typ	Max	Unit	Test Conditions	
General	Operating supply current	I_{CC1}	—	100	—	μA	$V_{ACC} = 0\text{ V}$, $f_{P-RUN} = 100\text{ Hz}$	
		I_{CC2}	—	200	600	μA	$V_{ACC} = 0\text{ V}$, $f_{P-RUN} = 20\text{ kHz}$	
	Standby supply current	I_{STBY}	—	43	100	μA	$V_{ACC} = 12\text{ V}$	
Low voltage detector	Low voltage threshold level	HA16117FPA/FPAJ	V_{TL}	4.3	4.4	4.5	V	When V_{CC} drops ↓
		HA16117FPB/FPBJ		4.1	4.2	4.3	V	
		HA16117FPC/FPCJ		3.9	4.0	4.1	V	
	Hysteresis width	V_{HYS}	50	100	150	mV		
ACC	Low input voltage	V_{IL1}	—	—	0.8	V		
	High input voltage	V_{IH1}	2.0	—	—	V		
P-RUN input	Low input voltage	V_{IL2}	—	—	0.8	V		
	High input voltage	V_{IH2}	2.0	—	—	V		
WDT	Power-on reset time	t_{ON}	24	40	56	ms		
	Reset-clock off time	t_{OFF}^{*1}	78	130	182	ms		
	Reset low time	t_{RL}	12	20	28	ms		
	Reset high time	t_{RH}	36	60	84	ms	P-RUN pin = 0 V	
	Low setup time	t_{SL}	1	—	—	ms		
	High setup time	t_{SH}	—	—	1	ms		
$\overline{\text{RES}}$ output	$\overline{\text{RES}}$ low voltage	V_{OL}	—	—	0.4	V	$I_{OL} = 1\text{ mA}$	
	$\overline{\text{RES}}$ high voltage	V_{OH}	—	V_{CC}	—	V	Open	
	Reset function starting voltage	V_{RES}	—	0.8	1.4	V		
Constant range	Constant range of R_1 and R_2	K	0.55	0.6	0.8	—	$K = R_2 / (R_1 + R_2)$	
	Operating supply voltage range	V_{CCRNG}	V_{TL}	—	6.0	V		

Note: 1. Reset-clock off time t_{OFF} is provided as shown in the under figure.

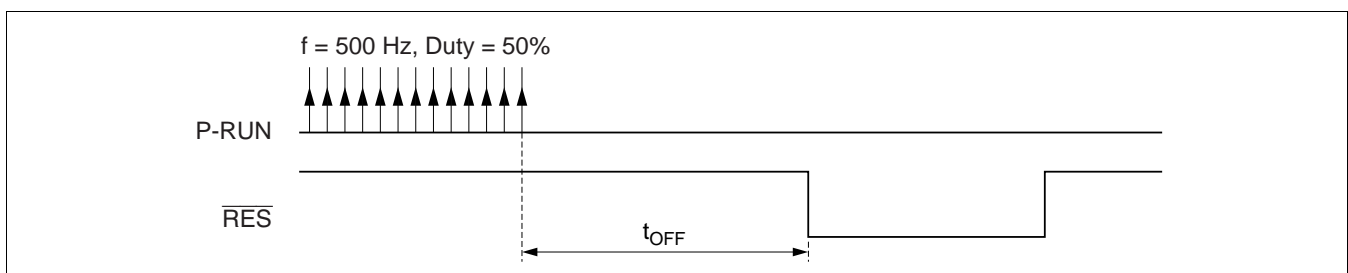

Timing Waveforms and Functional Description

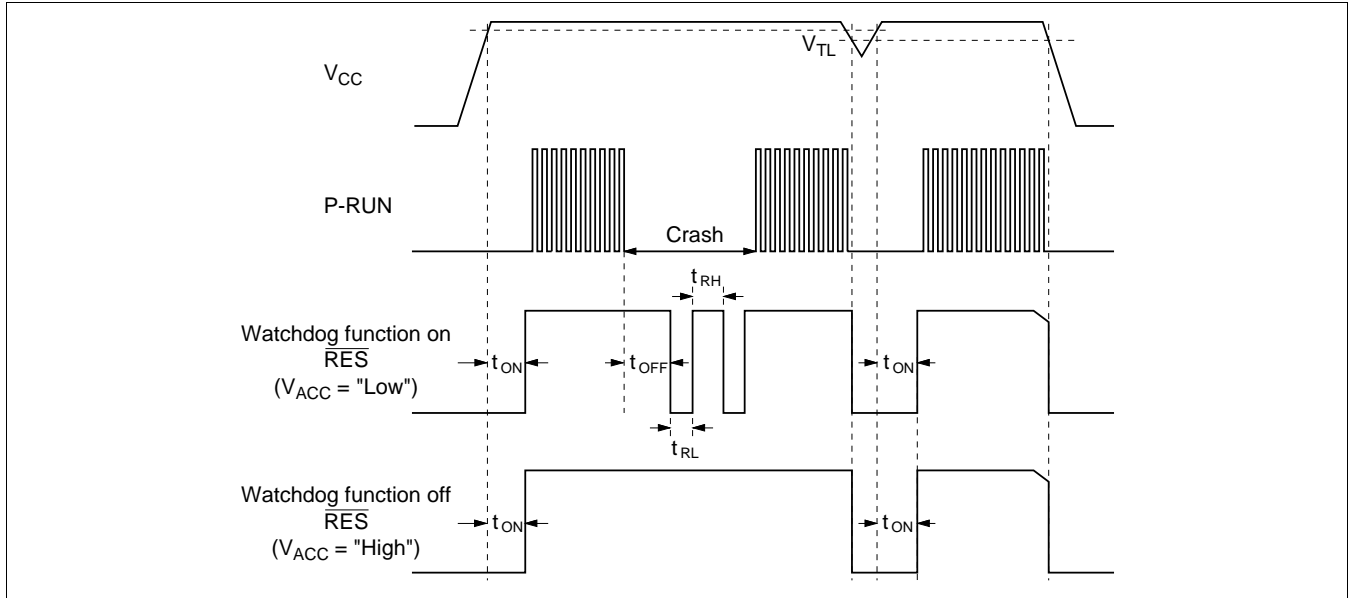

Figure 1 Timing Waveforms

Watchdog On/Off Function

A feature of the HA16117F is that watchdog supervision can be switched on and off. When the watchdog function is switched on, both the supply voltage and

P-RUN input are monitored to detect abnormal conditions. When the watchdog function is switched off (standby mode), only the supply voltage is monitored. Watchdog supervision is switched on and off by the input at the ACC pin (pin 7): Supervision is on when ACC is low, and off when ACC is high.

Many MPUs have a standby mode in which the CPU stops running but memory contents are retained. In standby mode, program execution halts and I/O ports go to the high-impedance state, so there is no need for the watchdog timer to supervise pulse output from an I/O port to detect abnormal conditions. Power can be saved by placing both the MPU and HA16117F in standby mode at the same time. The HA16117F is designed to draw a typical standby current I_{STBY} of only 43 μA Typ when the watchdog function is switched off.

ACC Pin (pin 7) and $\overline{\text{RES}}$ Output

When the MPU returns from standby mode to normal operation it generally takes 10 to 200 ms for the clock oscillator in the MPU to stabilize. The $\overline{\text{RES}}$ signal is not output during this setup time. After the setup time (t_{SL}) has elapsed, $\overline{\text{RES}}$ is output if the P-RUN signal from the MPU is still abnormal.

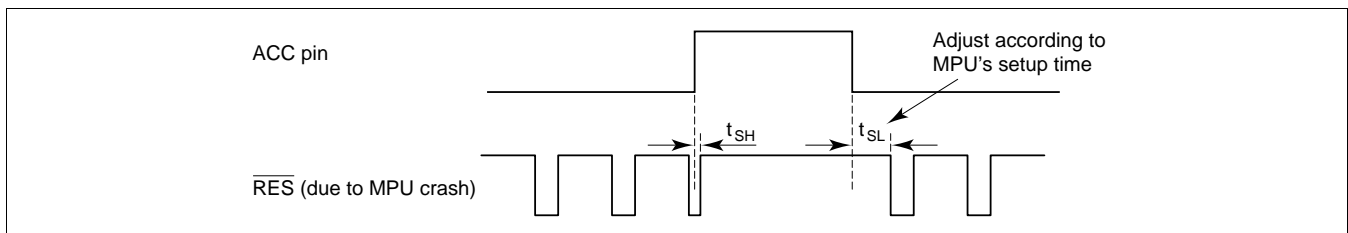

Figure 2 ACC Pin and $\overline{\text{RES}}$ Output

Internal Operation and Usage Notes

Figure 3 shows an equivalent circuit of the watchdog timer block with a V_{CC} pin level of 5 V and ACC pin level of 0 V, and the following pages show internal operation timing charts for different P-RUN frequencies. (Descriptions apply to conditions $C_F = 0.01 \mu\text{F}$, $C_R = 0.1 \mu\text{F}$, $R_2/(R_1 + R_2) = 0.6$.)

Operation

The power-on and auto-reset circuit is a multivibrator with timing controlled by C_R charge current I_1 and discharge current I_2 . As $I_1 : I_2 \approx 3 : 1$ (Typ design value), when the (WD) (watchdog filter circuit output) on-duty is 25% or above, the C_R pin potential does not fall below 1.6 V. Therefore, (C) in the figure below is fixed low, and $\overline{\text{RES}}$ is not output. The (WD) on-duty varies according to the P-RUN frequency. If the frequency is lower or higher than the design value, the (WD) on-duty decreases, and at 25% or below, $\overline{\text{RES}}$ is output. Refer to the timing charts on the following pages for an explanation of the operation of the watchdog filter.

Usage Notes

- When the P-RUN frequency reaches 20 kHz or above, t_{OFF} is short (see the timing charts on the following pages). This must be borne in mind in the design stage.
- If the P-RUN frequency fluctuates, $\overline{\text{RES}}$ may also be output within the normal detection set frequency (see the timing charts on the following pages).
- Detection frequencies f_H and f_L described in the Data Book are Typ values, and a certain amount of dispersion can be expected. A margin of $\pm 30\%$ or more should be allowed for in the design.

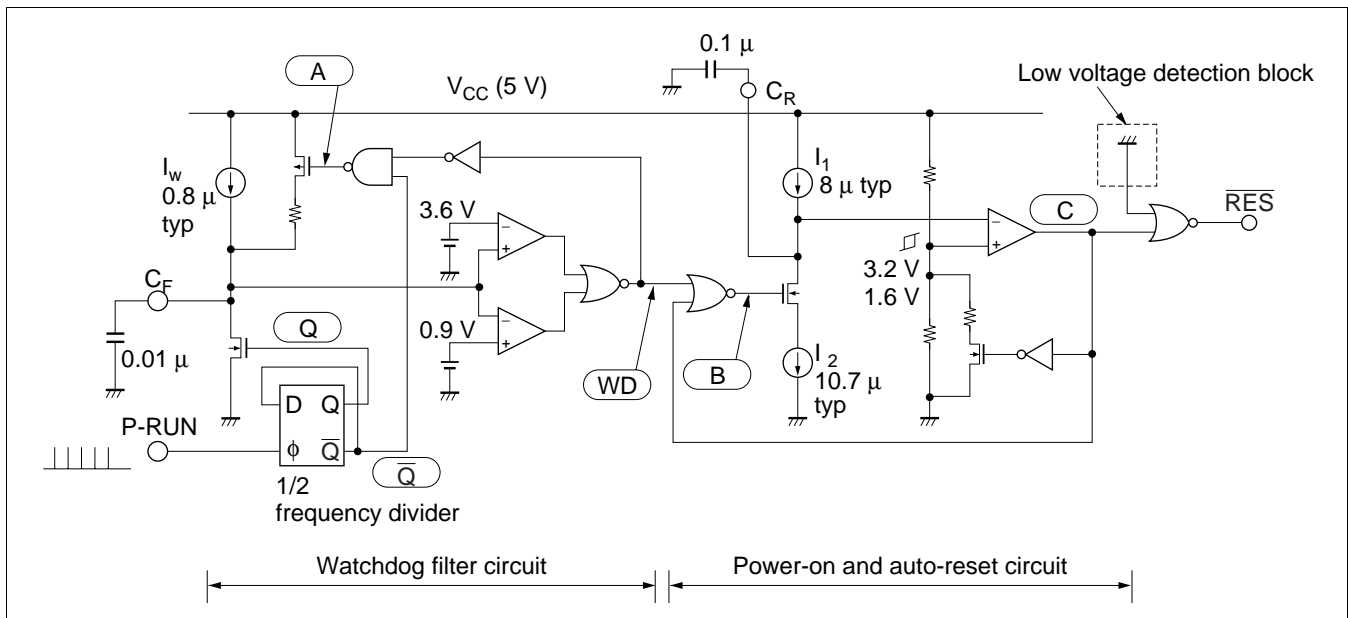
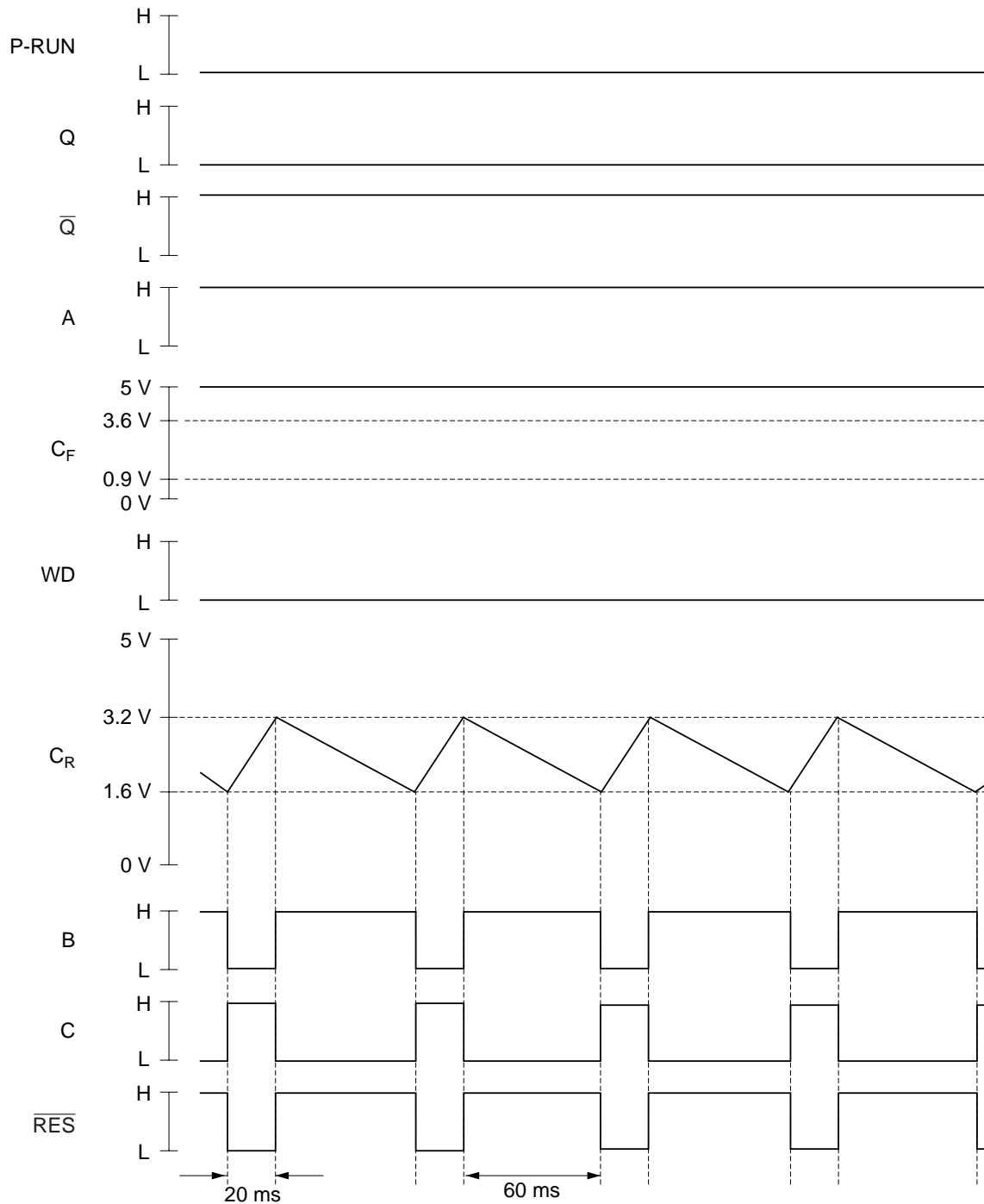

Figure 3 Watchdog Timer Evaluation Circuit

1. When P-RUN signal is not input

The watchdog filter circuit output (WD) is fixed low, so the $\overline{\text{RES}}$ signal is output as shown in the figure below in accordance with power-on and auto-reset circuit C_R charge/discharge.



2. With a low-frequency P-RUN signal (13 Hz to 26 Hz)

When f_{P-RUN} is 13 Hz to 26 Hz, the WD duty ($D = 100 \times t_2/2T$) is 25% to 50%. When the WD duty is 25% or above, multivibrator (power-on and auto-reset circuit) oscillation stops. As a result, the RES signal is fixed high.

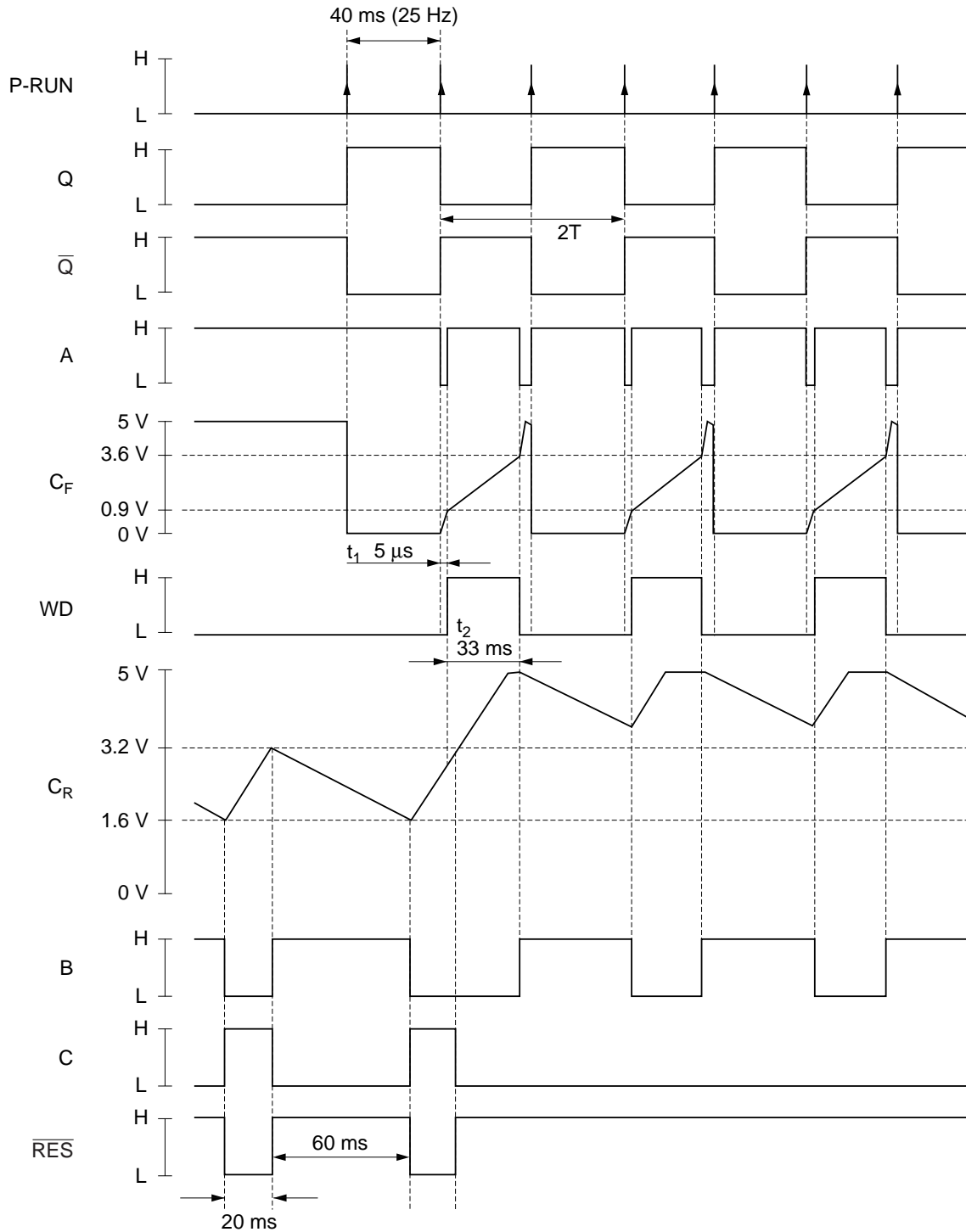

3. With a 10 kHz P-RUN signal

When f_{P-RUN} is 10 kHz, the WD duty ($D = 100 \times (T - t_2)/2T$) is 48%. As the duty is above 25%, the multivibrator (power-on and auto-reset circuit) does not oscillate. The \overline{RES} signal remains high.

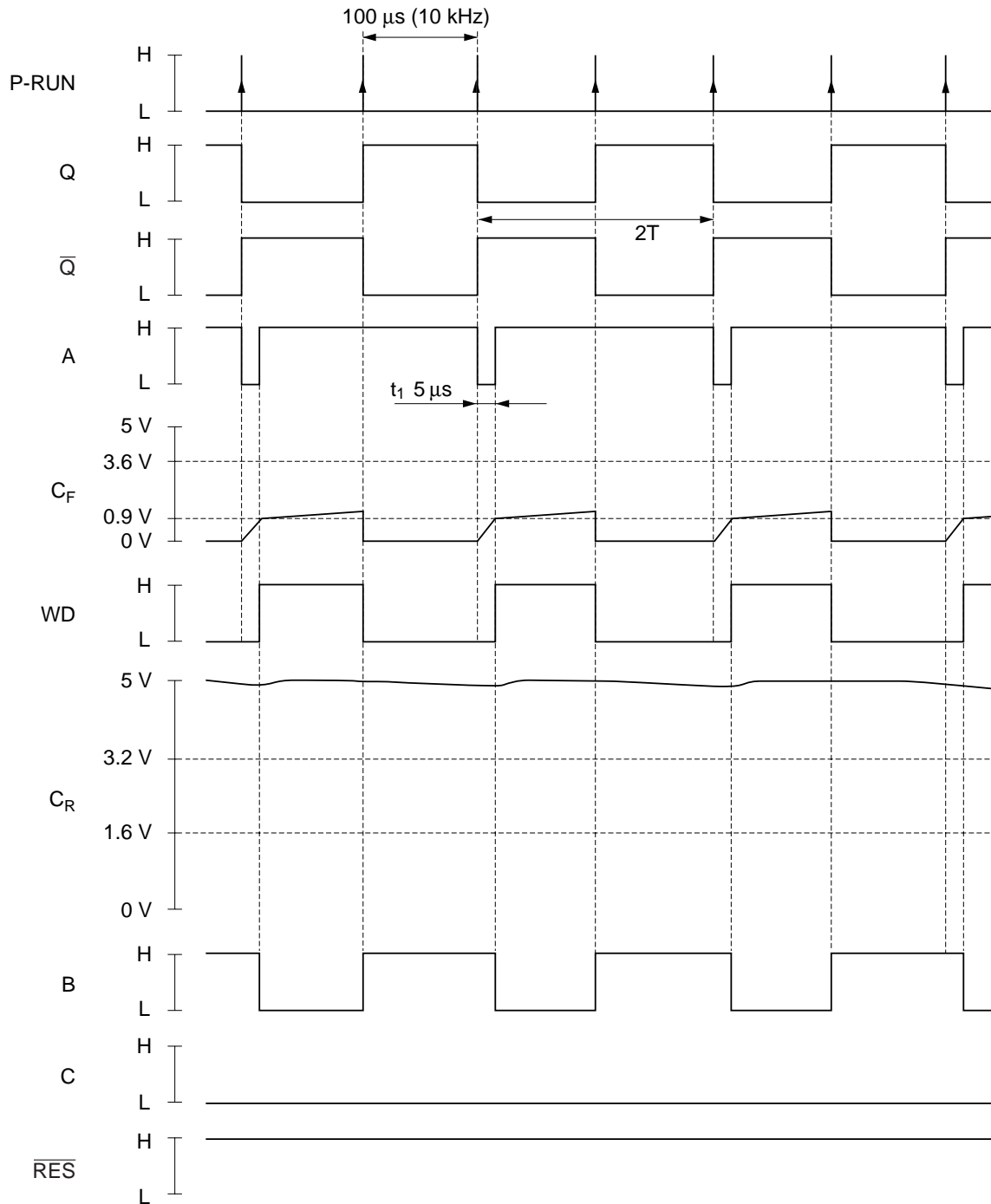

4. With a 150 kHz P-RUN signal

When f_{P-RUN} is 100 kHz or above, the WD duty ($D = 100 \times (T - t_2)/2T$) is 25% or below. Therefore, C_R is discharged, and the \overline{RES} signal is output at the instant that the pin potential falls to the comparator circuit threshold value ($V_{TL} = 1.6 V$).

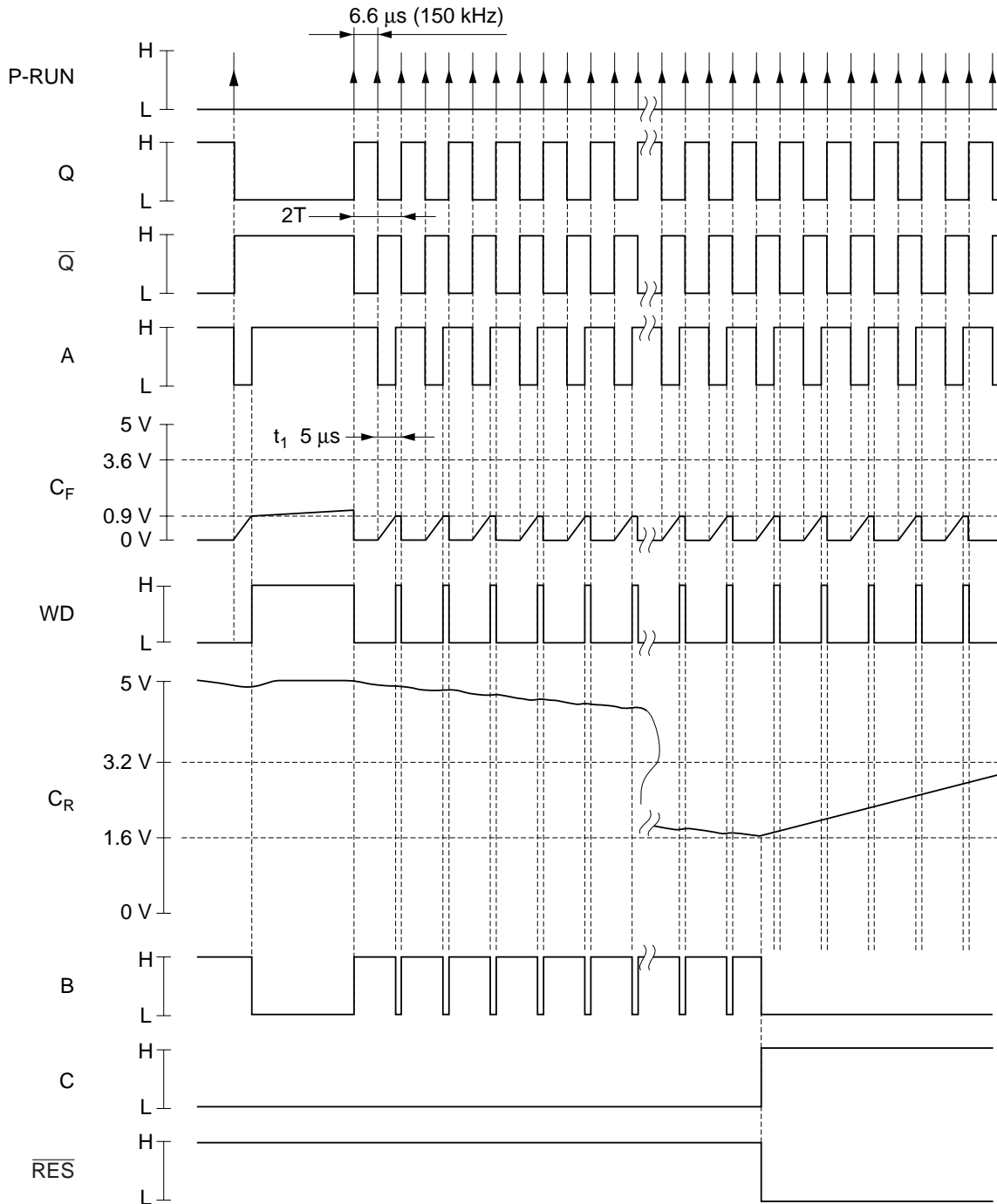

5. t_{OFF} when P-RUN signal 90 kHz

When the P-RUN frequency is high, even though within specification, the C_R pin potential falls. If the P-RUN frequency falls sharply at this time, t_{OFF} may be short. With values of $C_F = 0.01 \mu\text{F}$ and $C_R = 0.1 \mu\text{F}$, the C_R pin potential will not fall as long as the P-RUN frequency is 20 kHz or below.

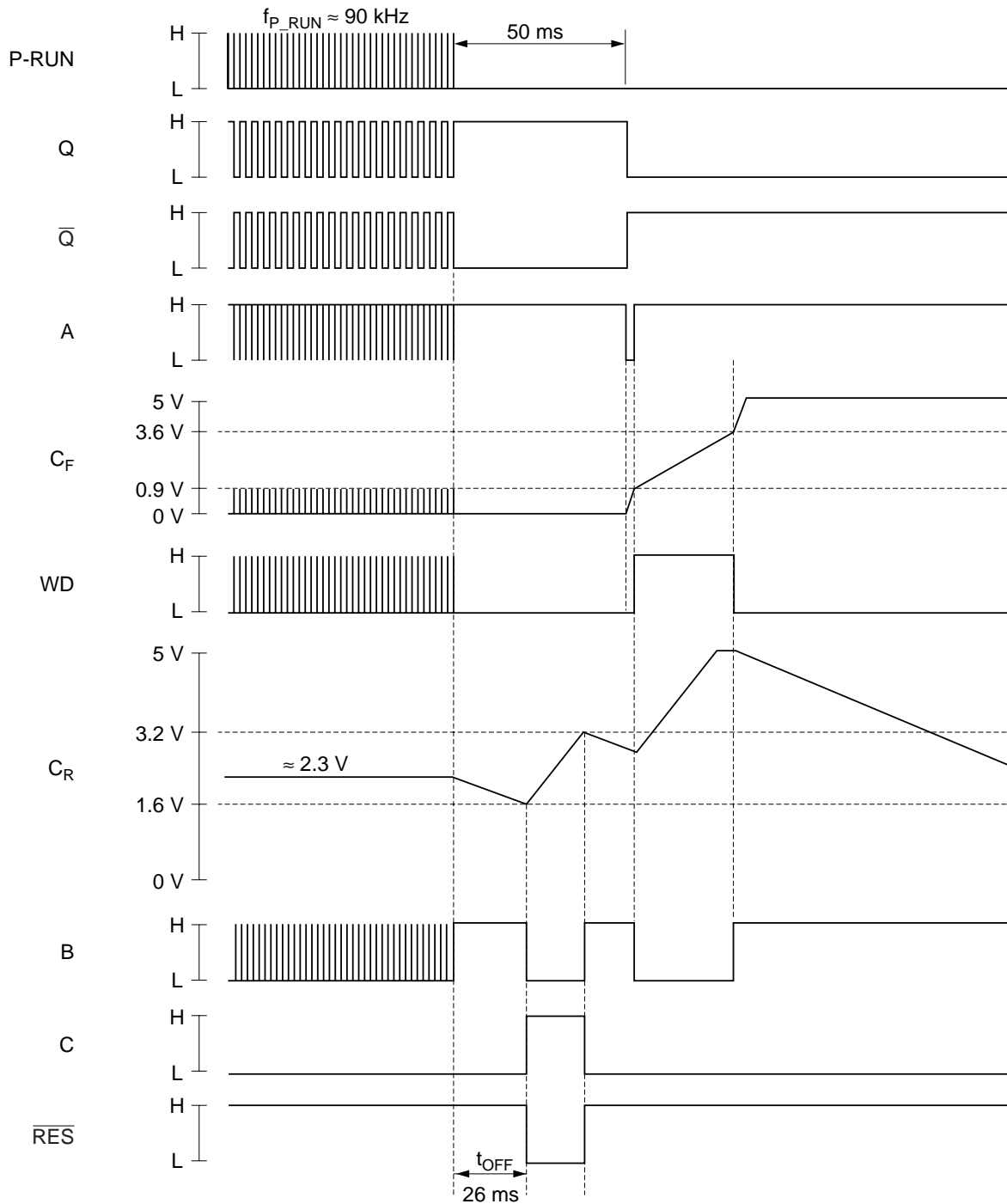

6. When P-RUN frequency fluctuates (1)

If there is a double-pulse in P-RUN, the WD filter duty will be decreased and $\overline{\text{RES}}$ will be output, as shown in the figure below, for example. In this case, the condition for non-output of the $\overline{\text{RES}}$ signal is a value of 3 or less for the ratio of P-RUN pulse interval minimum value to maximum value (when $f_{\text{P-RUN}} \leq 20 \text{ kHz}$). This is because the C_{R} pin charge/discharge current ratio is 3.

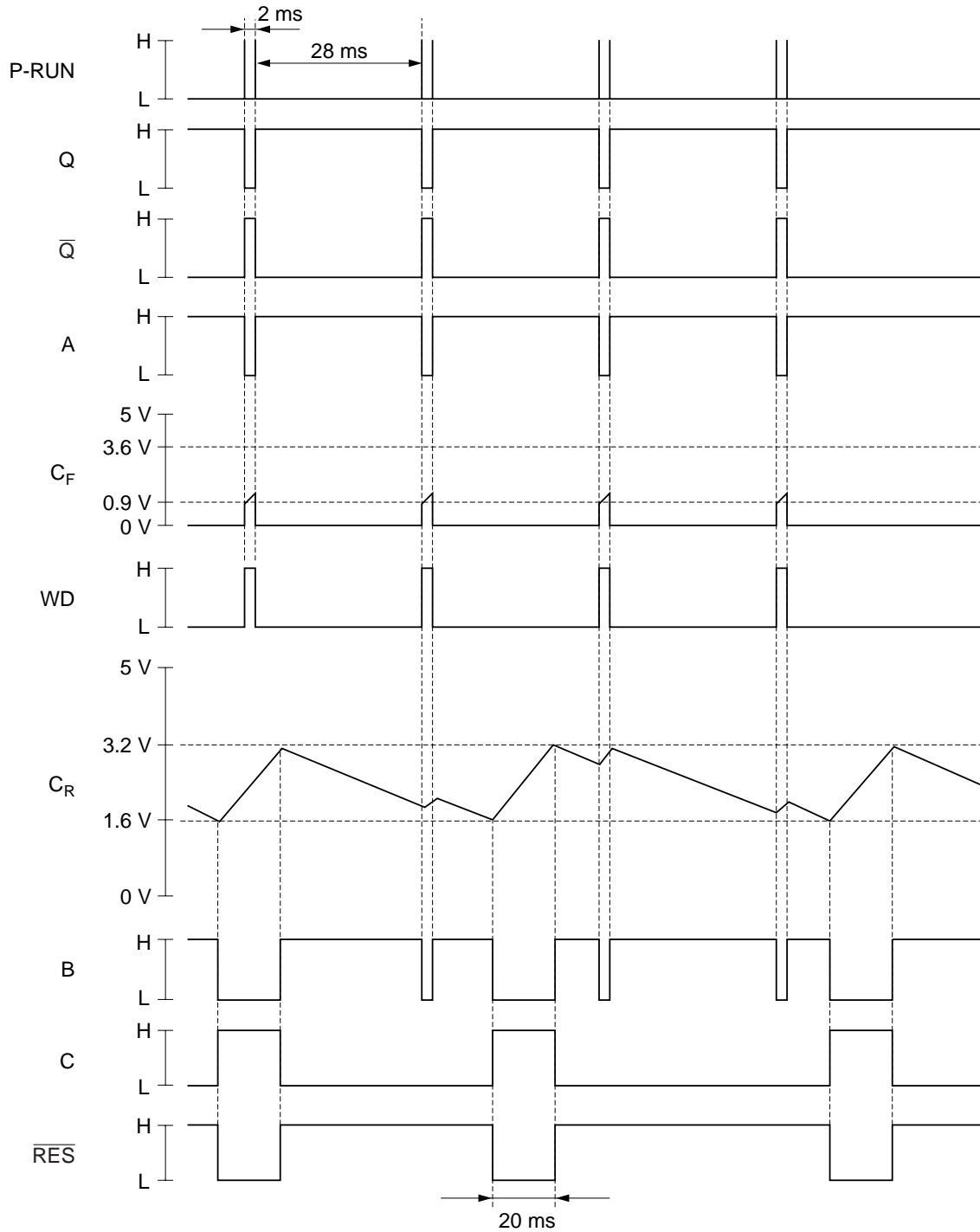

7. When P-RUN frequency fluctuates (2)

If there is a double-pulse in P-RUN, $\overline{\text{RES}}$ will not be output as long as the ratio of P-RUN pulse interval minimum value to maximum value is 3 or less. The timing chart for a P-RUN minimum interval of 8 ms and maximum interval of 22 ms is shown below.

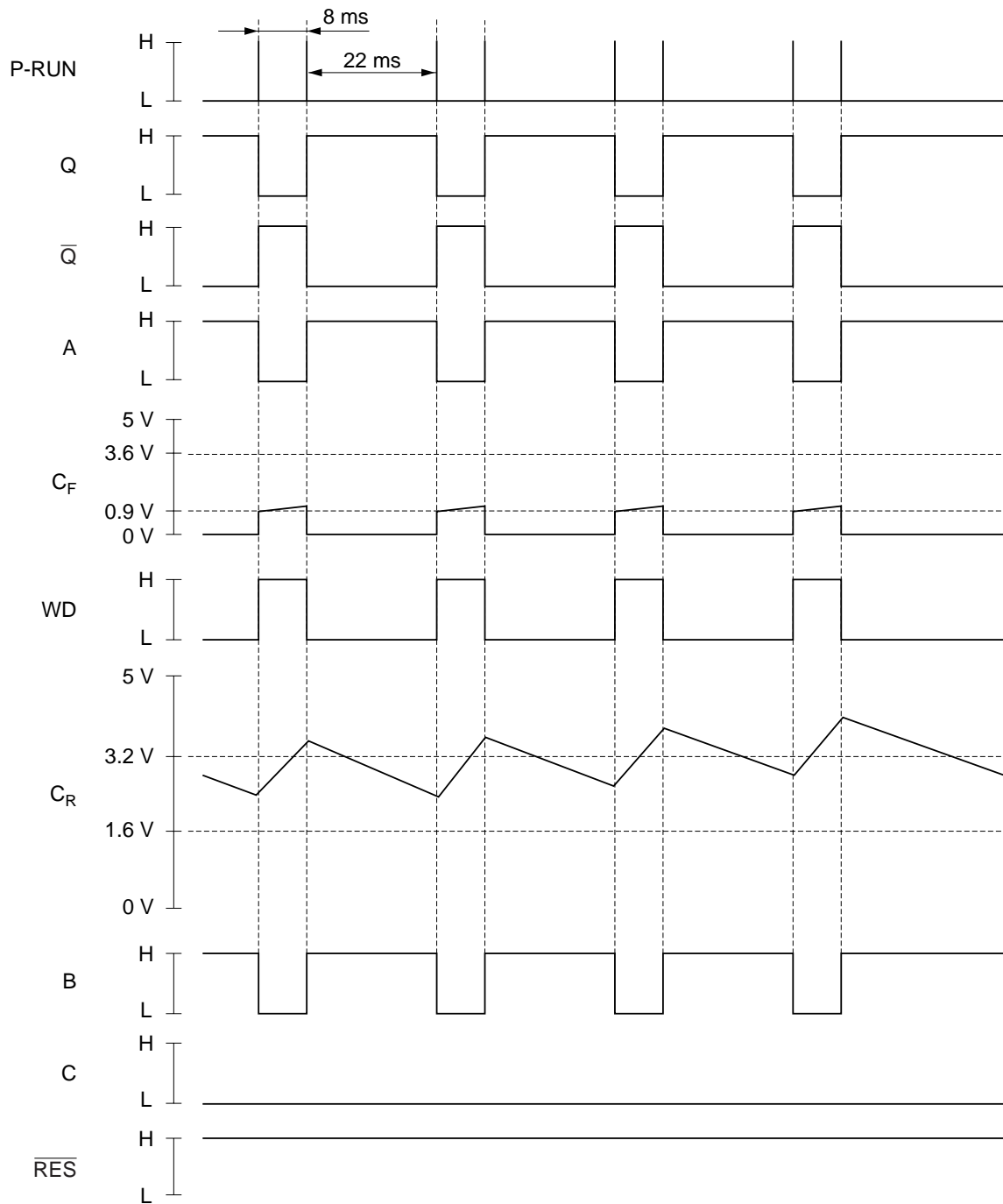

8. Summary of cases where P-RUN frequency fluctuates

If there is a double-pulse in P-RUN, \overline{RES} may be output if the double-pulse has multiple frequency components. If the P-RUN frequency fluctuates, refer to the following when making the P-RUN setting.

- P-RUN normal detection region, duty dependency

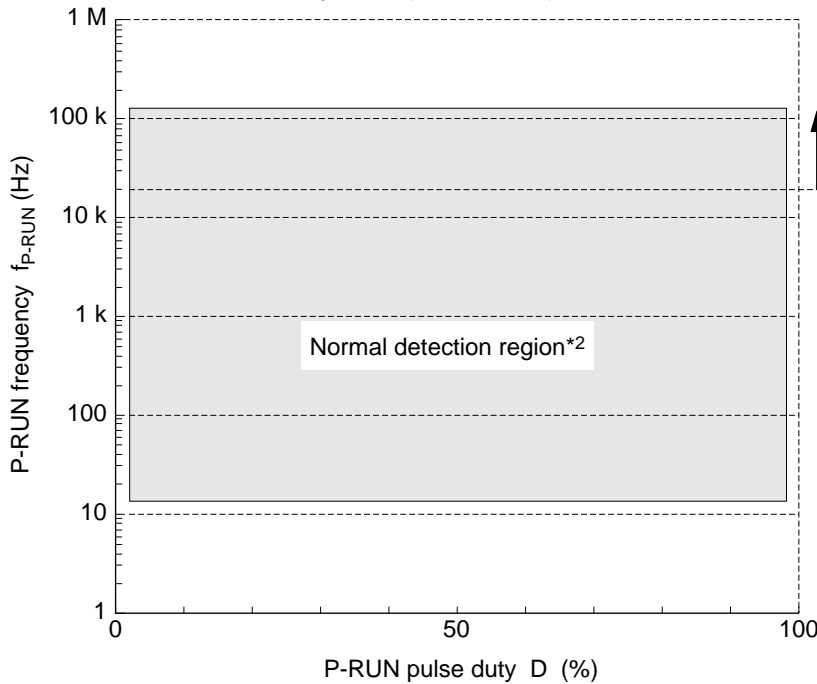

Note: 1
When $f_{P-RUN} \geq 20$ kHz, t_{OFF} is frequency-dependent, so care is required when making the P-RUN setting (see figure below).

Note: 2. This is the region when f_{P-RUN} is constant.
If f_{P-RUN} fluctuates within the normal detection region, the following applies:

Normal detection is performed when the condition $f_{P-RUN H}/f_{P-RUN L} < M$ is satisfied.

- f_{P-RUN} dependency of V_{CR} , t_{OFF} , M

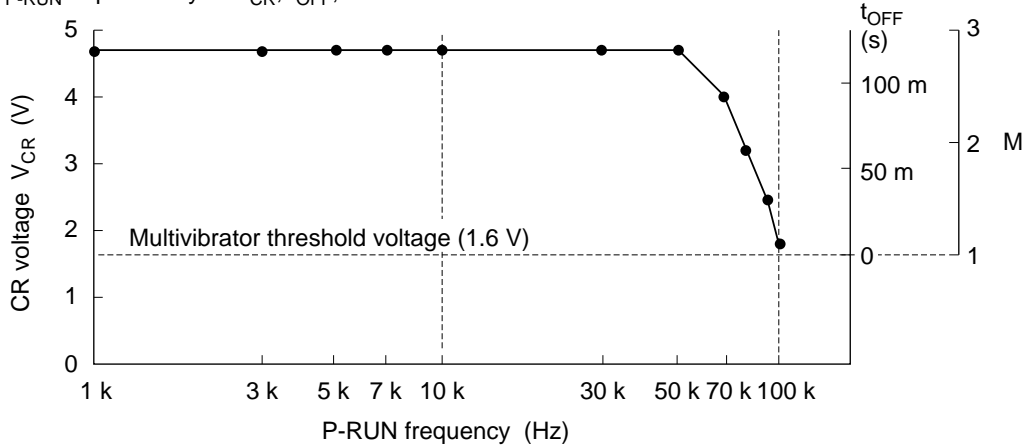

Setting of $\overline{\text{RES}}$ Timing and Watchdog Frequency Range

Different MPUs have different $\overline{\text{RES}}$ timing requirements. The minimum reset time (t_{ON}) required at power-on (rise of V_{CC}) is 20 ms for some MPUs and 100 ms for others.

$\overline{\text{RES}}$ timing waveform parameters must be selected according to the MPU. With the HA16117F the timing of the $\overline{\text{RES}}$ output and the watchdog frequency range can both be set by external constants (C_{F} , C_{R} , and K).

Item	Symbol	Parameters		
		CR (pin 4)	CF (pin 3)	K (pin 8) *1
Power-on reset time	t_{ON}	●		
Reset-clock off time	t_{OFF}	●	▲ *2	●
Reset low time	t_{RL}	●		
Reset high time	t_{RH}	●		●
Watchdog frequency high	f_{H}		●	●
Watchdog frequency low	f_{L}	●	●	●

Notes: 1. $K = R_2 / (R_1 + R_2)$

2. Variability of t_{OFF} increases with increasing C_{F} . The variability Δt_{OFF} is approximately $3.3 (\text{M}\Omega) \times C_{\text{F}} (\mu\text{F})$, so $C_{\text{F}} \leq 0.01 (\mu\text{F})$ is recommended.

3. External constants should be selected with reference to the formulas in tables 1 and 2.

Table 1 Calculation of $\overline{\text{RES}}$ Output Timing

Item	Formula	Notes
t_{ON} (ms)	$400 (\Omega) \times C_{\text{R}} (\mu\text{F})$	t_{ON} and t_{OFF} can be set independently
t_{OFF} (ms)	$1.99 \times t_{\text{RH}}$ (ms)	
t_{RL} (ms)	$0.5 \times t_{\text{ON}}$ (ms)	t_{RL} and t_{RH} can be set independently
t_{RH} (ms)	$\frac{1.6 (\text{V})}{K \times 31 (\mu\text{A}) - 15.8 (\mu\text{A})} \times C_{\text{R}} (\mu\text{F}) \times 10^3$	
t_{SL} (ms)	$\approx t_{\text{OFF}}$ (ms)	

Table 2 Calculation of Watchdog Frequency Range

Item	Formula
f_{H} (MHz)	$\frac{1}{500 (\Omega) \times C_{\text{F}} (\mu\text{F})} \times \frac{t_{\text{RH}} (\text{ms}) - t_{\text{RL}} (\text{ms})}{t_{\text{RH}} (\text{ms}) + t_{\text{RL}} (\text{ms})}$
f_{L} (Hz)	$\frac{1}{1.7 (\text{M}\Omega) \times C_{\text{F}} (\mu\text{F})} \times \frac{t_{\text{RL}} (\text{ms})}{t_{\text{RH}} (\text{ms}) + t_{\text{RL}} (\text{ms})} \text{ or } \frac{1}{t_{\text{OFF}} (\text{ms})} \times 10^3$ Whichever is larger

Selection of External Constants

If the reset duration necessary for the MPU to operate reliably at power-on is known, there is a simple procedure for selecting external constants, starting from the power-on reset time (t_{ON}).

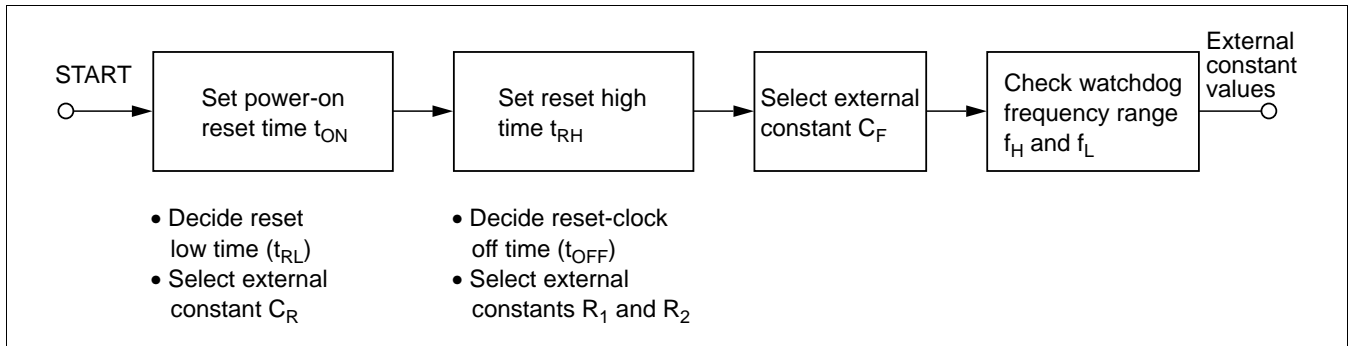
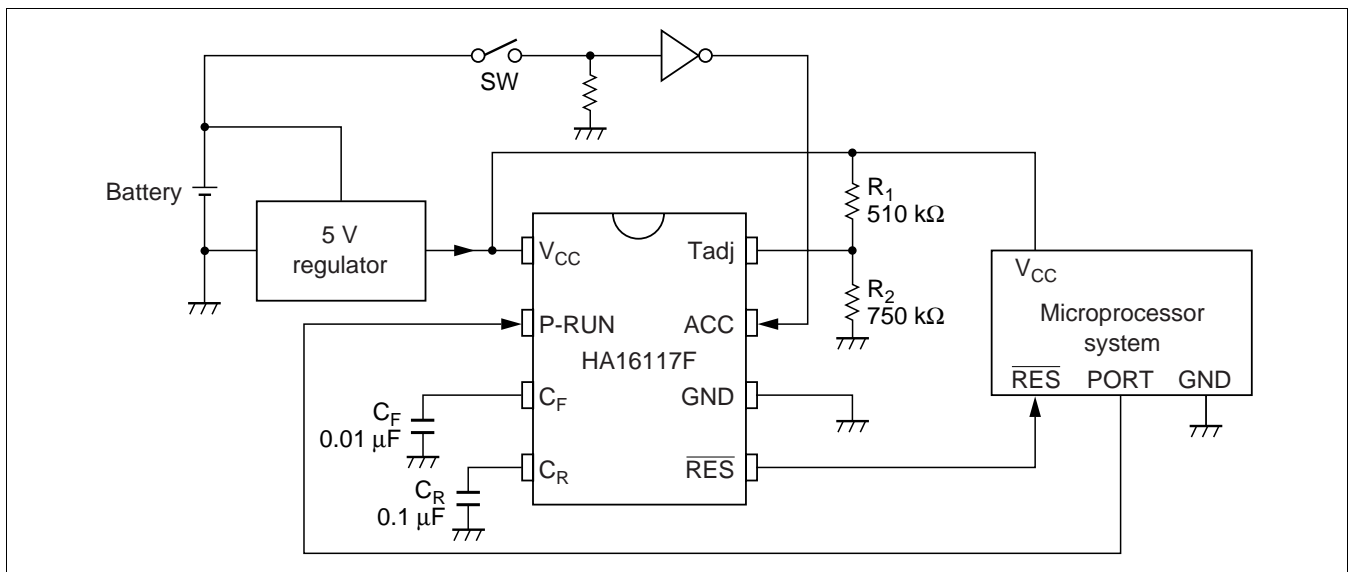
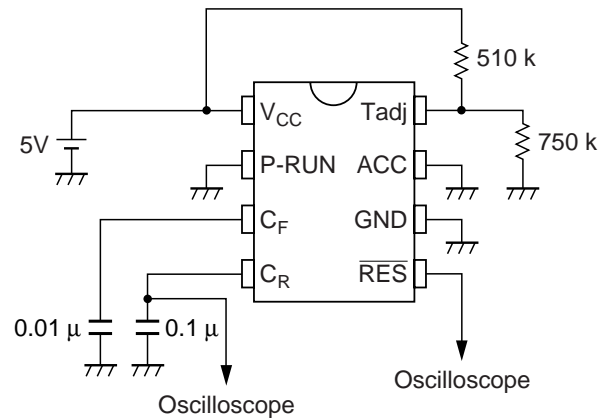
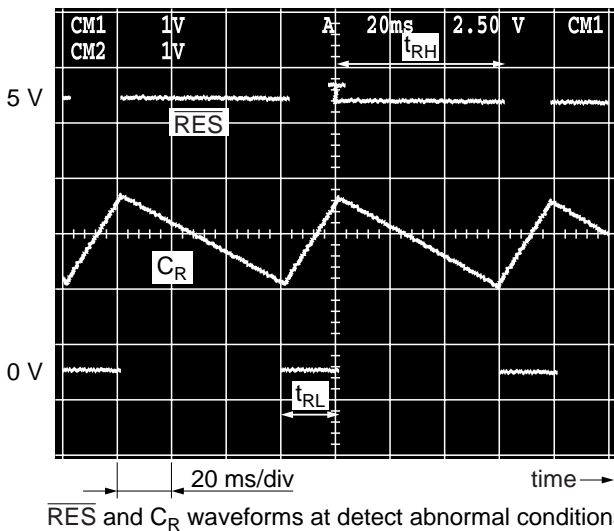
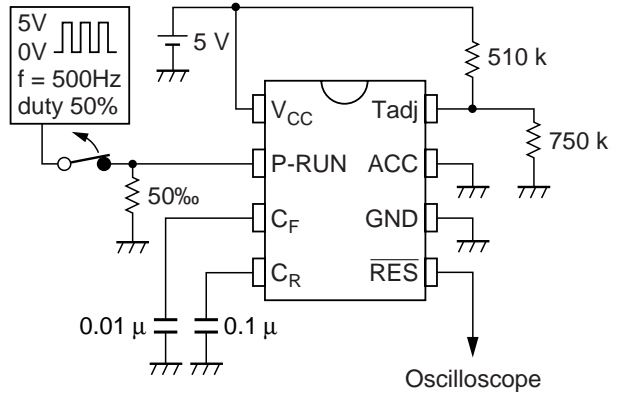
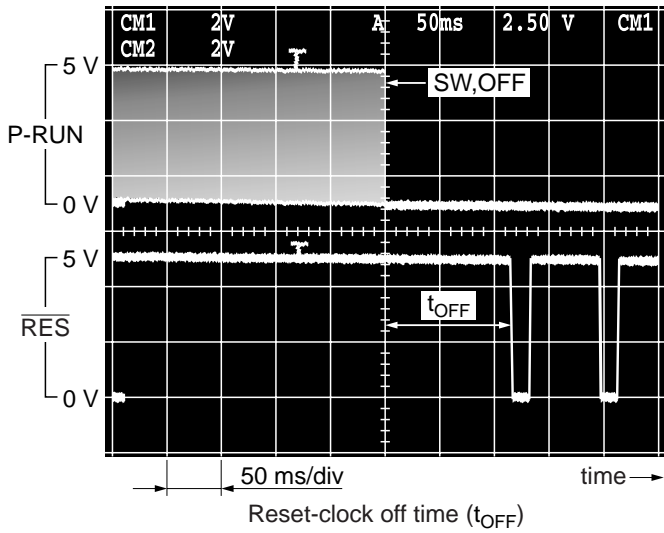
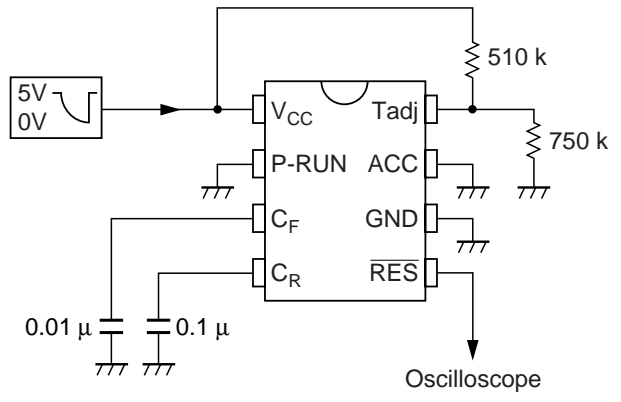
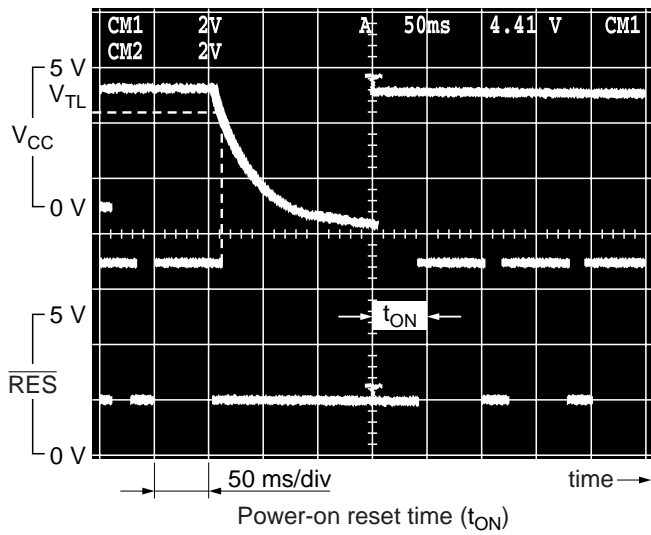

Figure 4 Procedure for Selecting External Constants

Application Example



Operating Characteristics and Test Circuits



Low Voltage Threshold vs. Ambient Temperature

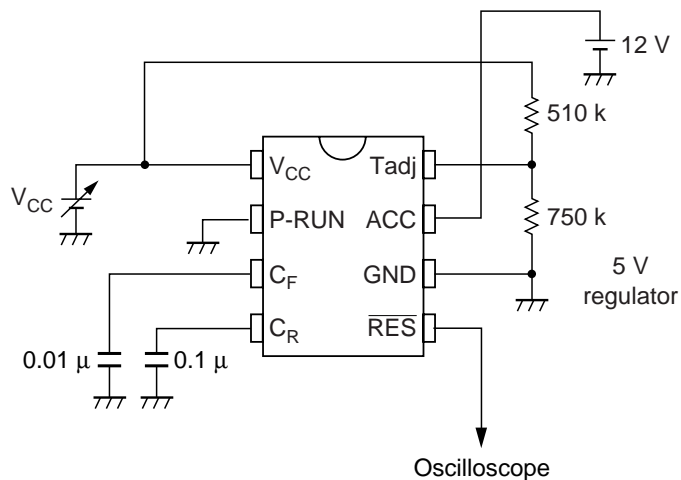
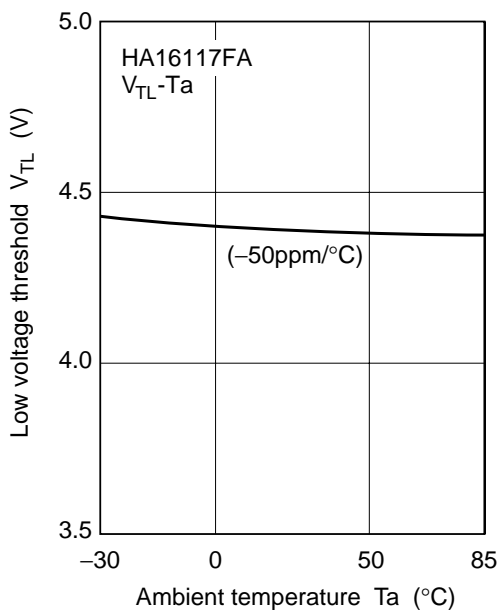

Threshold Hysteresis Width vs. Ambient Temperature

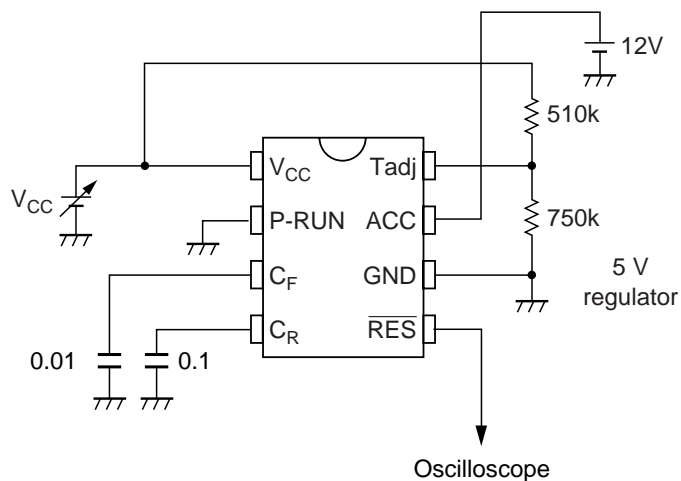
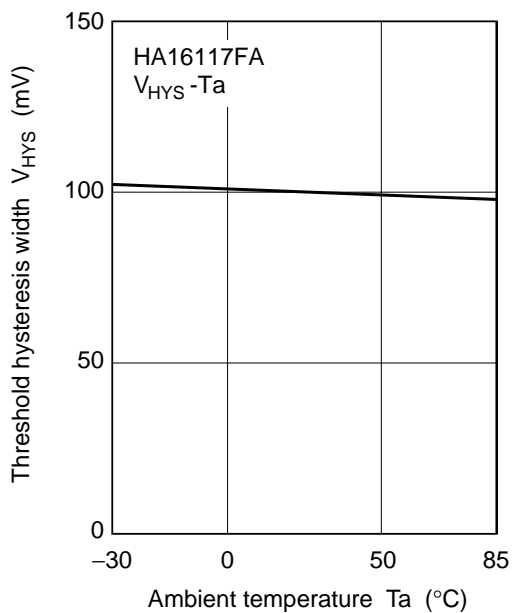

Operating Supply Current vs. P-RUN Input Frequency

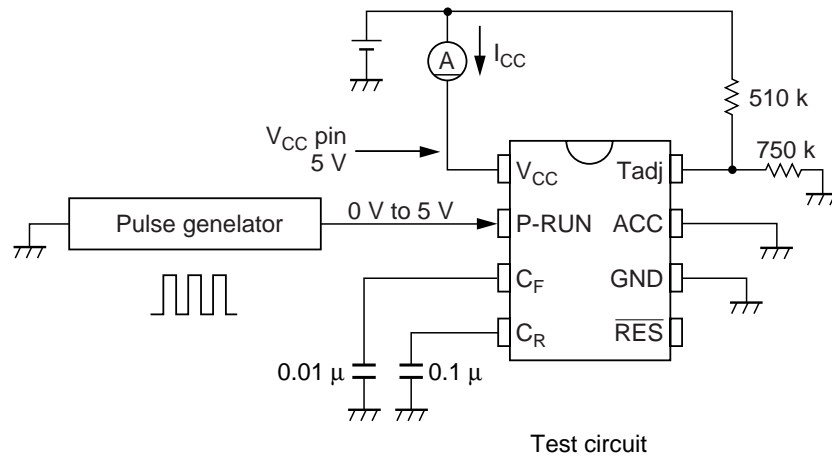
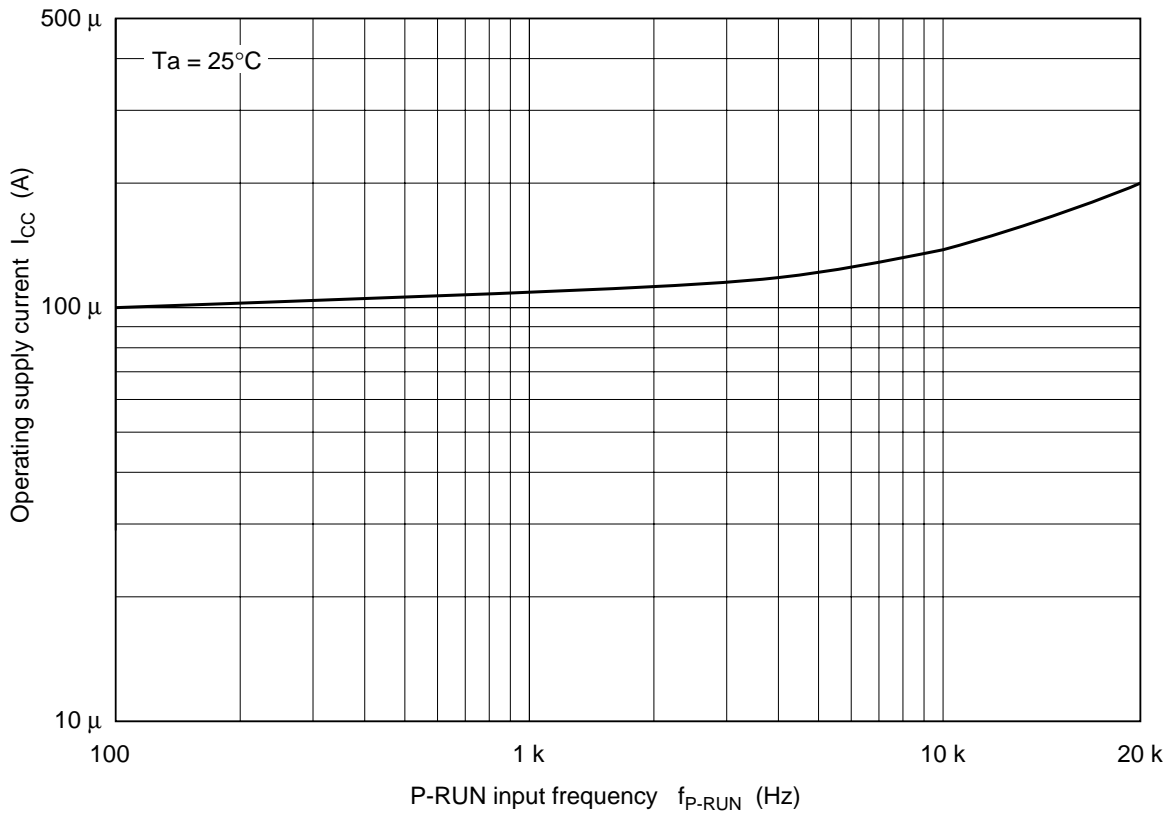

Standby Supply Current vs. Supply Voltage

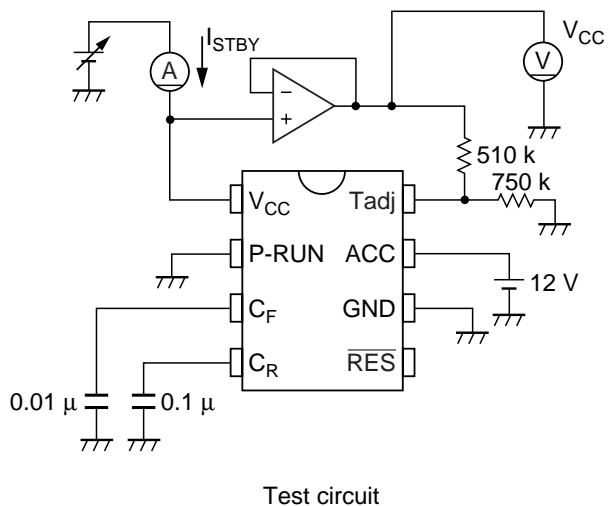
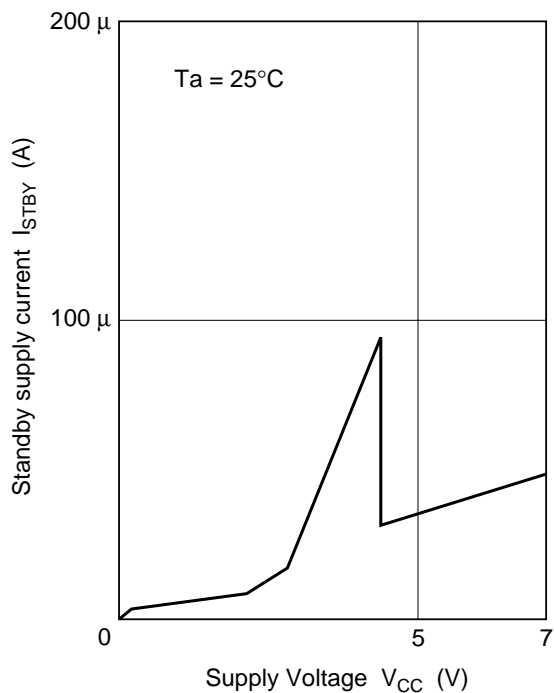

Supply Current vs. Ambient Temperature

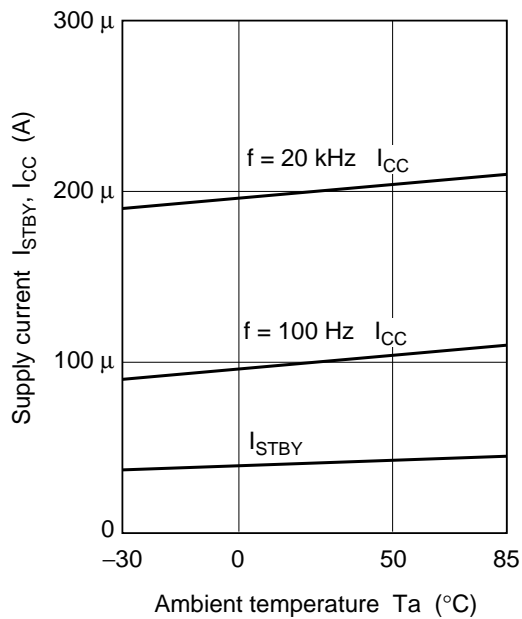

$\overline{\text{RES}}$ Low Voltage vs. $\overline{\text{RES}}$ pin Sink Current

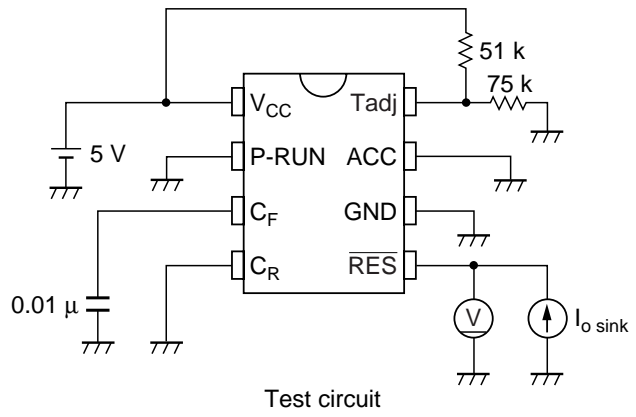
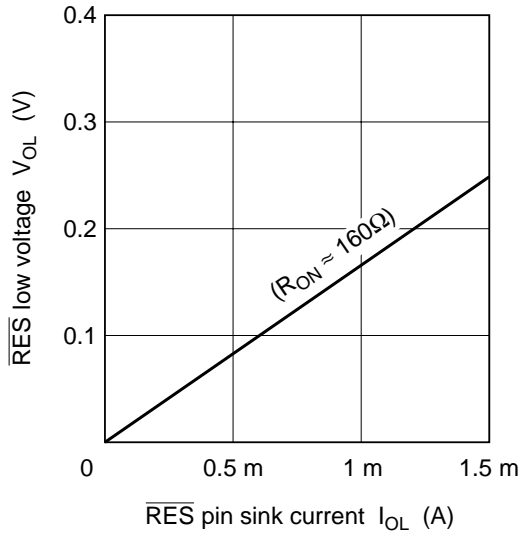

$\overline{\text{RES}}$ Low Voltage vs. Ambient Temperature

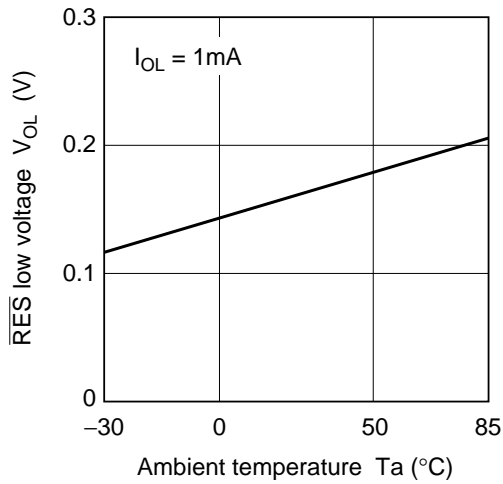

$\overline{\text{RES}}$ High Voltage vs. $\overline{\text{RES}}$ pin Source Current

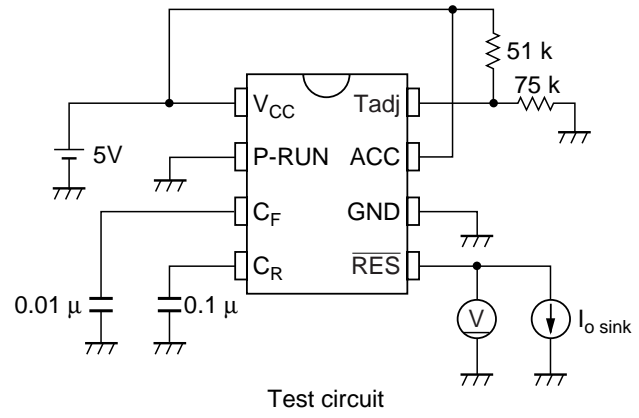
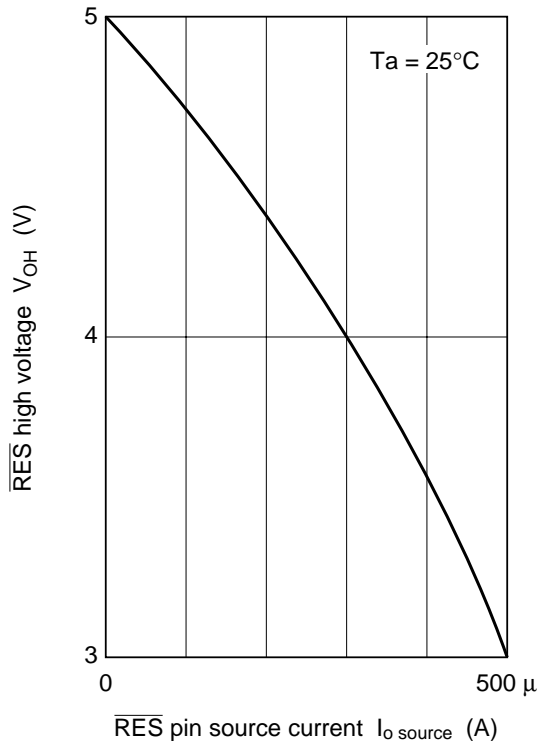

Power-on Reset Time vs. C_R Capacitance

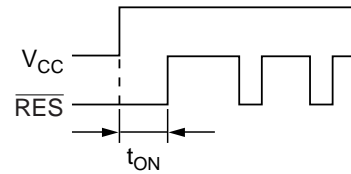
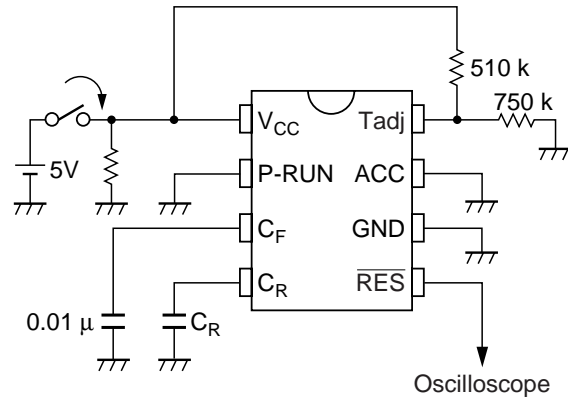
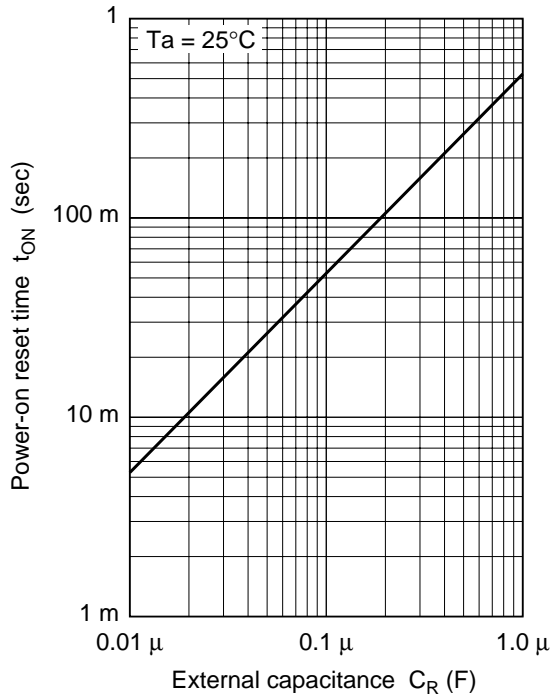

Test circuit

$\overline{\text{RES}}$ Output Timing vs. C_R Capacitance

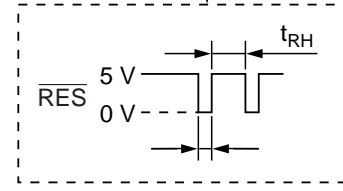
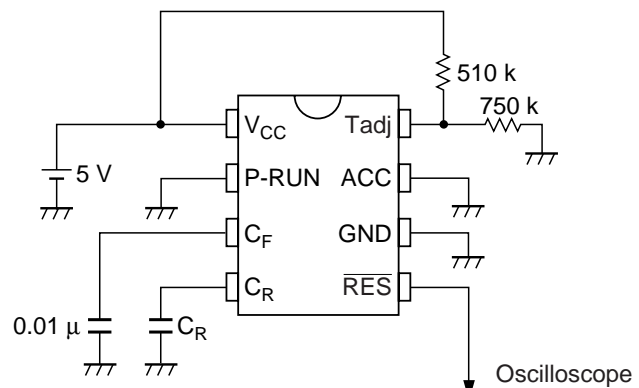
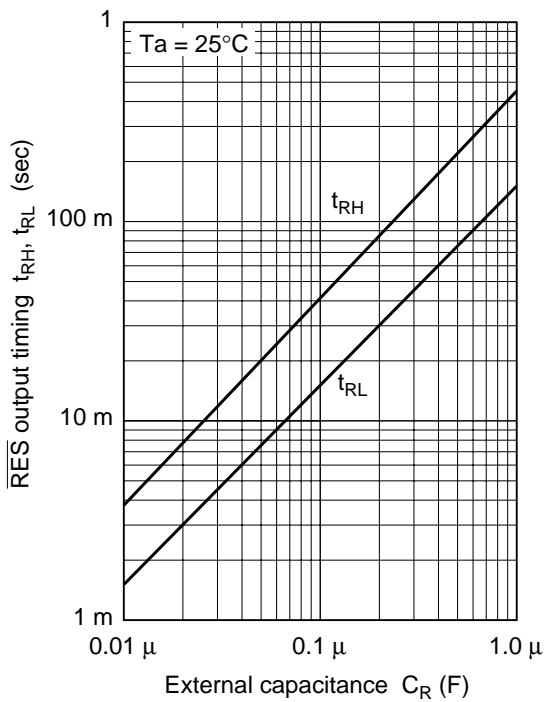

Test circuit

High Setup Time vs. C_R Capacitance

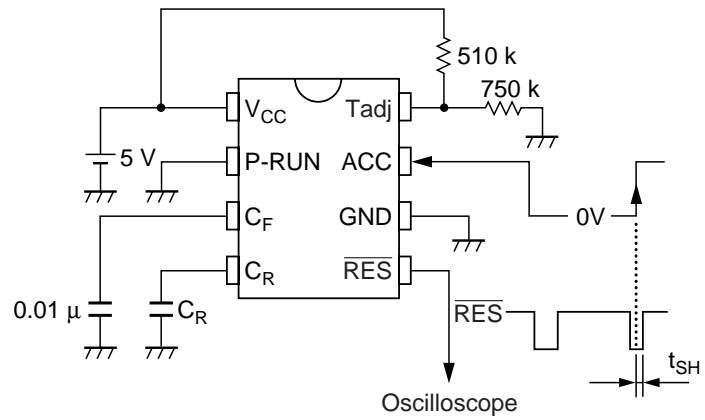
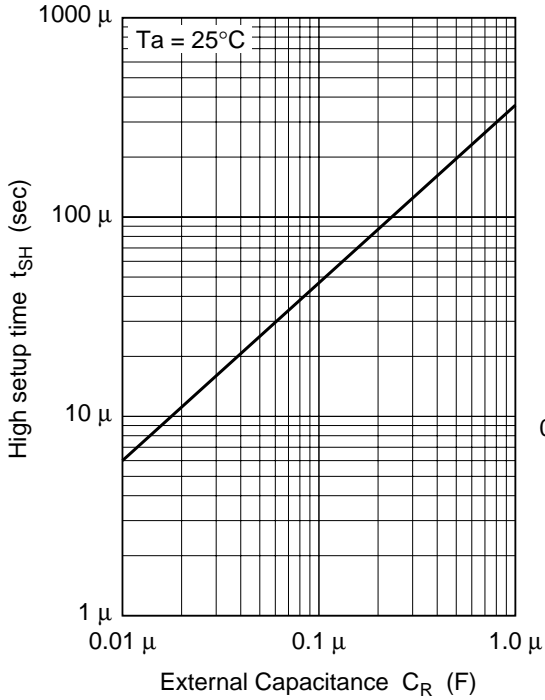

Test circuit

Low Setup Time vs. C_R Capacitance

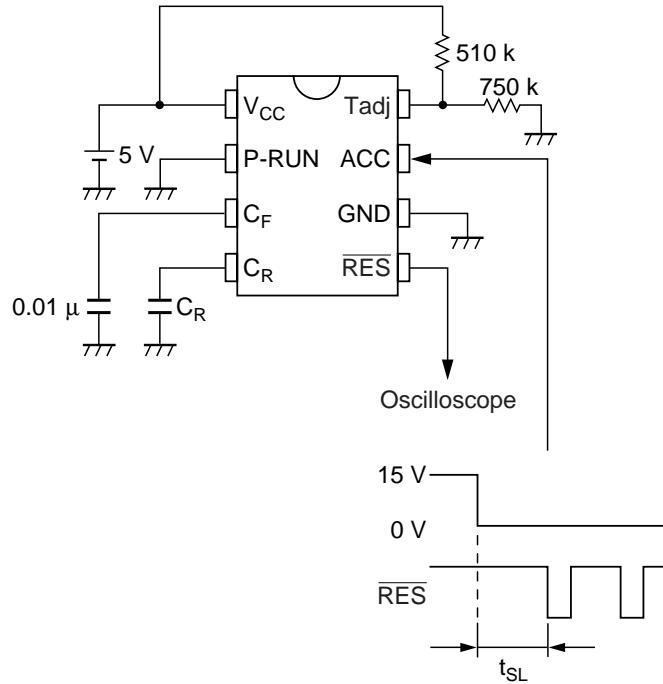
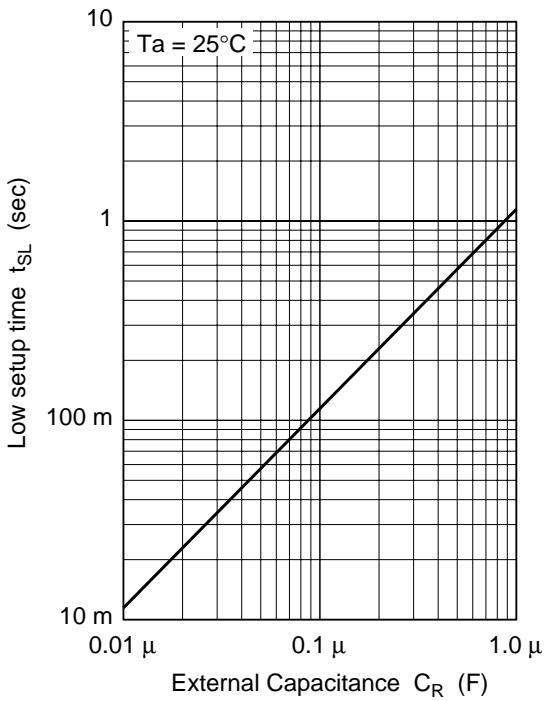

Test circuit

Reset High Time vs. K (Tadj Constant)

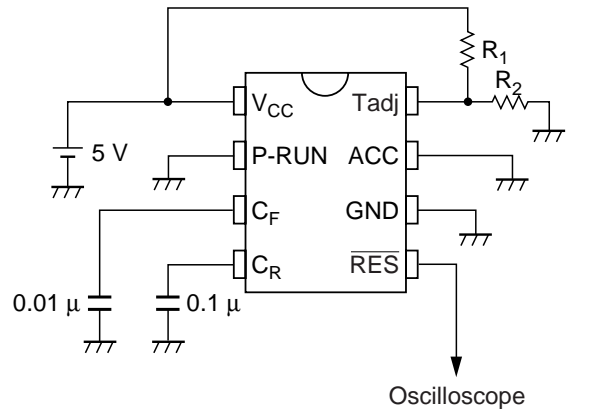
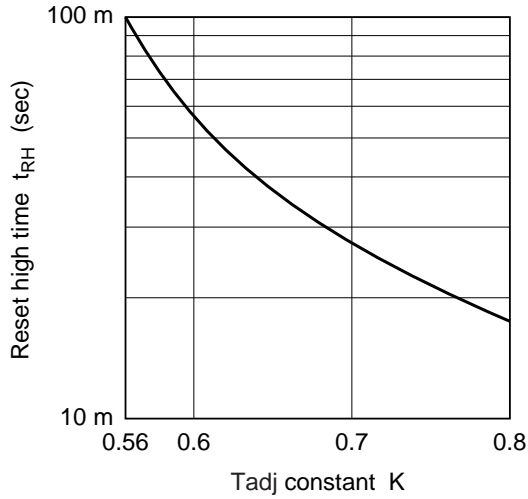

Test circuit

$$K = \frac{R_2}{R_1 + R_2}$$

Duty-cycle dependence of P-RUN normal frequency range

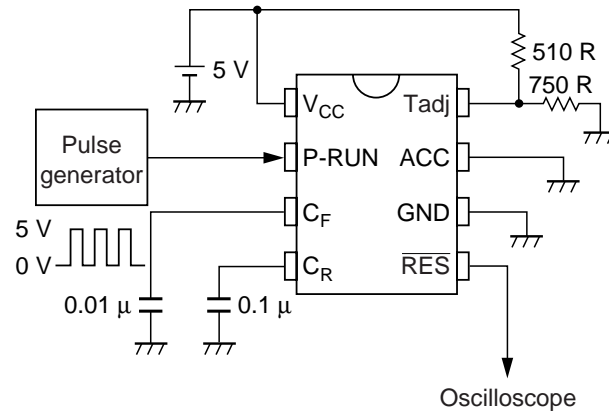
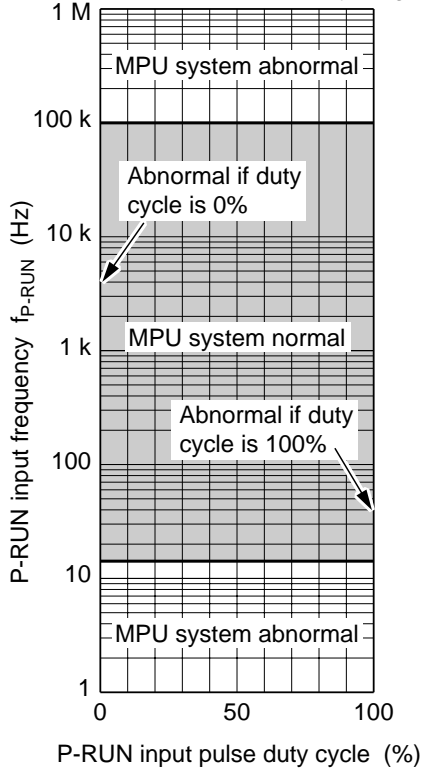

Test circuit

- Notes:
1. Normal detection is assumed when $\overline{\text{RES}}$ is not output.
 2. The figure at left is for a constant P-RUN frequency. See "8. Summary of cases where P-RUN frequency fluctuates" for cases where the frequency fluctuates.

P-RUN Input Frequency vs. K (Tadj constant)

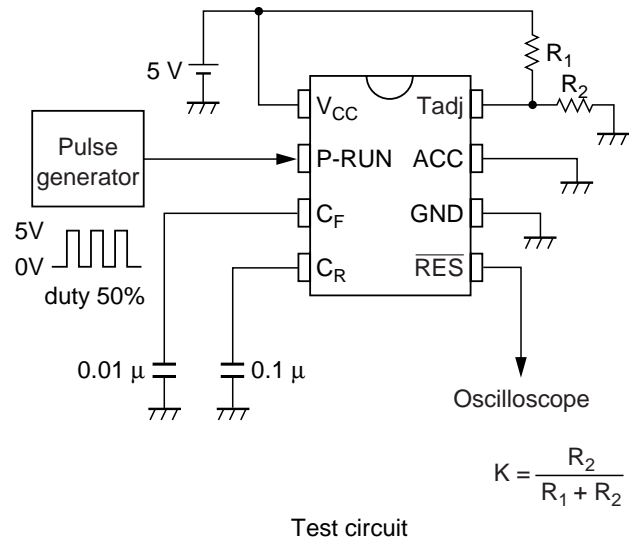
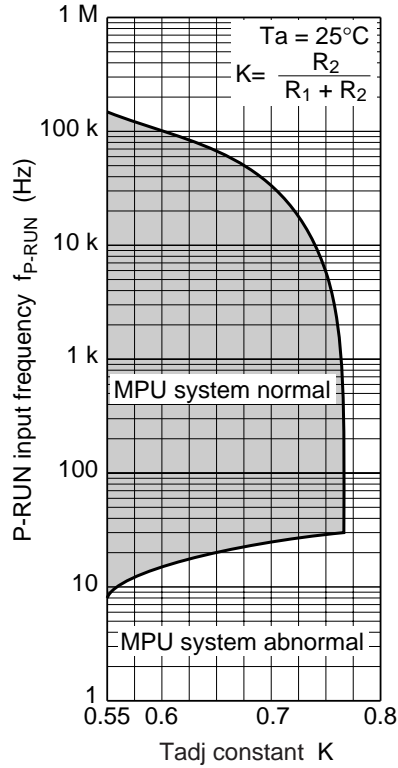

- Notes: 1. Normal detection is assumed when $\overline{\text{RES}}$ is not output.
- 2. The figure at left is for a constant P-RUN frequency.

P-RUN High Threshold Frequency vs. C_F Capacitance

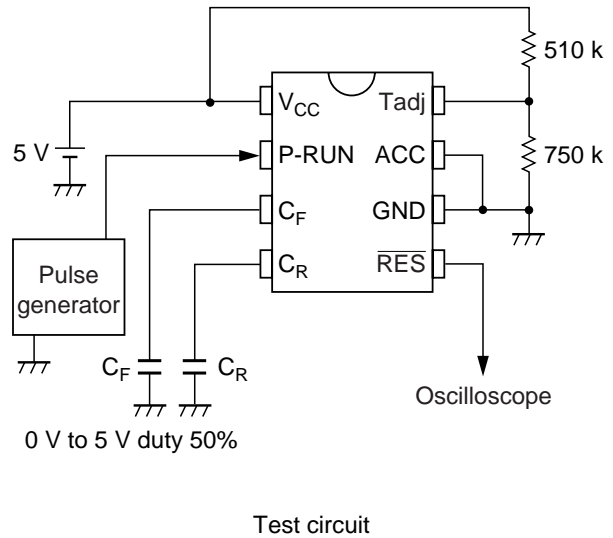
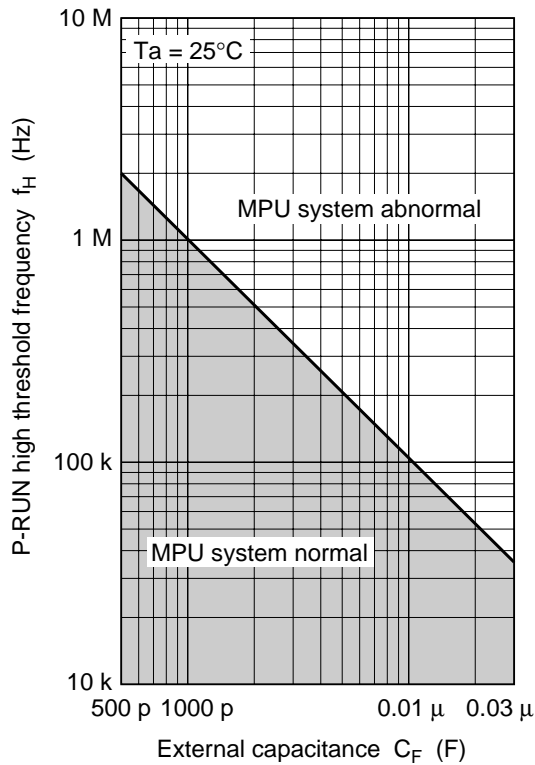

- Notes: 1. Normal detection is assumed when $\overline{\text{RES}}$ is not output.
- 2. The figure at left is for a constant P-RUN frequency.

P-RUN Low Threshold Frequency vs. C_F Capacitance

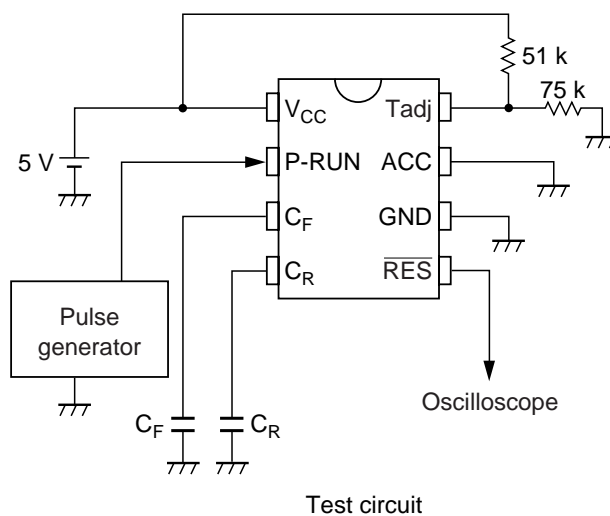
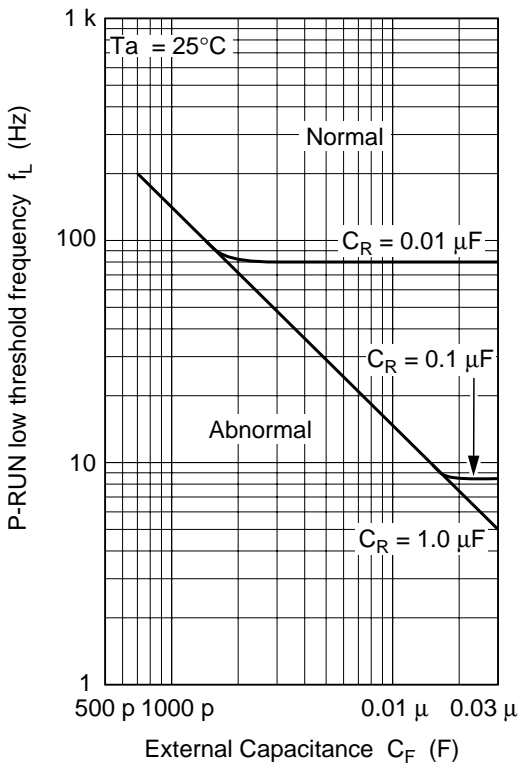

- Notes: 1. Normal detection is assumed when \overline{RES} is not output.
2. The figure at left is for a constant P-RUN frequency.

P-RUN Input Frequency vs. Ambient Temperature

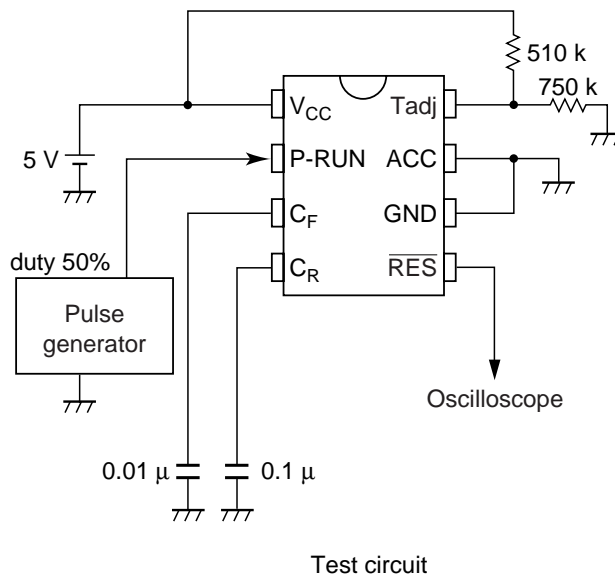
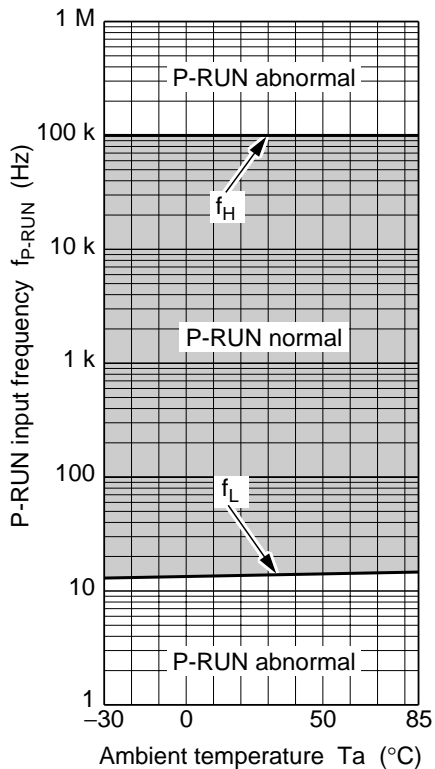

- Notes: 1. Normal detection is assumed when \overline{RES} is not output.
2. The figure at left is for a constant P-RUN frequency.

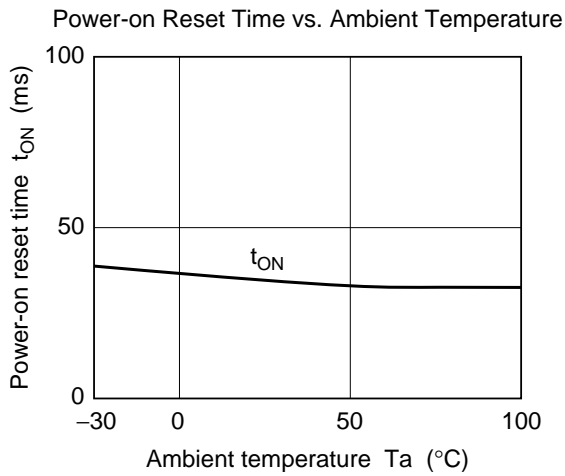

Power-on Reset Time vs. Ambient Temperature

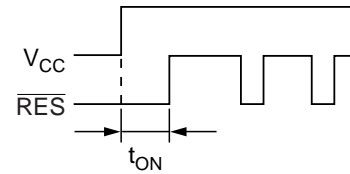
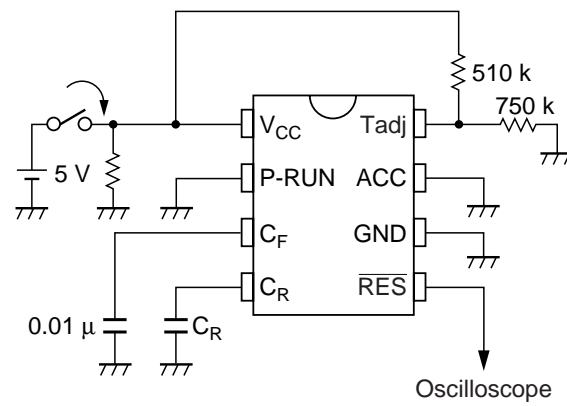

Test circuit

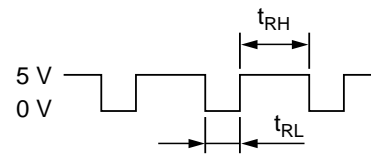
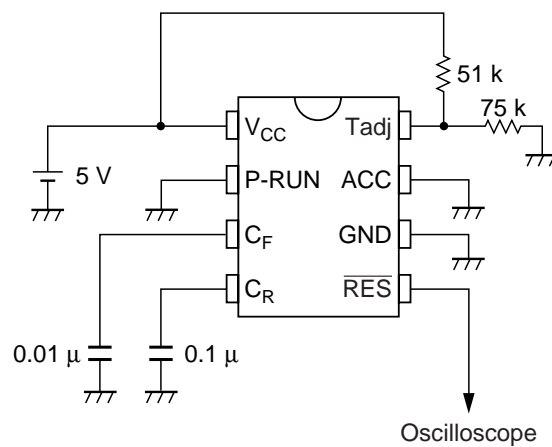
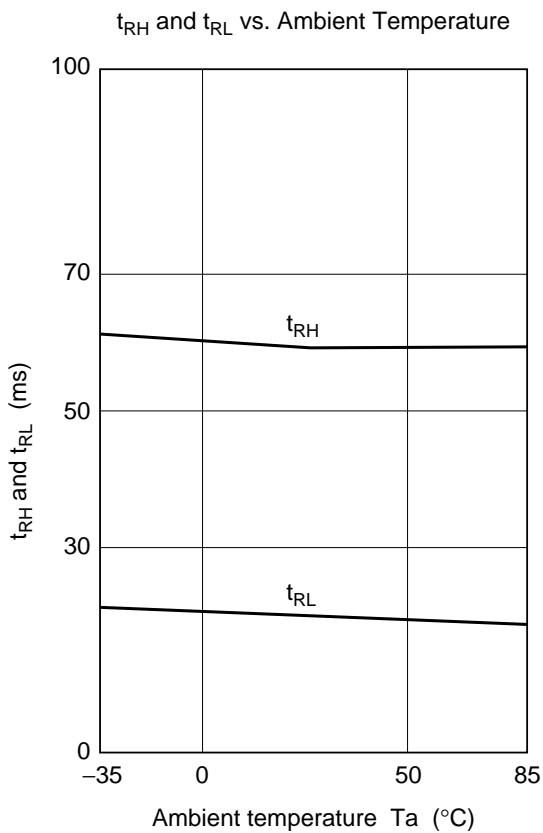

Test circuit

Package Dimensions

Unit: mm

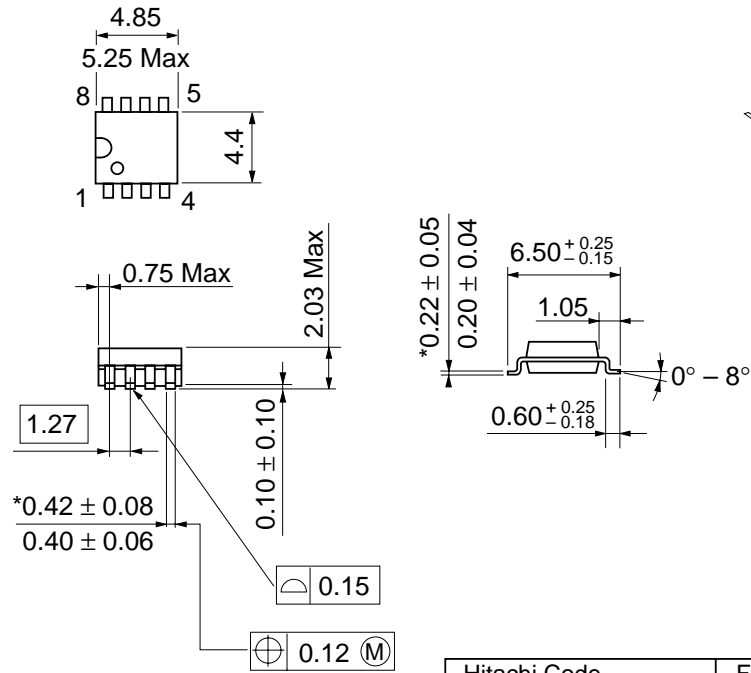

*Dimension including the plating thickness
Base material dimension

Hitachi Code	FP-8D
JEDEC	—
EIAJ	Conforms
Mass (reference value)	0.10 g

Cautions

1. Hitachi neither warrants nor grants licenses of any rights of Hitachi's or any third party's patent, copyright, trademark, or other intellectual property rights for information contained in this document. Hitachi bears no responsibility for problems that may arise with third party's rights, including intellectual property rights, in connection with use of the information contained in this document.
2. Products and product specifications may be subject to change without notice. Confirm that you have received the latest product standards or specifications before final design, purchase or use.
3. Hitachi makes every attempt to ensure that its products are of high quality and reliability. However, contact Hitachi's sales office before using the product in an application that demands especially high quality and reliability or where its failure or malfunction may directly threaten human life or cause risk of bodily injury, such as aerospace, aeronautics, nuclear power, combustion control, transportation, traffic, safety equipment or medical equipment for life support.
4. Design your application so that the product is used within the ranges guaranteed by Hitachi particularly for maximum rating, operating supply voltage range, heat radiation characteristics, installation conditions and other characteristics. Hitachi bears no responsibility for failure or damage when used beyond the guaranteed ranges. Even within the guaranteed ranges, consider normally foreseeable failure rates or failure modes in semiconductor devices and employ systemic measures such as fail-safes, so that the equipment incorporating Hitachi product does not cause bodily injury, fire or other consequential damage due to operation of the Hitachi product.
5. This product is not designed to be radiation resistant.
6. No one is permitted to reproduce or duplicate, in any form, the whole or part of this document without written approval from Hitachi.
7. Contact Hitachi's sales office for any questions regarding this document or Hitachi semiconductor products.

HITACHI

Hitachi, Ltd.

Semiconductor & Integrated Circuits.
 Nippon Bldg., 2-6-2, Ohte-machi, Chiyoda-ku, Tokyo 100-0004, Japan
 Tel: Tokyo (03) 3270-2111 Fax: (03) 3270-5109

URL North America : <http://semiconductor.hitachi.com/>
 Europe : <http://www.hitachi-eu.com/hel/ecg>
 Asia (Singapore) : <http://www.has.hitachi.com.sg/grp3/sicd/index.htm>
 Asia (Taiwan) : http://www.hitachi.com.tw/E/Product/SICD_Frame.htm
 Asia (HongKong) : <http://www.hitachi.com.hk/eng/bo/grp3/index.htm>
 Japan : <http://www.hitachi.co.jp/Sicd/indx.htm>

For further information write to:

Hitachi Semiconductor
 (America) Inc.
 179 East Tasman Drive,
 San Jose, CA 95134
 Tel: <1> (408) 433-1990
 Fax: <1>(408) 433-0223

Hitachi Europe GmbH
 Electronic components Group
 Dornacher Straße 3
 D-85622 Feldkirchen, Munich
 Germany
 Tel: <49> (89) 9 9180-0
 Fax: <49> (89) 9 29 30 00

Hitachi Europe Ltd.
 Electronic Components Group.
 Whitebrook Park
 Lower Cookham Road
 Maidenhead
 Berkshire SL6 8YA, United Kingdom
 Tel: <44> (1628) 585000
 Fax: <44> (1628) 778322

Hitachi Asia Pte. Ltd.
 16 Collyer Quay #20-00
 Hitachi Tower
 Singapore 049318
 Tel: 535-2100
 Fax: 535-1533

Hitachi Asia Ltd.
 Taipei Branch Office
 3F, Hung Kuo Building, No.167,
 Tun-Hwa North Road, Taipei (105)
 Tel: <886> (2) 2718-3666
 Fax: <886> (2) 2718-8180

Hitachi Asia (Hong Kong) Ltd.
 Group III (Electronic Components)
 7/F., North Tower, World Finance Centre,
 Harbour City, Canton Road, Tsim Sha Tsui,
 Kowloon, Hong Kong
 Tel: <852> (2) 735 9218
 Fax: <852> (2) 730 0281
 Telex: 40815 HITEC HX

Copyright ' Hitachi, Ltd., 1998. All rights reserved. Printed in Japan.

HITACHI