

## ZigBee™- Ready RF Transceiver Modules

### Product Description

The RC2200/2202/2204 RF Transceiver Modules are a series of compact surface-mounted modules specially designed for the ZigBee™ protocol stack for wireless star and mesh networks based on IEEE 802.15.4 compliant PHY and MAC layers providing 16 channels in the 2.45 GHz world-wide license-free ISM band. The complete shielded module is only 16.5 x 29.2 x 3.5 mm, optionally available with integrated antenna or RF connector. Up to 128 kB flash memory, 32 digital and analogue I/Os including an 8 channel 10 bit ADC, UART and SPI interfaces. The powerful internal resources make it possible to embed the complete application in this tiny module.

### Applications

- Home control and industrial automation
- Building automation
- OEM equipment
- Fleet and inventory management

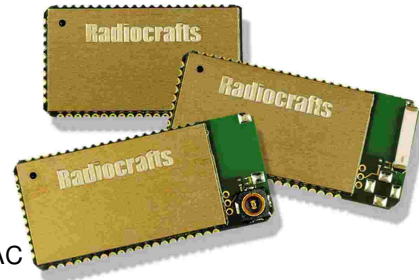

### Features

- ZigBee-ready / IEEE 802.15.4 compliant PHY and MAC
- Memory space for Full Function Device (FFD)
- 16.5 x 29.2 x 3.5 mm compact shielded module for SMD mounting
- Up to 128 kB Flash memory, 4 kB SRAM, 4 kB EEPROM
- 32 digital and analogue I/Os, 8 channel 10 bit ADC
- UART, SPI and JTAG interfaces
- On-board 32.768 kHz real time clock (RTC)
- High performance direct sequence spread spectrum (DSSS) RF transceiver
- 16 channels in the 2.45 GHz ISM band
- Integrated antenna or MMCX RF connector options
- 2.7 – 3.6 V supply voltage
- MCU and on-board RTC support ultra low power modes
- Conforms with EN 300 440 (Europe), FCC CFR 47 part 15 (US), ARIB STD-T66 (Japan)

### Quick Reference Data

Parameter	RC2200	RC2202	RC2204	Unit
Frequency band	2.400-2.4835			GHz
Number of channels	16			
Data rate	250			kbit/s
Max output power	0			dBm
2 <sup>nd</sup> harmonic	-37			dBm
3 <sup>rd</sup> harmonic	-51			dBm
Sensitivity (PER 1%)	-94			dBm
Adjacent Channel Rejection	39			dB
Alternate Channel Rejection	55			dB
Supply voltage	2.7 – 3.6			Volt
Current consumption, RX	30	26	30	mA
Current consumption, TX	27	23	27	mA
Current consumption, PD	1.3			uA
Flash memory	128	32	64	kB
RAM	4	2	4	kB
EEPROM	4	1	2	kB
Operating Temperature	-30 to +85			°C

**PRELIMINARY INFORMATION.** Specifications and information herein are subject to change without notice.

### Quick Product Introduction

The RC220x series of modules are specially designed to meet the IEEE 802.15.4 standard used by ZigBee and a variety of proprietary network protocols. Using the module together with the Chipcon / Figure 8 Wireless Z-stack or any other ZigBee network implementation makes it a powerful platform to build any ZigBee profile and application. The module contains qualified RF hardware and enough processor power to run the complete ZigBee mesh network protocol for a full function device including the application.

Using a pre-qualified module is the fastest way to make a ZigBee product and shortest time to market. Because it contains all the RF HW and MCU resources you need in a 100% RF tested and pre-qualified module shorten the qualification and approval process. No RF design or expertise is required to add powerful wireless networking to the product. As an option you can even get the module with integrated antenna or coaxial MMCX connector. In the simplest case like a home light remote control you only need an external battery and a pushbutton.

You may find more general information on how to build a ZigBee application Radiocrafts application note AN003.

### Typical Application Circuit

Below is shown a Serial Port application circuit. The JTAG and ISP are also shown.

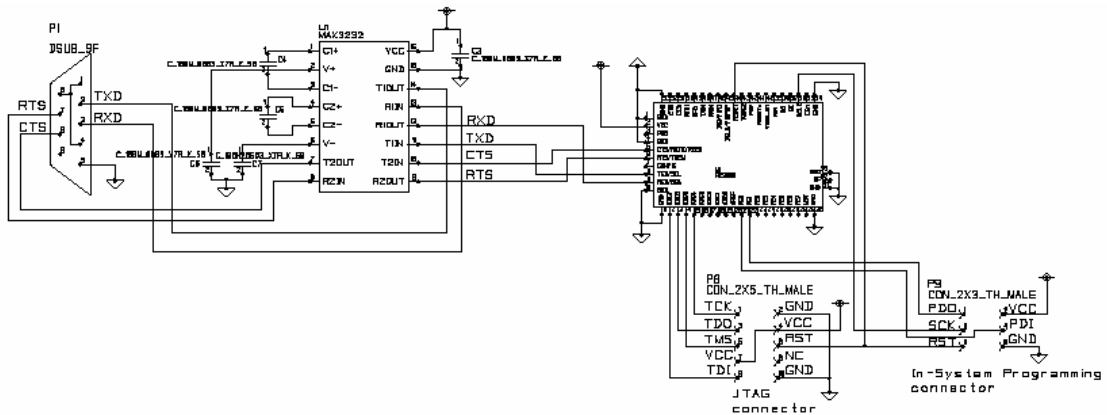

Full resolution schematic is found in [RC2200 Application Circuit SPP 1 0.pdf](#)

### Frequently Asked Questions

#### *What is IEEE 802.15.4?*

It is a standard for low data rate wireless Personal Area Networks (PAN) focusing on low power, low cost and robustness. It defines a Physical layer (PHY) and a Medium Access Control layer (MAC) and is the basis for the open ZigBee protocol or proprietary protocols.

#### *What is ZigBee?*

ZigBee is an open global standard aimed for wireless network communication between devices in home control, industrial and building automation applications. It provides star, cluster tree and mesh topologies (see illustration). The multi-hop and ad-hoc routing properties is ideal for non-static networks covering a house or building.

#### *How do I implement my application?*

Your application can be implemented on top of the ZigBee stack sharing the resources in the embedded microcontroller. An extensive number of digital and analogue I/Os can be used to directly interface sensors, switches and actuators. Timing applications can use the on-board 32 kHz real-time clock. Ultra low power modes are ideal for battery operation.

#### *What about the ZigBee stack?*

In principle any third-party ZigBee stack implementation can be used with the module. But in particular the module is intended for use with the Chipcon / Figure 8 Wireless Z-stack and MAC. The Z-stack royalty fee is included in the module cost. The Z-stack license and software development tools are available from Chipcon.

#### *What development tools do I need?*

The following development tools for the embedded MCU (Atmel mega128) are recommended and available free of charge:

- WinAVR / AVR GCC / Programmer's Notepad
- Atmel AVR Studio

The Atmel JTAG ICE mkII can be used to download the program into the embedded controller.

### Pin Assignment

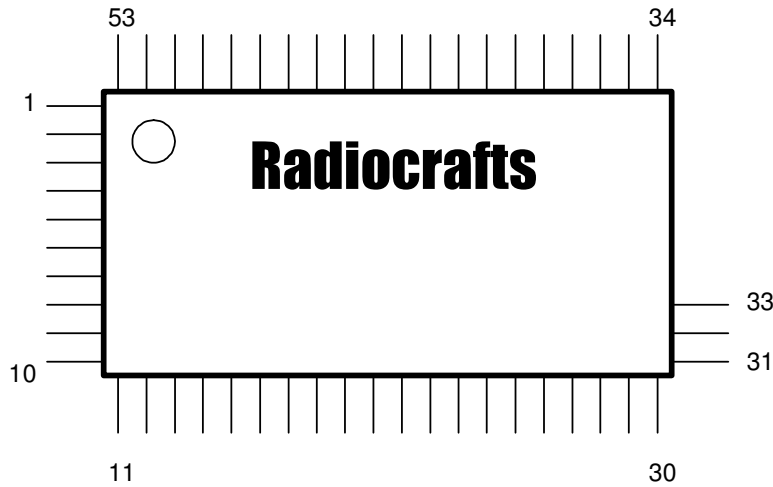

### Pin Description

Pin no	Pin name	Description and internal MCU connection
1	GND	System ground
2	VCC	Supply voltage input
3	PG0	Digital I/O, PG0
4	GND	System ground
5	CTS1	Digital I/O, PD7 / CTS1
6	RTS1	Digital I/O, PD5 / RTS1
7	PG2	Digital I/O, PG2
8	TXD1	Digital I/O, PD3 / TXD1 / INT3
9	RXD1	Digital I/O, PD2 / RXD1 / INT2
10	GND	System ground
11	GND	System ground
12	ADC7	Digital or analogue I/O, PF7, JTAG TDI
13	ADC6	Digital or analogue I/O, PF6, JTAG TDO
14	ADC5	Digital or analogue I/O, PF5, JTAG TMS
15	ADC4	Digital or analogue I/O, PF4, JTAG TCK
16	ADC3	Digital or analogue I/O, PF3
17	ADC2	Digital or analogue I/O, PF2
18	ADC1	Digital or analogue I/O, PF1
19	ADC0	Digital or analogue I/O, PF0
20	AREF	Analogue reference voltage pin for the internal A/D Converter. Internally decoupled with 22nF.
21	PE0	Digital I/O, PE0, ISP PDI for RC2200 and RC2204
22	PE1	Digital I/O, PE1, ISP PDO for RC2200 and RC2204
23	PE2	Digital I/O, PE2
24	PE3	Digital I/O, PE3
25	PE4	Digital I/O, PE4 / INT4
26	PE5	Digital I/O, PE5 / INT5
27	PE6	Digital I/O, PE6 / INT6
28	PE7	Digital I/O, PE7 / INT7
29	1.8V	Internally regulated voltage. Normally not connect. May be used for AREF
30	GND	System ground

31	GND	System ground
32	RF	RF I/O connection to antenna, 50 Ohm. Do not connect for integrated antenna or connector variant.
33	GND	System ground
34	GND	System ground
35	Reserved	Do not connect, PB0
36	SCLK	SPI interface must be shared with MAC, PB1, ISP SCK
37	SI	SPI interface must be shared with MAC, PB2, PDI for RC2202
38	SO	SPI interface must be shared with MAC, PB3, PDO for RC2202
39	PB4	Digital I/O, PB4
40	Reserved	Do not connect, PB5
41	Reserved	Do not connect, PB6
42	PB7	Digital I/O, PB7
43	TOSC2	Internal 32.768 kHz oscillator
44	RESET	Internal MCU reset. Active low with internal pull-up.
45	Reserved	Do not connect, PD0 / INT0
46	Reserved	Do not connect, PD1 / INT1
47	RXD1	Same as pin 9
48	TXD1	Same as pin 8
49	Reserved	Do not connect, PD4
50	RTS1	Same as pin 6
51	Reserved	Do not connect, PD6
52	CTS1	Same as pin 5
53	GND	System ground

Note 1: UART interface: Pin 8 TXD1, pin 9 RXD1, pin 5 CTS1, pin 6 RTS1

Note 2: SPI interface: Pin 36 SCLK, pin 37 SI, pin 38 SO (chip select at any digital I/O) must be shared with internal MAC software

Note 3: ISP (In-System Programming) interface: Pin 36 SCK, pin 21 PDI, pin 22 PDO, pin 44 RESET for RC2200 and RC2204. Pin 36 SCK, pin 37 PDI, pin 38 PDO, pin 44 RESET for RC2202. See page 8 for more information.

Note 4: JTAG interface: Pin 12 TDI, pin 13 TDO, pin 14 TMS, pin 15 TCK, pin 44 RESET. See page 8 for more information.

### Block Diagram

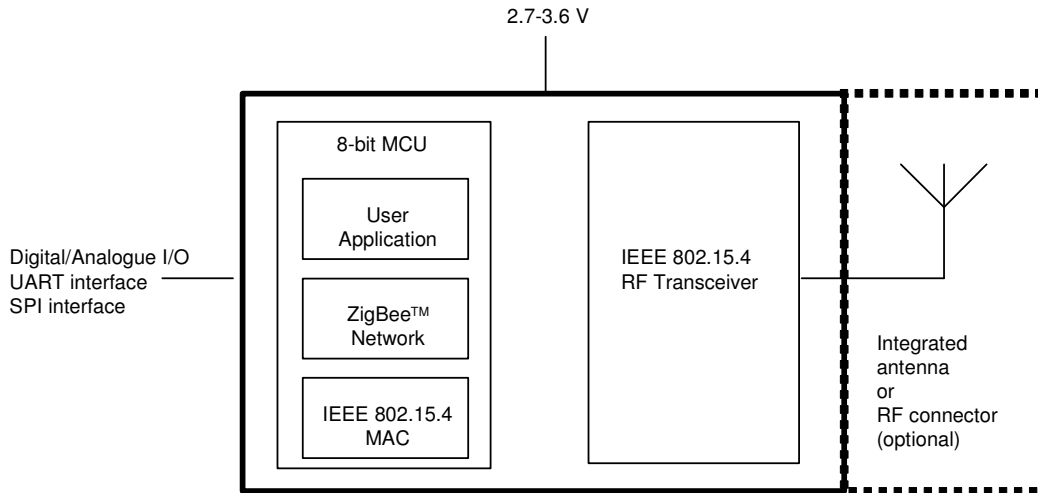

### Embedded resources

MCU: Atmel mega128L, mega64L or mega325

PHY/MAC: Chipcon CC2420

Chipcon / Figure 8 Wireless Z-stack royalty fee included

### Circuit Description

The module contains a micro controller unit (MCU) and an IEEE 802.14.4 compliant RF transceiver with internal voltage regulator. The module is intended for running the ZigBee network protocol.

The application software together with the ZigBee protocol software stack can be programmed in Flash memory through JTAG or ISP interfaces. The JTAG interface can also be used for debugging. The MCU runs at 8 MHz and contains on-chip RAM and non-volatile EEPROM memory.

The MCU controls the RF transceiver through an SPI interface and hardware handshake signals. The firmware controlling the RF transceiver is part of the MAC software. The antenna output is internally matched to 50 Ohms, optionally using an integrated antenna.

The supply voltage is connected to the VCC pin. The module contains an internal low noise voltage regulator for the RF transceiver, and can therefore operate over a wide supply voltage range. The regulated voltage is available at the 1.8V pin (pin 29), but should not be used to supply external circuits except for connection to AREF, being a reference for the internal A/D converter.

The module provides 2 UART interfaces, SPI interface, JTAG interface. Totally 32 I/O pins are available to the user. 8 pins can be used for the internal 10 bit A/D converter. 6 of the digital I/Os have interrupt features.

The MCU provides several low power modes with can be utilized to reduce the current consumption in battery operated applications. An internal 32 kHz crystal oscillator can be used for real-time clock and timer applications.

For further details on the RF transceiver (Chipcon CC2420) and MCU (Atmel mega128L, mega64L or mega325), please consult the respective data sheets.

### IEEE 802.15.4

The IEEE 802.15.4 standard, approved in May 2003, provides a worldwide standard for Personal Area Networks or short distance wireless networks for low data rate solutions with long battery life and very low complexity. It defines a Physical layer (PHY) and a Medium Access Control layer (MAC) and is the basis for the open ZigBee protocol or proprietary protocols. The typical applications are home and building automation, industrial control and monitoring systems, wireless sensor networks, remote controls and consumer electronics.

The module complies with the IEEE 802.15.4 standard operating in the 2.45 GHz band. It uses direct sequence spread spectrum (DSSS) with 2 Mc/s chip rate giving a raw data rate of 250 kbit/s. 16 channels are available in the 2.45 GHz band, channel 11 – 26 (channels 0-10 are reserved for use in the 868 and 915 MHz bands).

For more information on the standard, please consult [www.ieee802.org/15/pub/TG4.html](http://www.ieee802.org/15/pub/TG4.html)

#### Reference:

IEEE std 802.15.4 -2003: Wireless Medium Access Control (MAC) and Physical layer (PHY) specifications for Low Rate Wireless Personal Area Networks (LR-WPANs)  
<http://standards.ieee.org/getieee802/download/802.15.4-2003.pdf>

### The ZigBee Protocol

The ZigBee Alliance is an association of companies working together to enable reliable, cost-effective, low-power, wirelessly networked, monitoring and control products based on an open global standard. The ZigBee Alliance is a rapidly growing, non-profit industry consortium of leading semiconductor manufacturers, technology providers, OEMs and end-users worldwide. Membership is open to all. The ZigBee Alliance, in collaboration with the IEEE, is defining the network, security, and application layers above the IEEE 802.15.4 PHY and MAC layers. This cooperation has resulted in an easy-to-use, standards-based wireless network platform optimised for wireless monitoring and control applications. For more information about the ZigBee Alliance and the ZigBee standard, please consult [www.zigbee.org](http://www.zigbee.org)

The module is intended for using the ZigBee protocol. However, other proprietary network protocols can also be implemented using the module.

The ZigBee stack implementation from Chipcon/Figure 8 Wireless is recommended as it provides seamless integration with the module. However, third party stack implementations can also be used provided they support the Chipcon MAC firmware.

### JTAG Interface

The module offers a JTAG interface for Flash and EEPROM programming, as well as for debugging.

Programming through the JTAG interface requires control of the four JTAG specific pins: TCK, TMS, TDI, and TDO. Control of the reset and clock pins is not normally required. To be able to use the JTAG interface, the JTAGEN Fuse must be programmed. The device is default shipped with the fuse programmed. For further information, please refer to the respective MCU data sheet.

The table below show the JTAG pin mapping.

Signal	RC2200	RC2202	RC2204
TDI	12	12	12
TDO	13	13	13
TMS	14	14	14
TCK	15	15	15
RESET	44	44	44

Supply and ground must also be connected during programming.

### ISP Interface

The module offers an In-System Programming (ISP) interface for Flash and EEPROM memory programming. The fastest way to do firmware downloading in manufacturing is through the ISP interface rather than the JTAG interface.

The memory arrays can be programmed using the serial interface bus while RESET is pulled to GND. The serial interface consists of pins SCK, PDI/MOSI (input) and PDO/MISO (output). The RC2200 and RC2204 use the PDI and PDO pins (shared with UART0), while RC2202 use MOSI and MISO (shared with SPI interface), see table below.

After RESET is set low, the Programming Enable instruction needs to be executed first before program/erase operations can be executed. More information is available in the respective MCU data sheets.

The table below show the pin mapping for ISP programming.

Signal	RC2200	RC2202	RC2204
PDI	21	37	21
PDO	22	38	22
SCL	36	36	36
RESET	44	44	44

Supply and ground must also be connected during programming.



### Power Management

The ZigBee protocol allows End Devices to be powered down, while Routers must be powered all the time in order to handle packet routing. Battery operated devices should be End Devices in order to reduce the power consumption to a minimum.

The module can be set in several sleep modes using the features of the MCU and turning off the RF transceiver. Sleep modes enable the application to shut down unused modules in the MCU, thereby saving power. The MCU provides various sleep modes allowing the user to tailor the power consumption to the application's requirements. To enter any of the six sleep modes available in the ATmega128L/64L/325, the SE bit in MCUCR must be written to logic one and a SLEEP instruction must be executed. The SM2, SM1, and SM0 bits in the MCUCR Register select which sleep mode (Idle, ADC Noise Reduction, Power-down, Power-save, Standby, or Extended Standby) will be activated by the SLEEP instruction. For further information on using the various sleep modes, please refer to the respective MCU data sheets.

In applications like switch remote controls, the switch buttons should be connected to one of the interrupt pins. PIR sensors (for occupancy detection) and light sensors should also be using pin interrupts to awake the device from power down mode (PD). During PD the pin interrupts are still active.

Temperature sensors, humidity sensors and similar could be polled at regular intervals using the 32 kHz low frequency oscillator timer to awake the device. In this case using the Idle mode with 32 kHz oscillator is recommended. This mode is not available for RC2202.

In order to ensure that the internal Power On Reset (POR) operates correctly, the maximum rise-time specification for VCC must be met (see Electrical Specifications). If longer rise-time is expected it is recommended to use an external POR circuit attached to the RESET pin (see Application Note AN001). Slow VCC rise-time or short power interruptions may cause improper operation that is not handled by the internal POR. In this case the RESET should be activated in order to ensure proper start-up.

### RF Frequency, Output Power Levels and Data Rates

The following table shows the RF channels as defined by the IEEE 802.15.4 standard.

RF channel	Frequency
11	2405 MHz
12	2410 MHz
13	2415 MHz
14	2420 MHz
15	2425 MHz
16	2430 MHz
17	2435 MHz
18	2440 MHz
19	2445 MHz
20	2450 MHz
21	2455 MHz
22	2460 MHz
23	2465 MHz
24	2470 MHz
25	2475 MHz
26	2480 MHz

For proprietary solutions (non-IEEE 802.15.4), the RF transceiver can be programmed in steps of 1 MHz.

The output power level can be configured from the firmware in the range -25 to 0 dBm.

The RF transceiver uses direct sequence spread spectrum (DSSS) with 2 Mchip/s chip rate, giving a raw data rate of 250 kbit/s. The modulation format is Offset – Quadrature Phase Shift Keying (O-QPSK). The DSSS makes the communication link robust in noisy environments when sharing the same frequency band with other applications.

The use of RF frequencies and maximum allowed RF power is limited by national regulations. The RC2200 series is complying with the applicable regulations for the world wide 2.45 GHz ISM band.

Specifically it complies with the European Union R&TTE directive meeting EN 300 328 and EN300 440 class 2. It also meets the FCC CFR47 Part15 regulations for use in the US and the ARIB T-66 for use in Japan.

### Antenna and Range Considerations

As an option the module is delivered with an integrated antenna (RC220xAT). This is highly recommended for most applications, as this gives a very compact solution containing all the critical RF parts within the module.

Range testing using the integrated antenna shows these typical distances:

- 110 meter outdoor line-of-sight (LOS)
- 10-30 meters indoors depending on building material and construction
- 10-15 meters when passing through floors
- 25-30 meters in the same floor

The variation between different orientations of the antenna measured outdoors line-of-sight is typically within +/- 20%.

The integrated antenna is a compact ceramic antenna working as a quarter-wave resonant antenna. Due to the dielectric ceramic material the antenna is shorter than a normal quarter wave antenna (in air), still providing high radiation efficiency (typical 1 dBi). The antenna is matched for use in the 2.45 GHz band. The radiating part of the antenna is the white ceramic component located outside the shield can. The radiation pattern from the antenna is similar to the donut-shaped radiation from a quarter wave antenna. That is, the maximum radiation is in the plane normal to the length axis of the antenna. For best possible omni-directional radiation the module should be oriented so that the antenna is vertical. To achieve the very best range the transmitting and receiving antenna should be oriented the same way, ensuring the same polarity at both devices. However, indoors reflections of the radio waves in metallic structures tend to spread the polarisation, so even if same orientation is not possible, communication will still take place, but the range is somewhat shorter, typically by 20%.

The antenna should be kept away (> 10mm) from metallic or other conductive and dielectric materials, and should never be used inside a metallic enclosure.

Compared to lower frequencies, operation at 2.45 GHz is more limited to LOS. Reflections from walls and other objects may give multi-path fading resulting in dead-zones. The ZigBee mesh network topology is used to overcome this fading as it allows for alternative routing paths. The mesh network is therefore highly recommended for increased reliability and extended coverage throughout buildings.

In applications where the module must be placed in a metallic enclosure, an external antenna must be used. The MMCX connector option (RC220xMM) can then be used to launch a coaxial cable connecting to the external antenna. It is not recommended to connect a whip antenna directly to the MMCX connector as it does not support the mechanical strength required for necessary robustness with such an antenna.

If the option without antenna or MCCX is chosen (RC220x), the RF output must be connected to an antenna through the RF pin. The RF input/output is matched to 50 Ohm. If the antenna or antenna connector is placed away from the module at the motherboard, the track between the RF pin and the connector should be a 50 Ohm transmission line.

On a two layer board made of FR4 the width of a microstrip transmission line should be 1.8 times the thickness of the board, assuming a dielectric constant of 4.8. The line should be run at the top of the board, and the bottom side should be a ground plane.

Example: For a 1.6 mm thick FR4 board, the width of the trace on the top side should be  $1.8 \times 1.6 \text{ mm} = 2.88 \text{ mm}$ .

The simplest antenna to use is the quarter wave whip antenna. A quarter wave whip antenna above a ground plane yields 37 Ohm impedance and a matching circuit for 50 Ohm are usually not required.

A PCB antenna can be made as a copper track where the ground plane is removed on the back side. The rest of the PCB board should have a ground plane as large as possible, preferably as large as the antenna itself, to make it act as a counterweight to the antenna. If the track is shorter than a quarter of a wavelength, the antenna should be matched to 50 ohms.

The length of a quarter wave antenna is 2.9 cm at 2450 MHz.

### PCB Layout Recommendations

The recommended layout pads for the module are shown in the figure below (top view, pin 1 is in upper left corner, see pin assignment at page 4). All dimensions are in thousands of an inch (mil). The circle in upper left corner is an orientation mark only, and should not be a part of the copper pattern.

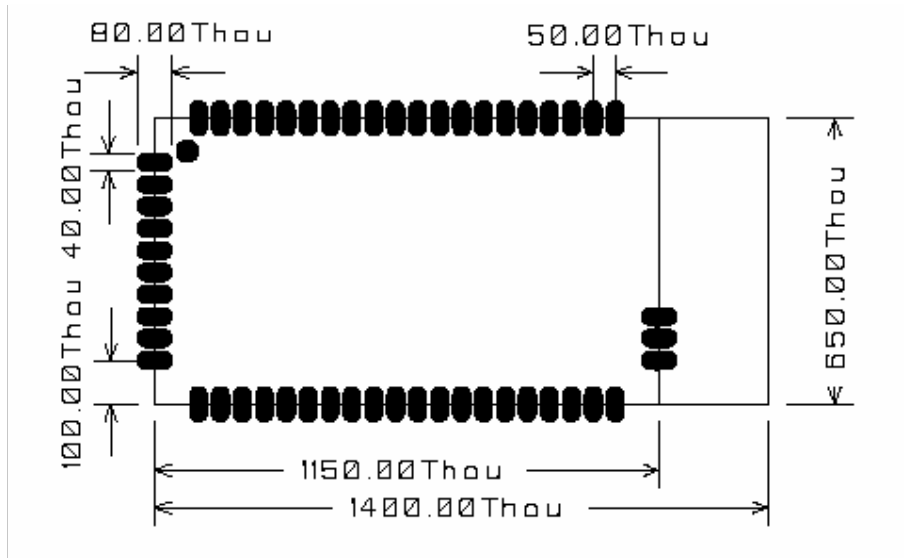

The area underneath the module should be covered with solder resist in order to prevent short circuiting the test pads on the back side of the module. A solid ground plane is preferred. Unconnected pins should be soldered to the pads, and the pads should be left floating. For the module version with integrated antenna or MMCX connector, the RF pad (pin 31) can be soldered, but the pad should not be connected further. The two ground pads (pin 30 and 32 on the right side) should be grounded for all variants.

### Mechanical Drawing

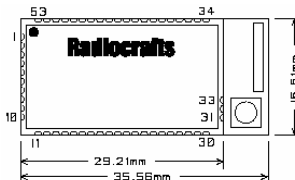

### Mechanical Dimensions

The module size is 0.65" x 1.15" x 0.14" (16.5 x 29.2 x 3.5 mm) without the antenna / MMCX connector. The length is 1.4" (35.6 mm) with the optional antenna / MMCX RF connector.

### Carrier Tape and Reel Specification

Carrier tape and reel is in accordance with EIA Specification 481.

Tape width	Component pitch	Hole pitch	Reel diameter	Units per reel
56 mm	20 mm	4 mm	13"	Max 800

### Absolute Maximum Ratings

Parameter	Min	Max	Unit
Supply voltage, VCC	-0.3	3.6	V
Voltage on any pin	-0.3	VCC+0.5	V
Input RF level		10	dBm
Storage temperature	-50	150	°C
Operating temperature	-30	85	°C

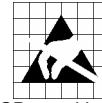

**Caution ! ESD sensitive device.**  
Precaution should be used when handling the device in order to prevent permanent damage.

Under no circumstances the absolute maximum ratings given above should be violated. Stress exceeding one or more of the limiting values may cause permanent damage to the device.

### Electrical Specifications

T=25°C, VCC = 3.0V if nothing else stated.

Parameter	Min	Typ.	Max	Unit	Condition / Note
Operating frequency	2400		2483	MHz	Programmable in 1 MHz steps, 5 MHz steps for IEEE 802.15.4 compliance
Number of channels		16			For IEEE 802.15.4 compliance
Channel spacing		5		MHz	For IEEE 802.15.4 compliance
Input/output impedance		50		Ohm	
Data rate		250		kbit/s	
DSSS chip rate		2		Mc/s	
Frequency stability			+/-40	ppm	
Transmit power	-25		0	dBm	Programmable from firmware
Harmonics 2 <sup>nd</sup> harmonic 3 <sup>rd</sup> harmonic		-37 -51			
Spurious emission, TX 30 – 1000 MHz 1-12.75 GHz 1.8-1.9 GHz 5.15-5.3 GHz			-36 -30 -47 -47	dBm	Complies with EN 300 328, EN 300 440, FCC CRF47 Part 15 and ARIB STD-T66
Sensitivity		-94		dBm	PER = 1%
Adjacent channel rejection +/- 5 MHz		46/39		dB	At -82 dBm, PER = 1%. 0 dB for IEEE 802.15.4 compliance
Alternate channel selectivity +/- 10 MHz		58/55		dB	At -82 dBm, PER = 1%. 30 dB for IEEE 802.15.4 compliance
Blocking / Interferer rejection / desensitization +/- 5 MHz +/- 10 MHz +/- 20 MHz +/- 50 MHz	-50 -45 -40 -30	-24 -24 -24 -23		dBm	Wanted signal 3 dB above sensitivity level, CW interferer, PER = 1%. Minimum numbers corresponds to class 2 receiver requirements in EN 300 440.
Saturation	0	10		dBm	
Spurious emission, RX 30 -1000 MHz 1-12.75 GHz			-57 -47	dBm	Complies with EN 300 328, EN 300 440, FCC CRF47 Part 15 and ARIB STD-T66

Supply voltage	2.7		3.6	V	
Supply voltage rise time			150	us	If appropriate rise time can not be guaranteed, the RESET pin should be activated after supply voltage is stable.
Current consumption, RX RC2200, RC2204 RC2202		30 26		mA	MCU in Idle mode using the 8 MHz oscillator.
Current consumption, TX RC2200, RC2204 RC2202		27 23		mA	At 0 dBm output power. MCU in Idle mode using the 8 MHz oscillator.
Current consumption, IDLE RC2200, RC2204 RC2202		23 NA		μA	MCU in Idle mode using the 32 kHz oscillator. Not available for RC2202.
Current consumption, PD		1.3		μA	MCU in Power-down mode, watchdog disabled
MCU Flash memory RC2200 RC2202 RC2204		128 32 64		kB	
MCU RAM memory RC2200 RC2202 RC2204		4 2 4		kB	
MCU EEPROM memory RC2200 RC2202 RC2204		4 1 2		kB	
MCU clock frequency		8		MHz	
MCU low frequency crystal		32.768		kHz	
Digital I/O Input logic level, low Input logic level, high Output logic level, low (10 mA) Output logic level, high(-10 mA)	-0.5 0.6 VCC 0 2.4		0.2 VCC VCC + 0.5 0.5 3.0	V	Except RC2202: max 0.3 VCC  Except RC2202: min 2.3 V
RESET pin Input logic level, low Input logic level, high	-0.5 0.85 VCC		0.2 VCC VCC + 0.5	V	
Internal RESET pull-up resistor	30		60	kOhm	Except RC2202: min 20, max 100 kOhm
1.8V regulated voltage at pin 29	1.7	1.8	1.9	V	

### Ordering Information

Ordering Part Number	Description
RC2200AT	ZigBee-ready RF module, 128 kB Flash, integrated antenna
RC2200MM	ZigBee-ready RF module, 128 kB Flash, MMCX connector
RC2200	ZigBee-ready RF module, 128 kB Flash (no antenna/connector)
RC2204AT	ZigBee-ready RF module, 64 kB Flash, integrated antenna
RC2204MM	ZigBee-ready RF module, 64 kB Flash, MMCX connector
RC2204	ZigBee-ready RF module, 64 kB Flash (no antenna/connector)
RC2202AT	ZigBee-ready RF module, 32 kB Flash, integrated antenna
RC2202MM	ZigBee-ready RF module, 32 kB Flash, MMCX connector
RC2202	ZigBee-ready RF module, 32 kB Flash (no antenna/connector)

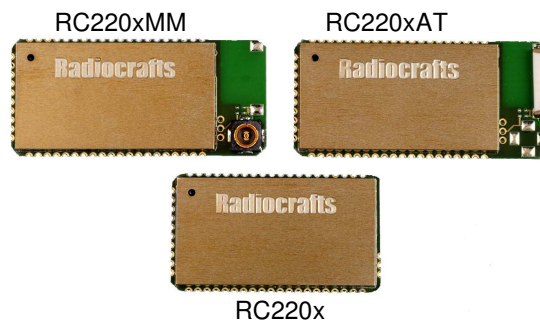

### Document Revision History

Document Revision	Changes
1.0	First release



### Product Status Definitions

Data Sheet Identification	Product Status	Definition
Preliminary	Engineering Samples and First Production	This data sheet contains preliminary data, and supplementary data will be published at a later date. Radiocrafts reserves the right to make changes at any time without notice in order to improve design and supply the best possible product.

### Disclaimer

Radiocrafts AS believes the information contained herein is correct and accurate at the time of this printing. However, Radiocrafts AS reserves the right to make changes to this product without notice. Radiocrafts AS does not assume any responsibility for the use of the described product; neither does it convey any license under its patent rights, or the rights of others. The latest updates are available at the Radiocrafts website or by contacting Radiocrafts directly.

As far as possible, major changes of product specifications and functionality, will be stated in product specific Errata Notes published at the Radiocrafts website. Customers are encouraged to check regularly for the most recent updates on products and support tools.

### Trademarks

ZigBee is a trademark of the ZigBee Alliance. All other trademarks, registered trademarks and product names are the sole property of their respective owners.

### Life Support Policy

This Radiocrafts product is not designed for use in life support appliances, devices, or other systems where malfunction can reasonably be expected to result in significant personal injury to the user, or as a critical component in any life support device or system whose failure to perform can be reasonably expected to cause the failure of the life support device or system, or to affect its safety or effectiveness. Radiocrafts AS customers using or selling these products for use in such applications do so at their own risk and agree to fully indemnify Radiocrafts AS for any damages resulting from any improper use or sale.

© 2005, Radiocrafts AS. All rights reserved.

### Contact Information

Web site: [www.radiocrafts.com](http://www.radiocrafts.com)

Email: [radiocrafts@radiocrafts.com](mailto:radiocrafts@radiocrafts.com)

Address:

**Radiocrafts AS**

Gunnar Schjelderups vei 11

NO-0485 OSLO

NORWAY

Tel: +47 970 86 676

Fax: +47 22 71 29 15

E-mail: [sales@radiocrafts.com](mailto:sales@radiocrafts.com)