

LH5P860

CMOS 512K (64K × 8) Pseudo-Static RAM

FEATURES

- 65,536 × 8 bit organization
- Access time: 80 ns (MAX.)
- Cycle time: 140 ns (MIN.)
- Single +5 V power supply
- Pin compatible with 1M standard SRAM
- Power consumption (MAX.):
 - Operating: 440 mW
 - Self refresh (TTL level): 5.5 mW
 - Self refresh (CMOS level): 2.75 mW
- TTL compatible I/O
- 512 refresh cycles/8 ms (MAX.)
- Available for auto-refresh and self-refresh modes
- Packages:
 - 32-pin, 600-mil DIP
 - 32-pin, 525-mil SOP

DESCRIPTION

The LH5P860 is a 512K-bit Pseudo-Static RAM organized as 65,536 × 8 bits. It is fabricated using silicon-gate CMOS process technology. With its built-in oscillator, it is easy to refresh memories without an external clock.

PIN CONNECTIONS

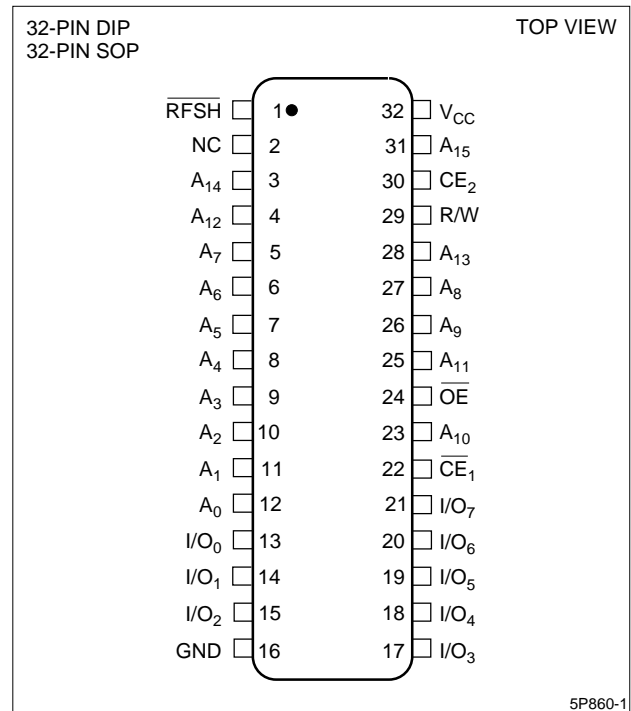

Figure 1. Pin Connections for DIP and SOP Packages

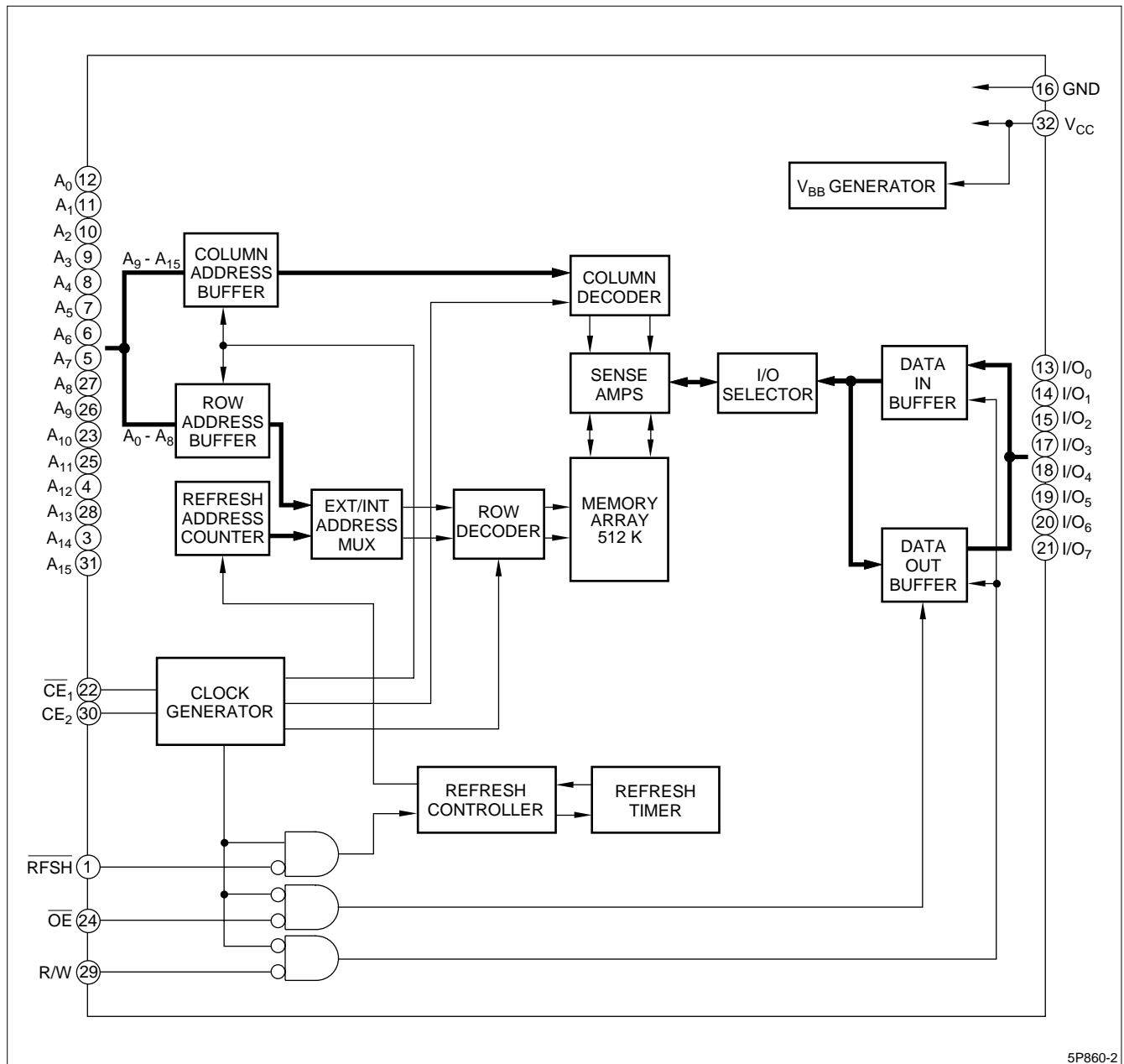

Figure 2. LH5P860 Block Diagram

PIN DESCRIPTION

SIGNAL	PIN NAME
A ₀ - A ₁₅	Address input
R/W	Read/Write input
OE	Output Enable input
RFSH	Refresh input
CE ₁ , CE ₂	Chip Enable input

SIGNAL	PIN NAME
I/O ₀ - I/O ₇	Data input/output
V _{CC}	Power Supply
GND	Ground
NC	No Connection

ABSOLUTE MAXIMUM RATINGS

PARAMETER	SYMBOL	RATING	UNIT	NOTE
Applied voltage on all pins	V_T	-1.0 to +7.0	V	1
Output short circuit current	I_O	50	mA	
Power dissipation	P_D	600	mW	
Operating temperature	T_{opr}	0 to +70	°C	
Storage temperature	T_{stg}	-65 to +150	°C	

NOTE:

1. The maximum applicable voltage on any pin with respect to GND.

RECOMMENDED OPERATING CONDITIONS ($T_A = 0$ to +70°C)

PARAMETER	SYMBOL	MIN.	TYP.	MAX.	UNIT
Supply voltage	V_{CC}	4.5	5.0	5.5	V
	GND	0	0	0	V
Input voltage	V_{IH}	2.4		$V_{CC} + 0.3$	V
	V_{IL}	-1.0		0.8	V

CAPACITANCE ($T_A = 0$ to +70°C, $f = 1$ MHz, $V_{CC} = 5.0$ V ±10%)

PARAMETER	CONDITIONS	SYMBOL	MIN.	MAX.	UNIT
Input capacitance	$A_0 - A_{15}$	C_{IN1}		8	pF
	R/W, OE, RFSH	C_{IN2}		5	pF
	CE_1, CE_2	C_{IN3}		5	pF
Input/Output capacitance	$I/O_0 - I/O_7$	C_{OUT1}		10	pF

DC CHARACTERISTICS ($T_A = 0$ to +70°C, $V_{CC} = 5.0$ V ±10%)

PARAMETER	SYMBOL	CONDITIONS	MIN.	MAX.	UNIT	NOTE
Average supply current in normal operation	I_{CC1}			80	mA	1, 2
Supply current in standby mode	I_{CC2}	TTL input		1.0	mA	1, 3
		CMOS input		0.5		1, 4
Average supply current in self refresh cycle	I_{CC3}	TTL input		1.0	mA	1, 5
		CMOS input		0.5		1, 6
Input leakage current	I_{LI}	$0\text{ V} \leq V_{IN} \leq 6.5\text{ V}$, 0 V except on test pins	-10	10	μA	
I/O leakage current	I_{LO}	$0\text{ V} \leq V_{OUT} \leq V_{CC} + 0.3\text{ V}$, Outputs in high-impedance state	-10	10	μA	
Output HIGH voltage	V_{OH}	$I_{OUT} = -1.0\text{ mA}$	2.4		V	
Output LOW voltage	V_{OL}	$I_{OUT} = 4.0\text{ mA}$		0.4	V	

NOTES:

1. Specified values are with outputs open.
2. I_{CC1} depends on the cycle time.
3. $CE_1 = V_{IH}$, RFSH = V_{IH} .
4. $CE_1 = V_{CC} - 0.2\text{ V}$, RFSH = $V_{CC} - 0.2\text{ V}$.
5. $CE_1 = V_{IH}$, RFSH = V_{IL} .
6. $CE_1 = V_{CC} - 0.2\text{ V}$, RFSH = 0.2 V.

AC CHARACTERISTICS ^{1, 2, 3} ($T_A = 0$ to $+70^\circ\text{C}$, $V_{CC} = 5.0\text{ V} \pm 10\%$)

PARAMETER	SYMBOL	MIN.	MAX.	UNIT	NOTE
Random read, write cycle time	t_{RC}	140		ns	
Read modify write cycle time	t_{RMW}	205		ns	
\overline{CE} pulse width	t_{CE}	80	10,000	ns	
\overline{CE} precharge time	t_P	50		ns	
Address setup time	t_{AS}	0		ns	4
Address hold time	t_{AH}	20		ns	4
Read command setup time	t_{RCS}	0		ns	
Read command hold time	t_{RCH}	0		ns	
\overline{CE} access time	t_{CEA}		80	ns	5
OE access time	t_{OEA}		30	ns	5
Output enable time from \overline{CE}	t_{CLZ}	20		ns	
Output enable time from \overline{OE}	t_{OLZ}	0		ns	
Output enable time from R/W	t_{WLZ}	0		ns	
Output disable time from \overline{CE}	t_{CHZ}		25	ns	
Output disable time from \overline{OE}	t_{OHZ}		25	ns	
Output disable time from R/W	t_{WHZ}		25	ns	
OE setup time	t_{OES}	10		ns	
\overline{OE} hold time	t_{OEH}	10		ns	
Write command pulse width	t_{WP}	30		ns	
Write command setup time	t_{WCS}	30		ns	
Write command hold time	t_{WCH}	50		ns	
Data setup time from R/W	t_{DSW}	30		ns	6
Data setup time from \overline{CE}	t_{DSC}	30		ns	6
Data hold time from R/W	t_{DHW}	0		ns	6
Data hold time from \overline{CE}	t_{DHC}	0		ns	6
Transition time (rise and fall)	t_T	3	35	ns	
Refresh time interval	t_{REF}		8	ms	
Refresh command hold time	t_{RHC}	15		ns	
Auto refresh cycle time	t_{FC}	130		ns	
Refresh delay time from \overline{CE}	t_{RFD}	50		ns	
Refresh pulse width (Auto refresh)	t_{FAP}	30	8,000	ns	
Refresh precharge time (Auto refresh)	t_{FP}	30		ns	
Refresh pulse width (Self refresh)	t_{FAS}	8,000		ns	
\overline{CE} delay time from refresh precharge (Self refresh)	t_{FRS}	160		ns	

NOTES:

- In order to initialize the circuit, an initialize pause of 100 μs with $\overline{CE}_1 = V_{IH}$, $\text{RFSH} = V_{IH}$ (or $\overline{CE}_2 = V_{IL}$, $\text{RFSH} = V_{IH}$) is required after power-up, followed by at least 8 dummy cycles.
- AC characteristics are measured at $t_T = 5$ ns.
- AC characteristics are measured at the following condition (see figure at right):
- Address is latched at the negative edge of \overline{CE}_1 or at the positive edge of \overline{CE}_2 .
- Measured with a load equivalent to 2TTL + 100 pF.
- Data is latched at the positive edge of R/W, at the positive edge of \overline{CE}_1 , or at the negative edge of \overline{CE}_2 .

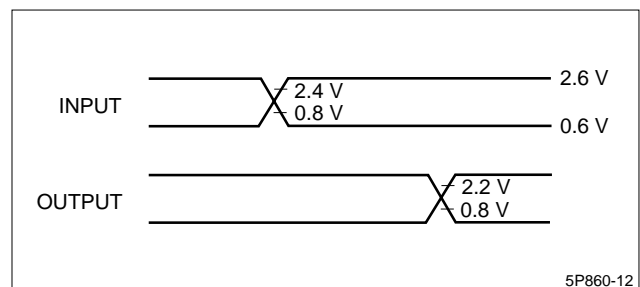
Figure 3. AC Characteristics

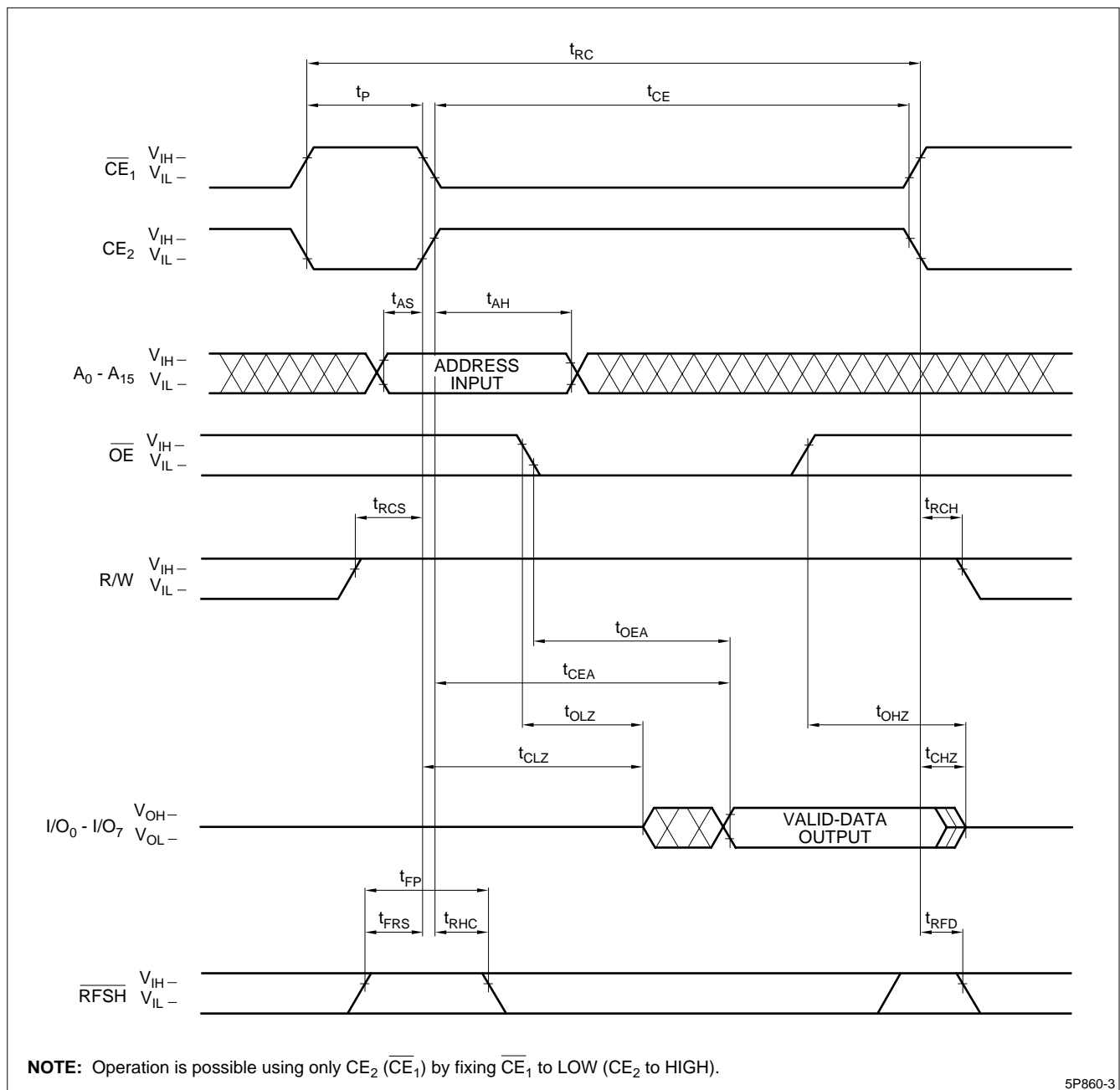

Figure 4. Read Cycle

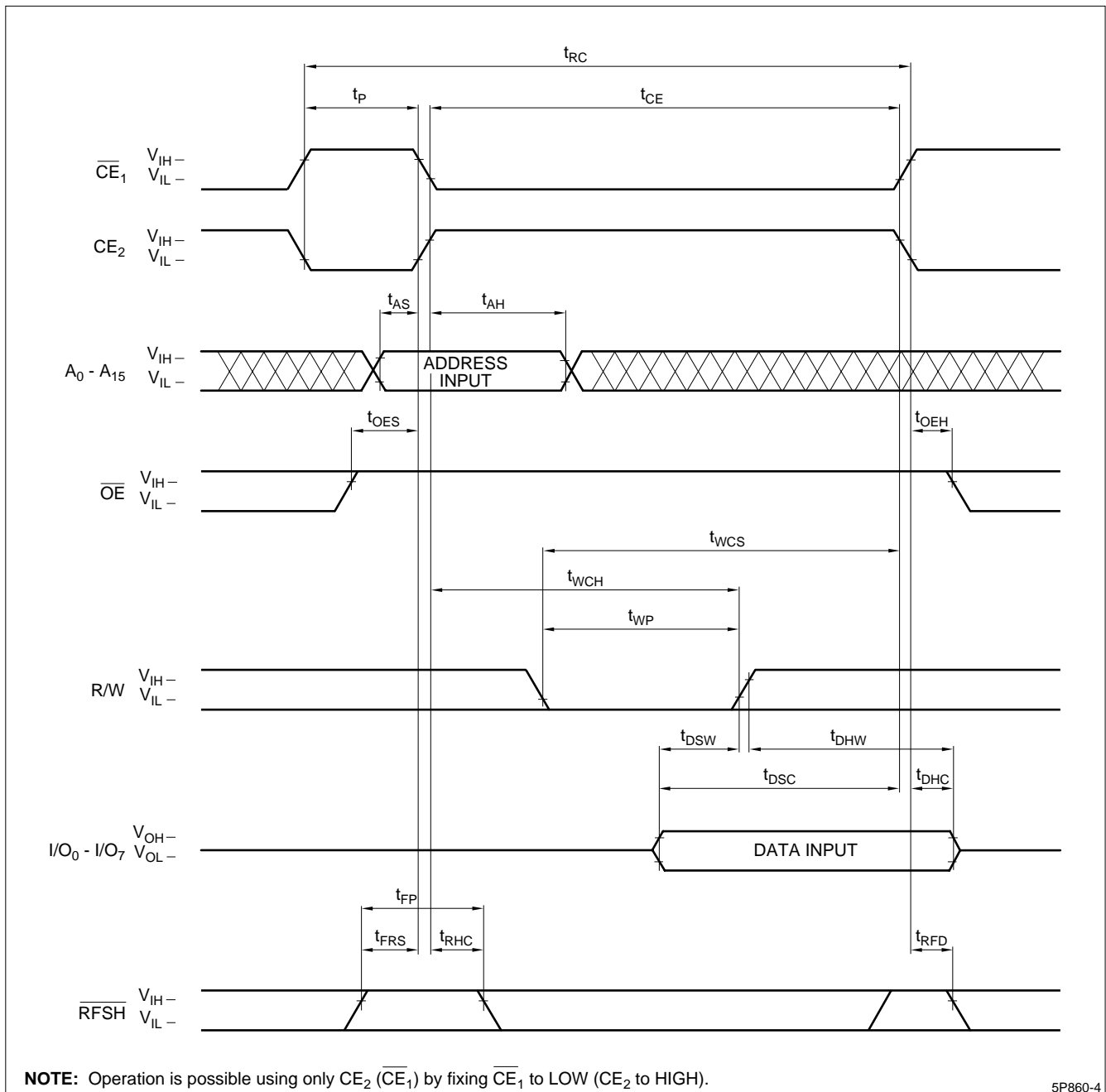

Figure 5. Write Cycle 1 (OE = Fix 'H')

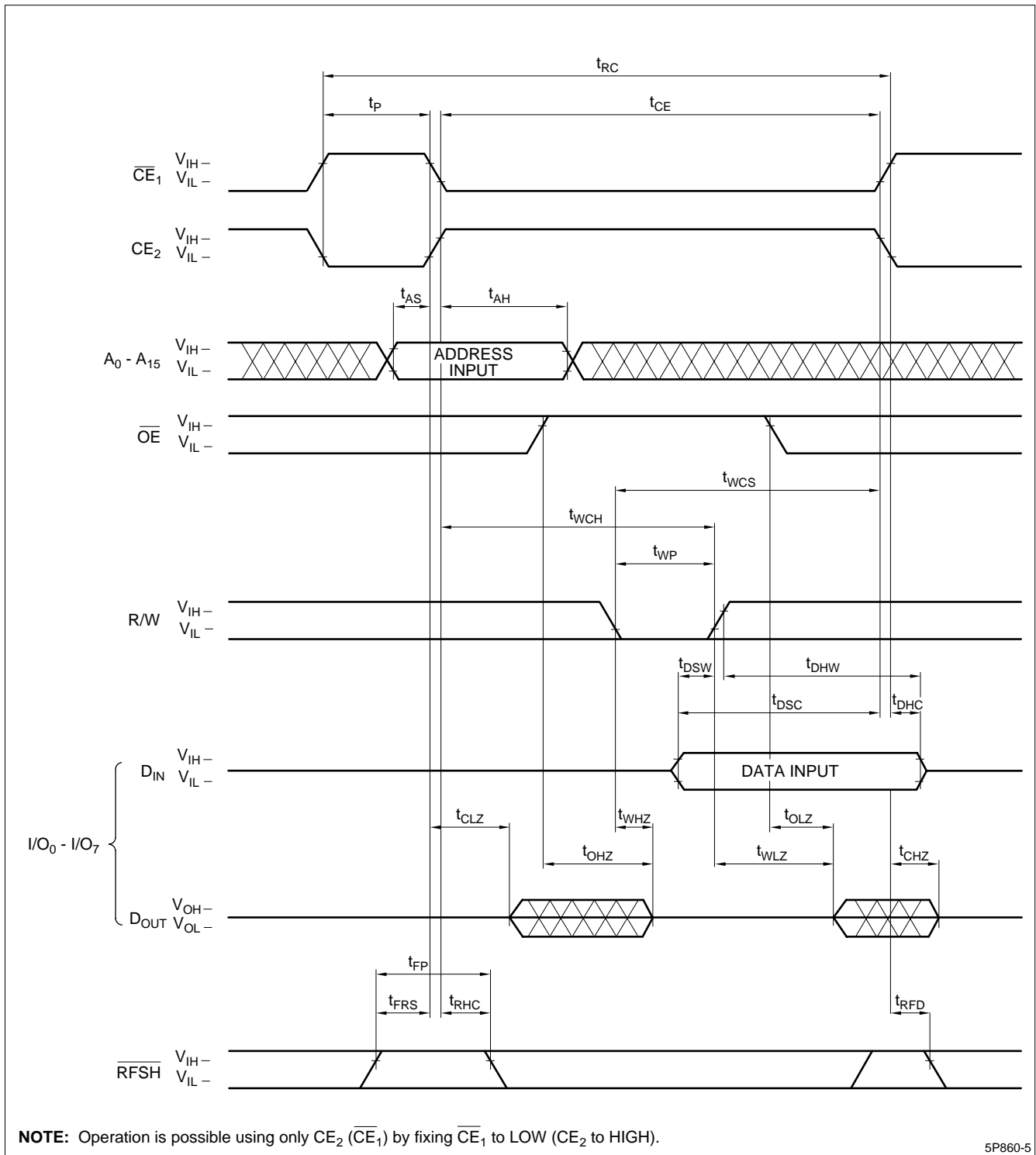

Figure 6. Write Cycle 2 (OE Clock)

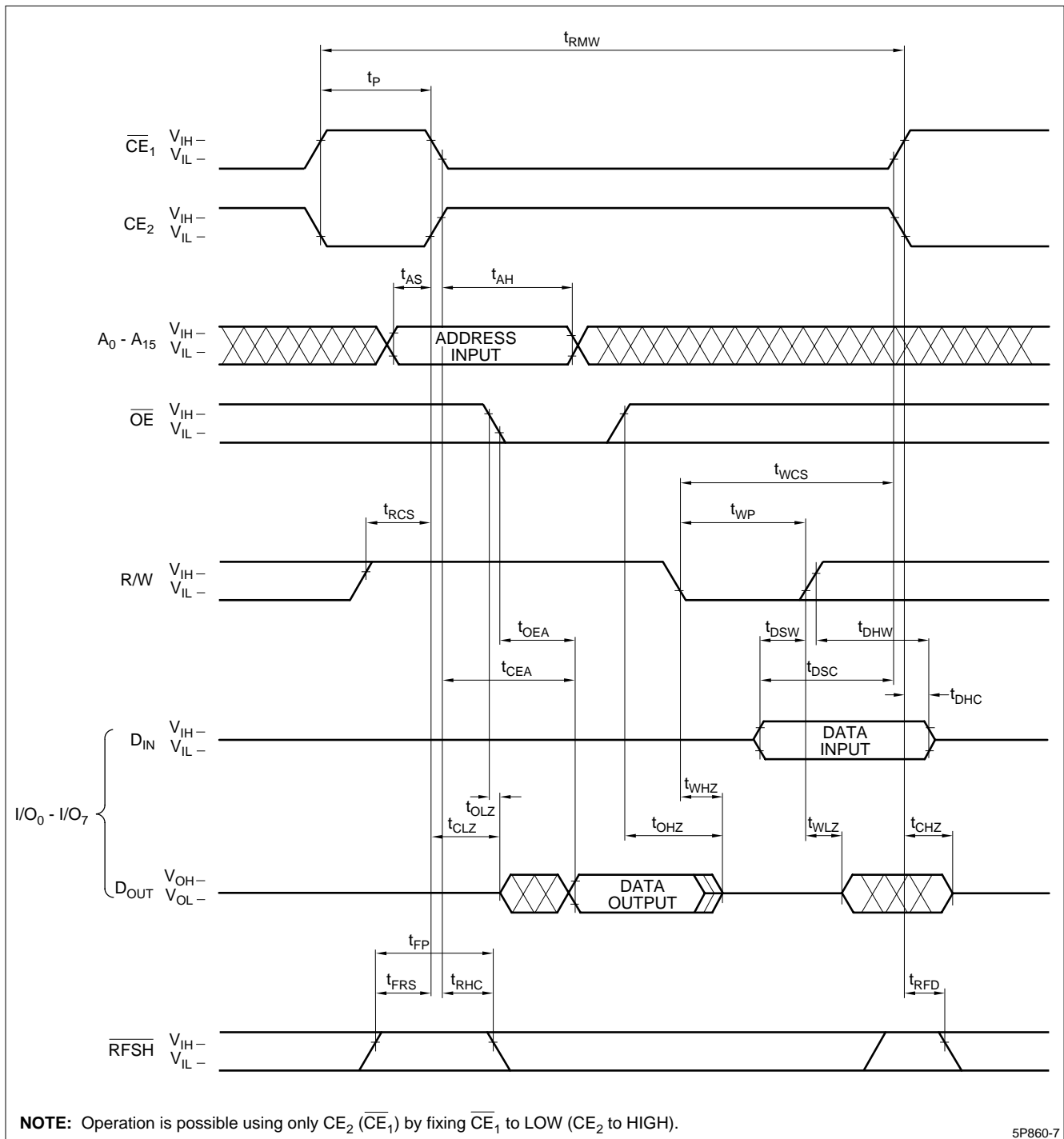

Figure 8. Read-Modify-Write Cycle

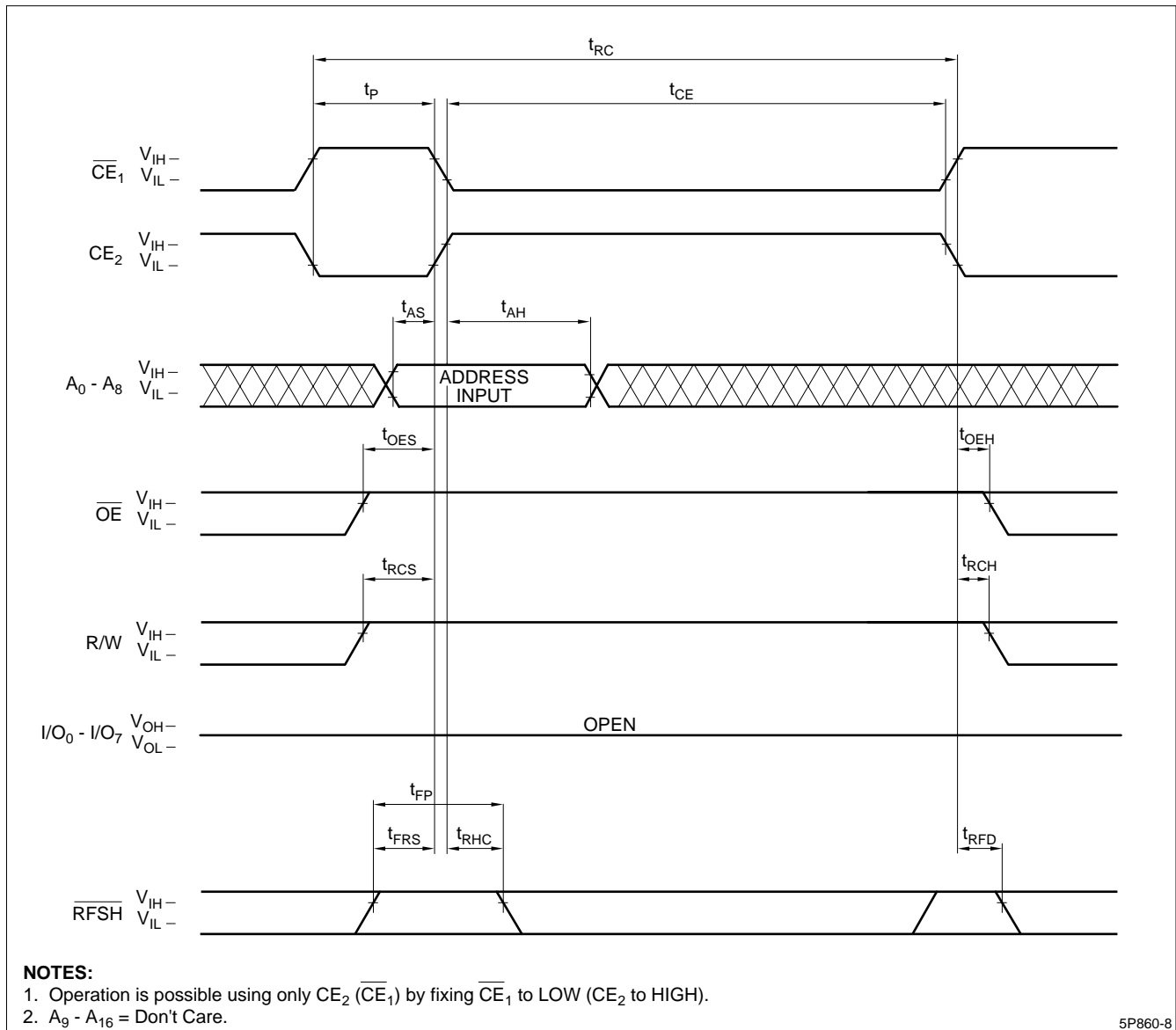

Figure 9. CE Only Refresh Cycle

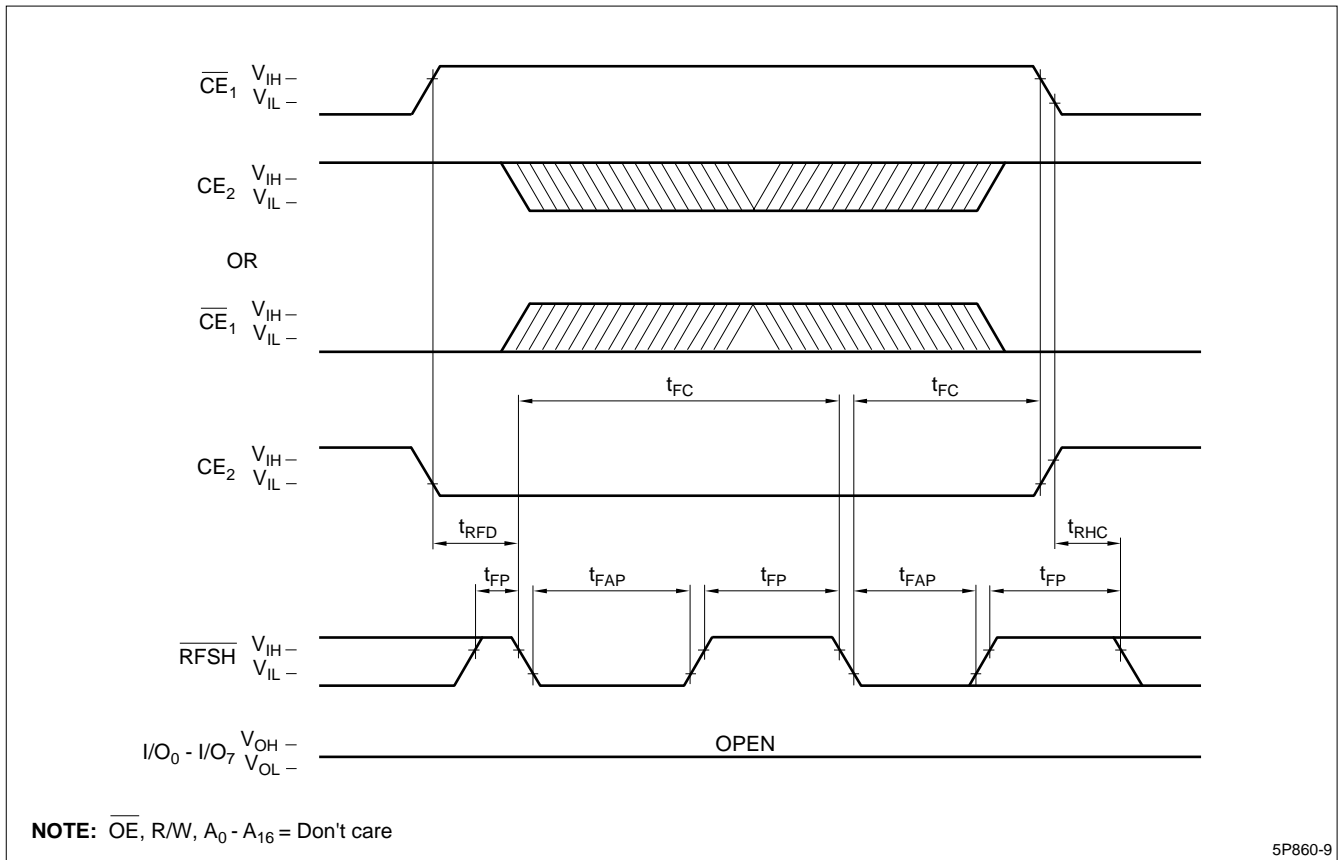

Figure 11. Auto Refresh Cycle

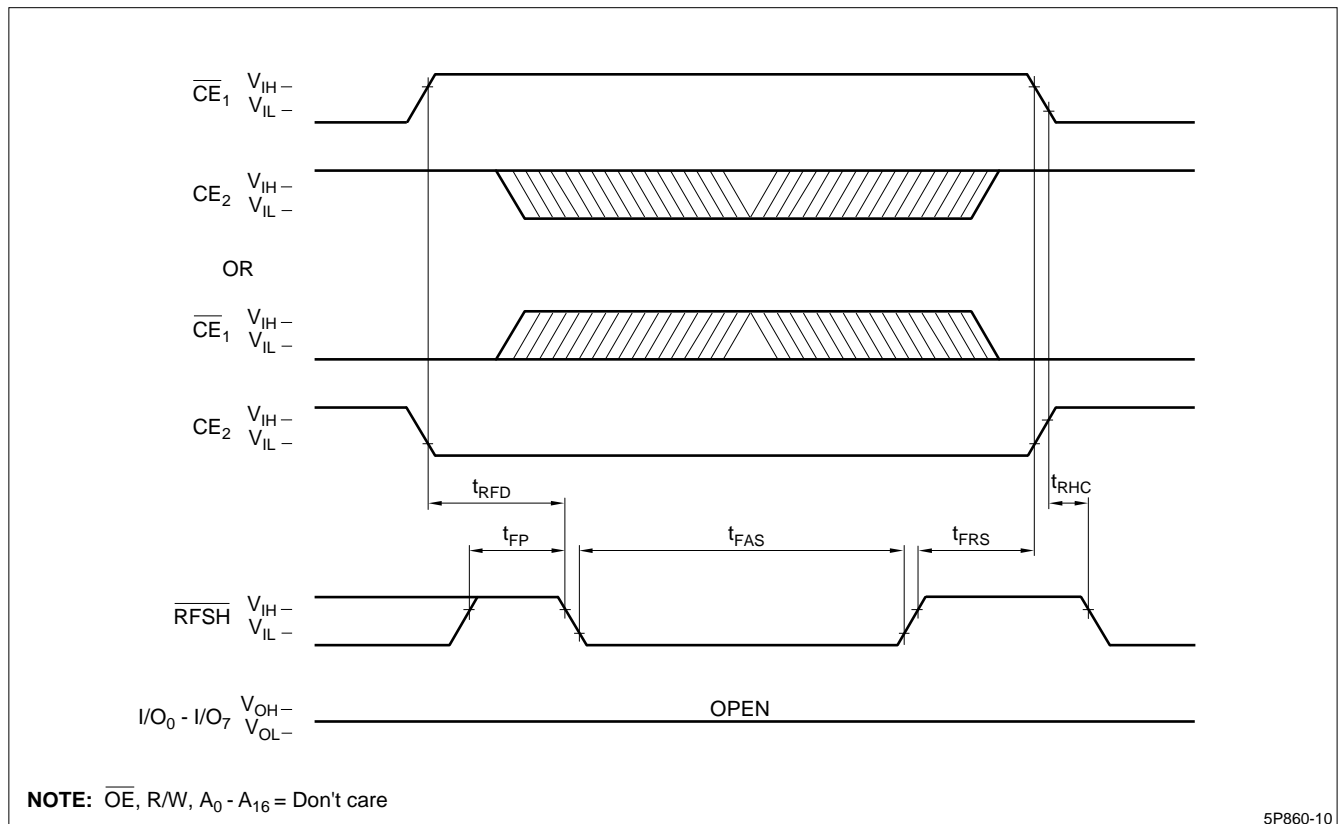
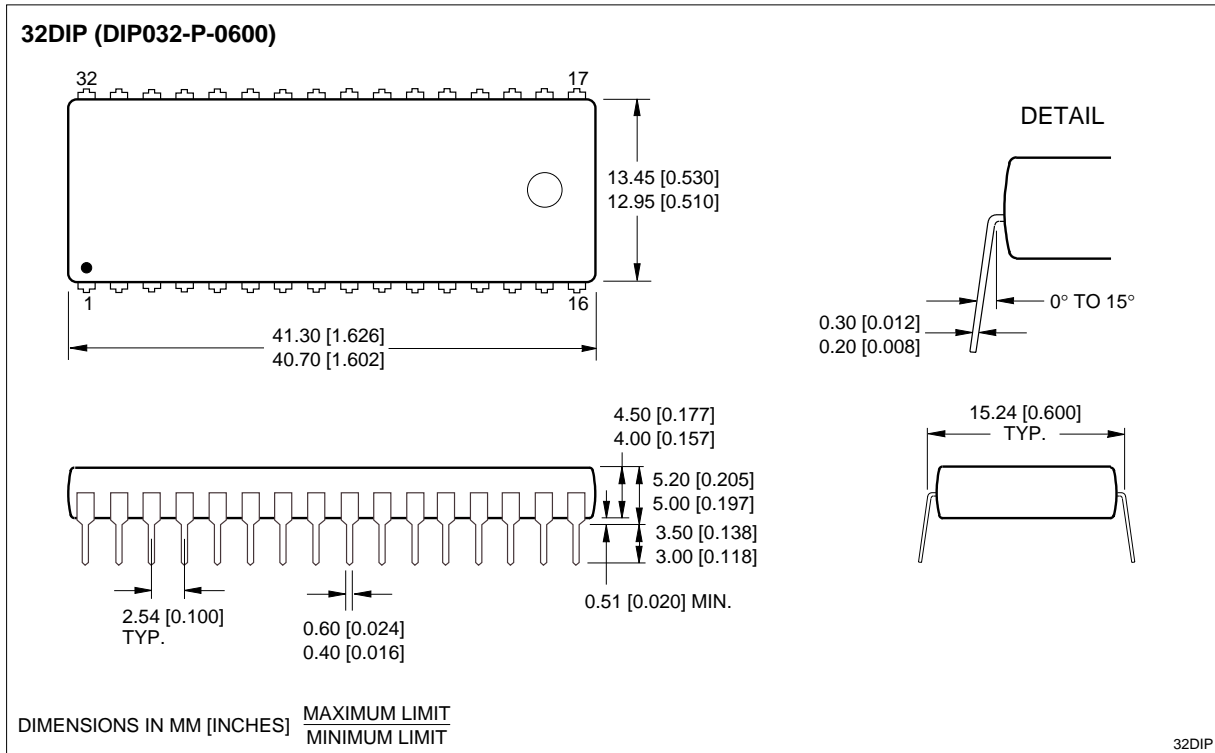
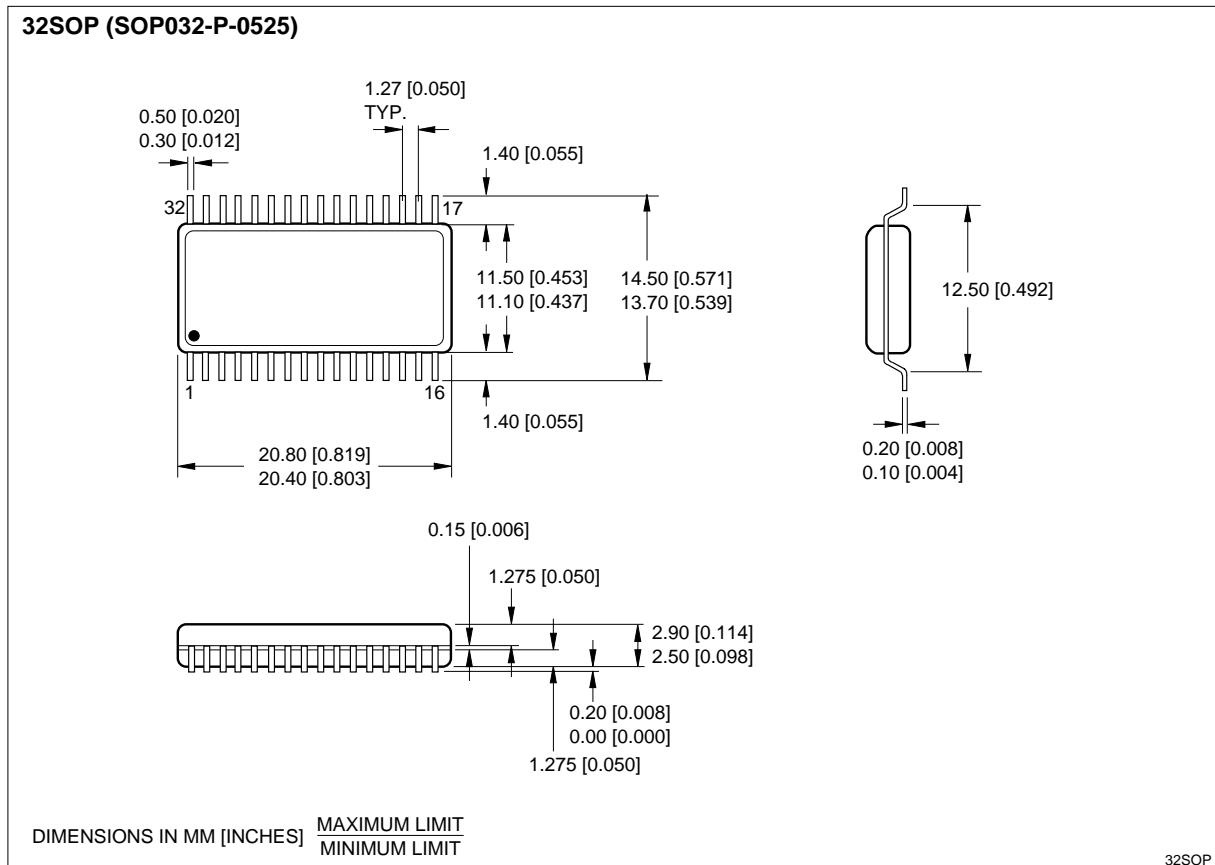

Figure 10. Self Refresh Cycle

PACKAGE DIAGRAMS



32-pin, 600-mil DIP



32-pin, 525-mil SOP

ORDERING INFORMATION

