

HIGH VOLTAGE NPN TRANSISTOR

APT17

General Description

The APT17 is high voltage, small signal NPN transistor.

The APT17 is available in SOT-23 and TO-92 packages.

Features

- High Collector-Emitter Voltage: 480V

Applications

- High Voltage and Low Standby Power Circuit for BCD Solution

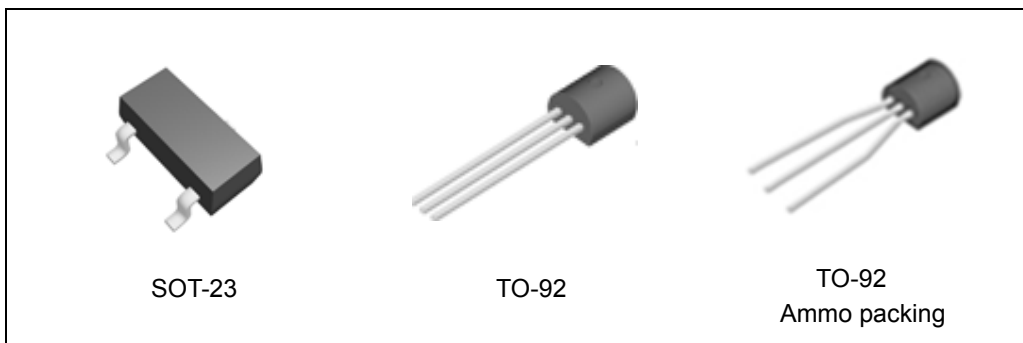

Figure 1. Package Types of APT17

Pin Configuration

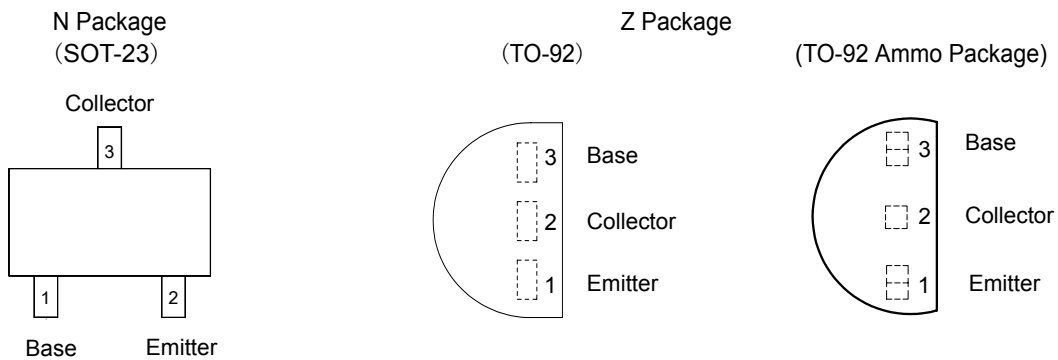
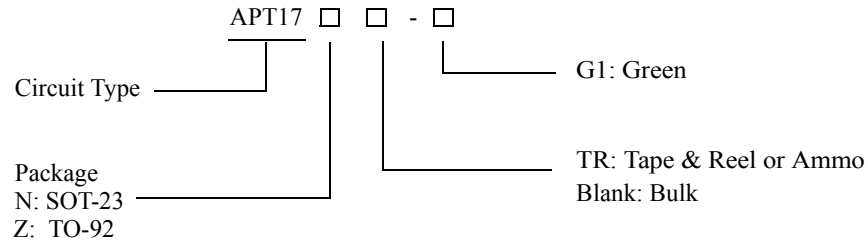

Figure 2. Pin Configurations of APT17 (Top View)

**HIGH VOLTAGE NPN TRANSISTOR****APT17****Ordering Information**

Package	Part Number	Marking ID	Packing Type
SOT-23	APT17NTR-G1	GD8	Tape & Reel
TO-92	APT17Z-G1	APT17Z-G1	Bulk
	APT17ZTR-G1	APT17Z-G1	Ammo

BCD Semiconductor's products, as designated with "G1" suffix in the part number, are RoHS compliant and Green.

Absolute Maximum Ratings (Note 1)

Parameter		Symbol	Value	Unit
Collector-Emitter Voltage ($V_{BE}=0$)		V_{CES}	700	V
Collector-Emitter Voltage ($I_B=0$)		V_{CEO}	480	V
Emitter-Base Voltage ($I_C=0$)		V_{EBO}	10	V
Collector Current		I_C	50	mA
Collector Peak Current (Pulse)		I_{CM}	100	mA
Base Current		I_B	25	mA
Base Peak Current (Pulse)		I_{BM}	50	mA
Power Dissipation, $T_A=25^\circ\text{C}$	SOT-23	P_{TOT}	0.2	W
	TO-92		0.5	
Operating Junction Temperature			150	$^\circ\text{C}$
Storage Temperature Range			-55 to 150	$^\circ\text{C}$

Note 1: Stresses greater than those listed under "Absolute Maximum Ratings" may cause permanent damage to the device. These are stress ratings only, and functional operation of the device at these or any other conditions beyond those indicated under "Recommended Operating Conditions" is not implied. Exposure to "Absolute Maximum Ratings" for extended periods may affect device reliability.

**HIGH VOLTAGE NPN TRANSISTOR****APT17****Thermal Characteristics**

Parameter	Symbol	Value	Unit
Thermal Resistance (Junction-to-Ambient)	SOT-23	625	°C/W
	TO-92	250	

Electrical Characteristics(T_C=25°C, unless otherwise specified.)

Parameter	Symbol	Conditions	Min	Typ	Max	Unit
Collector Cut-off Current (V _{BE} =-1.5V)	I _{CEV}	V _{CE} =700V			10	μA
Collector-Emitter Sustaining Voltage (I _B =0)	V _{CEO} (sus)	I _C =300μA	480			V
DC Current Gain	h _{FE}	I _C =300μA, V _{CE} =20V	20	25	40	
		I _C =10mA, V _{CE} =20V	20		50	



HIGH VOLTAGE NPN TRANSISTOR

APT17

Typical Performance Characteristics

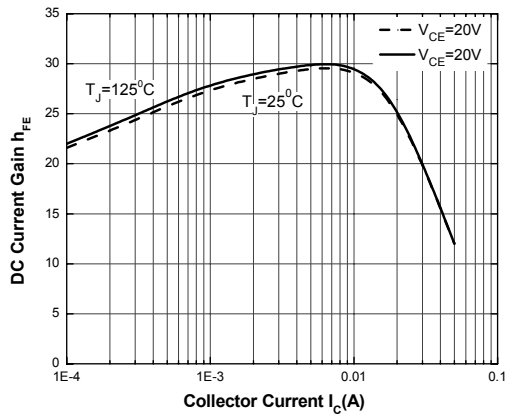

Figure 3. DC Current Gain

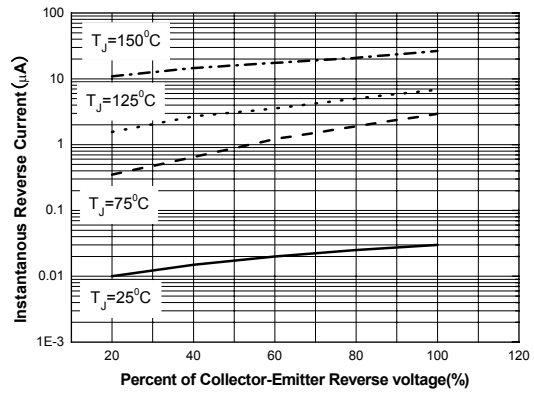

Figure 4. Typical Reverse Characteristics

HIGH VOLTAGE NPN TRANSISTOR

APT17

Mechanical Dimensions

SOT-23

Unit: mm(inch)

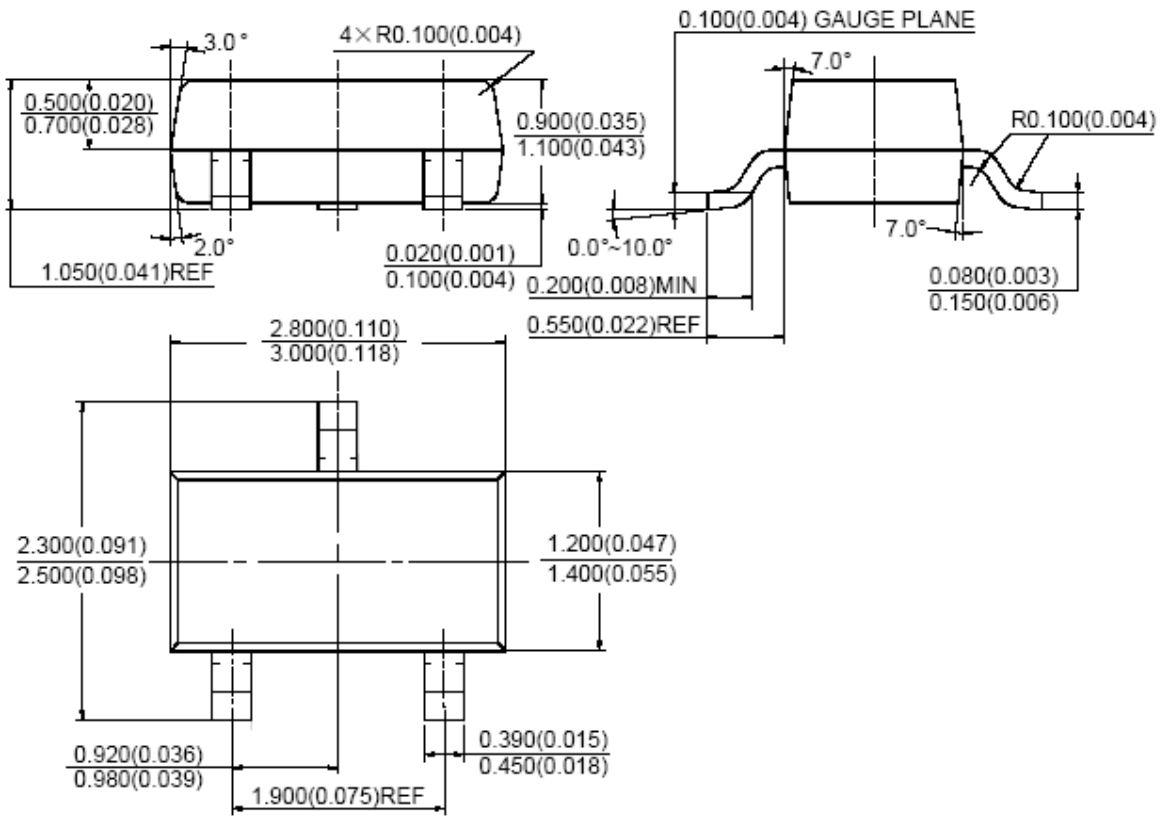

HIGH VOLTAGE NPN TRANSISTOR

APT17

Mechanical Dimensions (Continued)

TO-92

Unit: mm(inch)

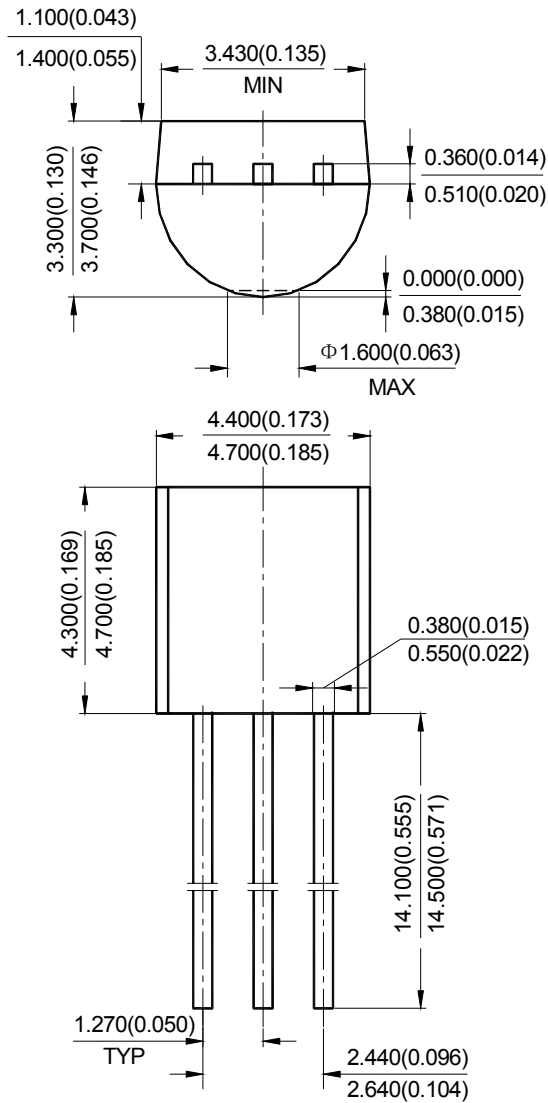



HIGH VOLTAGE NPN TRANSISTOR

APT17

Mechanical Dimensions (Continued)

TO-92 Ammo Packing

Unit: mm(inch)

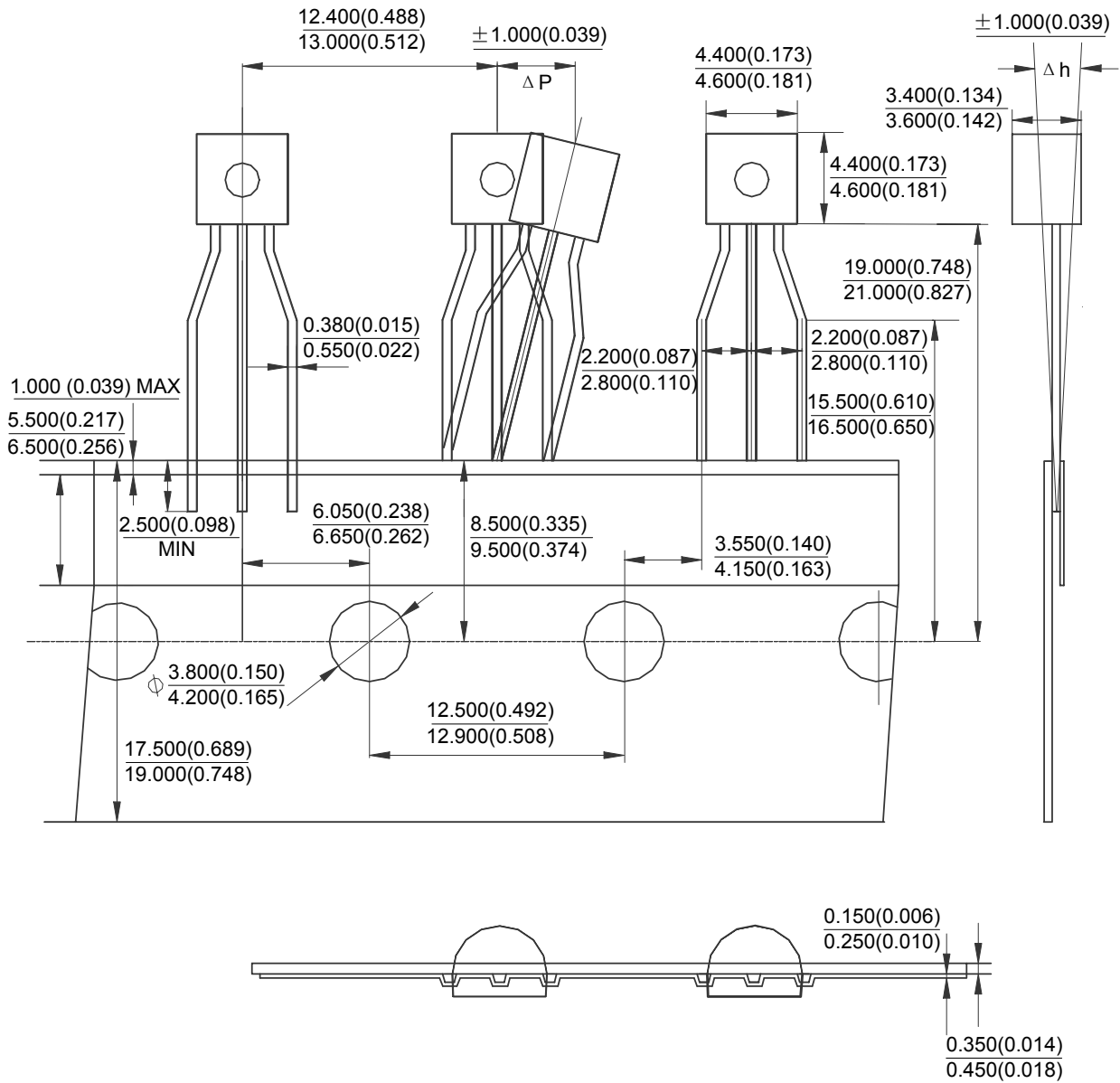

HIGH VOLTAGE NPN TRANSISTOR

APT17

Soldering Information

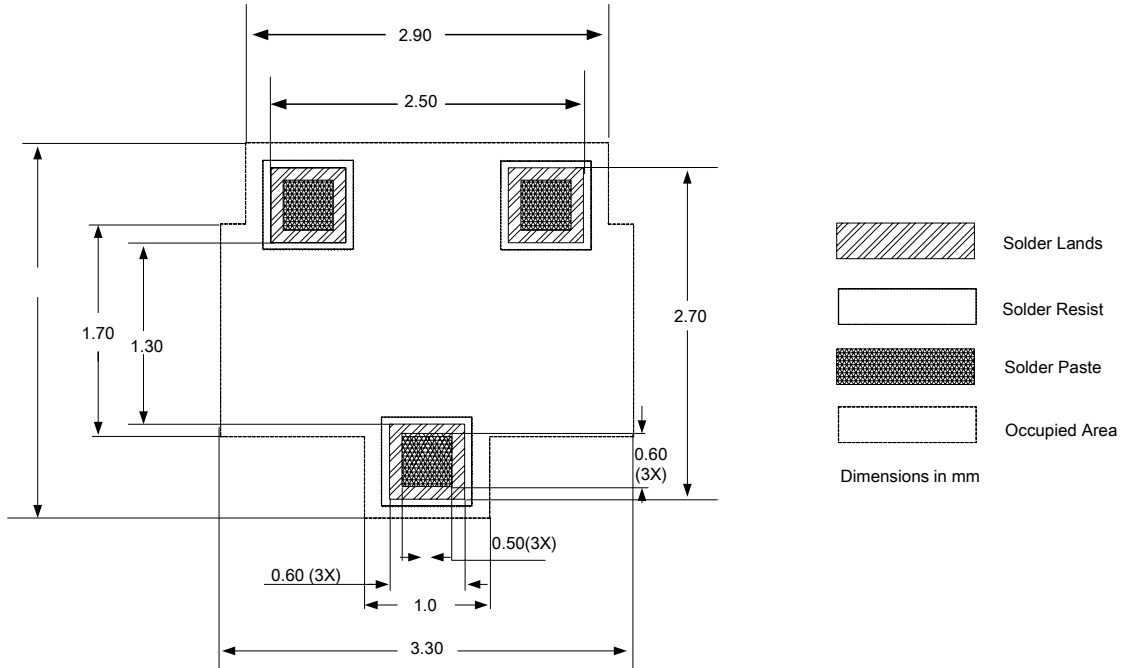

Figure 5. Reflow Soldering Footprint SOT-23

Soldering Information(Continued)

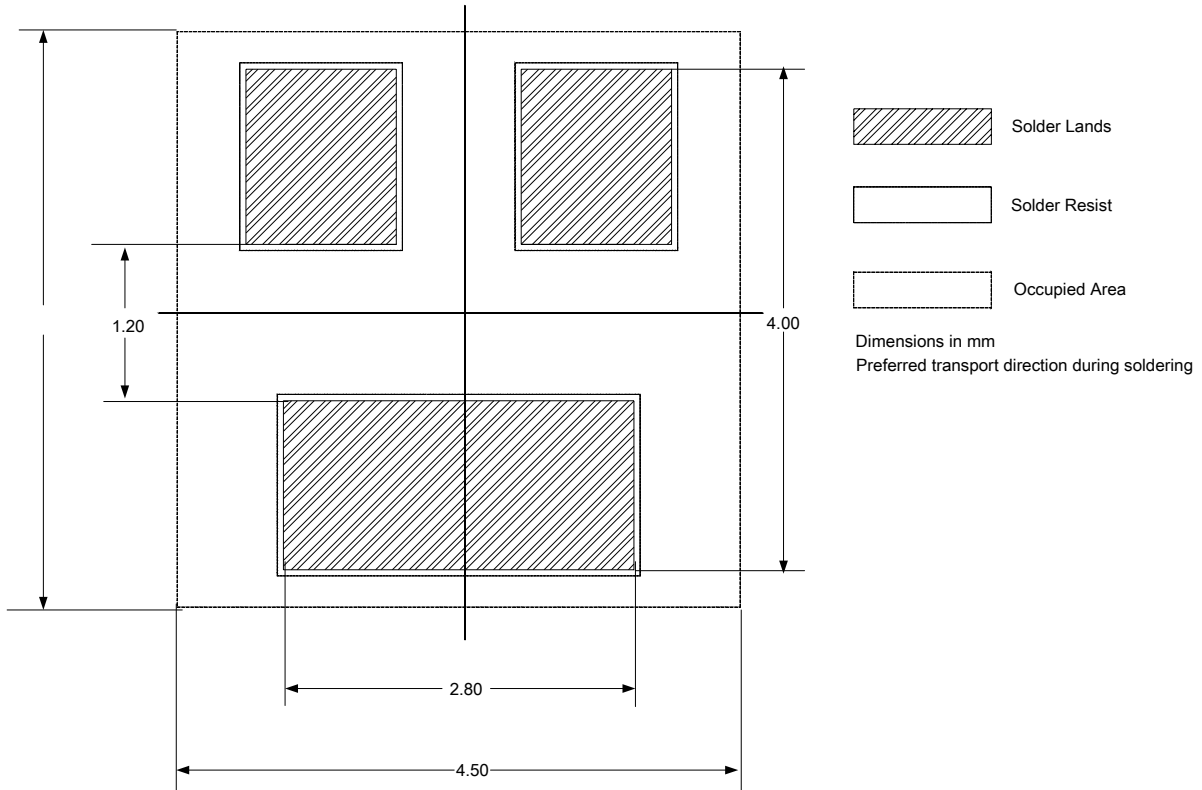

Figure 6. Waving Soldering Footprint SOT-23



BCD Semiconductor Manufacturing Limited

<http://www.bcdsemi.com>

IMPORTANT NOTICE

BCD Semiconductor Manufacturing Limited reserves the right to make changes without further notice to any products or specifications herein. BCD Semiconductor Manufacturing Limited does not assume any responsibility for use of any its products for any particular purpose, nor does BCD Semiconductor Manufacturing Limited assume any liability arising out of the application or use of any its products or circuits. BCD Semiconductor Manufacturing Limited does not convey any license under its patent rights or other rights nor the rights of others.

MAIN SITE

- Headquarters

BCD Semiconductor Manufacturing Limited

No. 1600, Zi Xing Road, Shanghai Zizhu Science-based Industrial Park, 200241, China
Tel: +86-21-24162266, Fax: +86-21-24162277

- Wafer Fab

Shanghai SIM-BCD Semiconductor Manufacturing Co., Ltd.

800 Yi Shan Road, Shanghai 200233, China
Tel: +86-21-6485 1491, Fax: +86-21-5450 0008

REGIONAL SALES OFFICE

Shenzhen Office

Shanghai SIM-BCD Semiconductor Manufacturing Co., Ltd., Shenzhen Office
Room E, 5F, Noble Center, No.1006, 3rd Fuzhong Road, Futian District, Shenzhen,
518026, China
Tel: +86-755-8826 7951
Fax: +86-755-8826 7865

Taiwan Office

BCD Semiconductor (Taiwan) Company Limited
4F, 298-1, Rui Guang Road, Nei-Hu District, Taipei,
Taiwan
Tel: +886-2-2656 2808
Fax: +886-2-2656 2806

USA Office

BCD Semiconductor Corp.
30920 Huntwood Ave. Hayward,
CA 94544, USA
Tel : +1-510-324-2988
Fax: +1-510-324-2788