

**3V GaAs HBT CDMA / WCDMA Cellular Power Amplifier Module**

**Functional Block Diagram**

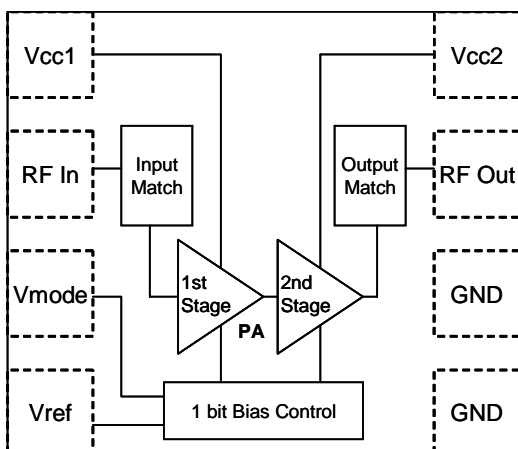

**Product Description**

The TQM713024 is a 3V, 2 stage GaAs HBT Power Amplifier Module designed for use in mobile phones. Its compact 3x3mm package makes it ideal for today's extremely small data enabled phones. Its RF performance meets the requirements for IS-95/98/CDMA2000 & WCDMA Rel99 standards.

The TQM713024 is designed on TriQuint's advanced InGaP HBT GaAs technology offering state of the art reliability, temperature stability and ruggedness. Selectable bias mode and a shutdown mode with low leakage current, improve talk and standby time. The output match, realized within the module package, optimizes efficiency/linearity at maximum rated output power. The TQM713024 has robust performance into mismatch and excellent linearity margin under all operating conditions including the ability to operate in LP Mode all the way to full output power.

**Electrical Specifications**

Parameter	Min	Typ	Max	Units
Frequency	824		849	MHz
CDMA mode maximum Pout <sup>1</sup>	28			dBm
CDMA ACPR1 (@ 885kHz Offset)		-50	-46	dBc
CDMA ACPR2 (@ 1.98MHz Offset)		-60	-56	dBc
PAE @ 28dBm	34	38		%
I <sub>LK</sub>		5		µA
Rx Band Noise		-137		dBm/Hz

*Test Conditions CDMA Mode: V<sub>CC1</sub>=3.4VDC, V<sub>CC2</sub>=3.4VDC, V<sub>REF</sub>=2.85VDC, T<sub>C</sub>=25°C*

**Data Sheet**

For additional information and latest specifications, see our website: [www.triquint.com](http://www.triquint.com)  
Revision F, August 10, 2006

**Features**

- InGaP HBT Technology
- High Efficiency: 38% @ 28dBm
- Capable of running as 0-bit PA in low bias mode to 28dBm
- Supports new chipsets with Vref@2.6V
- Optimized for 50 ohm System
- Small 8-pin, 3x3mm module
- Excellent Rx band noise performance
- Lead-free 260°C RoHS Compliant
- Full ESD Protection

**Applications**

- IS-95/CDMA2000
- Single/Dual/Tri Mode CDMA/AMPS phones

**Package Style**

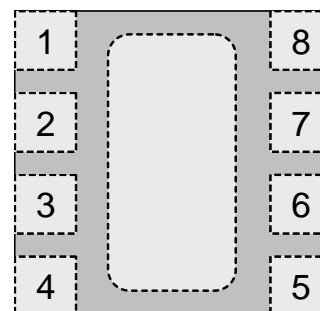

8-Pin 3.0x3.0mm Plastic Module Package  
Top View (X-ray)

Note 1:

## 3V GaAs HBT CDMA / WCDMA Cellular Power Amplifier Module

### Electrical Specifications

#### Absolute Maximum Ratings<sup>1</sup>

Parameter	Symbol	Min.	Typ/Nom	Max.	Units
RF Input Power	P <sub>IN</sub>	-	0 for HPM 2 for LPM	10.0	dBm
Supply Voltage	V <sub>CC</sub>	0	3.4	5.0	Volts
Reference Voltage	V <sub>REF</sub>	0	2.85	3.5	Volts
Vmode (1 bit Bias Control)	Vmode	0	-	3.5	Volts
Case Operating Temperature	T <sub>CASE</sub>	-40	25	+100	°C
Storage Temperature	T <sub>STORE</sub>	-55	25	+150	°C

Note 1: No damage assuming only one parameter is set at a time with all other parameters set at or below nominal value.

#### Recommended Operating Conditions

Parameter	Symbol	Min.	Typ/Nom	Max.	Units
Supply Voltage	V <sub>CC</sub>	3.2	3.4	4.2	Volts
Reference Voltage	V <sub>REF</sub>				Volts
PA On		2.75	2.85	2.95	
PA Off		0	-	0.5	
Vmode (1 bit Bias Control)	Vmode				Volts
High Bias Mode		0	-	0.5	
Low Bias Mode		2.5	2.85	3.0	
Case Operating Temperature	T <sub>CASE</sub>	-30	25	+85	°C

Note 1: No damage assuming only one parameter is set at a time with all other parameters set at or below nominal value.

#### Power Range Truth Table

Parameter	V <sub>Ref</sub>	Vmode	Range
High Power	2.85 V	Low	16 dBm - 28 dBm
Low Power	2.85 V	High	< 16 dBm
Shut Down	0 V	Low	-

#### Data Sheet

For additional information and latest specifications, see our website: [www.triquint.com](http://www.triquint.com)  
Revision F, August 10, 2006

**3V GaAs HBT CDMA / WCDMA Cellular Power Amplifier Module**

*CDMA (IS-98C) Electrical Characteristics<sup>1,3</sup>*

Parameter	Conditions	Min.	Typ/Nom	Max.	Units
RF Frequency		824		849	MHz
Large Signal Gain <sup>4</sup>					
<ul style="list-style-type: none"> <li>+16dBm ≤ Pout ≤ +28dBm</li> <li>Pout ≤ +16dBm</li> </ul>	Vcc=3.4V; Vref=2.85V; -30°C<Temp<85°C	24.5 23	28 26	29.5 28	dB
Adjacent Channel Power (ACPR1) <sup>2,4</sup>					
<ul style="list-style-type: none"> <li>+16dBm ≤ Pout ≤ +28dBm</li> <li>Pout ≤ +16dBm</li> </ul>	Vcc=3.4V; Vref=2.85V; -30°C<Temp<85°C		-50 -53	-46 -46	dBc
Alternate Channel Power (ACPR2) <sup>2,4</sup>					
<ul style="list-style-type: none"> <li>+16dBm ≤ Pout ≤ +28dBm</li> <li>Pout ≤ +16dBm</li> </ul>	Vcc=3.4V; Vref=2.85V; -30°C<Temp<85°C		-59 -62	-56 -56	dBc
Quiescent Current					
<ul style="list-style-type: none"> <li>Low bias Mode</li> <li>High bias Mode</li> </ul>	Vcc=3.4V; Vref=2.85V; Temp=25°C		58 110		mA
I <sub>REF</sub>	Pout = +28dBm, Vcc=3.4V; Vref=2.85V; Vmode=0V; Temp=25°C		2.5	4	mA
I <sub>TOTAL</sub>	Pout = +28dBm, Vcc=3.4V; Vref=2.85V; Vmode=0V; Temp=25°C		485		mA
Input VSWR	All terminals		1.5:1	2.0:1	
PAE					
<ul style="list-style-type: none"> <li>Pout = 28dBm</li> <li>Pout = 16dBm</li> </ul>	Vcc=3.4V; Vref=2.85V; Temp=25°C	34 7	38 9		%
Noise Power in Rx band	Pout=+28dBm, IS-95 Standard		-137	-134	dBm/Hz
Harmonics					
<ul style="list-style-type: none"> <li>2fo</li> <li>3fo</li> </ul>	Pout ≤ +28dBm		-50 -65	-40 -40	dBc
Spurious/Stability	10:1 VSWR (all phases) no oscillations. All harmonic spurious			-65	dBc
Ruggedness	10:1 VSWR, 10dBm Pin all phases	No degradation in performance and no permanent damage to device			

*Note 1: Typical Test Conditions: V<sub>CC</sub>=3.4VDC, V<sub>REF</sub>=2.85VDC, T<sub>C</sub> = +25°C, TriQuint Test Board.*

*Note 2: ACPR1 measured @ ± 885kHz offset; ACPR2 measured @ ± 1.98MHz offset*

*Note 3: Operation in LP mode to +28dBm is possible while maintaining ACPR1 specifications to improve overall efficiency*

*Note 4: P<sub>OUT</sub>=27.5dBm at +85°C*

**Data Sheet**

For additional information and latest specifications, see our website: [www.triquint.com](http://www.triquint.com)

Revision F, August 10, 2006

## 3V GaAs HBT CDMA / WCDMA Cellular Power Amplifier Module

### WCDMA Rel99 Electrical Characteristics<sup>1,3,4</sup>

Parameter	Conditions	Min.	Typ/Nom	Max.	Units
RF Frequency		824		849	MHz
Large Signal Gain <sup>5</sup>					
<ul style="list-style-type: none"> <li>+16dBm ≤ Pout ≤ +28dBm</li> <li>Pout ≤ +16dBm</li> </ul>	Vcc=3.4V; Vref =2.85V; -30°C<Temp<85°C	25 24	28 26	30	dB
Adjacent Channel Power (ACPR1) <sup>2,5</sup>					
<ul style="list-style-type: none"> <li>+16dBm ≤ Pout ≤ +28dBm</li> <li>Pout ≤ +16dBm</li> </ul>	Vcc=3.4V; Vref =2.85V; -30°C<Temp<85°C		-45 -44	-36 -36	dBc
Alternate Channel Power (ACPR2) <sup>2,5</sup>					
<ul style="list-style-type: none"> <li>+16dBm ≤ Pout ≤ +28dBm</li> <li>Pout ≤ +16dBm</li> </ul>	Vcc=3.4V; Vref =2.85V; -30°C<Temp<85°C		-60 -60	-57 -57	dBc
Quiescent Current					
<ul style="list-style-type: none"> <li>Low bias Mode</li> <li>High bias Mode</li> </ul>	Vcc=3.4V; Vref=2.85V; Temp=25°C		58 110		mA
I <sub>REF</sub>	Pout = +27.5dBm, Vcc=3.4V; Vref=2.85V; Vmode=0V; Temp=25°C		2.5	4	mA
I <sub>TOTAL</sub>	Pout = +28dBm, Vcc=3.4V; Vref=2.85V; Vmode=0V; Temp=25°C		475		mA
Input VSWR	All terminals		1.5:1	2.0:1	
PAE					
<ul style="list-style-type: none"> <li>Pout = 28dBm</li> <li>Pout = 16dBm</li> </ul>	Vcc=3.4V; Vref=2.85V; Temp=25°C		39 9		%
Noise Power in Rx band	Pout=+28dBm, IS-95 Standard		-137	-134	dBm/Hz
Harmonics					
<ul style="list-style-type: none"> <li>2fo</li> <li>3fo</li> </ul>	Pout ≤ +28dBm		-50 -65	-40 -40	dBc
Spurious/Stability	10:1 VSWR (all phases) no oscillations. All harmonic spurious			-65	dBc

**Note 1:** Typical Test Conditions: V<sub>CC</sub>=3.4VDC, V<sub>REF</sub>=2.85VDC, T<sub>C</sub> = +25°C, TriQuint Test Board

**Note 2:** ACPR1 measured @ ± 5 MHz offset; ACPR2 measured @ ± 10 MHz offset

**Note 3:** Tested under Rel99 modulation

**Note 4:** Operation to Pout=29dBm in HP mode is possible while maintaining ACPR1/ACPR2 specifications, PAE = 43%@29dBm

**Note 5:** P<sub>OUT</sub>=27.5dBm at +85°C

#### Data Sheet

For additional information and latest specifications, see our website: [www.triquint.com](http://www.triquint.com)

Revision F, August 10, 2006

**3V GaAs HBT CDMA / WCDMA Cellular Power Amplifier Module**

*Typical Performance*

Test Conditions (Unless Otherwise Specified):  $V_{CC}=3.4VDC$ ,  $V_{REF}=2.85VDC$ ,  $V_{MODE}=0$  or  $2.85VDC$ ,  $P_{OUT}=28.0$  or  $16dBm$

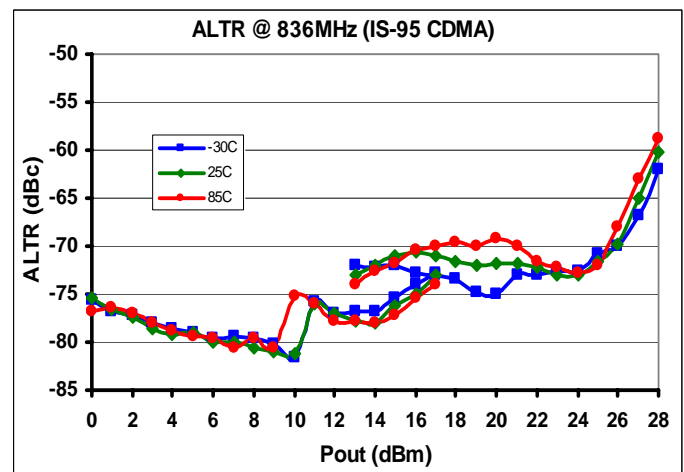
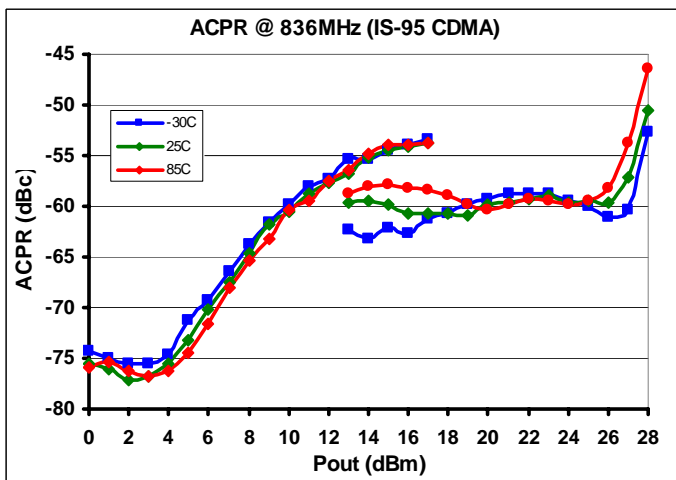
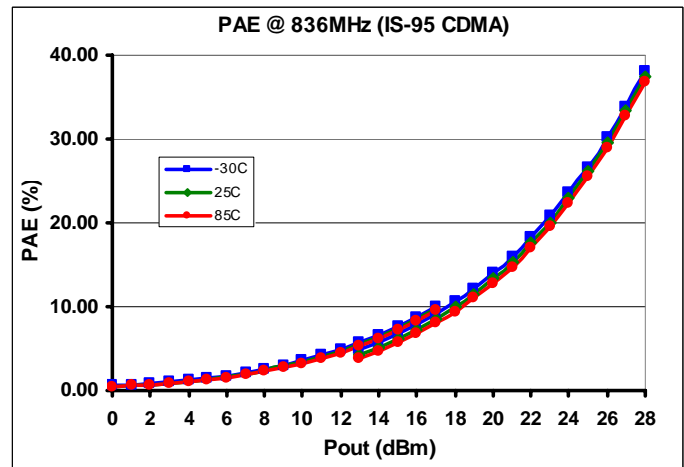
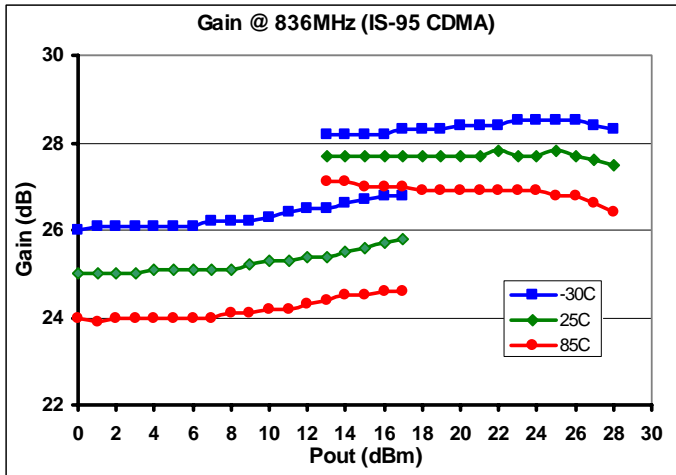

*Data Sheet*

For additional information and latest specifications, see our website: [www.triquint.com](http://www.triquint.com)  
Revision F, August 10, 2006

**3V GaAs HBT CDMA / WCDMA Cellular Power Amplifier Module**

Typical Performance (Continued)

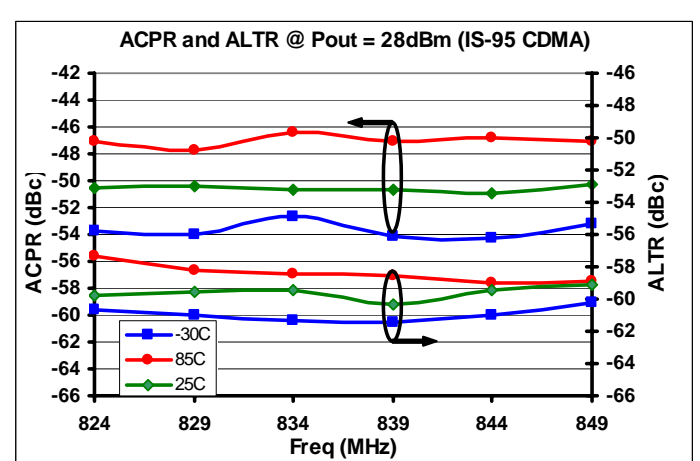
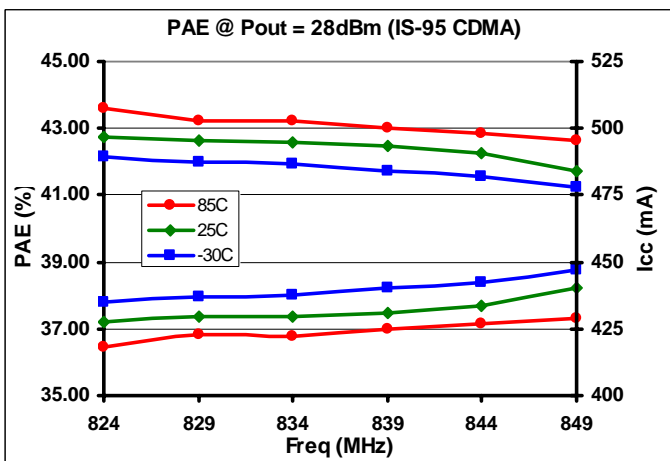
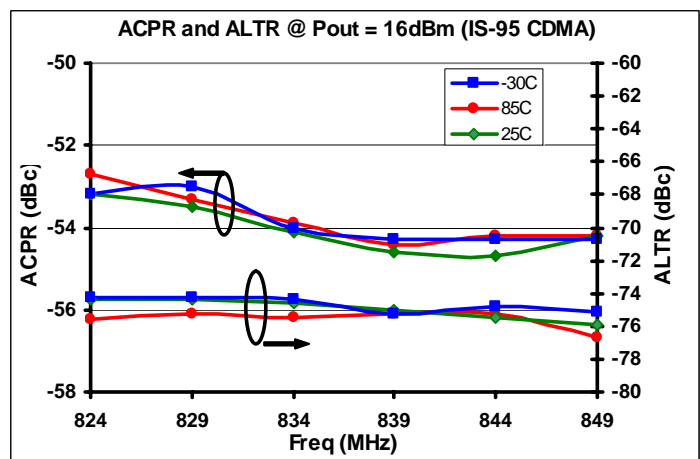
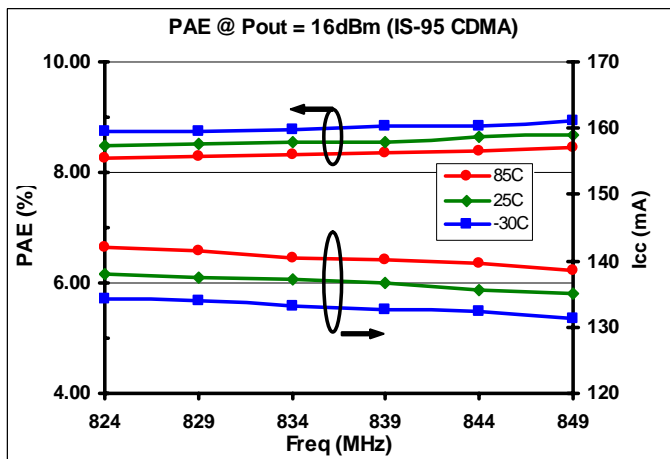
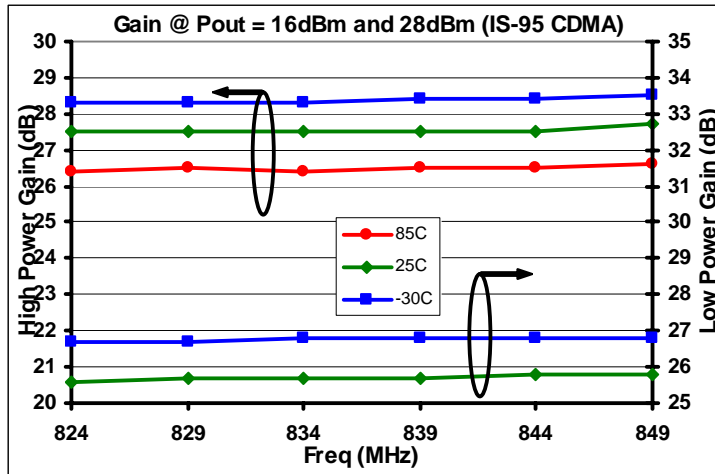

Data Sheet

For additional information and latest specifications, see our website: [www.triquint.com](http://www.triquint.com)

Revision F, August 10, 2006

**3V GaAs HBT CDMA / WCDMA Cellular Power Amplifier Module**

**Evaluation Board**

TriQuint offers our customers the below evaluation board as a means for testing and analysis of TQM713024. The evaluation board schematic and picture are provided for preliminary analysis and design. Figure 1 shows the TriQuint application board, while Figure 2 shows the schematic of the board.

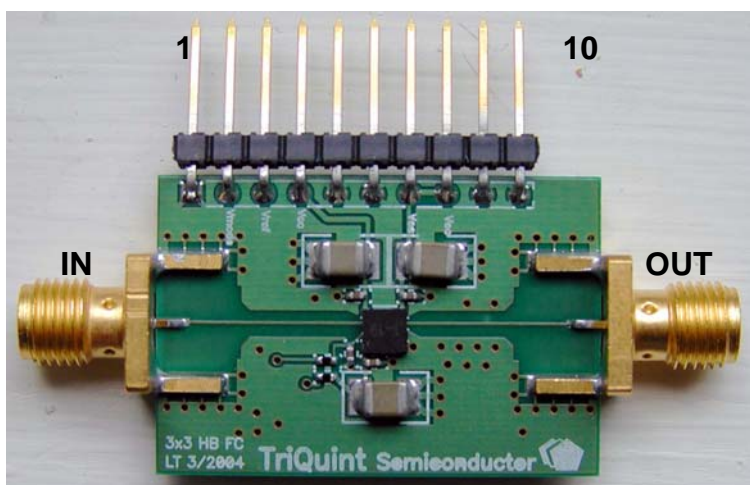

Pin #	Function
1	GND, DC Ground
2	Vmode, High/low Bias Mode
3	Vref, Reference Voltage
4	Vcc1, 1 <sup>st</sup> Stage Collector Voltage
5	GND, DC Ground
6	GND, DC Ground
7	Vcc2, 2 <sup>nd</sup> Stage Collector Voltage
8	Vcc2, 2 <sup>nd</sup> Stage Collector Voltage
9	GND, DC Ground
10	GND, DC Ground

Figure 1: Evaluation Board Assembly Diagram

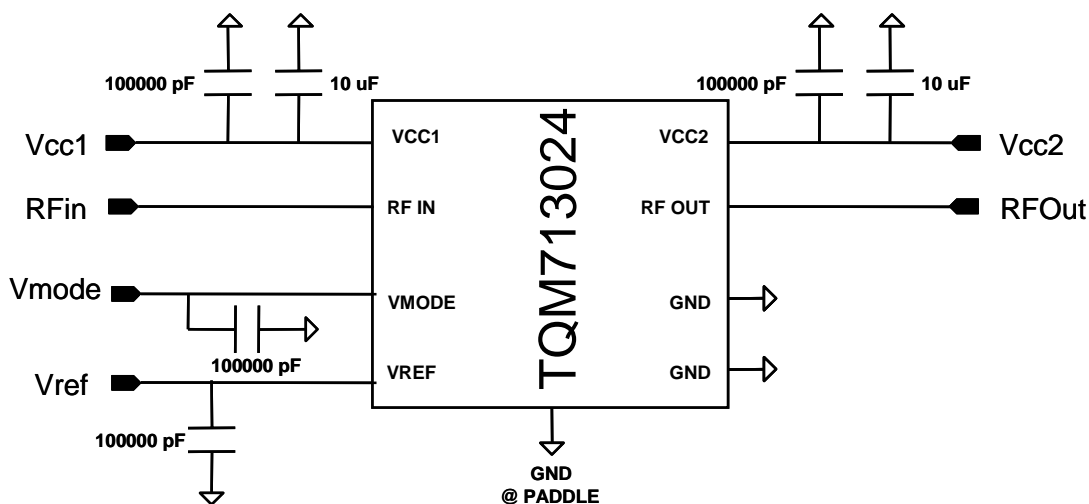

Figure 2: Evaluation Board Schematic

**Data Sheet**

For additional information and latest specifications, see our website: [www.triquint.com](http://www.triquint.com)  
Revision F, August 10, 2006



**3V GaAs HBT CDMA / WCDMA Cellular Power Amplifier Module**

**Packaging Characteristics**

Package Pin-Out:

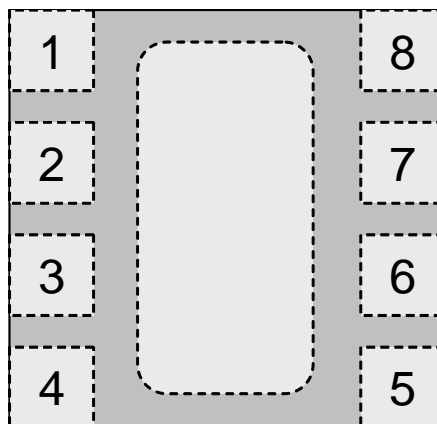

Figure 3: Package Pin-Out Identification Drawing  
Top View (X-ray)

Note: TriQuint recommends use of several via holes to the backside ground under the Paddle.

Pin #	Description	Function
1	VCC1	Power supply to 1 <sup>st</sup> stage of PA
2	RF IN	RF input
3	VMODE	1-bit bias control
4	VREF	Bias reference voltage
5	GND	Ground
6	GND	Ground
7	RF OUT	RF Output
8	VCC2	Power supply to 2 <sup>nd</sup> stage of PA

Data Sheet

For additional information and latest specifications, see our website: [www.triquint.com](http://www.triquint.com)  
Revision F, August 10, 2006



**3V GaAs HBT CDMA / WCDMA Cellular Power Amplifier Module**

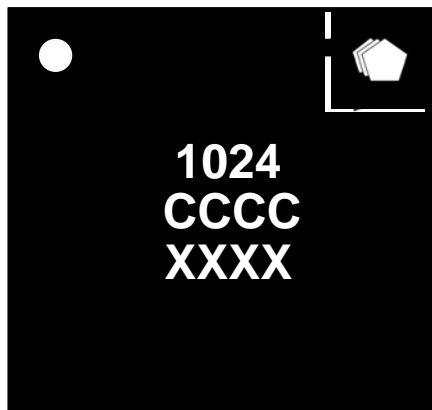

**WHITE INK OR LASER MARK**  
 Line 1: 1024 = (Product Code)  
 Line 2: CCCC = Country Code  
 (Example: Philippines = PHIL)  
 Line 3: XXXX = TriQuint Assembly Lot Number

Figure 4: Typical Case Markings (Top View)

Recommended PC board layout to Accept 8 Pin Module Package:

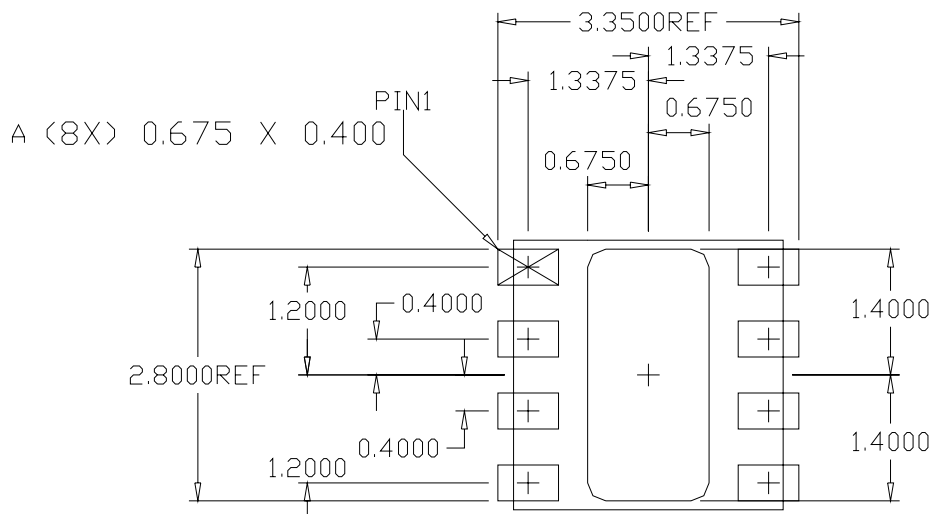

Figure 5: PCB Footprint Etch Recommendations (Top View)

Notes:

- 1.) Only ground signal traces are allowed directly under the package
- 2.) Primary dimensions are in millimeters alternate dimensions are in inches.

Data Sheet

For additional information and latest specifications, see our website: [www.triquint.com](http://www.triquint.com)  
 Revision F, August 10, 2006

**3V GaAs HBT CDMA / WCDMA Cellular Power Amplifier Module**

*Packaging and Ordering Information:*

Package Type: 8 Pin Plastic Module Package

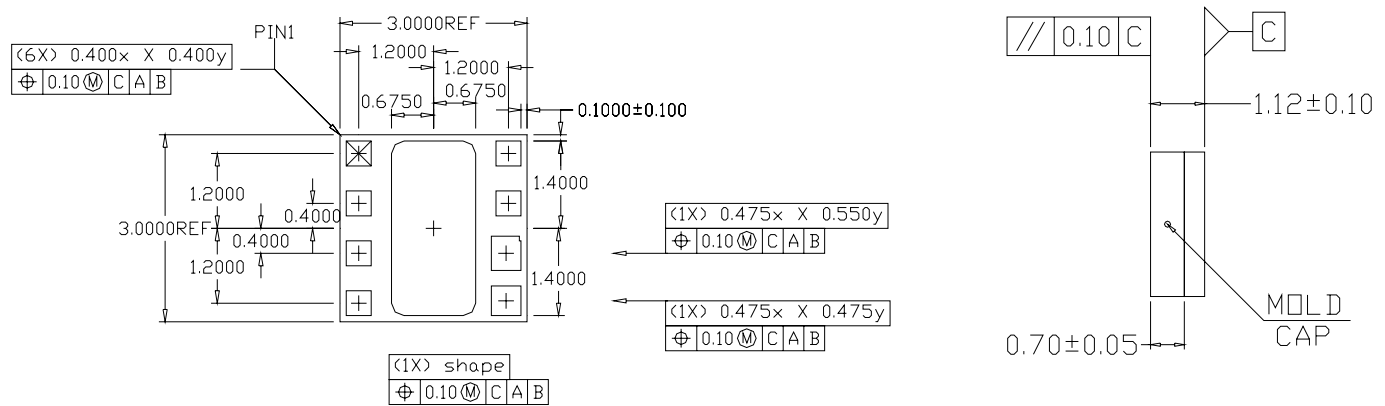

Figure 6: Package Drawing Information: Right (Top View) / Left (Side View)

Notes:

1.) GND solder mask openings are not centered on the package

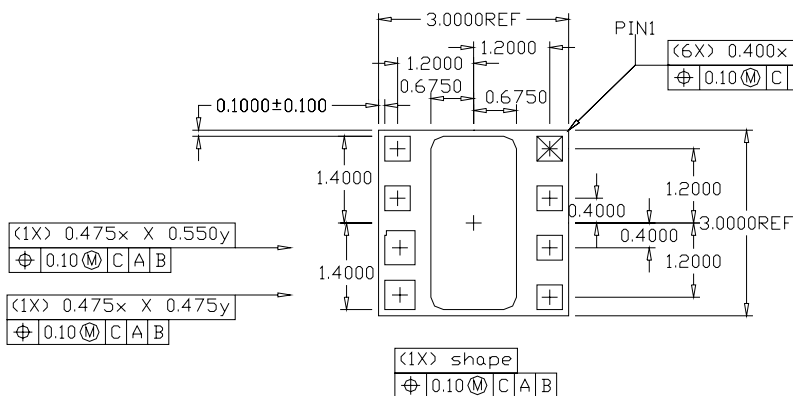

Figure 7: Package Drawing Information (Bottom View)

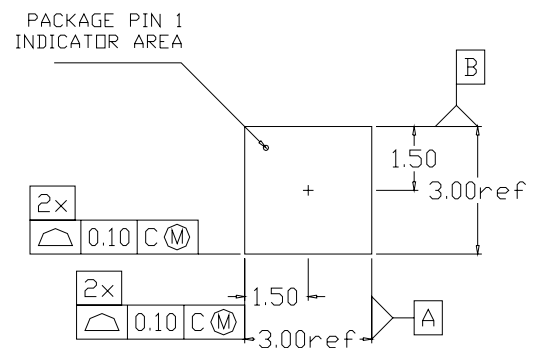

Figure 8: Package Marking Diagram

Data Sheet

For additional information and latest specifications, see our website: [www.triquint.com](http://www.triquint.com)  
Revision F, August 10, 2006

**3V GaAs HBT CDMA / WCDMA Cellular Power Amplifier Module**

*Tape and Reel Information:*

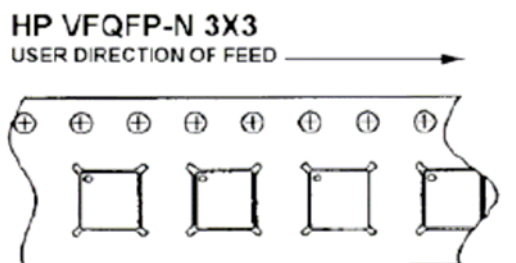

*Carrier Cover and Physical Tape Dimensions:*

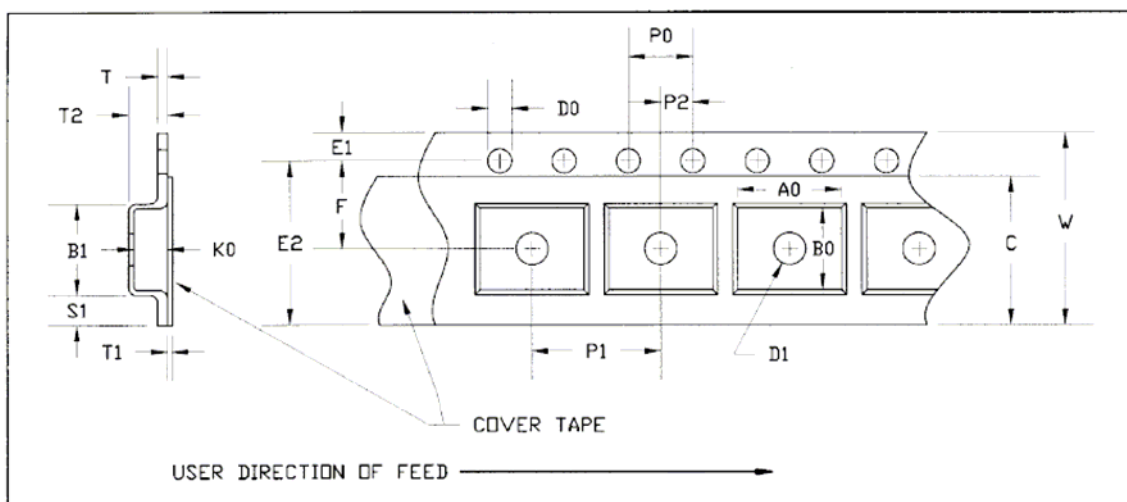

**HP VFQFP-N 3x3 8mm WIDE CARRIER AND COVER TAPE DIMENSIONS (See note 1)**

PART	FEATURE	SYMBOL	SIZE (in)	SIZE (mm)
CAVITY	LENGTH	A0	0.134	3.40
	WIDTH	B0	0.126	3.20
	DEPTH	K0	0.055	1.40
	PITCH	P1	0.157	4.00
DISTANCE BETWEEN CENTERLINE	CAVITY TO PERFORATION LENGTH DIRECTION	P2	0.079	2.00
	CAVITY TO PERFORATION WIDTH DIRECTION	F	0.138	3.50
COVER TAPE	WIDTH	C	0.213	5.40
CARRIER TAPE	WIDTH	W	0.315	8.00

*Data Sheet*

For additional information and latest specifications, see our website: [www.triquint.com](http://www.triquint.com)  
Revision F, August 10, 2006

**3V GaAs HBT CDMA / WCDMA Cellular Power Amplifier Module**

*Reel Physical Dimensions:*

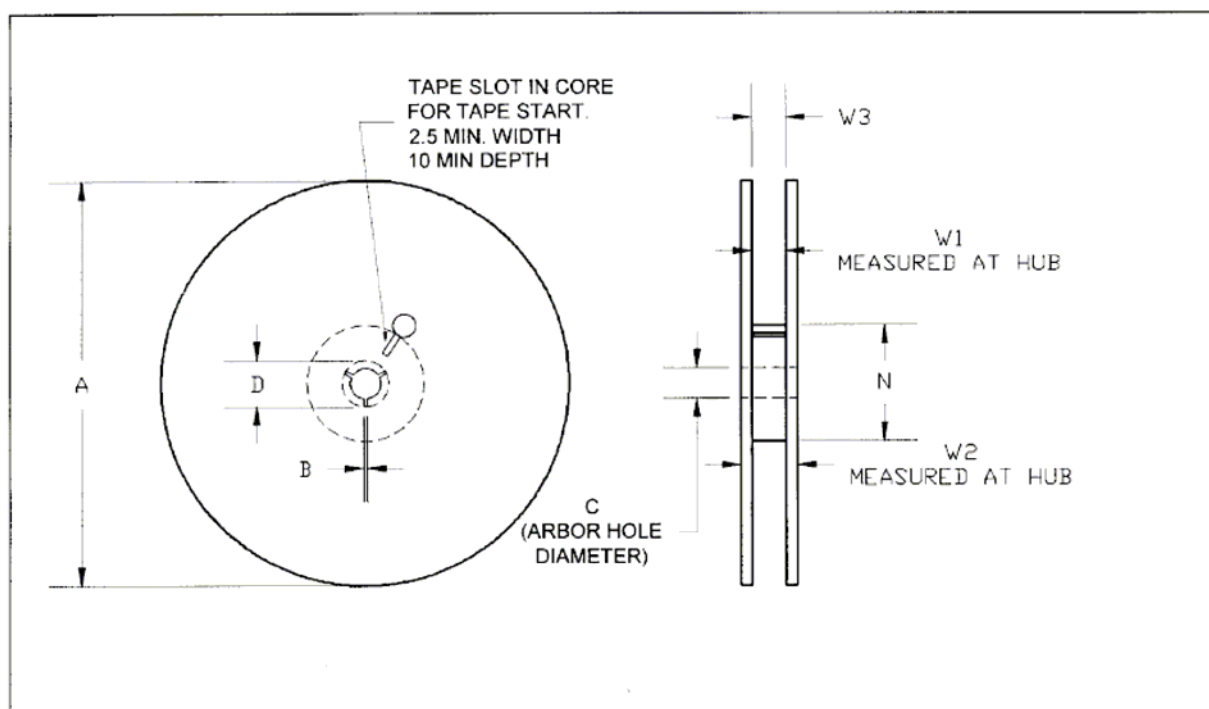

**Reel Dimensions for 8mm Carrier Tape**

SOT 23-6 & 8, HP VFQFP-N 2X2, 3X3, MW-6, SCT-598, SC 70-4 & 6, SLIM 7, 13 & 17, VQFN 6 3x2			7" Reel	
PART	FEATURE	SYMBOL	SIZE (in)	SIZE (mm)
FLANGE	DIAMETER	A	6.969	177.0
	THICKNESS	W2	0.559	14.2
	SPACE BETWEEN FLANGE	W1	0.346	8.8
HUB	OUTER DIAMETER	N	4.016	102.0
	ARBOR HOLE DIAMETER	C	0.512	13.0
	KEY SLIT WIDTH	B	0.079	2.0
	KEY SLIT DIAMETER	D	0.787	20.0

*Data Sheet*

For additional information and latest specifications, see our website: [www.triquint.com](http://www.triquint.com)  
Revision F, August 10, 2006

**3V GaAs HBT CDMA / WCDMA Cellular Power Amplifier Module**

*Tape Length and Label Placement:*

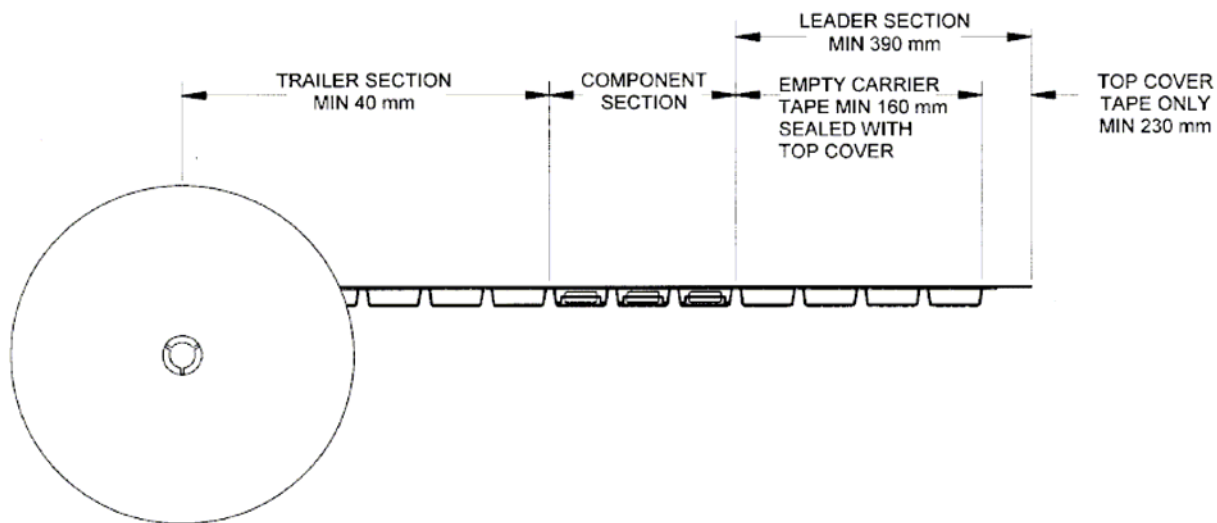

*Label Placement:*

Product label, Mfg Label and ESD label are placed on the flange opposite to the sprockets in the carrier tape

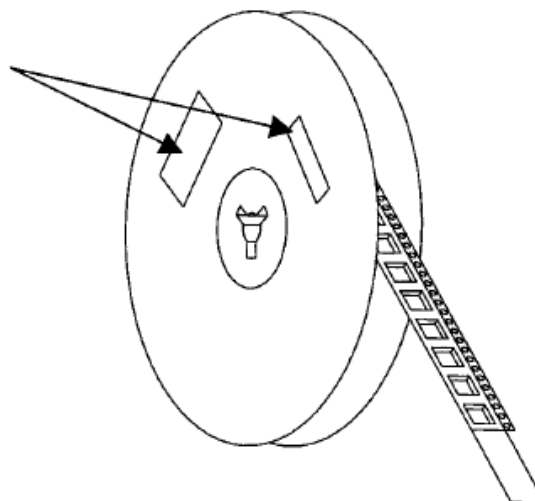

*Reel Quantity: 2,500 units*

*Data Sheet*

For additional information and latest specifications, see our website: [www.triquint.com](http://www.triquint.com)  
Revision F, August 10, 2006

**3V GaAs HBT CDMA / WCDMA Cellular Power Amplifier Module**

**Additional Information**<sup>1</sup>T

This part is compliant with RoHS directive (Restrictions on the Use of Certain Hazardous Substances in Electrical and Electronic Equipment).

The part is rated Moisture Sensitivity Level 3 at 260°C per JEDEC standard IPC/JEDEC J-STD-020.

---

<sup>1</sup> For latest specifications, additional product information, worldwide sales and distribution locations, and information about TriQuint:

Web: [www.triquint.com](http://www.triquint.com)

Tel: (503) 615-9000

Email: [info\\_wireless@tqs.com](mailto:info_wireless@tqs.com)

Fax: (503) 615-8902

For technical questions and additional information on specific applications:

Email: [info\\_wireless@tqs.com](mailto:info_wireless@tqs.com)

The information provided herein is believed to be reliable; TriQuint assumes no liability for inaccuracies or omissions. TriQuint assumes no responsibility for the use of this information, and all such information shall be entirely at the user's own risk. Prices and specifications are subject to change without notice. No patent rights or licenses to any of the circuits described herein are implied or granted to any third party.

TriQuint does not authorize or warrant any TriQuint product for use in life-support devices and/or systems.

Copyright © 2006 TriQuint Semiconductor, Inc. All rights reserved.