



Details are subject to change without notice

400-mA MULTI-INPUT LOW-DROPOUT REGULATOR WITH DUAL OUTPUT POWER MANAGEMENT

Features

- Complete Power Management
- Automatic Input Voltage Selection
- Input Voltage Source Detector With Hysteresis
- 400-mA Load Current Capability With VCC50、 VSB50 or AUX33 Input Source
- Integrated Low $r_{DS(on)}$ Switch
- Dual Regulated Output 3.3V (fixed) & 2.5V (fixed)
- Output Short Circuit Protection (SCP)

Pin Configuration

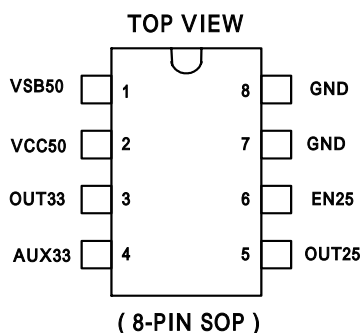

Description

The AAT1205 is a multi-input low-dropout regulator (LDO) specially designed for LAN cards. It provides advanced dual constant output supply 3.3V & 2.5V at the output capable of driving a 400-mA load. The output (OUT25) can be disabled by connecting EN25 pin to GND.

The AAT1205 is equipped with dual regulated power output for systems with multiple input sources and require dual constant voltage source with a low-dropout voltage. This is an intelligent power source selection device with a low-dropout regulator for either VCC50 or VSB50 inputs, and a low-resistance bypass switch for the AUX33 input.

The AAT1205 allows transitions to progress smoothly from one input supply to another without generating a glitch outside of the specified range of 3.3V & 2.5V output. Furthermore, this device has an incorporated reverse-blocking scheme to prevent excessive leakage from the input terminals in the event that the output voltage is greater than the input voltage.

The input voltage is prioritized in the following order: VCC50, VSB50, AUX33.

**Function Table**

INPUT VOLTAGE STATUS (V)				INPUT SELECTED	OUTPUT (V)		OUTPUT (I) (mA)
EN25	VCC50	VS50	AUX33	VCC50/VS50/AUX33	OUT33	OUT25	Iout33+Iout25
Hi	0	0	0	None	0	0	0
Low	0	0	0	None	0	0	0
Hi	0	0	3.3	AUX33	3.3	2.5	400
Low	0	0	3.3	AUX33	3.3	0	400
Hi	0	5	0	VS50	3.3	2.5	400
Low	0	5	0	VS50	3.3	0	400
Hi	0	5	3.3	VS50	3.3	2.5	400
Low	0	5	3.3	VS50	3.3	0	400
Hi	5	0	0	VCC50	3.3	2.5	400
Low	5	0	0	VCC50	3.3	0	400
Hi	5	0	3.3	VCC50	3.3	2.5	400
Low	5	0	3.3	VCC50	3.3	0	400
Hi	5	5	0	VCC50	3.3	2.5	400
Low	5	5	0	VCC50	3.3	0	400
Hi	5	5	3.3	VCC50	3.3	2.5	400
Low	5	5	3.3	VCC50	3.3	0	400

Pin Description

TERMINAL NAME	NO.	I/O	Description
VS50	1	I	5V Standby Supply Input
VCC50	2	I	5V Main Supply Input
OUT33	3	O	3.3V Regulated Output
AUX33	4	I	3.3V Auxiliary Supply Input
OUT25	5	O	2.5V Regulated Output
EN25	6	I	Enable Input of OUT25
GND	7	I	Ground
GND	8	I	Ground



Absolute Maximum Ratings[†]

- Main Supply Voltage, $V_{(VCC50)}$ -0.5V~7V
- Standby Supply Voltage, $V_{(VSB50)}$ -0.5V~7V
- Auxiliary Supply Voltage, $V_{(AUX33)}$ -0.5V~7V
- Output Current Limit, $I_{(LIMIT)}$ 1.5A
- Continuous Power Dissipation, P_d (see Note 1) 1.6W
- Electrostatic Discharge Susceptibility, Human Body Mode 2kV
- Operating Ambient Temperature Range, T_C 0 to 70
- Storage Temperature Range, $T_{storage}$ -45 to +125
- Operating Junction Temperature Range, T_J -5 to +130
- Lead Temperature (Soldering for 10 seconds), $T_{(LEAD)}$ 260

Note 1 : The device deteriorates with increase in ambient temperature, T_C . See Thermal Information section.

Recommended Operating Conditions

Parameter	Min	Typ	Max	Unit
5V Main Supply Input, VCC50	4.5	-	5.5	V
5V Standby Supply Input, VSB50	4.5	-	5.5	V
3.3V Auxiliary Supply Input, AUX33	3.0	-	3.6	V
Load Capacitance, C_L	4.23	4.70	5.17	μ F
Load Current, I_L	0	-	400	mA
Ambient Temperature, T_C	0	-	70	



**Electrical Characteristics Over Recommended Operating Free-Air Temperature,
 $T_C = 0$ to 70 , $C_L = 4.7\mu\text{F}$ (unless otherwise specified)**

Parameter	Symbol	Test Condition	Min	Typ	Max	Unit
5V Inputs	VCC50 VSB50		4.5	5.0	5.5	V
3.3V Output	OUT33	$I_{\text{out}33} + I_{\text{out}25} = 400\text{mA}$	3.135	3.300	3.465	V
2.5V Output	OUT25	$I_{\text{out}33} = 0$, $I_{\text{out}25} = 300\text{mA}$	2.375	2.500	2.625	V
Line Regulation Voltage	$\Delta V_{O(\Delta V)}$	VSB50 or VCC50 = 4.5V to 5.5V	-	2	-	mV
Load Regulation Voltage	$\Delta V_{O(\Delta I)}$	$20\text{ mA} < I_L < 250\text{ mA}$	-	40	-	mV
Quiescent Supply Current	I_{50}	From VCC50 VSB50 terminals, $I_L = 0$ to 400mA	-	1.0	3.0	mA
I_{AUX}	I_{AUX}	From AUX33 terminal, $I_L = 0\text{A}$	-	1.0	3.0	mA
Out33 Load Current	I_{L33}		0.4	-	-	A
Out25 Load Current	I_{L25}		0.3	-	-	
Output Current Limit	I_{LIMIT}	Out33 or Out25 output shorted to 0V	-	-	1.5	
Thermal Shutdown (Note 2)	T_{TSD}		150	-	180	
Thermal Hysteresis (Note 2)	T_{hys}		-	15	-	
Load Capacitance	C_L	Minimal ESR to insure stability of regulated output	-	4.7	-	μF
Reverse Leakage Output Current	$I_{\text{Ikg}(\text{REV})}$	Tested for input that is grounded. AUX33, VSB50 or VCC50 = GND, Out33 = 3.3V	-	-	50	μA
Threshold Voltage, Low	V_{LO}	VSB50 or VCC50↓	4.0	4.2	4.4	V
Threshold Voltage, High	V_{HI}	VSB50 or VCC50↑	4.25	4.45	4.65	V
Auxiliary Switch Resistance	R_{SWITCH}	VSB50 = VCC50 = 0V, AUX33 = 3.3V, $I_L = 150\text{mA}$	-	-	0.4	Ω
	R_{OJA}	Power Pad is not soldered on the heat spreading copper	-	80	-	/
		Power Pad is soldered on the heat spreading copper	-	50	-	W

Note 2 : Design targets only. Not tested in production.

Note 3 : Please refer to "Thermal Information"



Typical Characteristics

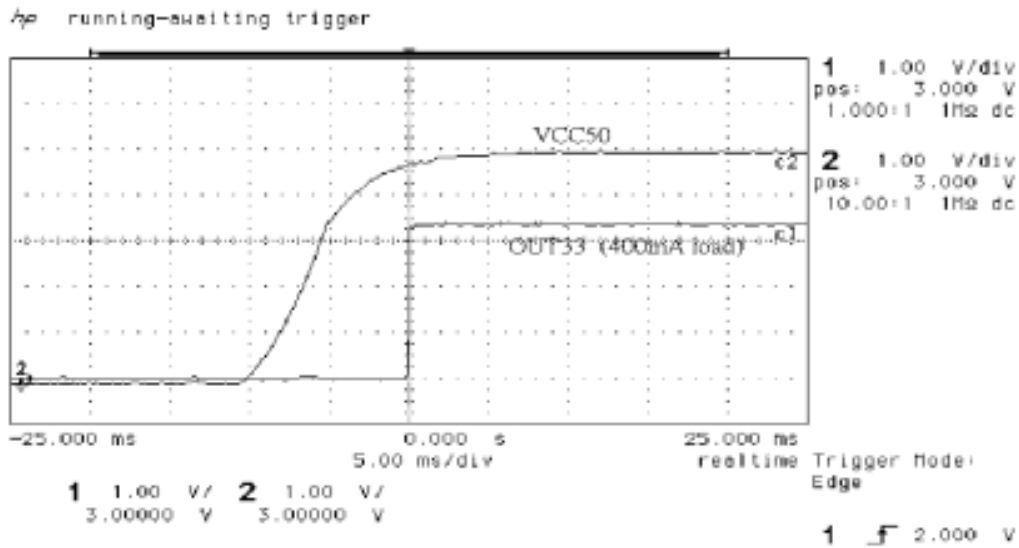

Fig. 1. 3.3V VCC50 Cold Start

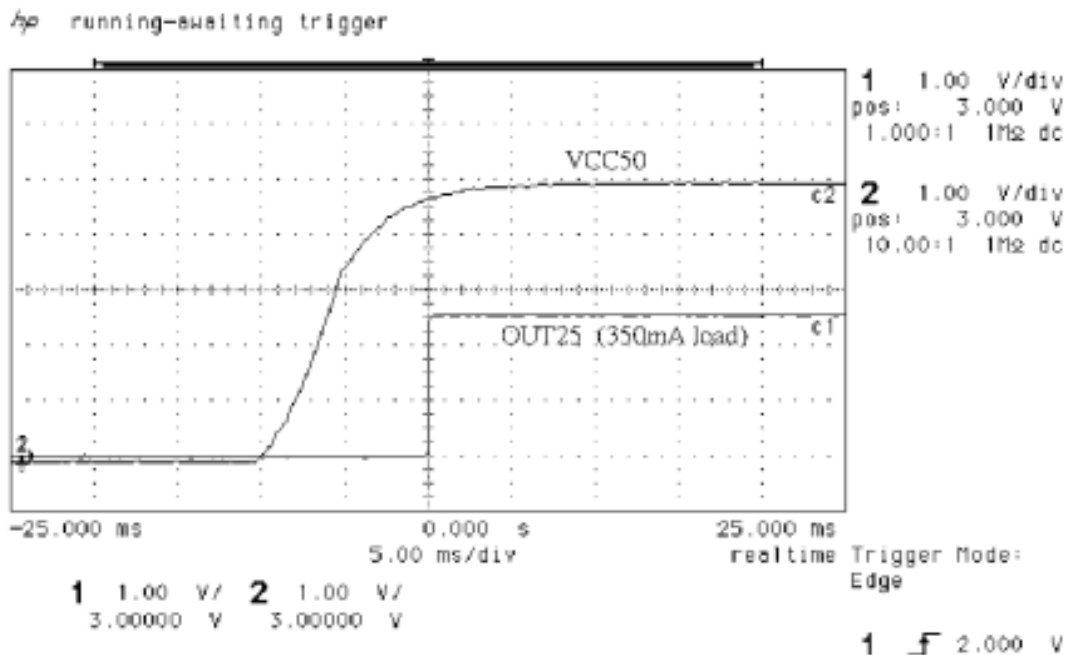

Fig. 2. 2.5V VCC50 Cold Start

– 台灣類比科技股份有限公司 –
– Advanced Analog Technology, Inc. –



Typical Characteristics

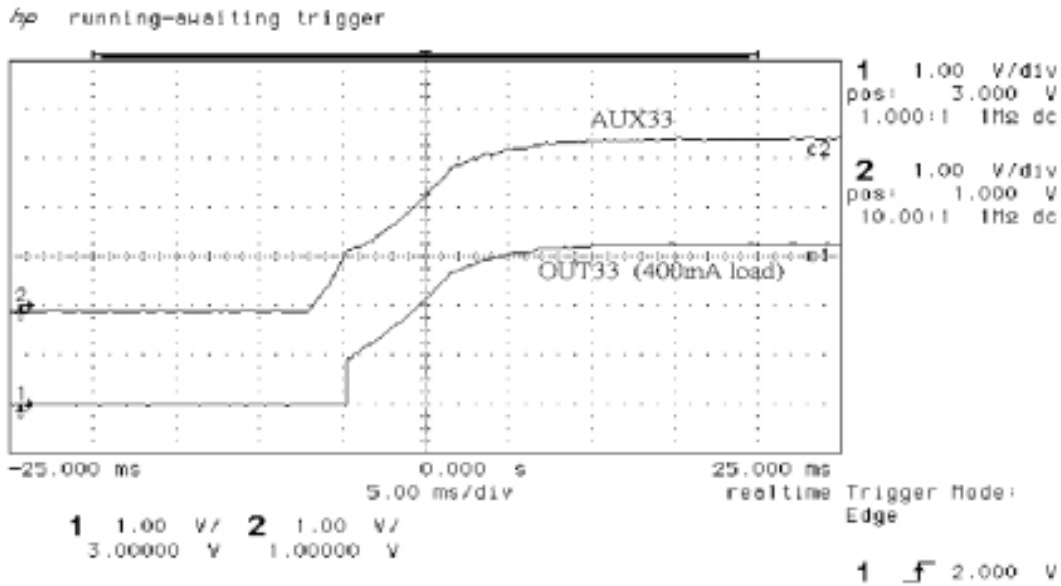

Fig. 3. 3.3V AUX33 Cold Start

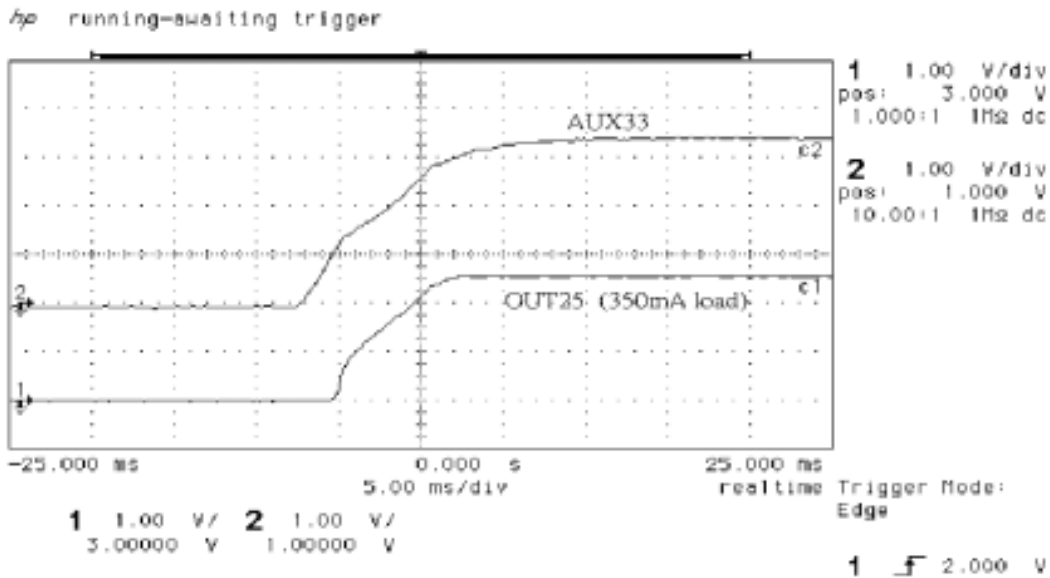

Fig. 4. 2.5V AUX33 Cold Start



Typical Characteristics

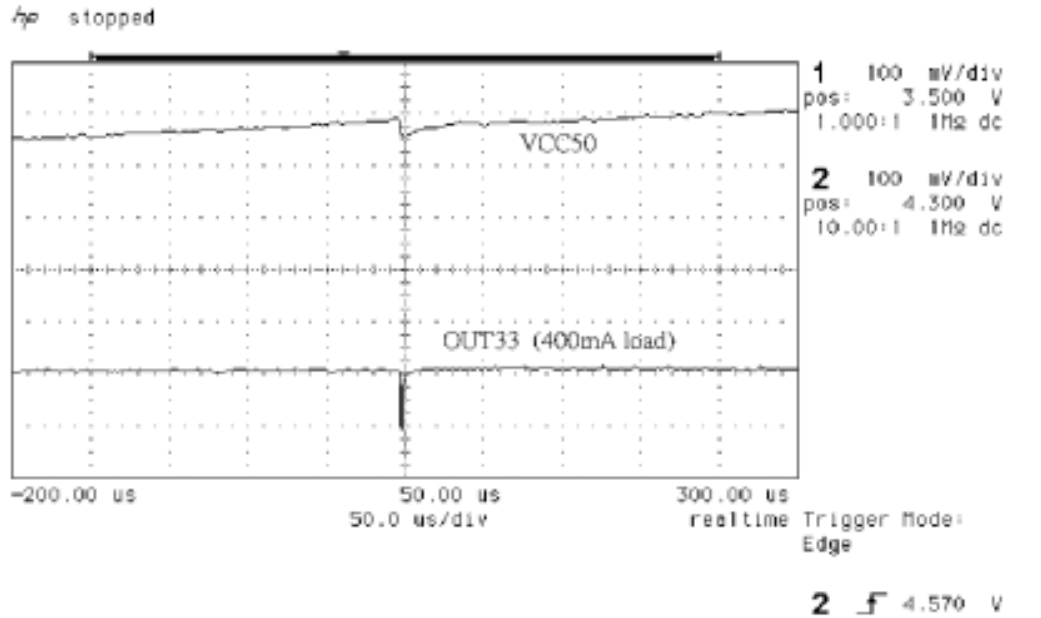

Fig. 5. 3.3V VCC50 Power Up (VSB50=5V)

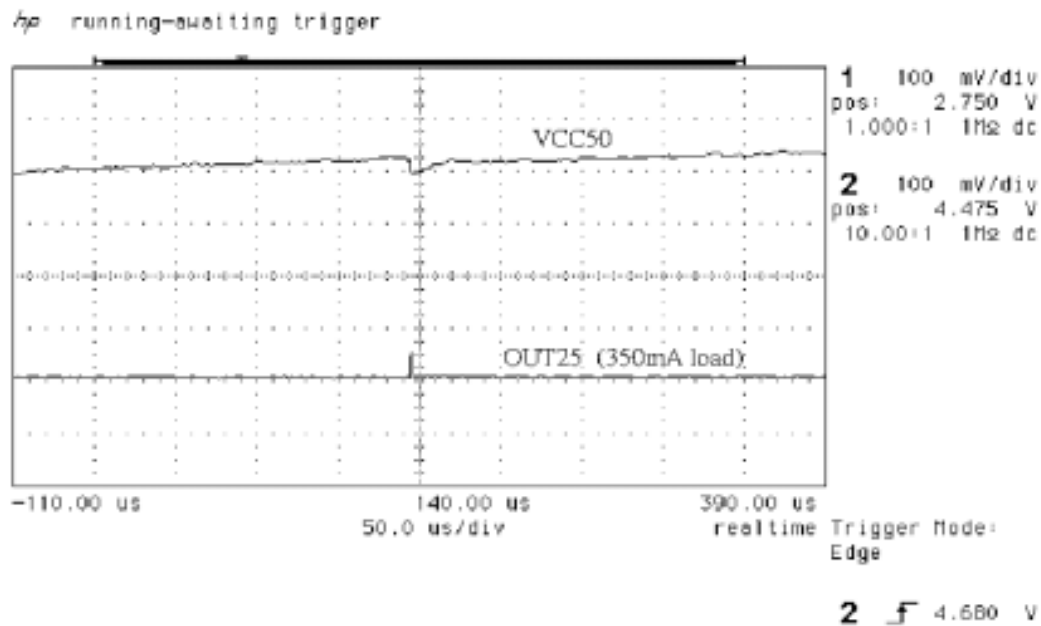

Fig. 6. 2.5V VCC50 Power Up (VSB50=5V)



Typical Characteristics

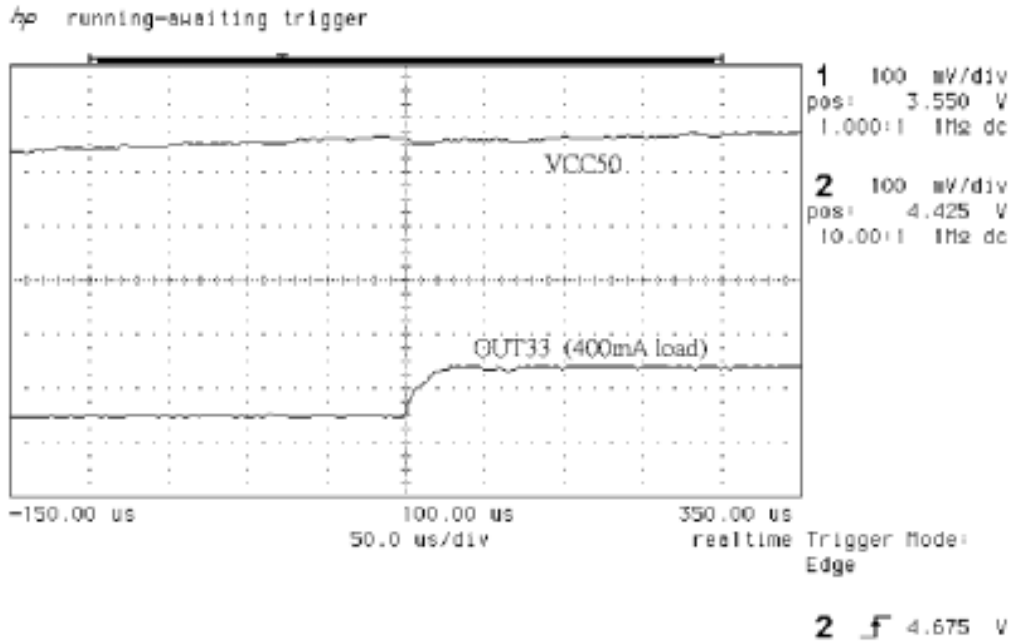

Fig. 7. 3.3V VCC50 Power Up (AUX33=3.3V)

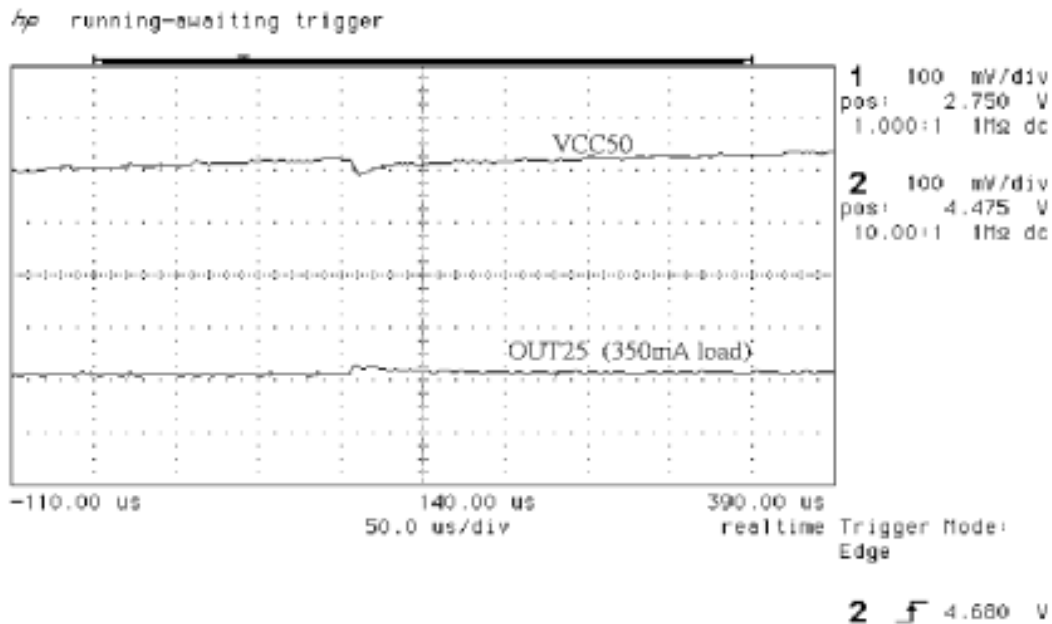

Fig. 8. 2.5V VCC50 Power Up (AUX33=3.3V)



Typical Characteristics

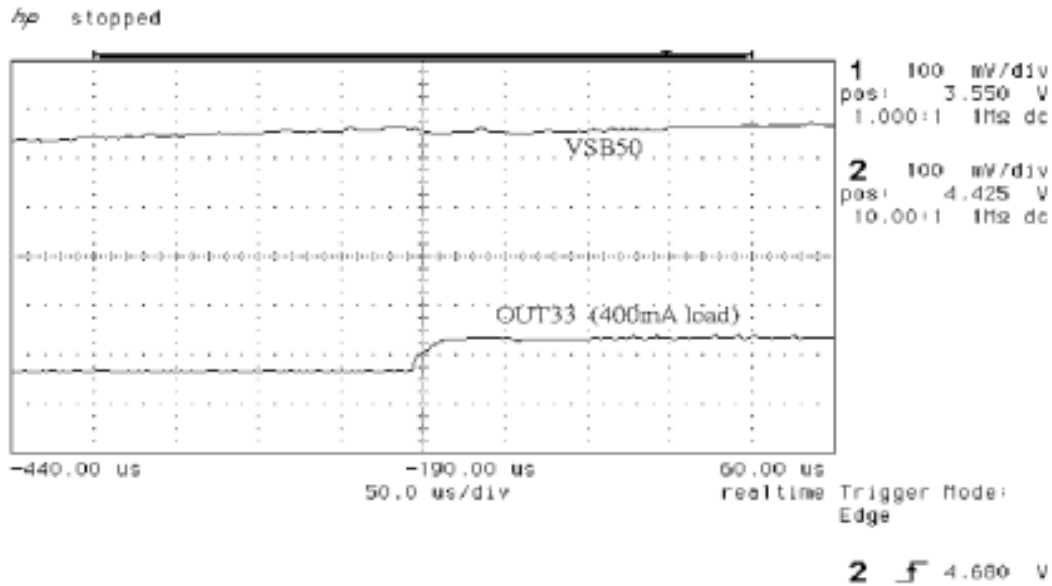

Fig. 9. 3.3V VSB50 Power Up (AUX33=3.3V)

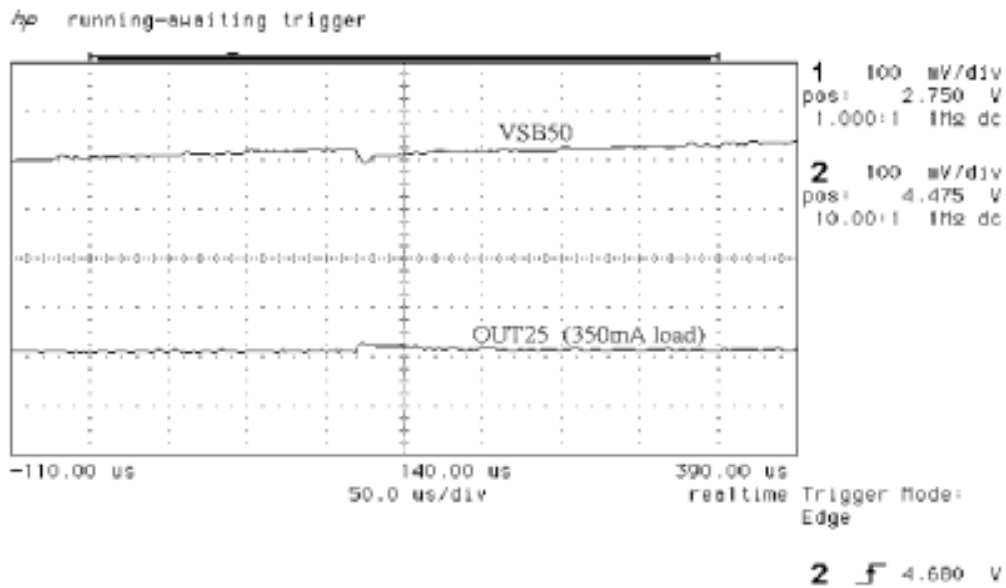

Fig. 10. 2.5V VSB50 Power Up (AUX33=3.3V)



Typical Characteristics

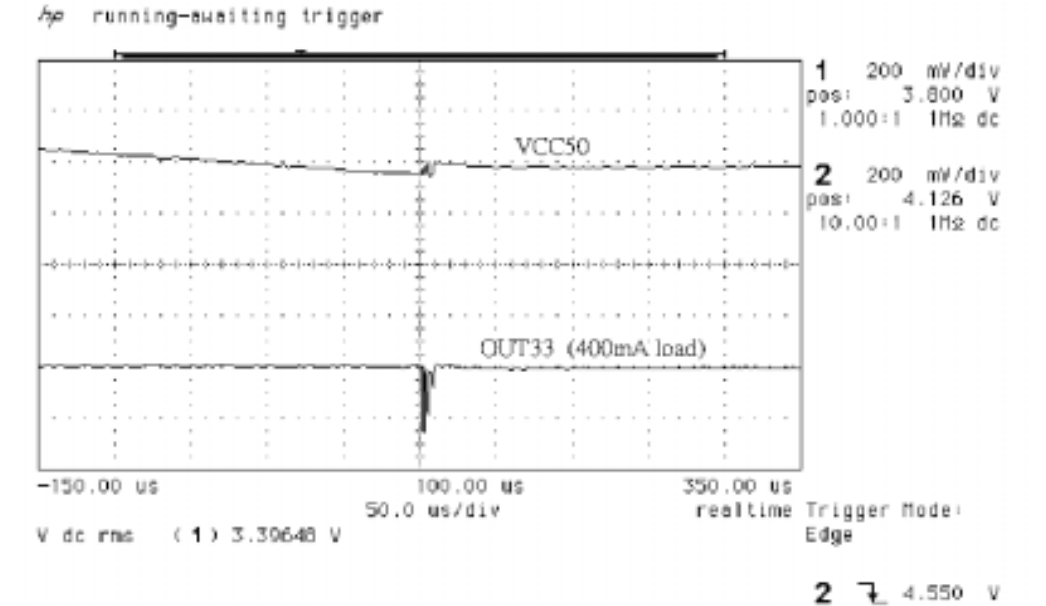

Fig.11. 3.3V VCC50 Power Down (VSB=5V)

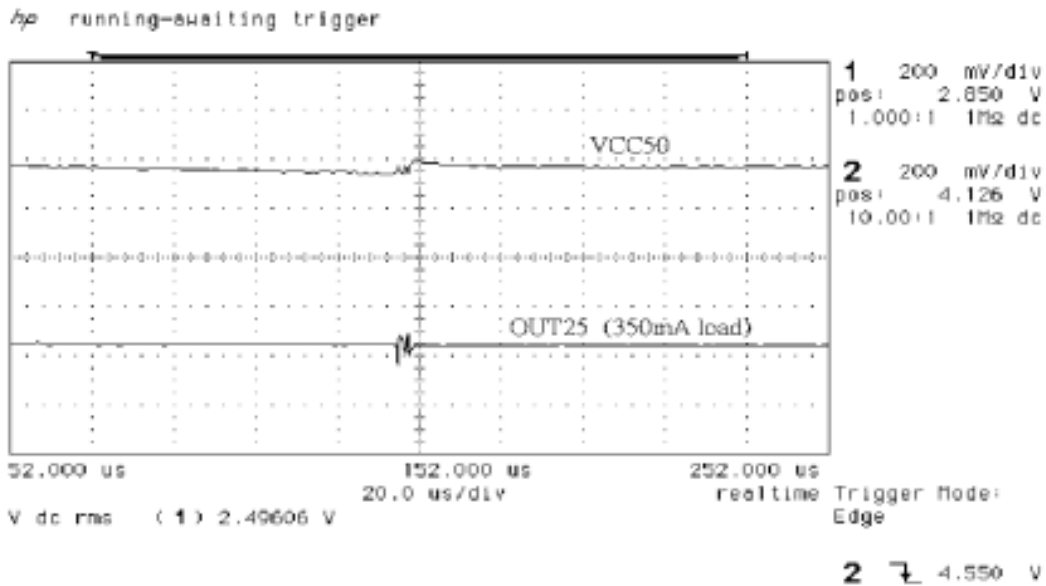

Fig. 12. 2.5V VCC50 Power Down (VSB=5V)



Typical Characteristics

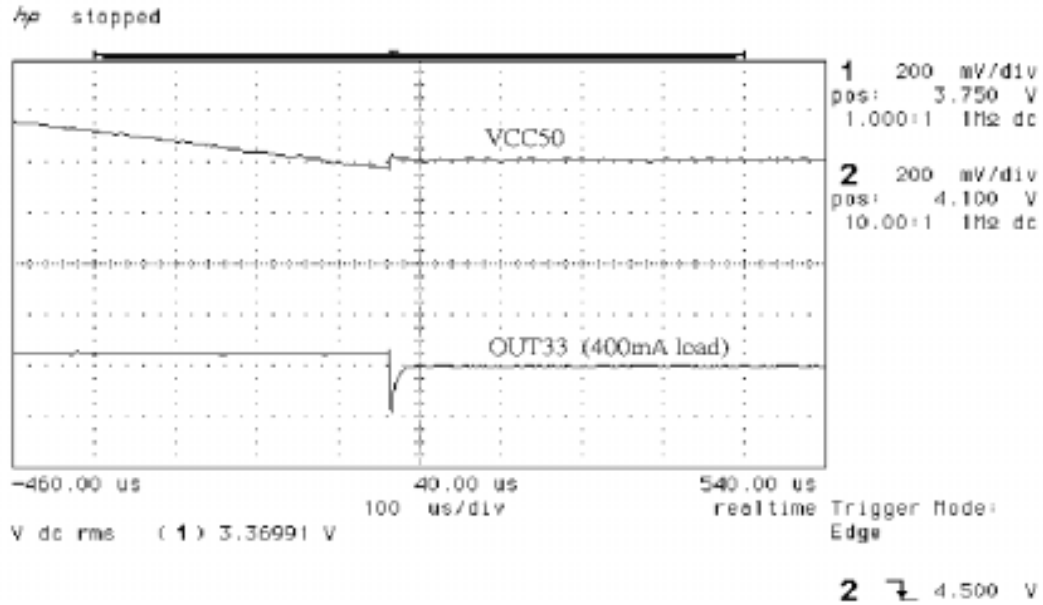

Fig. 13. 3.3V VCC50 Power Down (AUX33=3.3V)

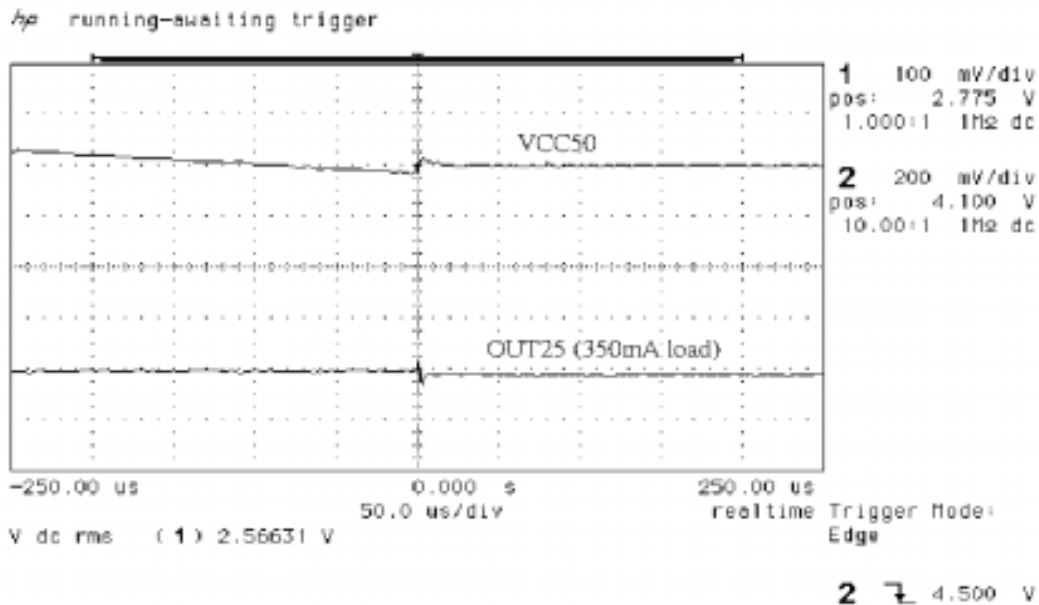

Fig. 14. 2.5V VCC50 Power Down (AUX33=3.3V)



Typical Characteristics

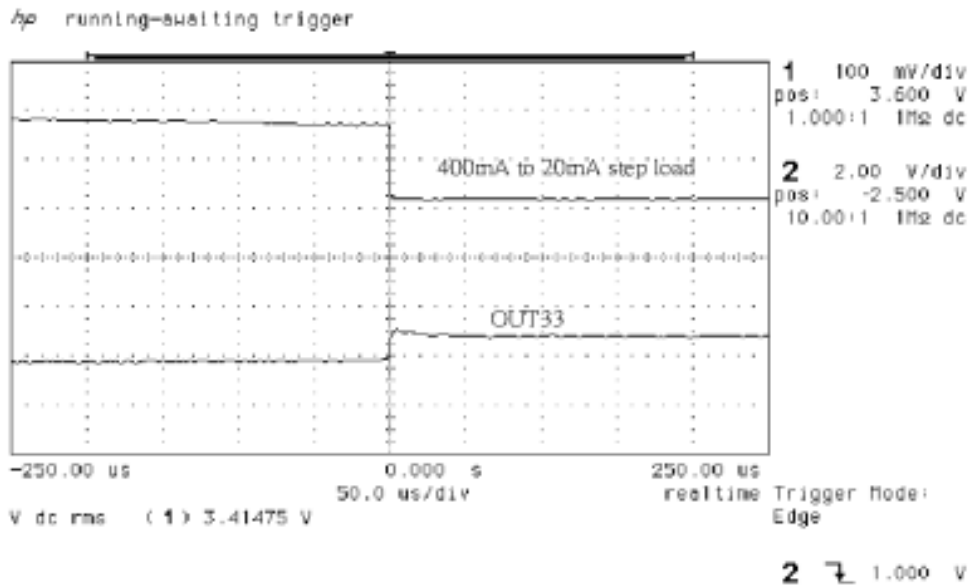

Fig. 15. 3.3V Load Transient Response Falling

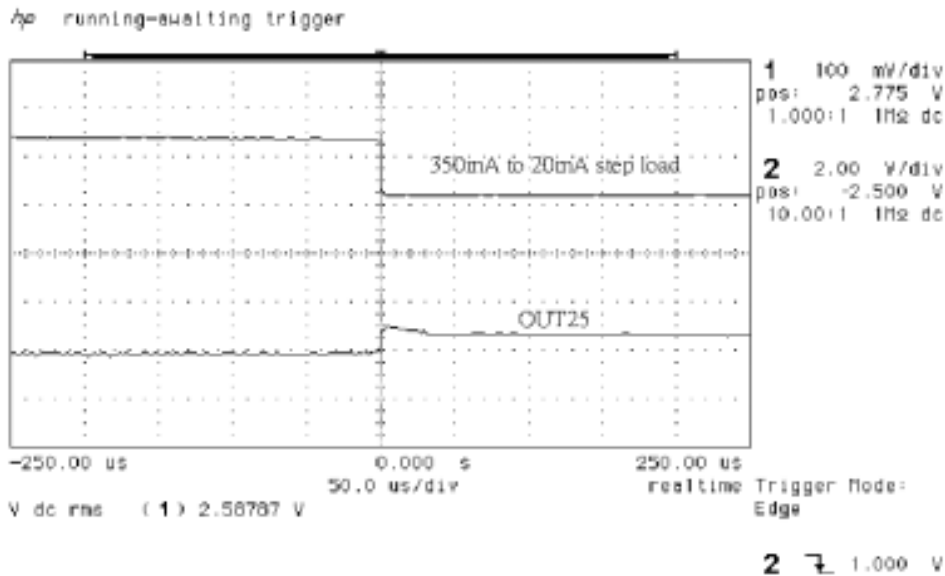

Fig. 16. 2.5V Load Transient Response Falling



Typical Characteristics

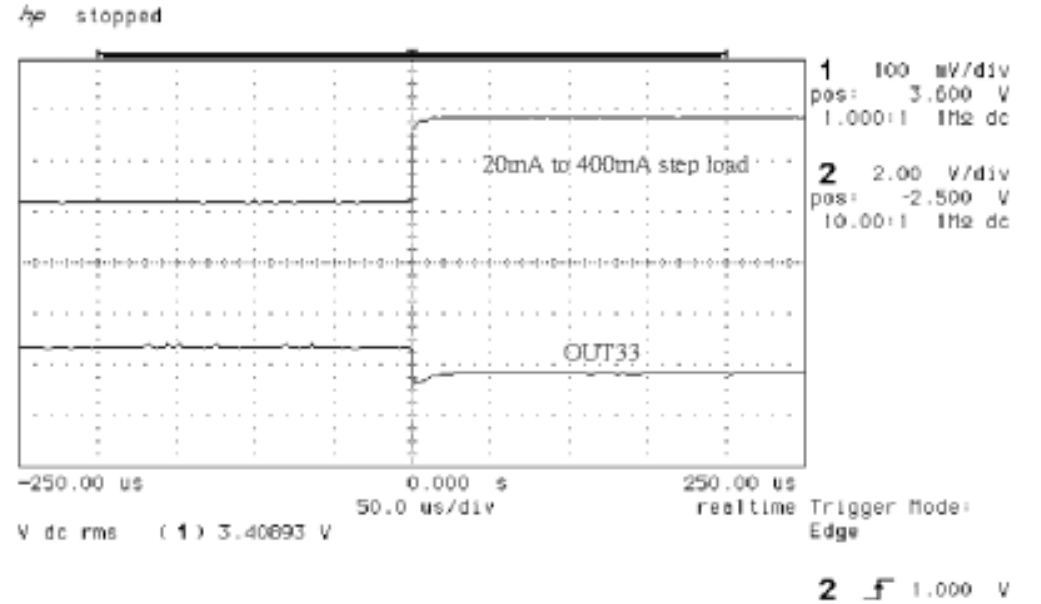

Fig. 17. 3.3V Load Transient Response Rising

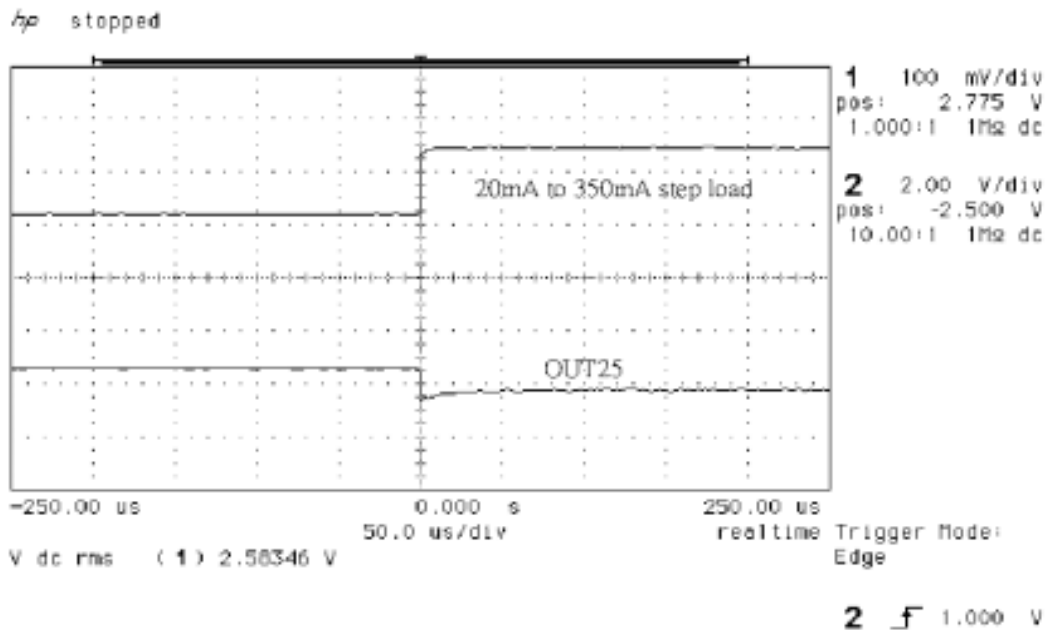

Fig. 18. 2.5V Load Transient Response Rising



Thermal Information

To ensure reliable operation of the device, the junction temperature of the output device must be within the safe operating area (SOA). This is achieved by having a means to dissipate the heat generated from the junction of the output structure. There are two components that contribute to thermal resistance. They consist of two paths in series. The first path is the junction to case thermal resistance, R_{JC} ; the second path is the case to ambient thermal resistance, R_{CA} . The overall junction to ambient thermal resistance, R_{JA} , is determined by :

$$R_{JA} = R_{JC} + R_{CA}$$

Package and board layout incorporated in the application determines the ability to efficiently dissipate the heat from the junction. The operating junction temperature is determined by the operation ambient temperature, T_C , and the junction power dissipation, P_J .

The junction temperature, T_J , is equal to the following thermal equation :

$$T_J = T_C + P_J (R_{JC}) + P_J (R_{CA})$$
$$T_J = T_C + P_J (R_{JA})$$

The AAT1205 is housed in a thermal enhanced package where the power pad is located in the bottom of the device. When the power pad is soldered on a double-sided printed circuit board with two square inches of copper allocated for "heat spreading", the resulting θ_{JA} is 50 °C/W. Hence, the maximum power dissipation allowable for an operating ambient temperature of 70 °C, and a maximum junction temperature of 150 °C is determined as :

$$P_J = (T_J - T_C) / R_{JA}$$
$$P_J = (150 - 70) / 50 = 1.6W$$

Worst case maximum power dissipation is determined by :

$$P_d = (5.5 - 2.375) \times 0.3 + (5.5 - 3.135) \times 0.1 = 0.9375 + 0.2365 = 1.174W$$

Normal operating maximum power dissipation is :

$$P_d = (5 - 2.5) \times 0.3 + (5 - 3.3) \times 0.1 = 0.75 + 0.17 = 0.92W$$

Note: All thermal characteristics of the AAT1205 were measured using a double-sided board with two square inches of copper area connected to the GND pins for "heat spreading". The use of multi-layer board construction with power planes will further enhance the thermal performance of the package.



Thermal Information (Cont.)

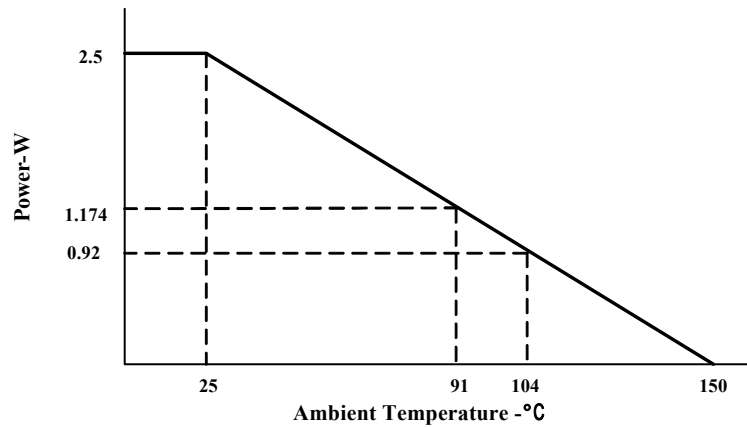

Note: These curves are to be used for guideline purposes only. For a particular application, a more specific thermal characterization is required.

Power Dissipation Derating Curves

PCB Layout Example





Application Information

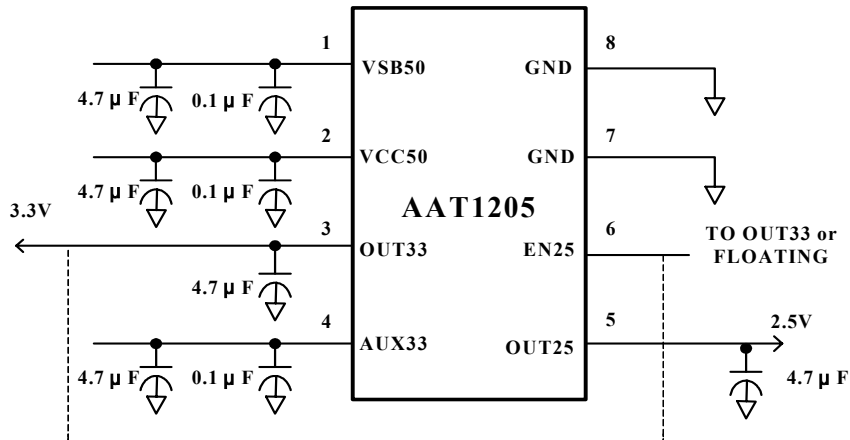

Typical Application Schematic - Dual Output

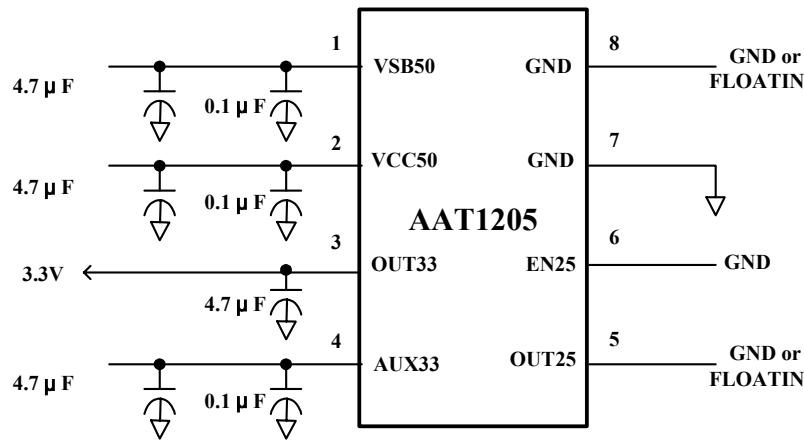

Typical Application Schematic - Only OUT33 Used



Package Dimension

8-PIN SOP

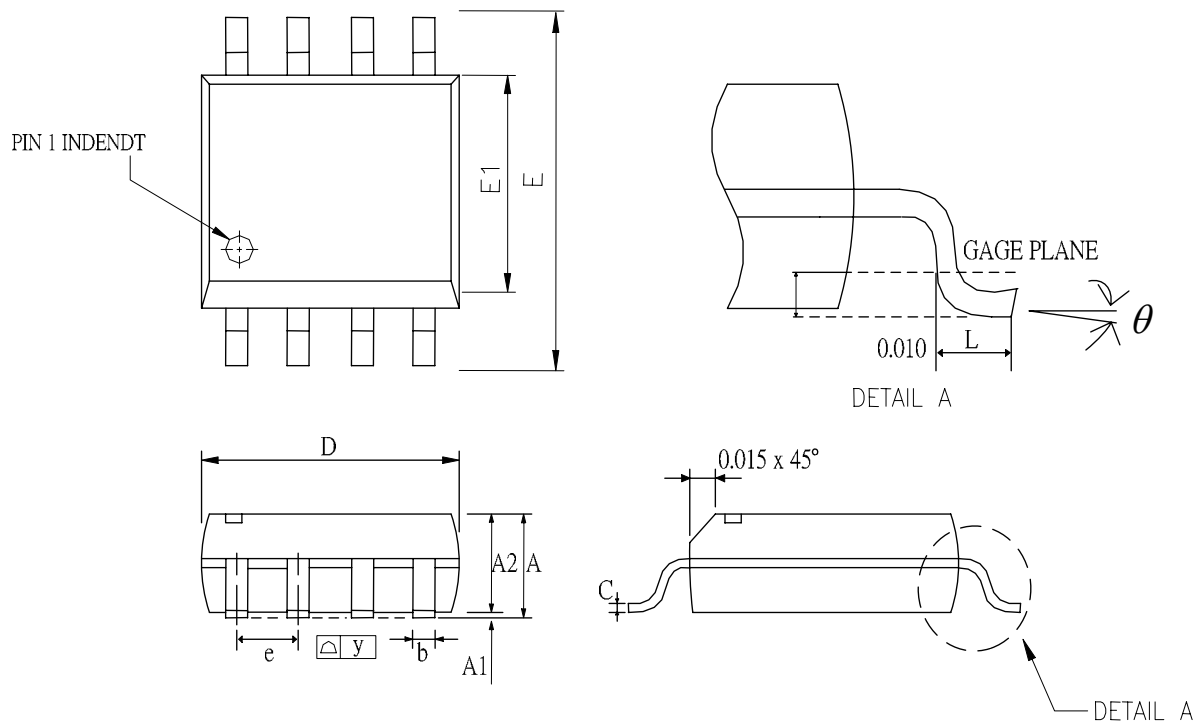

SYMBOL	DIMENSIONS IN			DEMINSIONS IN		
	MIN	TYP	MAX	MIN	TYP	MAX
A	1.47	1.60	1.73	0.058	0.063	0.068
A1	0.10	---	0.22	0.004	---	0.008
A2	---	1.45	---	---	0.057	---
b	0.33	0.41	0.51	0.013	0.016	0.020
C	0.19	0.20	0.25	0.0075	0.008	0.0098
D	4.80	4.85	4.95	0.189	0.191	0.195
E	5.80	6.00	6.20	0.228	0.236	0.244
E1	3.80	3.90	4.00	0.150	0.154	0.157
e	---	1.27	---	---	0.050	---
L	0.38	0.71	1.27	0.015	0.028	0.050
y	---	---	0.076	---	---	0
theta	0	---	0	0	---	0



Tape and Reel
8-Pin SOP

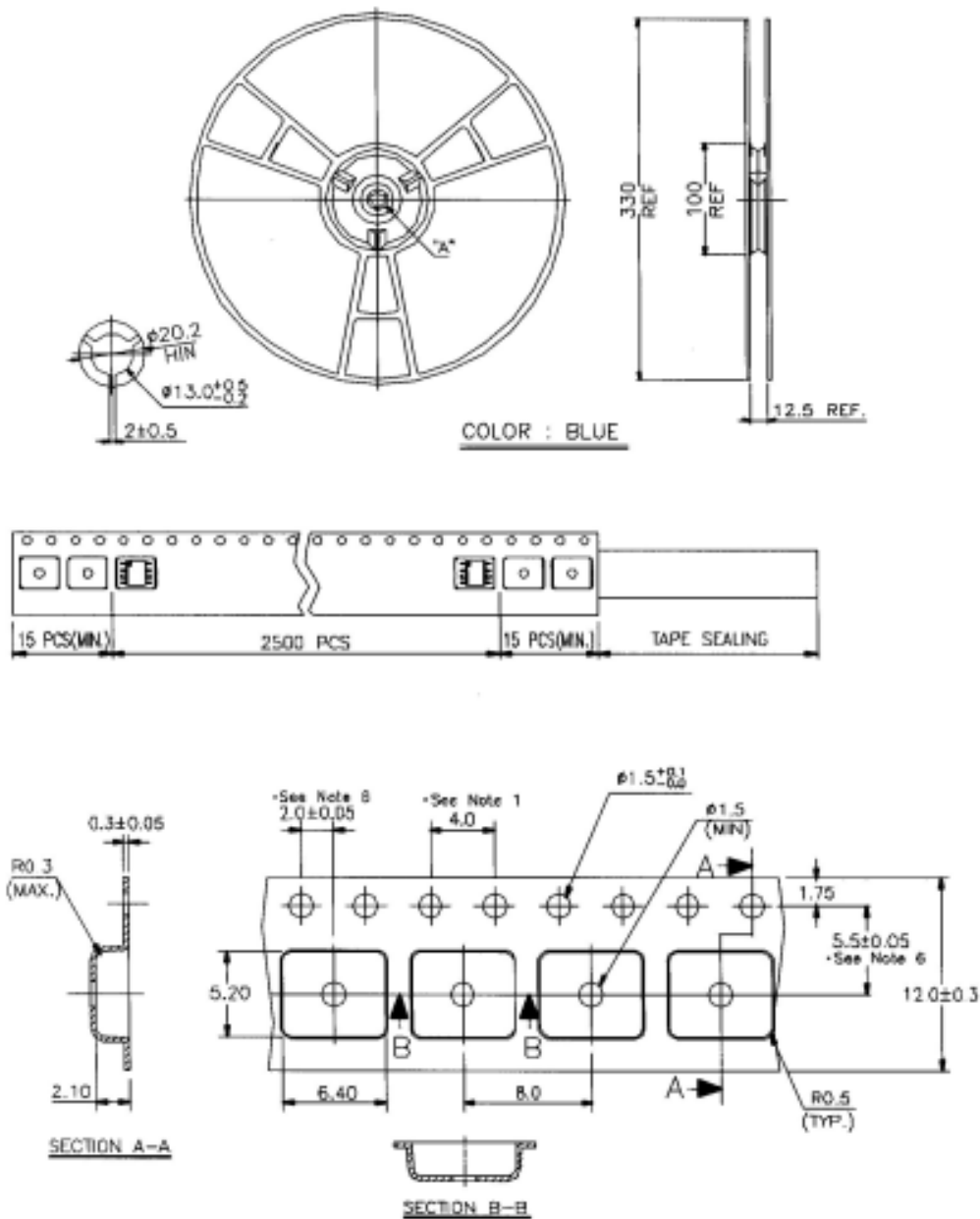

– 台灣類比科技股份有限公司 –
– Advanced Analog Technology, Inc. –



Tape and Reel

8-Pin SOP (Cont.)

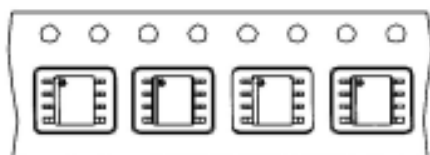

SOP 8N(150mil)

NOTE:

1. 10 SPROCKET HOLE PITCH CUMULATIVE TOLERANCE ± 0.2 MILLIMETERS.
2. CAMBER NOT TO EXCEED 1 MILLIMETER IN 100 MILLIMETERS
3. MATERIAL: ANTI-STATIC BLACK ADVANTEK POLYSTYRENE.
4. A_0 AND B_0 ARE MEASURED ON A PLANE 0.3 MILLIMETERS ABOVE THE BOTTOM OF THE POCKET.
5. K_0 IS MEASURED FROM A PLANE ON THE INSIDE BOTTOM OF THE POCKET TO THE TOP SURFACE OF THE CARRIER.
6. POCKET POSITION RELATIVE TO SPROCKET HOLE IS MEASURED AS TRUE POSITION OF POCKET, NOT POCKET HOLE.

Part Marking

SOP8 Top Marking

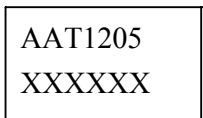

SOP8 Back Marking

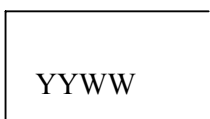



Ordering Information

