



Details are subject to change without notice.

ONE-CHANNEL STEP-UP PWM CONTROLLER

FEATURES

- Under-Voltage Lockout (UVLO) Protection
- Totem Pole Output
- Output Short Circuit Protection
- Soft-Start Function
- Wide Operating Frequency :
10 kHz to 1MHz
- Shutdown Control
- Low Dissipation Current :
Typical 1.6mA in Operation
- SOP-8 & TSSOP-8 Package Available

GENERAL DESCRIPTION

The AAT1109 is a one-channel step-up PWM controller incorporating a soft-start and a short circuit protection (SCP) function.

This device consists of an on-chip voltage reference, error amplifier, pulse width modulation controller, under-voltage lockout protection, soft-start, and short circuit protection circuits. Switching frequency up to 1MHz is set by an external resistor and capacitor. Soft-start time can be implemented by the SCP capacitor.

Additionally, a chip-enable feature is also provided to power down and reduce the current supply to 10 μ A. With the minimal external components, the AAT1109 offers a simple and economical solution.

PIN CONFIGURATION

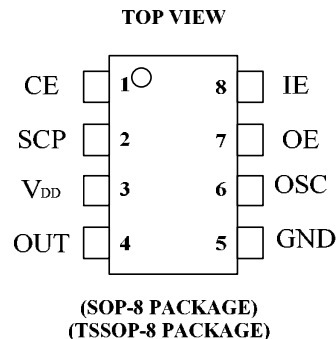

**PIN DESCRIPTION**

PIN NO.	NAME	I/O	DESCRIPTION
1	CE	I	Chip Enable Input Pin (Internal Pull "H")
2	SCP	I	Soft-Start and SCP Capacitor Connection Pin
3	V _{DD}	-	Power Supply
4	OUT	O	Totem Pole Type Output Pin
5	GND	-	Ground
6	OSC	O	Capacitor and Resistor Connection Pin for Setting the Oscillation Frequency
7	OE	O	Output Pin of Error Amplifier
8	IE	I	Inverting Input Pin of Error Amplifier

ABSOLUTE MAXIMUM RATINGS

CHARACTERISTICS	SYMBOL	VALUE	UNIT
Supply Voltage	V _{DD}	7	V
Output Current	I _O	-120/+120	mA
Operating Free-Air Temperature Range	T _C	-20 to +85	°C
Storage Temperature Range	T _{storage}	-45 to +125	°C
Power Dissipation	P _d	500	mW

RECOMMENDED OPERATING CONDITIONS

	SYMBOL	MIN	MAX	UNIT
Supply Voltage	V _{DD}	2.6	6.5	V
Error Amplifier Input Voltage	V _I	0.5	1.6	V
Oscillator (OSC) Capacitance	C _{OSC}	100	10,000	pF
Oscillator (OSC) Resistance	R _{OSC}	1.0	10.0	kΩ
Oscillator (OSC) Frequency	f _{OSC}	10	1,000	kHz
Output Current	I _O		+30/-30	mA
Operating Free-Air Temperature	T _C	-20	+85	°C

**ELECTRICAL CHARACTERISTICS, $V_{DD} = 3.3V$ (UNLESS OTHERWISE SPECIFIED) (SEE NOTE 1)****OSCILLATOR**

PARAMETER	SYMBOL	TEST CONDITION	MIN	TYP	MAX	UNIT
Oscillation Frequency	f_{OSC}	$C_{OSC} = 270pF$ $R_{OSC} = 4.2k\Omega$	400	500	600	kHz
Frequency Variation with Temperature	$f_{\Delta T}$	$T_C = -20^{\circ}C$ to $+85^{\circ}C$		5		%
Frequency Input Stability	$f_{\Delta V}$	$V_{DD} = 2.6V$ to $6.5V$		1		%

UNDER-VOLTAGE PROTECTION

PARAMETER		TEST CONDITION	MIN	TYP	MAX	UNIT
Upper Threshold Voltage	V_{UPH}	$T_C = 25^{\circ}C$	2.12	2.47	2.85	V
Lower Threshold Voltage	V_{UPL}	$T_C = 25^{\circ}C$	1.96	2.28	2.63	V
Hysteresis ($V_{UPH} - V_{UPL}$)	V_{HYS}	$T_C = 25^{\circ}C$		0.19		V

Note 1: Typical values of all parameters are specified at $T_C = 25^{\circ}C$.

SHORT CIRCUIT PROTECTION CONTROL

PARAMETER		TEST CONDITION	MIN	TYP	MAX	UNIT
Input Threshold Voltage	V_{r1}		1.160	1.262	1.360	V
Short-Circuit Detection Threshold Voltage	V_{r2}		1.160	1.262	1.360	V
Charging Current	I_{SCP}	$V_{SCP} = 0V$	-2.15	-1.50	-1.00	μA

SOFT-START

PARAMETER		TEST CONDITION	MIN	TYP	MAX	UNIT
Charging Current	I_{CS}	$V_{SCP} = 0V$	-2.15	-1.50	-1.00	μA
Voltage at Soft-Start Completion	V_{ts}		1.160	1.262	1.360	V

SHUTDOWN CONTROL

PARAMETER		TEST CONDITION	MIN	TYP	MAX	UNIT
Shutdown Enable Voltage	V_{SE}				0.5	V
Shutdown Release Voltage	V_{SR}		2.0			V

– 台灣類比科技股份有限公司 –
– Advanced Analog Technology, Inc. –



ELECTRICAL CHARACTERISTICS, $V_{DD} = 3.3V$ (UNLESS OTHERWISE SPECIFIED (SEE NOTE 1))

IDLE PERIOD ADJUSTMENT SECTION

PARAMETER		TEST CONTION	MIN	TYP	MAX	UNIT
Maximum Duty Cycle	t_{Duty}	$C_{OSC} = 270pF$ $R_{OSC} = 4.2k\Omega, V_{OE} = 1.12V$	75	85	93	%

EA (ERROR AMPLIFIER)

PARAMETER		TEST CONDITION	MIN	TYP	MAX	UNIT
Input Threshold Voltage	V_T	$V_{OE} = 0.7V$	1.249	1.262	1.275	V
V_T Input Stability	V_{TAV}	$V_{DD} = 2.6$ to $6.5V$		2	8	mV
V_T Variation with Temperature	V_{TAT}	$T_C = -20^\circ C$ to $+85^\circ C$		1		%
Input Bias Current	I_B			0.1	1.0	μA
Output Voltage Swing	V_{OS+}		1.4	1.7		V
	V_{OS-}			0.05	0.20	
Output Sink Current	I_{OS+}	$V_{OE} = 0.7V$	3	20		mA
Output Source Current	I_{OS-}	$V_{OE} = 0.7V$	-45	-75		μA
Open-Loop Voltage Gain	A_{VO}		70	85		dB

OUTPUT SECTION

PARAMETER		TEST CONDITION		TYP	MAX	UNIT
High-Level Output Voltage	V_{OH}	$I_o = -30mA$	1.9	2.3		V
Low-Level Output Voltage	V_{OL}	$I_o = +30mA$		0.8	1.2	V
Rise Time	t_{RISE}	$C_L = 1,000pF$		100		ns
Fall Time	t_{FALL}	$C_L = 1,000pF$		100		ns

OPERATING CURRENT

PARAMETER		TEST CONDITION	MIN	TYP	MAX	UNIT
Supply Current	I_{DD-OFF}	Output "OFF" State		1.3		mA
	I_{DD-ON}	$R_{OSC} = 4.2k\Omega$		1.6		mA



HOW TO SET THE TIME CONSTANT FOR SOFT-START AND SHORT CIRCUIT PROTECTION

1. Soft-Start

AAT1109 operates in soft-start mode. The PWM comparator monitors the voltage at soft-start setting and SCP pin, which varies proportionally to each other. This proportion relation controls the ON duty of the OUT pin and activates the soft-start operation. In the Soft-start mode, the voltage at SCP pin (V_{SCP}) is input to the PWM comparator, so that the ON duty of the OUT pin is determined by the V_{SCP} . When the soft-started mode is completed, its setting voltage remains high and the circuit enters the output short circuit protection wait state while V_{SCP} remains low.

Soft-Start Time

$$t_s(sec) \sim 0.84 \times C_{SCP}(\mu F)$$

2. Short Circuit Protection

In response to a sudden drop of the switching regulator output, the device locks the error amplifier, OE pin, at V_{OS+} , and starts feeding currents into the capacitor at SCP pin to achieve in a voltage value of approximately 0.84V at this pin. This chain reaction protects the circuit by keeping the SCP pin and output pin low. Users could reverse this process by restarting the device.

Short Circuit Detection Time

$$t_{SCP}(sec) \sim 0.84 \times C_{SCP}(\mu F)$$



BLOCK DIAGRAM

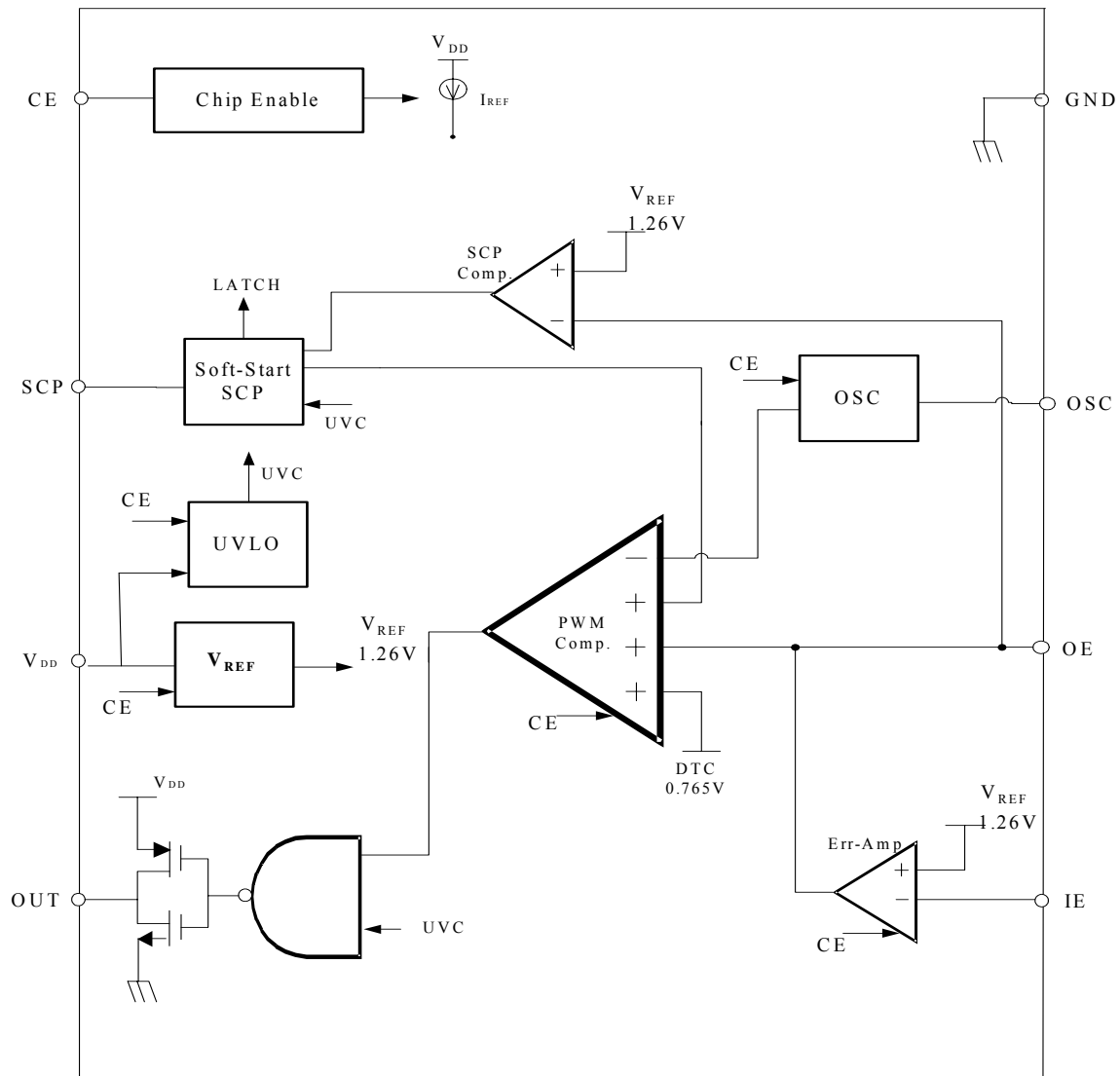

– 台灣類比科技股份有限公司 –
– Advanced Analog Technology, Inc. –



APPLICATION CIRCUIT 1 BOOST (STEP-UP)

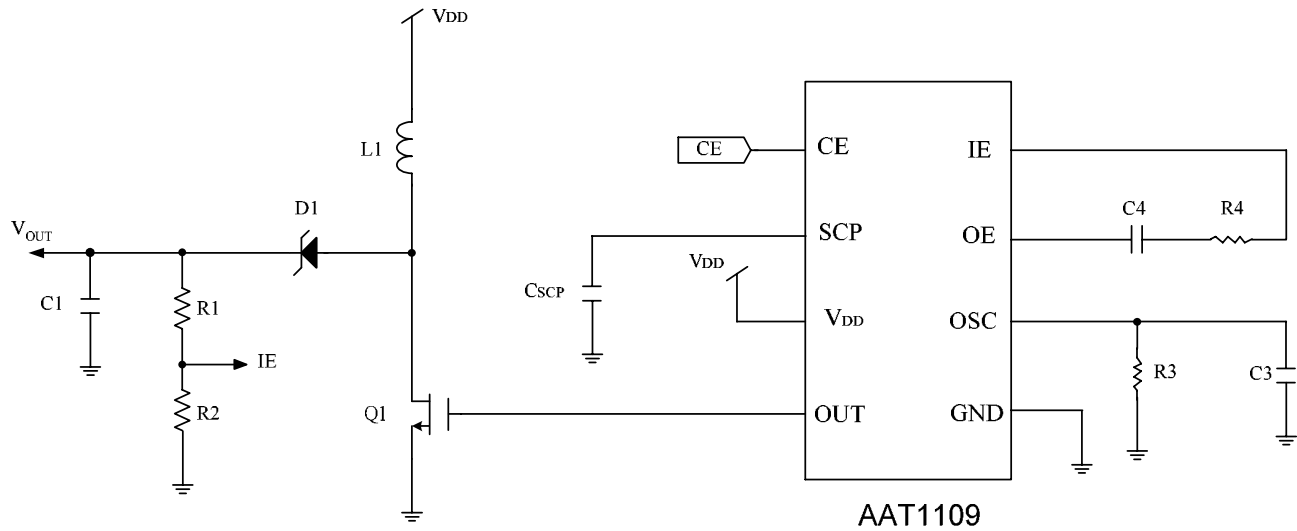



APPLICATION CIRCUIT 2 (WITH CHARGE PUMP)

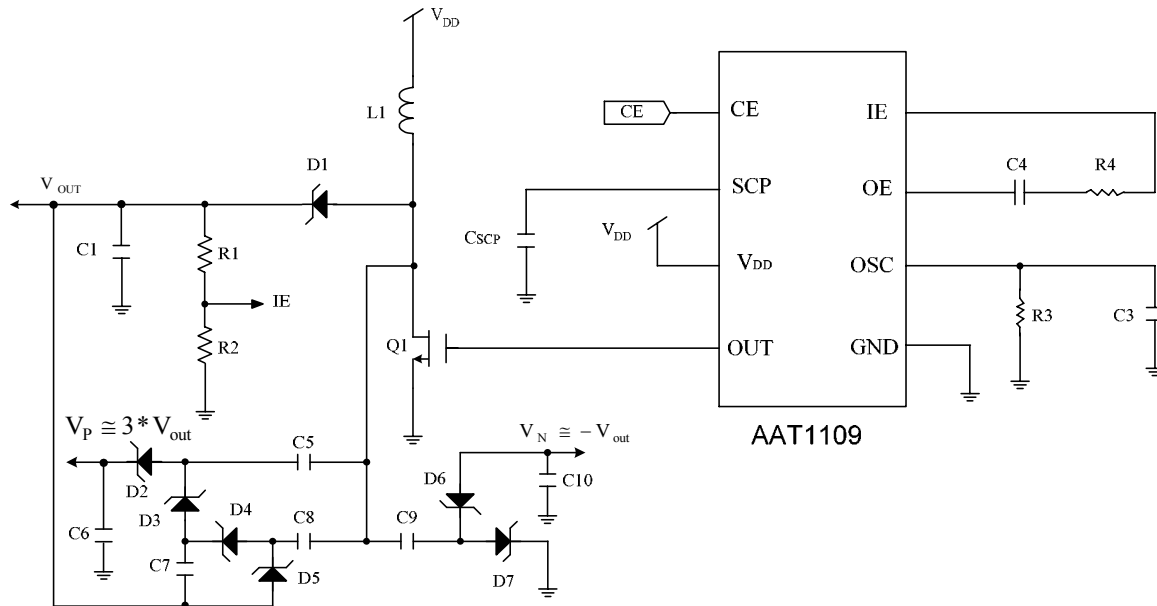



BOOST (STEP-UP) TIMING CHART

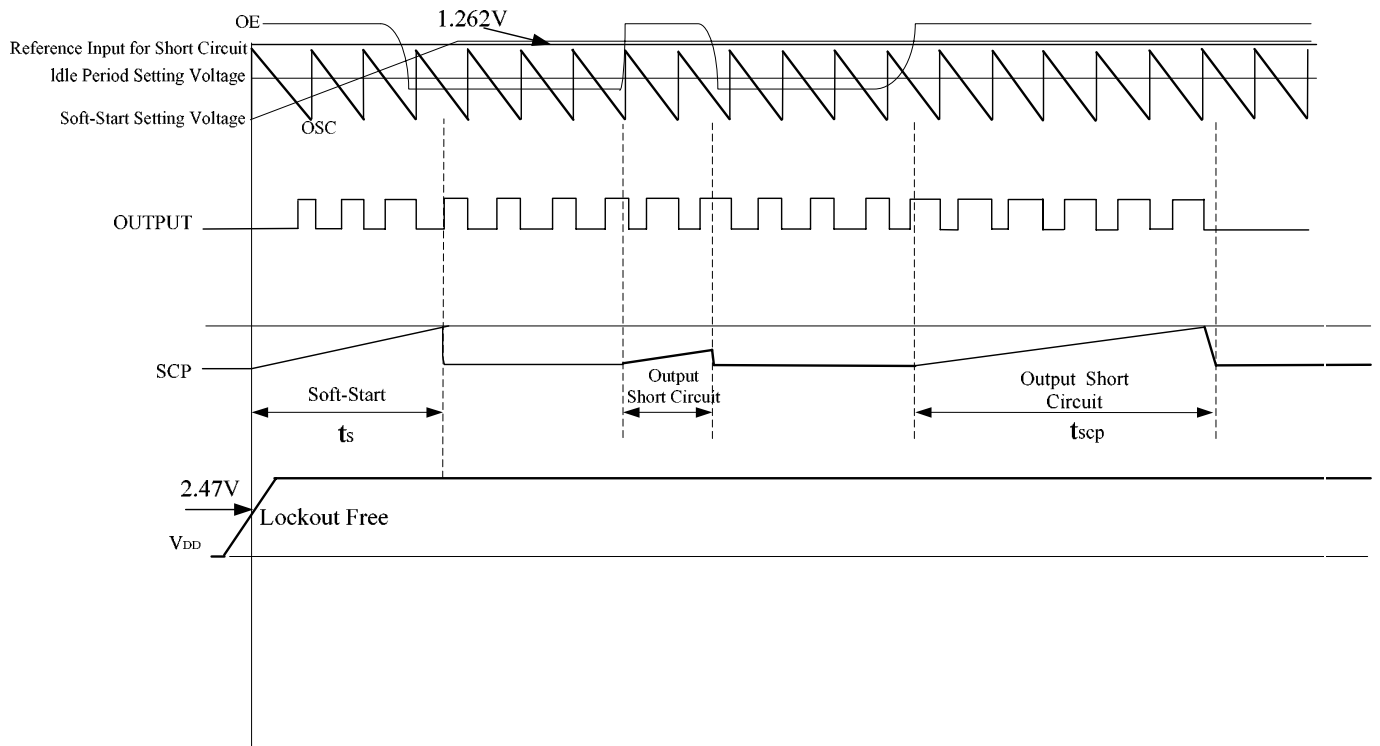



PACKAGE DIMENSION
8-PIN SOP

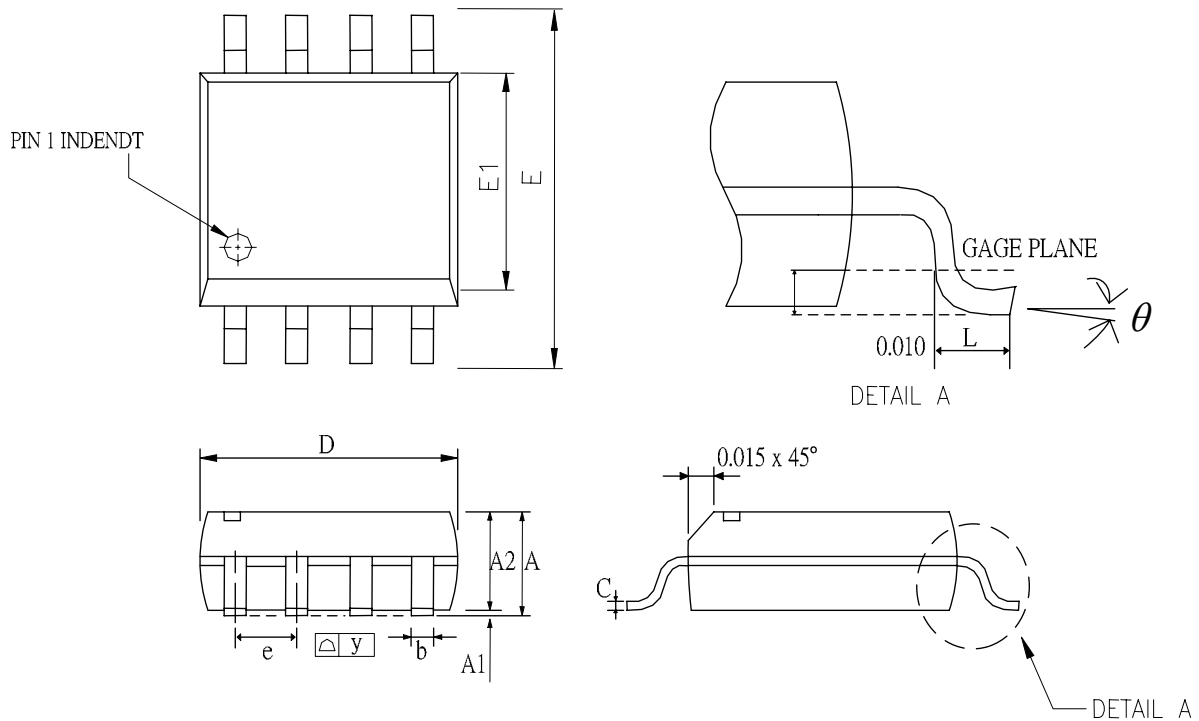

SYMBOLS	DIMENSIONS IN MILLIMETERS			DEMINSIONS IN INCHES		
	MIN	TYP	MAX	MIN	TYP	MAX
A	1.47	1.60	1.73	0.058	0.063	0.068
A1	0.10	---	0.22	0.004	---	0.008
A2	---	1.45	---	---	0.057	---
b	0.33	0.41	0.51	0.013	0.016	0.020
C	0.19	0.20	0.25	0.0075	0.008	0.0098
D	4.80	4.85	4.95	0.189	0.191	0.195
E	5.80	6.00	6.20	0.228	0.236	0.244
E1	3.80	3.90	4.00	0.150	0.154	0.157
e	---	1.27	---	---	0.050	---
L	0.38	0.71	1.27	0.015	0.028	0.050
y	---	---	0.076	---	---	0
θ	0	---	0	0	---	0



TAPE AND REEL
8-PIN SOP

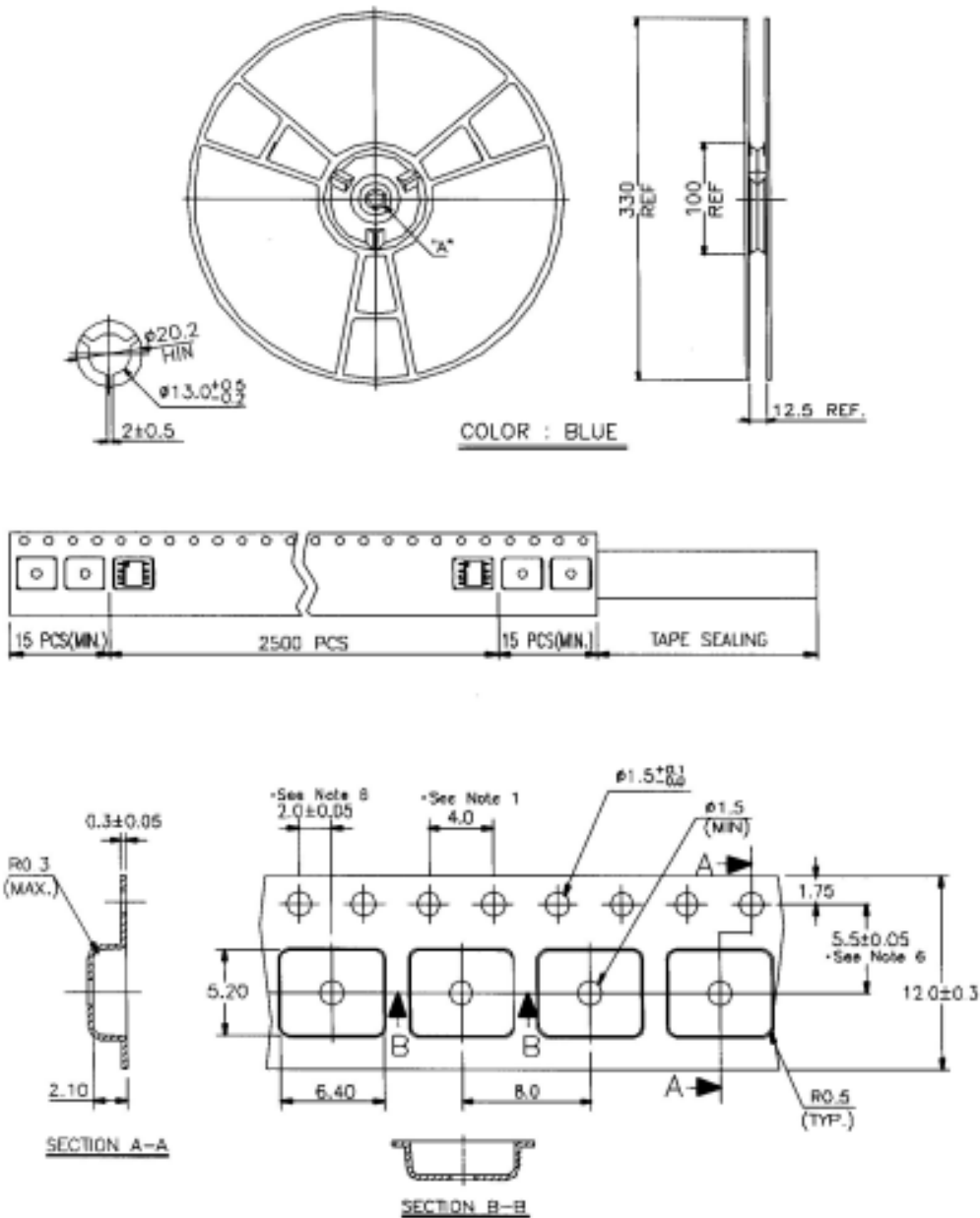

– 台灣類比科技股份有限公司 –
– Advanced Analog Technology, Inc. –



TAPE AND REEL
8-PIN SOP (CONT.)

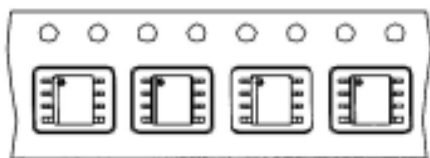

SOP 8N(150mil)

NOTE:

1. 10 SPROCKET HOLE PITCH CUMULATIVE TOLERANCE ± 0.2 MILLIMETERS.
2. CAMBER NOT TO EXCEED 1 MILLIMETER IN 100 MILLIMETERS
3. MATERIAL: ANTI-STATIC BLACK ADVANTEK POLYSTYRENE.
4. A_0 AND B_0 ARE MEASURED ON A PLANE 0.3 MILLIMETERS ABOVE THE BOTTOM OF THE POCKET.
5. K_0 IS MEASURED FROM A PLANE ON THE INSIDE BOTTOM OF THE POCKET TO THE TOP SURFACE OF THE CARRIER.
6. POCKET POSITION RELATIVE TO SPROCKET HOLE IS MEASURED AS TRUE POSITION OF POCKET, NOT POCKET HOLE.



PACKAGE DIMENSION
TSSOP-8

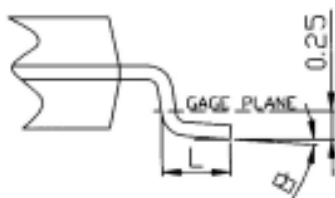
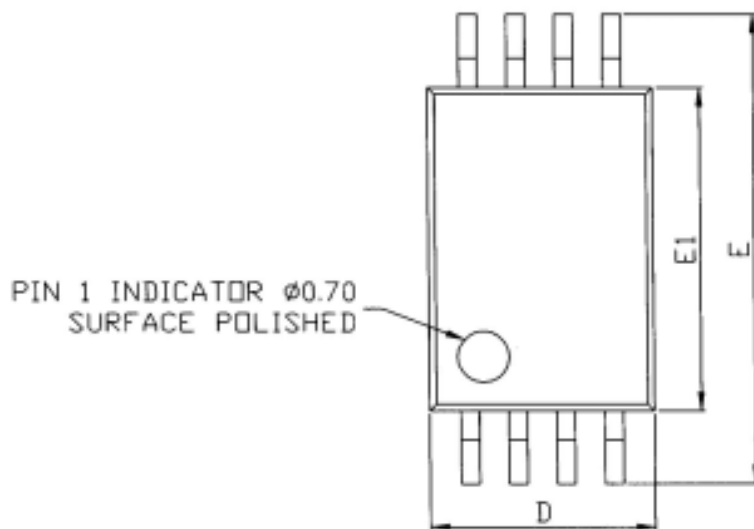

DETAIL A





PACKAGE DIMENSION
TSSOP-8

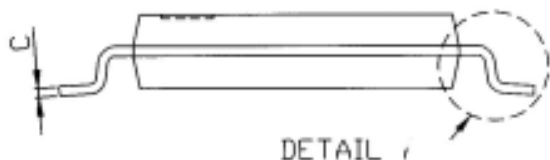

SYMBOL	DIMENSION IN MILLIMETERS			DIMENSION IN INCHES		
	MIN	TYP	MAX	MIN	TYP	MAX
A	1.05	1.10	1.20	0.041	0.043	0.047
A1	0.05	0.10	0.15	0.002	0.004	0.006
A2	-----	1.00	1.05	-----	0.039	0.041
b	0.25	-----	0.30	0.010	-----	0.012
C	-----	0.127	-----	-----	0.005	-----
D	2.90	3.05	3.10	0.114	0.120	0.122
E	6.20	6.40	6.60	0.244	0.252	0.260
E1	4.30	4.40	4.50	0.169	0.173	0.177
e	-----	0.65	-----	-----	0.026	-----
L	0.50	0.60	0.70	0.020	0.024	0.028
y	-----	-----	0.076	-----	-----	0.003
θ	0°	4°	8°	0°	4°	8°

NOTE:

1. CONTROLLING DIMENSION: MILLIMETERS.
2. LEAD FRAME MATERIAL: OLIN C7025/EFTEC 64T.
3. DIMENSION "D" DOES NOT INCLUDE MOLD FLASH, TIE BAR BURRS AND GATE BURRS. MOLD FLASH, TIE BAR BURRS AND GATE BURRS SHALL NOT EXCEED 0.006" [0.15 MILLIMETERS] PER END. DIMENSION "E1" DOES NOT INCLUDE INTERLEAD FLASH. INTERLEAD FLASH SHALL NOT EXCEED 0.010" [0.25 MILLIMETERS] PER SIDE.
4. DIMENSION "b" DOES NOT INCLUDE DAMBAR PROTRUSION. ALLOWABLE DAMBAR PROTRUSION SHALL BE 0.003" [0.08 MILLIMETERS] TOTAL IN EXCESS OF THE "b" DIMENSION AT MAXIMUM MATERIAL CONDITION. DAMBAR CANNOT BE LOCATED ON THE LOWER RADIUS OR THE FOOT. MINIMUM SPACE BETWEEN PROTRUSION AND AN ADJACENT LEAD TO BE 0.0028" [0.07 MILLIMETERS].
5. TOLERANCE: ± 0.010" [0.25 MILLIMETERES] UNLESS OTHERWISE SPECIFIED.
6. OTHERWISE DIMENSION FOLLOW ACCEPTABLE SPEC.
7. REFERENCE DOCUMENT: JEDEC SPEC MO-153.



TAPE AND REEL
TSSOP-8

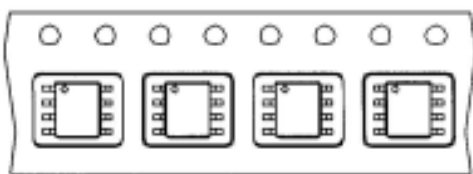
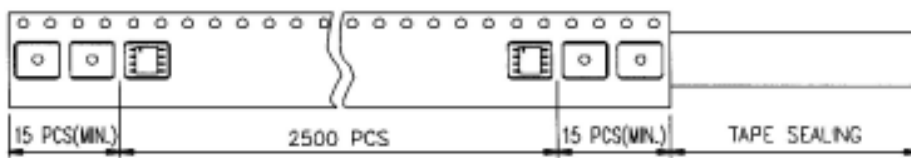
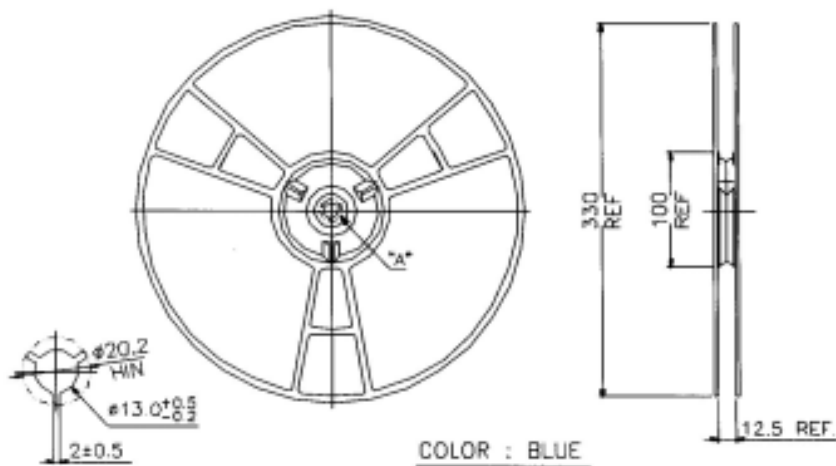

TSSOP 8L



**TAPE AND REEL
TSSOP-8 (CONT.)**

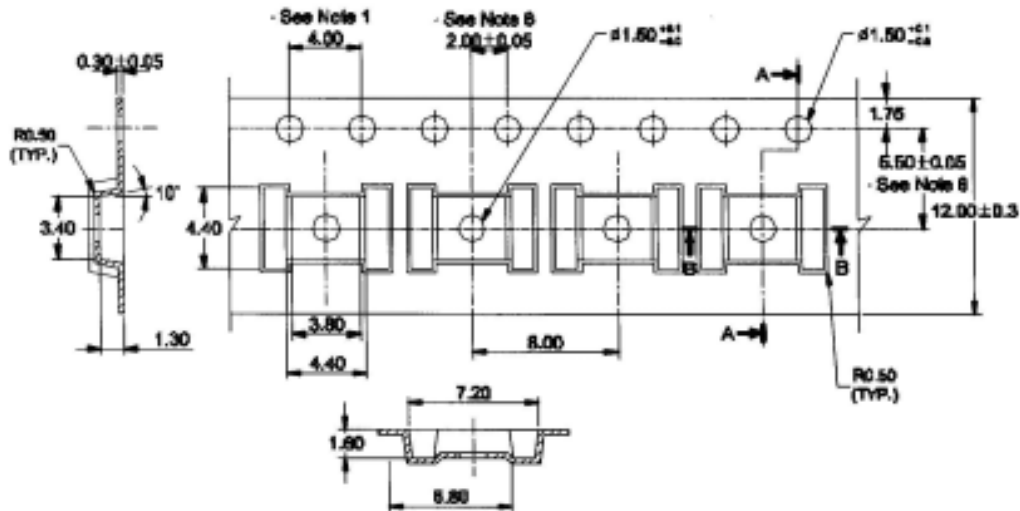

X.XXX X ± 0.0025
X.XXX ± 0.006
X.XX ± 0.025
X.X ± 0.10
X ± 0.25
UNIT: MILLIMETERS

NOTE:

1. 10 SPROCKET HOLE PITCH CUMULATIVE TOLERANCE ± 0.2 MILLIMETERS.
2. CAMBER NOT TO EXCEED 1 MILLIMETER IN 100 MILLIMETERS.
3. MATERIAL: ANTI-STATIC BLACK ADVANTEK POLYSTYRENE.
4. A₀ AND B₀ ARE MEASURED ON A PLANE 0.3 MILLIMETERS ABOVE THE BOTTOM OF THE POCKET.
5. K₀ IS MEASURED FROM A PLANE ON THE INSIDE BOTTOM OF THE POCKET TO THE TOP SURFACE OF THE CARRIER.
6. POCKET POSITION RELATIVE TO SPROCKET HOLE IS MEASURED AS TRUE POSITION OF POCKET, NOT POCKET HOLE.



PART MARKING

SOP8 TOP MARKING

AAT1109
XXXXXX

SOP8 BACK MARKING

YYWW

PART MARKING

TSSOP8 TOP MARKING

AAT1109
XXXXXX

TSSOP8 BACK MARKING

YYWW



ORDERING INFORMATION

