



Details are subject to change without notice.

## BUCK BOOST & BOOST PWM CONTROLLER WITH ADJUSTABLE LDO

### FEATURES

- Complete PWM Power Control Circuitry  
CH1: Buck\_Boost, CH2: Boost
- Adjustable Low Dropout (LDO) Regulator
- Under-Voltage Lockout (UVLO) Protection
- Totem Pole Output
- Output Short Circuit Protection
- Dead Time Control : 0% to 100%
- Wide Operating Frequency:  
10kHz to 800kHz

### GENERAL DESCRIPTION

The AAT1107 provides an integrated two-channel pulse-width-modulation (PWM) solution for the power supply of DC-DC system. This device offers system engineers the flexibility to tailor-make the power supply circuitry for the specific applications.

Each channel contains its own error amplifier, PWM comparator, dead-time control (DTC) and output driver. The two channels share common features of under-voltage protection, oscillator, short circuit protection and voltage reference circuit. Two dead-time control inputs are assigned for channel (CH1) and channel 2 (CH2) individually, and dead-time control inputs can be used to control on/off operation.

The AAT1107 contains one step-up (boost) circuit at CH2 and one inverting (buck\_boost) circuit at CH1. In addition, DTC can be set to provide 0% to 100% dead-time through a resistive divider network and soft-start can be implemented by paralleling the DTC resistor with a capacitor.

The Maximum output current of LDO regulator can be enlarged by connecting an nMOSFET (or NPN bipolar) as a source follower stage at OUT3 pin.

### PIN CONFIGURATION

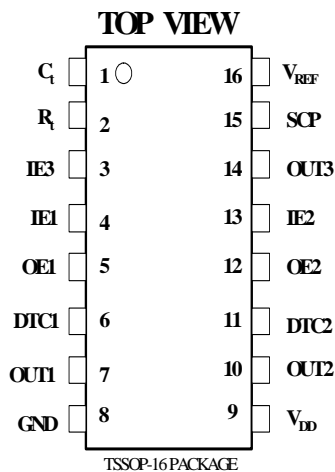

**PIN DESCRIPTION**

Pin No	Name	I/O	Description
1	$C_t$	-	External Timing Capacitance
2	$R_t$	-	External Timing Resistance
3	IE3	I	Inverting Input of LDO Regulator
4	IE1	I	Inverting Input of Error Amplifier 1
5	OE1	O	Output of Error Amplifier 1
6	DTC1	I	Output 1 Dead-Time / Soft-Start Setting
7	OUT1	O	Output 1
8	GND	-	Ground
9	$V_{DD}$	-	Power Supply
10	OUT2	O	Output 2
11	DTC2	I	Output 2 Dead-Time / Soft-Start Setting
12	OE2	O	Output of Error Amplifier 2
13	IE2	I	Inverting Input of Error Amplifier 2
14	NE2	O	LDO Output
15	SCP	-	Timer Latch Setting
16	$V_{REF}$	O	Reference Voltage (2.505V) Output

**ABSOLUTE MAXIMUM RATINGS**

Characteristics	Symbol	Value	Unit
Supply Voltage	$V_{DD}$	7.0	V
Input Voltage (IE <sub>-</sub> , DTC)	$V_I$	$V_{DD}$	V
Output Voltage	$V_O$	$V_{DD}+0.3$	V
Output Current	$I_O$	-120/+120	mA
Operating Free-Air Temperature Range	$T_C$	-20 to +85	°C
Storage Temperature Range	$T_{storage}$	-45 to +125	°C
Power Dissipation	$P_d$	500	mW

**RECOMMENDED OPERATING CONDITIONS**

	Symbol	Min	Max	Unit
Supply Voltage	$V_{DD}$	4.0	6.5	V
Input Voltage, IE1, IE2, IE3	$V_{cm}$	0.5	1.6	V
Output Voltage	$V_O$	0	$V_{DD}$	V
Oscillator (OSC) Capacitance	$C_{OSC}$	100	15,000	pF
Oscillator (OSC) Resistance	$R_{OSC}$	5.1	50.0	kΩ
Oscillation (OSC) Frequency	$f_{OSC}$	10	800	kHz
Output Current, $I_{OUT1}$ , $I_{OUT2}$	$I_{O12}$	-	+50/-50	mA
Output Current, $I_{OUT3}$	$I_{O3}$	-	30	mA
Operating Free-Air Temperature	$T_C$	-20	85	°C



**ELECTRICAL CHARACTERISTICS,  $V_{DD} = 5.0V$  (UNLESS OTHERWISE SPECIFIED) (SEE NOTE 1)**

**Oscillator**

Parameter	Symbol	Test Condition	Min	Typ	Max	Unit
Frequency	$f_{OSC}$	$C_{OSC} = 220pF,$ $R_{OSC} = 10k\Omega$	320	400	480	kHz
Frequency Change with $V_{DD}$	$f_{\Delta V}$	$V_{DD} = 4.0V$ to $6.0V$ $T_C = 25^\circ C$ $C_{OSC} = 220pF$ $R_{OSC} = 10k\Omega$	-	1	-	%

**Under-Voltage Protection**

Parameter	Symbol	Test Condition	Min	Typ	Max	Unit
Upper Threshold Voltage	$V_{UPH}$	$T_C = 25^\circ C$	2.6	2.9	3.2	V
Lower Threshold Voltage	$V_{UPL}$	$T_C = 25^\circ C$	2.23	2.53	2.83	V
Hysteresis ( $V_{UPH} - V_{UPL}$ )	$V_{HYS}$	$T_C = 25^\circ C$	-	0.37	-	V

**Short Circuit Protection Control**

Parameter	Symbol	Test Condition	Min	Typ	Max	Unit
Input Threshold Voltage	$V_{r2}$	CH2	2.10	2.40	2.65	V
Input Threshold Voltage	$V_{r1}$	CH1	0.95	1.05	1.15	V
Input Threshold Voltage	$V_{r3}$	CH3	-	1.05	-	
Short-Circuit Detect Threshold Voltage	$V_{tscd}$		1.48	1.64	1.80	V
SCP Terminal Source Current	$I_{SCP}$		-3.5	-2.5	-1.5	$\mu A$
Stand-by Voltage	$V_{STB}$		-	50	100	mV
Latch Voltage	$V_{LT}$		-	30	100	mV

Note 1: Typical values of all parameters are specified at  $T_C = 25^\circ C$ .



**ELECTRICAL CHARACTERISTICS,  $V_{DD} = 5.0V$  (UNLESS OTHERWISE SPECIFIED) (SEE NOTE 1) (CONT.)**

**Reference Voltage**

Parameter	Symbol	Test Condition	Min	Typ	Max	Unit
Internal Reference Voltage	$V_{REFi}$	$I_{REF} = -1mA, T_C = 25^\circ C$	1.220	1.233	1.246	V
Reference Voltage	$V_{REF}$	$I_{REF} = -1mA, T_C = 25^\circ C$	2.430	2.505	2.580	
Input Voltage Regulation	$V_{RI}$	$I_{REF} = -1mA,$ $V_{DD} = 4.0V \text{ to } 6.0V$	-	1	5	mV
Output Regulation	$V_{RO}$	$I_{REF} = -0.1mA \text{ to } -1mA$	-	1	-	mV

**EA (Error Amplifier)**

Parameter	Symbol	Test Condition	Min	Typ	Max	Unit
Input Offset Voltage	$V_{IO}$	CH1, CH2, Unity Gain	-	-	6	mV
Input Bias Current	$I_{IB}$	CH1, CH2	-	$\pm 15$	$\pm 100$	nA
Input Voltage Range	$V_{IR}$	CH1, CH2	0.5	-	1.6	V
Open-Loop Voltage Gain	$A_{VO}$		70	85	-	dB
Output Voltage Swing	$V_{OS+}$		2.3	2.5	-	V
	$V_{OS-}$		-	0.7	0.9	
Output Sink Current	$I_{OS+}$	OE=1.25V	3	20	-	mA
Output Source Current	$I_{OS-}$	OE=1.25V	-	-75	-45	$\mu A$
Common-Mode Rejection Ratio	CMRR		60	80	-	dB

**Operating Current**

Parameter	Symbol	Test Condition	Min	Typ	Max	Unit
Supply Current	$I_{DD-OFF}$	Output "OFF" State	-	1.8	-	mA
	$I_{DD-ON}$	$R_{OSC} = 10k\Omega$	-	2.0	-	mA



**ELECTRICAL CHARACTERISTICS,  $V_{DD} = 5.0V$  (UNLESS OTHERWISE SPECIFIED) (SEE NOTE 1) (CONT.)**

**Dead-Time Control & PWM**

PARAMETER	Symbol	TEST CONDITION	MIN	TYP	MAX	UNIT
Input Bias Current	$I_{IB}$	$V_{DTC}=2V$	-	0.1	1.0	V
Input Threshold Voltage (DTC1)	$V_{1d0}$	Duty=0%, $f_{OSC}=10kHz$	1.87	1.97	2.07	V
	$V_{1d100}$	Duty=100%, $f_{OSC}=10kHz$	1.38	1.48	1.58	
Input Threshold Voltage (DTC2)	$V_{2d0}$	Duty=0%, $f_{OSC}=10kHz$	1.38	1.48	1.58	V
	$V_{2d100}$	Duty=100%, $f_{OSC}=10kHz$	1.87	1.97	2.07	
Latch Input Voltage (DTC1)	$V_{1DTC}$	$I_{DTC} = 40\mu A$	2.28	2.48	-	V
Latch Input Voltage (DTC2)	$V_{2DTC}$	$I_{DTC} = 100\mu A$	-	0.1	0.3	V
Latch Mode Source Current (DTC1)	$I_{1DTC}$	DTC1=0V	-	-560	-200	$\mu A$
Latch Mode Source Current (DTC2)	$I_{2DTC}$	DTC2=2.0V	-	-560	-200	$\mu A$

**Output Stage**

Parameter	Symbol	Test Condition	Min	Typ	Max	Unit
High-Level Output Voltage	$V_{OH}$	$I_O = -50mA$	3.6	4.0	-	V
Low-Level Output Voltage	$V_{OL}$	$I_O = +50mA$	-	0.8	1.2	V
Rise Time	$t_{RISE}$	$C_L = 1,000pF$	-	100	-	ns
Fall Time	$t_{FALL}$	$C_L = 1,000pF$	-	100	-	ns
Leakage Current	$I_{LEAK}$	$V_O = 6.0V$	-	-	5.0	$\mu A$
Capacitance at the Output Pin	$C_L$		-	-	-	pF

**LDO**

Parameter	Symbol	Test Condition	Min	Typ	Max	Unit
Output Voltage	$V_{rd}$	$V_{DD}=5V, V_{OUT3}=3.3V$	3.17	3.30	3.43	V
Line Regulation	$LR_I$	$V_{DD}=4.0V\sim 6.5V,$ $I_{OUT3}=10mA$	-	0.08	0.30	%
Load Regulation	$LR_O$	$I_{OUT3}=1mA\sim 30mA$	-	0.1	-	%

– 台灣類比科技股份有限公司 –  
– Advanced Analog Technology, Inc. –





APPLICATION CIRCUIT 1

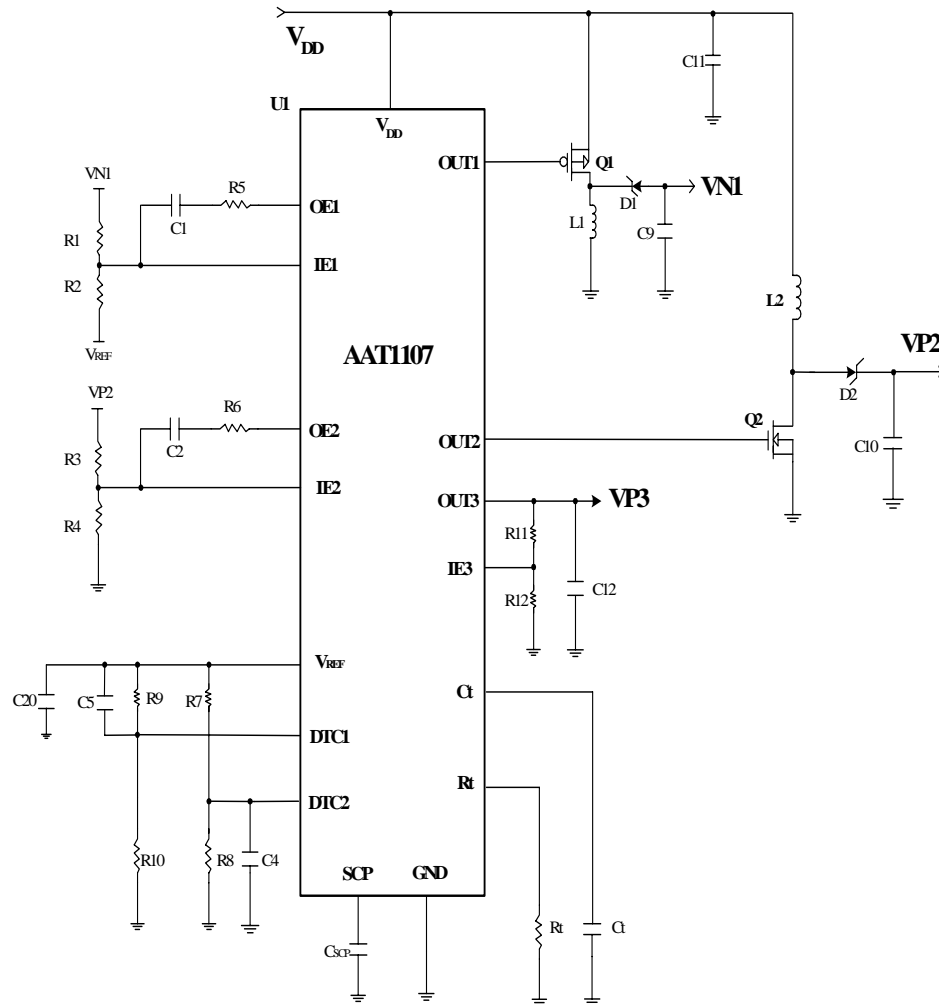





APPLICATION CIRCUIT 2

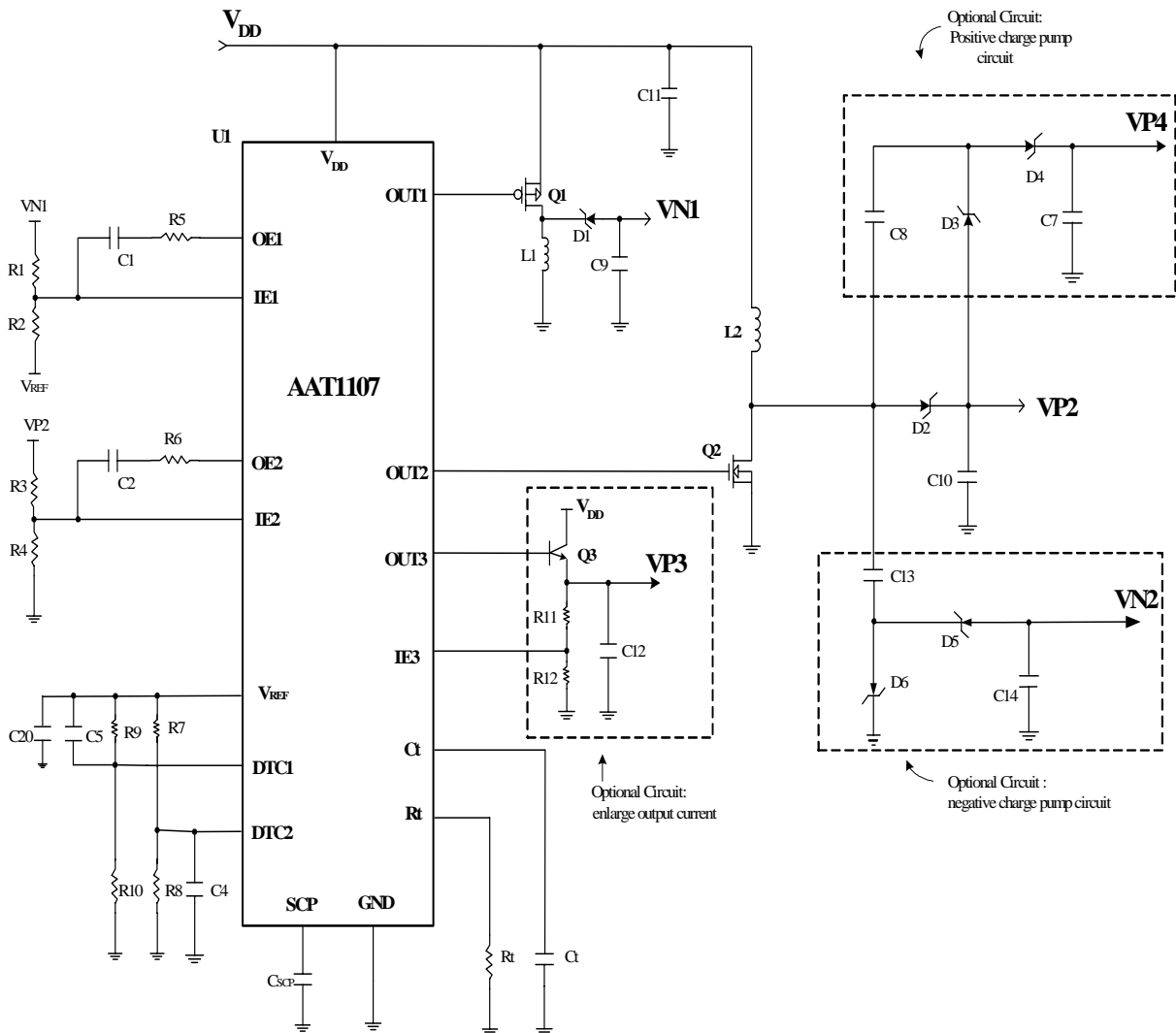



BUCK-BOOST (INVERTING) TIMING CHART (CH1)

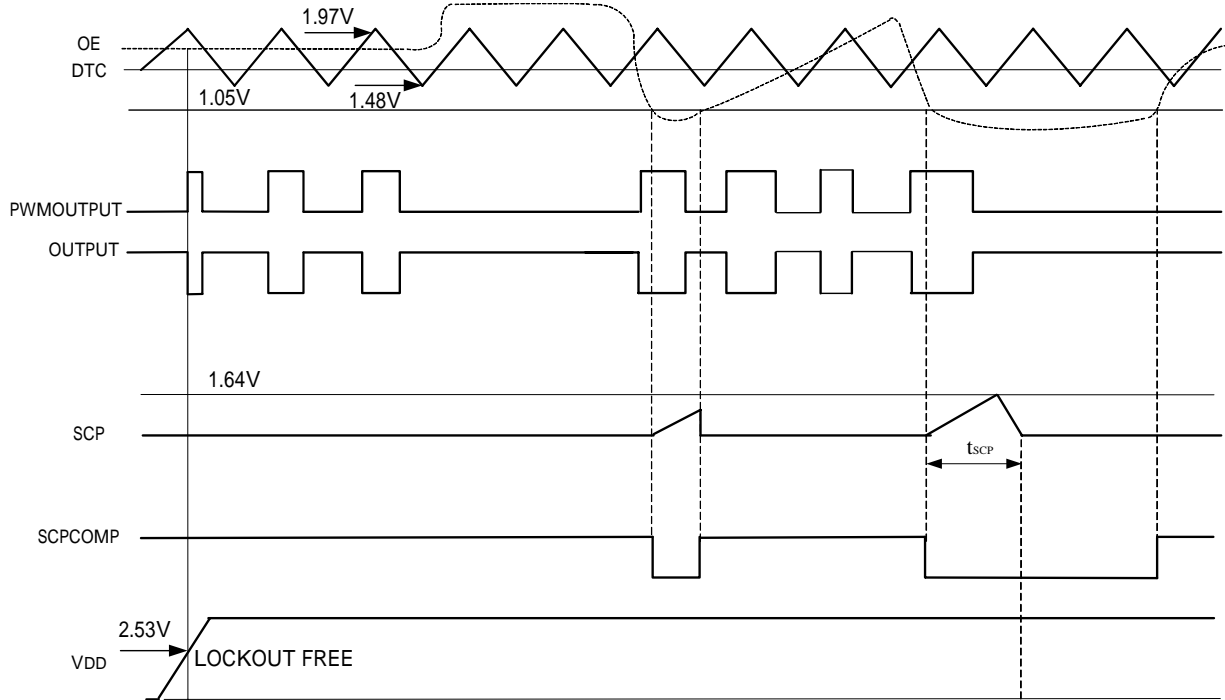

Note:  $t_{scp} \cong \frac{C_{SCP} V_{r2}}{I_{SCP}}$



**BOOST (STEP-UP) TIMING CHART (CH-2)**

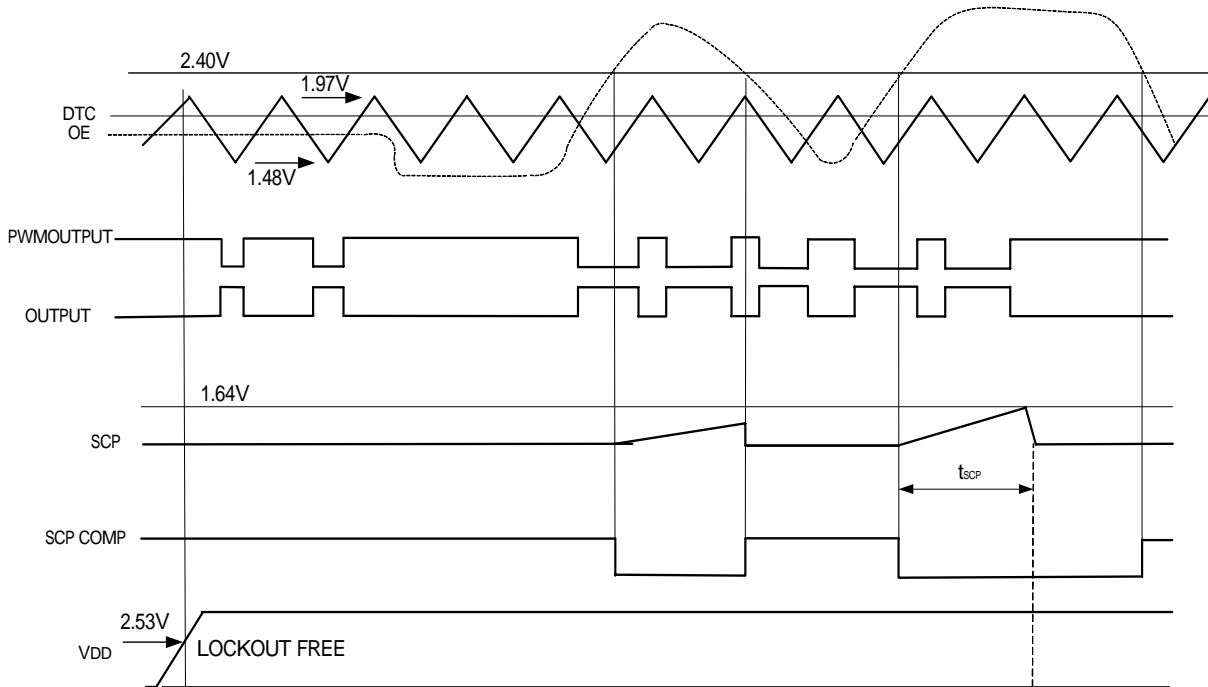

Note:  $t_{scp} \cong \frac{C_{SCP} V_{r2}}{I_{SCP}}$



**PACKAGE DIMENSION**  
**16-PIN TSSOP**

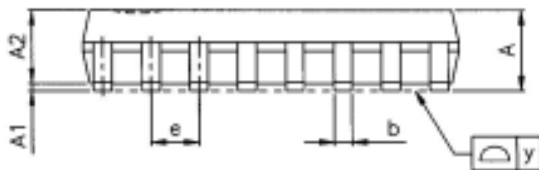
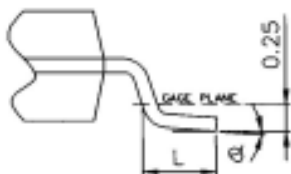
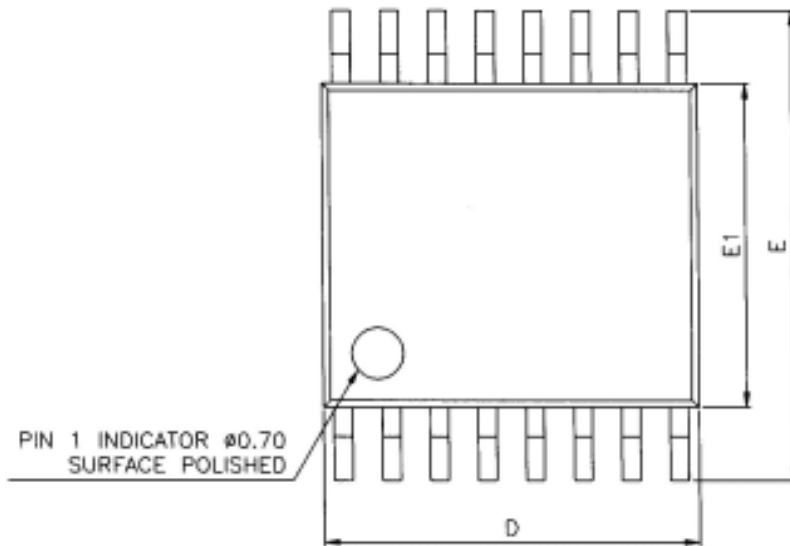



**PACKAGE DIMENSION (CONT.)**

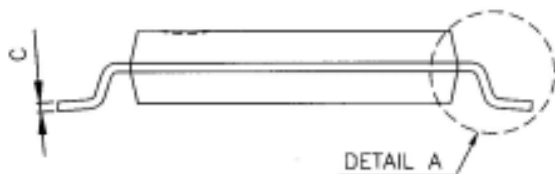

SYMBOLS	DIMENSIONS IN MILLIMETERS			DEMINSIONS IN INCHES		
	MIN	TYP	MAX	MIN	TYP	MAX
A	1.05	1.10	1.20	0.041	0.043	0.047
A1	0.05	0.10	0.15	0.002	0.004	0.006
A2	-----	1.00	1.05	-----	0.039	0.041
b	0.20	0.25	0.28	0.008	0.010	0.011
C	-----	0.127	-----	-----	0.005	-----
D	4.900	5.075	5.100	0.1930	0.1998	0.2000
E	6.20	6.40	6.60	0.244	0.252	0.260
E1	4.30	4.40	4.50	0.170	0.173	0.177
e	-----	0.65	-----	-----	0.026	-----
L	0.50	0.60	0.70	0.020	0.024	0.028
y	-----	-----	0.076	-----	-----	0.003
θ	0°	4°	8°	0°	4°	8°

NOTE:

1. CONTROLLING DIMENSION: MILLIMETERS
2. LEAD FRAME MATERIAL: OLIN C7025/EFTEC 64T
3. DIMENSION "D" DOES NOT INCLUDE MOLD FLASH, TIE BAR BURRS AND GATE BURRS. MOLD FLASH, TIE BAR BURRS AND GATE BURRS SHALL NOT EXCEED 0.006" [0.15 MILLIMETERS] PER END. DIMENSION "E1" DOES NOT INCLUDE INTERLEAD FLASH. INTERLEAD FLASH SHALL NOT EXCEED 0.010" [0.25 MILLIMETERS] PER SIDE.
4. DIMENSION "b" DOES NOT INCLUDE DAMBAR PROTRUSION. ALLOWABLE DAMBAR PROTRUSION SHALL BE 0.003" [0.08 MILLIMETERS] TOTAL IN EXCESS OF THE "b" DIMENSION AT MAXIMUM MATERIAL CONDITION. DAMBAR CANNOT BE LOCATED ON THE LOWER RADIUS OR THE FOOT. MINIMUM SPACE BETWEEN PROTRUSION AND AN ADJACENT LEAD TO BE 0.0028" [0.07 MILLIMETERS].
5. TOLERANCE: ± 0.010 [0.25 MILLIMETERS] UNLESS OTHERWISE SPECIFIED.
6. OTHERWISE DIMENSION FOLLOW ACCEPTABLE SPEC.
7. REFERENCE DOCUMENT: JEDEC SPEC MO-153.



**TAPE AND REEL**

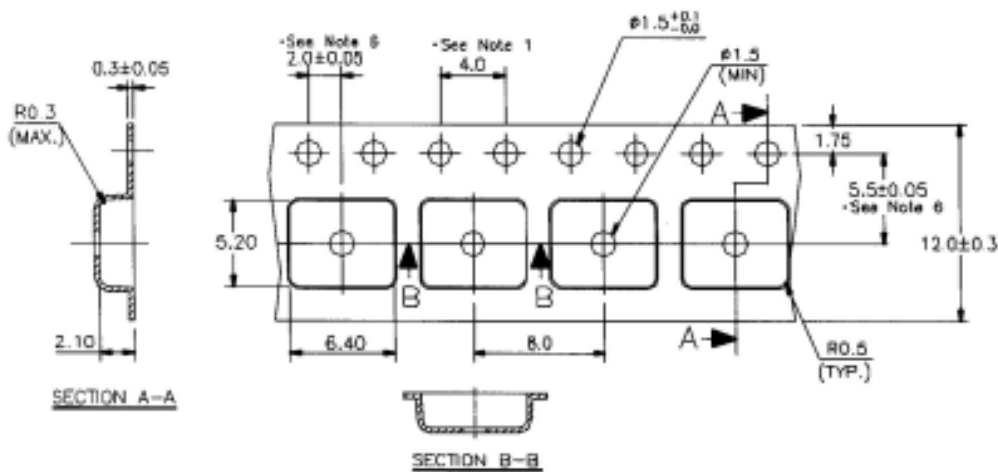
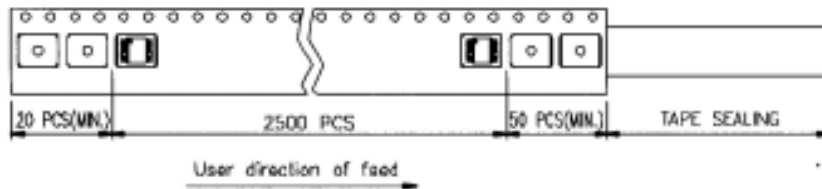
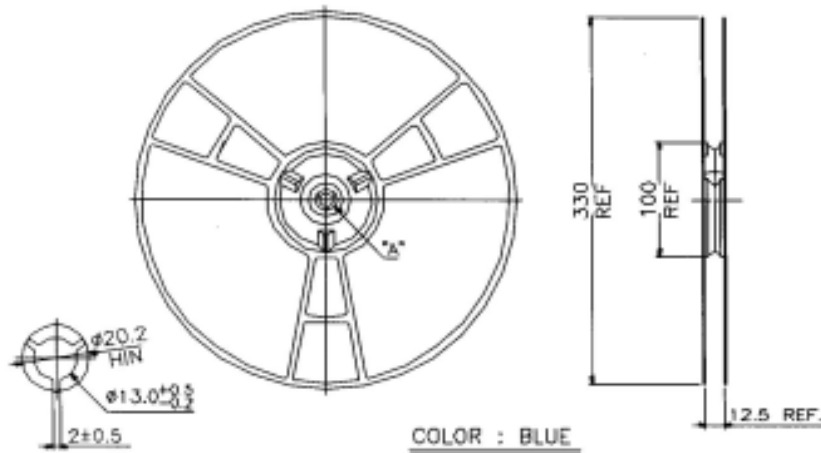



**TAPE AND REEL (CONT.)**

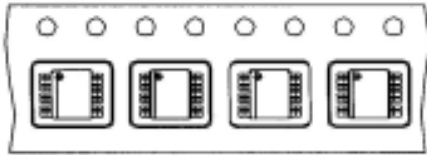

TSSOP 14L / 16L

**NOTE:**

1. 10 SPROCKET HOLE PITCH CUMULATIVE TOLERANCE  $\pm 0.2$  MILLIMETERS.
2. CAMBER NOT TO EXCEED 1 MILLIMETER IN 100 MILLIMETERS.
3. MATERIAL: ANTI-STATIC BLACK ADVANTEK POLYSTYRENE.
4.  $A_0$  AND  $B_0$  MEASURED ON A PLANE 0.3 MILLIMETERS ABOVE THE BOTTOM OF THE POCKET.
5.  $K_0$  MEASURED FROM A PLANE ON THE INSIDE BOTTOM OF THE POCKET TO THE TOP SURFACE OF THE CARRIER.
6. POCKET POSITION RELATIVE TO SPROCKET HOLE MEASURED AS TRUE POSITION OF POCKET, NOT POCKET HOLE.

**PART MARKING**

**TSSOP16 TOP MARKING**

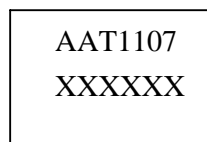

**TSSOP16 BACK MARKING**

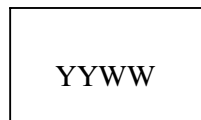



**ORDERING INFORMATION**

