



perfect in sensors.



POSIROT[®]
Magnetic Angle Sensors

POSIROT[®]
Magnetic Angle Encoders

POSITILT[®]
Magnetic Inclination Sensors



POSIROT® / POSITILT®

Angle Sensors and Encoders

Contents



Contents		Page
Model Selection Guide for POSIROT® and POSITILT®		3
The Company and the Products		4
POSIROT® and POSITILT® – The Functional Principles		5
PRAS1	Magnetic angle sensor, external magnet, with analog output	6
PRDS1	Magnetic angle encoder, external magnet, with incremental or SSI output	7/8
PRAS2	Magnetic angle sensor, external magnet, with analog output	10
PRDS2	Magnetic angle encoder, external magnet, with incremental or SSI output	11/12
PRAS20 / 21	Magnetic angle sensor, external magnet, voltage output	16
PRAS3	Magnetic angle sensor, solid or hollow shaft, with analog output	18
PRDS3	Magnetic angle encoder, solid or hollow shaft, with incremental or SSI output	19/20
PRAS4	Magnetic angle sensor, shaft or non-contact, with analog output	22
PTAS2	Magnetic inclination sensor with analog output	24
Output specifications		
I1, U2, U6	4 ... 20 mA (3 wire); 0.5 ... 10 V; 0.5 ... 4.5 V	26
Output signal for magnetic angle sensors		27
RS422	Incremental output RS422 compatible	28
SSI	Synchronous serial	29
Accessories		
Position magnets		30
Mounting plates		31
Connector cables		32
PMIS4/PMIR4	Magnetic incremental encoder	34
PMIS4/PMIR5	Magnetic incremental encoder	40
PRODIS-ADC	Digital process meter for analog sensors	42
PRODIS-INC	Digital process meter for incremental sensors	44
PRODIS-SSI	Digital process meter for sensors with SSI output	46
Other ASM products		50

The information presented in this catalog does not form part of any quotation or contract, is believed to be accurate and reliable and may be changed without notice. No liability will be accepted by ASM for any consequence of its use. Publication thereof does not convey nor imply any license under patent or industrial or intellectual property rights.

Applications that are described herein for any of these products are for illustrative purpose only. ASM makes no representation or warranty that such applications will be suitable for the specified use without further testing or modification.

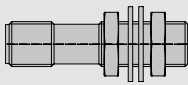
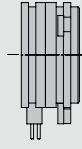
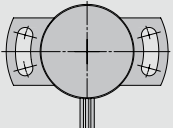
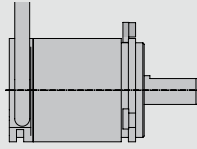
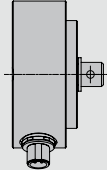
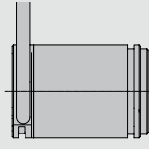
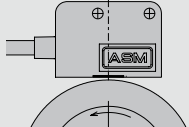
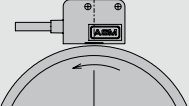

Model Selection Guide for POSIROT® and POSITILT®

Model	Outputs					Protection class	Special characteristics
	U2 (0.5...10 V)	U6 (0.5...4.5 V)	I1 (4...20 mA 3w)	Incremental	SSI		
PRAS1 / PRDS1 	•	•	•	•	•	IP67/ IP69K	<ul style="list-style-type: none"> • Magnetic non-contact with 360 degree range
PRAS2 / PRDS2 	•	•	•	•	•	IP67/ IP69K	<ul style="list-style-type: none"> • Non-contact with external position magnet • Wear free • 36 mm dia. housing • Redundant channel as option
PRAS20 / PRAS21 		•				IP60	<ul style="list-style-type: none"> • Non-contact with external position magnet • Wear free • Height only 6 mm • OEM version
PRAS3 / PRDS3 	•	•	•	•	•	IP67/ IP69K	<ul style="list-style-type: none"> • 10 mm shaft or 6 mm hollow shaft • Housing dia. 36 mm • Redundant channel as option
PRAS4 	•	•	•			IP67/ IP69K	<ul style="list-style-type: none"> • Magnetic measurement principle • 13 mm shaft or non-contact • Housing dia. 79 mm • Double-bearing shaft
PTAS2 	•	•	•			IP67/ IP69K	<ul style="list-style-type: none"> • Inclinometer • Magnetic measurement principle • Wear-free • Housing dia. 36 mm • Redundant channel as option
PMIS4 / PMIR4 				•		IP67	<ul style="list-style-type: none"> • Magnetic incremental encoder • Resolution up to 184,320 pulses per revolution • Resistant against shock, vibration, humidity and many liquids
PMIS4 / PMIR5 				•		IP67	<ul style="list-style-type: none"> • Magnetic incremental encoder • Resolution up to 327,680 pulses per revolution • Resistant against shock, vibration, humidity and many liquids

The Company and the Products



ASM is a leading company in the development and production of linear and angular position sensors. ASM sensors are used in industrial and commercial applications, where angle, inclination, displacement or position measurements are used to automate, test or monitor processes.

Innovative Technologies that Solve Your Measuring Requirements

Our product range consists of various technologies to measure linear and rotative positions. With over 25 years of experience in the position sensor market, ASM offers innovative solutions for the most demanding applications.

ASM Products Represent Quality and Reliability

The quality and precision of our products ensures consistent productivity. Our continuous research and development in our laboratories as well as our DIN EN 9001:2000 certified quality management system guarantees these high standards.

ASM – Global Supplier of Position Sensors

ASM products are sold world-wide through sales offices, subsidiaries and a network of 50 distributors. With this global presence we ensure being close to our customers and provide quick product availability wherever ASM sensors are needed.



The product range

- POSIROT® Magnetic Angle Sensors
- POSITILT® Magnetic Inclination Sensors
- POSICHRON® Magnetostrictive Position Sensors
- POSIMAG® Magnetic Scale Position Sensors
- WS® Cable Actuated Position Sensors
- PRODIS® Digital Process Displays



POSIROT® / POSITILT® Angle Sensors and Encoders The Functional Principle



PRAS/PRDS Series (POSIROT®)

The angle sensors of the **PRAS/PRDS series** are based on a contact-free and absolute measurement principle. The position sensing element is a permanent magnet.

Depending on the permanent magnet type, a tolerance in the air gap and axial offset is allowable within certain limits. The detected magnetic field vectors are transformed by an internal circuit board into standard 4-20 mA, 0.5-10 V and SSI output signals.

PMIS Series (POSIROT®)

The incremental encoder of the **PMIS series** consists of an XMR sensor head and a magnet ring as a magnetic scale. The circumference of the magnet ring contains a series of evenly spaced magnetic north and south poles.

The angular position is determined contact-free and wear-free by the sampling of the sinusoid magnetic field above the surface of the magnet ring by the XMR-sensor head. The air gap between the sensor head and the magnetic ring can be up to 2 mm for a ring with a 5 mm period. The sensor head generates 90° shifted sine/cosine signals, through the integrated signal interpolation circuit, these signals are combined with the reference mark signal and transformed without a time delay into a square-wave output.

PTAS Series (POSITILT®)

The **PTAS series** uses a pendulum with an internal position magnet to provide the inclination angle. The cavity surrounding the pendulum is filled with a specific fluid that can be varied depending upon the amount of motion damping is required.

The established PRAS2 or PRDS2 angle sensor is fitted into the PTAS2 housing. The stainless steel housing is thoroughly sealed and is rated up to IP69K, which makes it suitable for use in extreme environments found on cranes, off-highway construction equipment, ships and off-shore applications.

External magnetic fields due to power cables, magnetized materials or the earth's magnetic field do not influence the accuracy of the inclinometer. The PTAS series is completely encapsulated in a magnetically shielded housing and is immune against magnetic fields as far as possible.

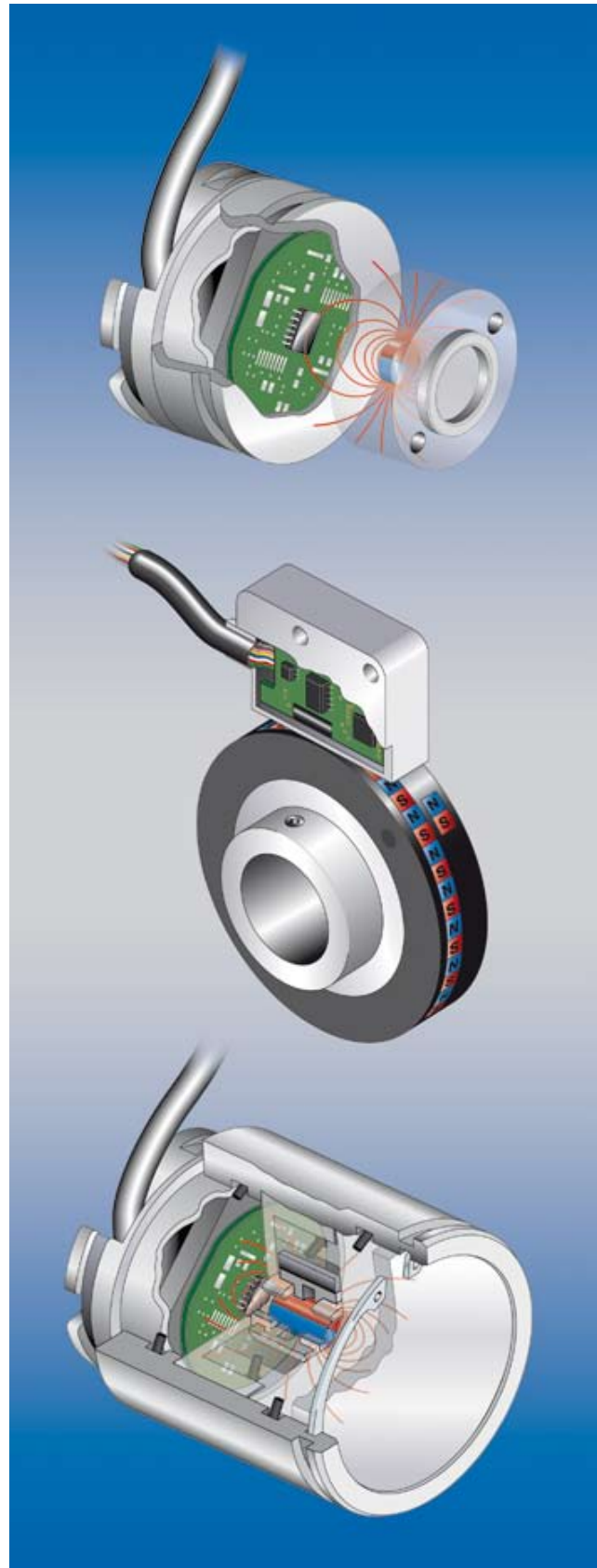

POSIROT®
PRAS1
Magnetic Angle Sensor with Analog Output



Magnetic angle sensor 0 - 360° in M12 housing

- Protection class IP67/IP69K
- Non-contact with external position magnet
- Wear free
- All metal housing
- Outputs:
 Voltage 0.5 ... 4.5 V, 0.5 ... 10 V
 Current 4 ... 20 mA

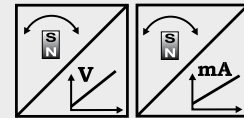

Specifications	Outputs	Voltage: 0.5 ... 4.5 V; 0.5 ... 10 V Current: 4 ... 20 mA, 3 wire
	Resolution	0.03 % (60 ... 360°); 0.1 % (15 ... 45°)
Repeatability	±0.03 % (60 ... 360°); ±0.1 % (15 ... 45°)	
Linearity	±0.3 % f.s. (typ.); a misalignment of the position magnet has an effect on the linearity (see page 30)	
Measurement range	0 ... 15° to 0 ... 360°, standard 360°	
Signal characteristics	CW, CCW	
Rated distance sensor / magnet	Depending on the position magnet, see page 30	
Material	Stainless steel / aluminium / zinc (depends on the model)	
Mounting	M12 x 1	
Protection class	IP67/IP69K (connector output with IP69K connector cable) IP67 (cable output)	
Shock	EN 60068-2-27:1993, 100 g/11 ms, 100 shocks	
Vibration	EN 60068-2-6:1995, 20 g 10 Hz-2 kHz, 10 cycles	

Order Code PRAS1

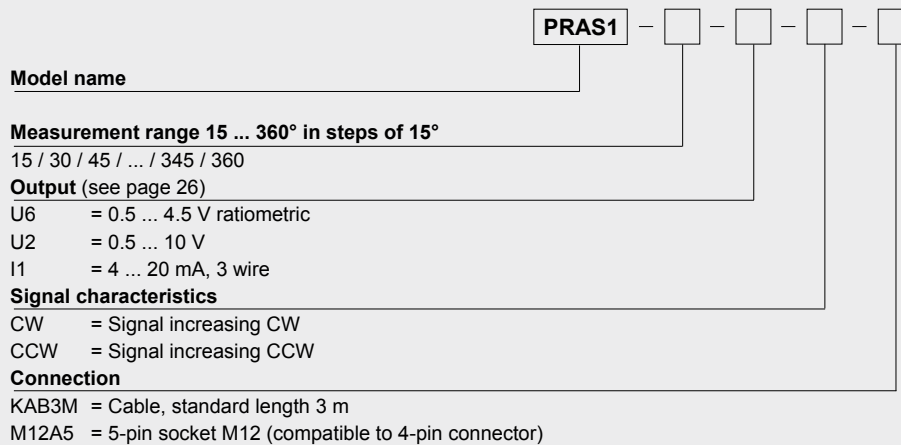

Order code position magnet (see accessories page 30)

PRMAG ...

Order code connector cable (see accessories page 32)

KAB-2M-M12/4F/G-LITZE

Order Example: PRAS1 - 360 - I1 - CW - M12A5

POSIROT®
PRDS1
Magnetic Angle Encoder with Incremental Output

PRELIMINARY



Magnetic angle encoder 0 - 360° in M12 housing

- Protection class IP67/IP69K
- Non-contact with external position magnet
- Wear free
- All metal housing
- Incremental encoder output

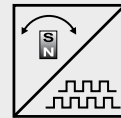

Specifications	Output	Incremental encoder outputs A, \bar{A} , B, \bar{B} , Z, \bar{Z} , RS422 compatible
	Resolution	128, 256, 512, 1024 pulses per revolution
	Linearity	$\pm 1^\circ$; a misalignment of the position magnet has an effect on the linearity (see page 30)
	Measurement range	0 ... 360°
	Max. revolutions	30,000 r.p.m.
	Max. output frequency	500 kHz (the quadrature counter of the subsequent circuit must be able to process >500 kHz)
	Rated distance sensor / magnet	Depending on the position magnet, see page 30
	Material	Stainless steel / aluminium / zinc (depends on the model)
	Mounting	M12 x 1
	Protection class	IP67/IP69K (connector output with IP69K connector cable) IP67 (cable output)
Shock	EN 60068-2-27:1993, 100 g/11 ms, 100 shocks	
Vibration	EN 60068-2-6:1995, 20 g 10 Hz-2 kHz, 10 cycles	

Order Code PRDS1

Model name

Resolution (pulses/revolution)

128 / 256 / 512 / 1024

Output (see page 28)

RS422 = RS422 compatible output with excitation 5 V DC

Connection

KAB3M = Cable, standard length 3 m

M12A8 = 8-pin socket M12

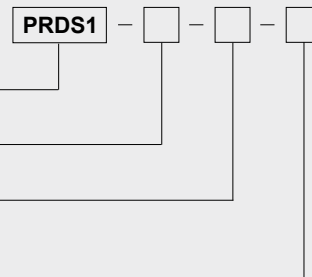

Order code position magnet (see accessories page 30)

PRMAG ...

Order code connector cable (see accessories page 33)

KAB-2M-M12/8F/G-LITZE

Order example: PRDS1 - 1024 - RS422 - M12A8

POSIROT®
PRDS1
Magnetic Angle Encoder with SSI Output

PRELIMINARY



Magnetic angle encoder 0 - 360° in M12 housing

- Protection class IP67/IP69K
- Non-contact with external position magnet
- Wear free
- All metal housing
- Synchronous serial output (SSI)

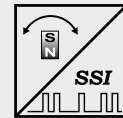

Specifications		
Output		Synchronous serial (SSI)
Resolution		12 bit f.s.
Repeatability		±0.03 % f.s. (typ.)
Linearity		±0.3 % f.s. (typ.); a misalignment of the position magnet has an effect on the linearity (see page 30)
Measurement range		0 ... 360°
Max. revolutions		30,000 r.p.m.
Code characteristics		CW, CCW
Rated distance sensor / magnet		Depending on the position magnet, see page 30
Material		Stainless steel / aluminium / zinc (depends on the model)
Mounting		M12 x 1
Protection class		IP67/IP69K (connector output with IP69K connector cable) IP67 (cable output)
Shock		EN 60068-2-27:1993, 100 g/11 ms, 100 shocks
Vibration		EN 60068-2-6:1995, 20 g 10 Hz-2 kHz, 10 cycles

Order Code PRDS1

Model name

Output (see page 29)

SSI = Synchronous serial

Code characteristics

CW = Code increasing CW

CCW = Code increasing CCW

Connection

KAB3M = Cable, standard length 3 m

M12A8 = 8 pin socket M12

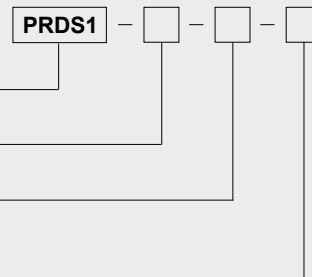

Order code position magnet (see accessories page 30)

PRMAG ...

Order code connector cable (see accessories page 33)

KAB-2M-M12/8F/G-LITZE

Order example: PRDS1 - SSI - CW - M12A8

POSIROT®
PRAS1/PRDS1
Dimensions



Outline drawing

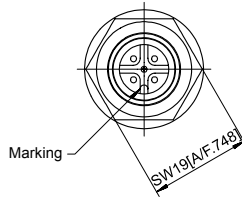
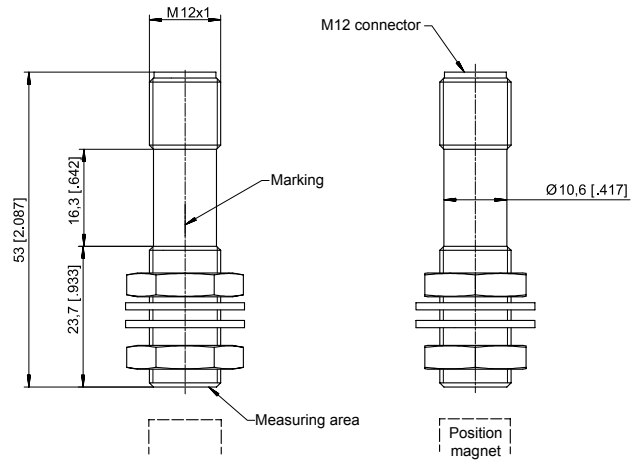

Dimensions in mm [inch]

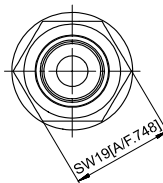
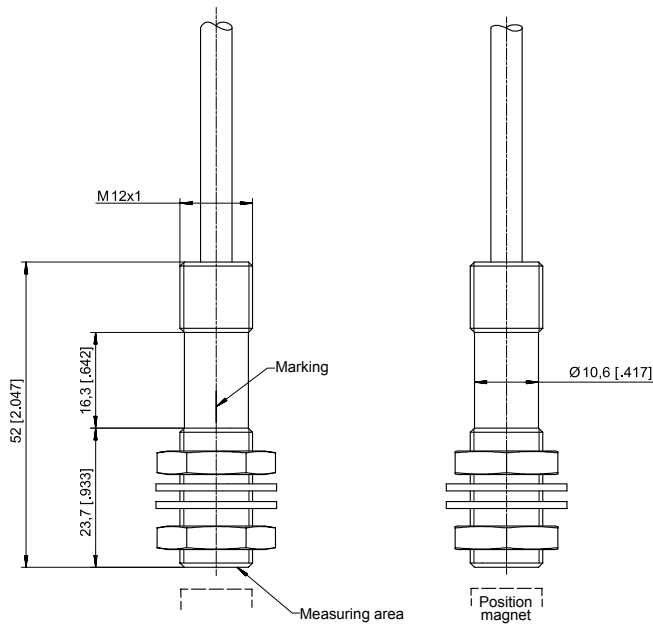

Dimensions in mm [inch]

Weight without cable 35 g approx.
 Dimensions informative only.
 For guaranteed dimensions please consult factory.

POSIROT®
PRAS2
Magnetic Angle Sensor with Analog Output



Magnetic angle sensor 0 - 360 degrees in a flat housing with 36 mm dia.

- Protection class IP67/IP69K
- Non-contact with external position magnet
- Wear free
- Flat housing – 20 mm thickness
- Outputs:
 Voltage 0.5 ... 4.5 V, 0.5 ... 10 V
 Current 4 ... 20 mA
- Redundant second channel as option

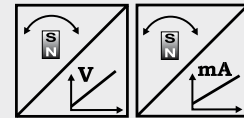

Specifications	Outputs	Voltage: 0.5 ... 4.5 V; 0.5 ... 10 V Current: 4 ... 20 mA, 3 wire
Resolution		0.03 % (60 ... 360°); 0.1 % (15 ... 45°)
Repeatability		±0.03 % (60 ... 360°); ±0.1 % (15 ... 45°)
Linearity		±0.3 % f.s. (typ.); a misalignment of the position magnet has an effect on the linearity (see page 30)
Measurement range		0 ... 15° to 0 ... 360°, standard 360°
Signal characteristics		CW, CCW
Rated distance sensor / magnet		Depending on the position magnet, see page 30
Material		Aluminium / stainless steel / zinc (depends on the model)
Mounting		Clamps, mounting plate
Protection class		IP67/IP69K (connector output with IP69K connector cable) IP67 (cable output, option IP67/IP69K)
Shock		EN 60068-2-27:1993, 100 g/11 ms, 100 shocks
Vibration		EN 60068-2-6:1995, 20 g 10 Hz-2 kHz, 10 cycles

Order Code PRAS2

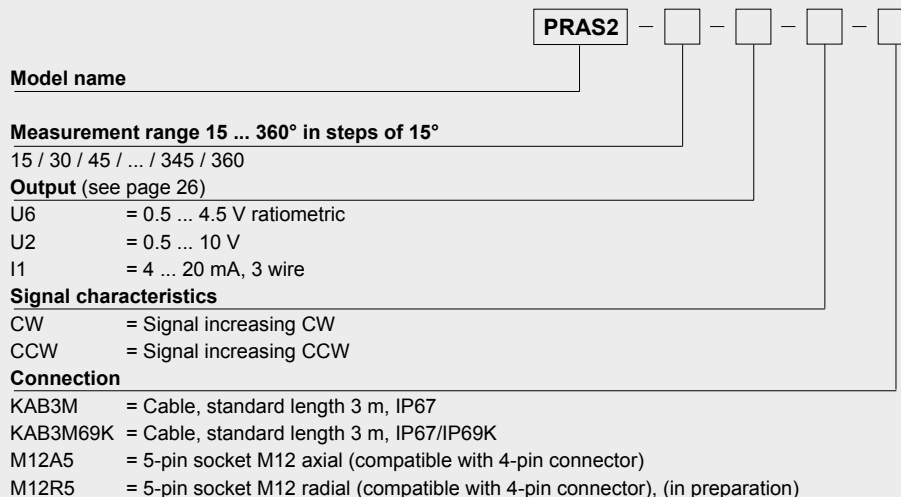

Order code mounting clamps (set of 3 pieces)

PRPT-BFS1

Order code position magnet (see accessories page 30)

PRMAG ...

Order code connector cable (see accessories page 32)

KAB-2M-M12/4F/G-LITZE

Order example: PRAS2 - 360 - I1 - CW - KAB3M

POSIROT®
PRDS2
Magnetic Angle Encoder with Incremental Output

PRELIMINARY



Magnetic angle encoder 0 - 360 degrees in a flat housing with 36 mm dia.

- Protection class IP67/IP69K
- Non-contact with external position magnet
- Wear free
- Flat housing – 20 mm thickness
- Incremental encoder output

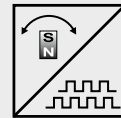

Specifications	Output	Incremental encoder outputs A, \bar{A} , B, \bar{B} , Z, \bar{Z} , RS422 compatible
Resolution	128, 256, 512, 1024 pulses per revolution	
Linearity	$\pm 1^\circ$; a misalignment of the position magnet has an effect on the linearity (see page 30)	
Measurement range	0 ... 360°	
Max. revolutions	30,000 per min	
Max. output frequency	500 kHz (the quadrature counter of the subsequent circuit must be able to process >500 kHz)	
Rated distance sensor / magnet	Depending on the position magnet, see page 30	
Material	Aluminium / stainless steel / zinc (depends on the model)	
Mounting	Clamps, mounting plate	
Protection class	IP67/IP69K (connector output with IP69K connector cable) IP67 (cable output, option IP67/IP69K)	
Shock	EN 60068-2-27:1993, 100 g/11 ms, 100 shocks	
Vibration	EN 60068-2-6:1995, 20 g 10 Hz-2 kHz, 10 cycles	

Order Code PRDS2

Model name

Resolution (pulses/revolution)

128 / 256 / 512 / 1024

Output (see page 28)

RS422 = RS422 compatible output with excitation 5 V DC

Connection

KAB3M = Cable, standard length 3 m, IP67

KAB3M69K = Cable, standard length 3 m, IP67/IP69K

M12A8 = 8-pin socket M12 axial

M12R8 = 8-pin socket M12 radial (in preparation)

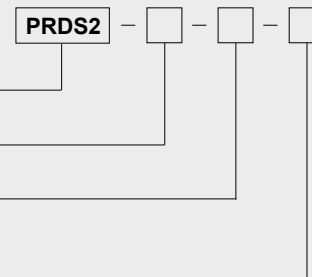

Order code mounting clamps (set of 3 pieces)

PRPT-BFS1

Order code position magnet (see accessories page 30)

PRMAG ...

Order code connector cable (see accessories page 33)

KAB-2M-M12/8F/G-LITZE

Order example: PRDS2 - 1024 - RS422 - KAB3M

POSIROT®
PRDS2
Magnetic Angle Encoder with SSI Output

PRELIMINARY



Magnetic angle encoder 0 - 360 degrees in a flat housing with 36 mm dia.

- Protection class IP67/IP69K
- Non-contact with external position magnet
- Wear free
- Flat housing – 20 mm thickness
- Synchronous serial output (SSI)

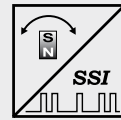

Specifications		
Output		Synchronous serial (SSI)
Resolution		12 bit f.s.
Repeatability		±0.03 % f.s. (typ.)
Linearity		±0.3 % f.s. (typ.); a misalignment of the position magnet has an effect on the linearity (see page 30)
Measurement range		0 ... 360°
Max. revolutions		30,000 r.p.m.
Code characteristics		CW, CCW
Rated distance sensor / magnet		Depending on the position magnet, see page 30
Material		Aluminium / stainless steel / zinc (depends on the model)
Mounting		Clamps, mounting plate
Protection class		IP67/IP69K (connector output with IP69K connector cable) IP67 (cable output, option IP67/IP69K)
Shock		EN 60068-2-27:1993, 100 g/11 ms, 100 shocks
Vibration		EN 60068-2-6:1995, 20 g 10 Hz-2 kHz, 10 cycles

Order Code PRDS2

Model name

Output (see page 29)

SSI = Synchronous serial

Code characteristics

CW = Code increasing CW

CCW = Code increasing CCW

Connection

KAB3M = Cable, standard length 3 m, IP67

KAB3M69K = Cable, standard length 3 m, IP67/IP69K

M12A8 = 8-pin socket M12 axial

M12R8 = 8-pin socket M12 radial (in preparation)

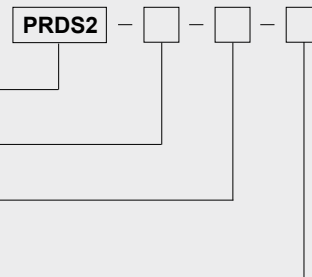

Order code mounting clamps (set of 3 pieces)

PRPT-BFS1

Order code position magnet (see accessories page 30)

PRMAG ...

Order code connector cable (see accessories page 33)

KAB-2M-M12/8F/G-LITZE

Order example: PRDS2 - SSI - CW - KAB3M

POSIROT®
PRAS2/PRDS2
Dimensions



Outline drawing
sensor with cable
output

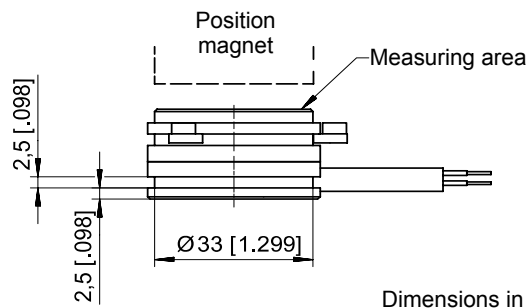
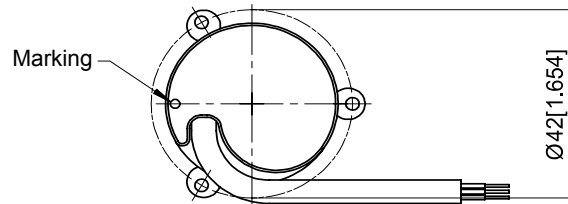
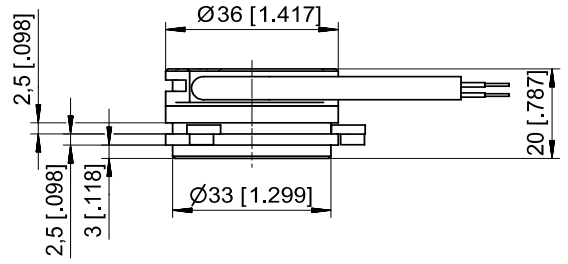

Weight without cable approx. 40 g.
Dimensions informative only.
For guaranteed dimensions please consult factory.

POSIROT® PRAS2/PRDS2 Dimensions



Outline drawing sensor M12 axial

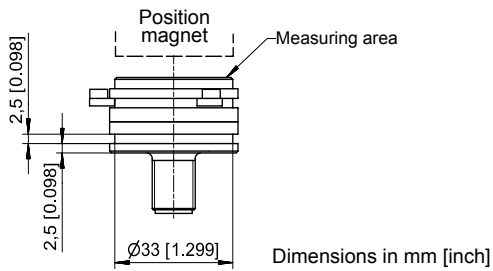
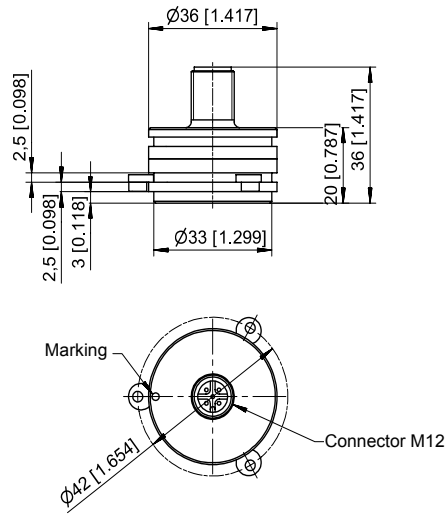

Weight without cable approx. 50 g.
Dimensions informative only.
For guaranteed dimensions please consult factory.

POSIROT® PRAS2/PRDS2 Dimensions



Outline drawing sensor M12 radial

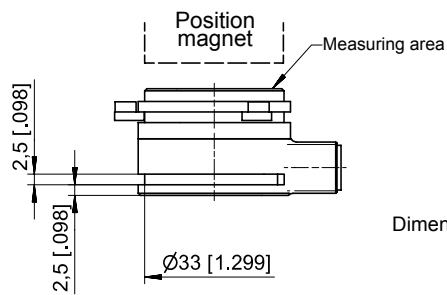
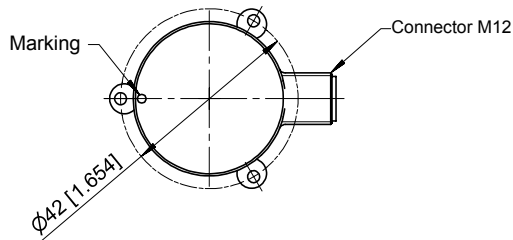
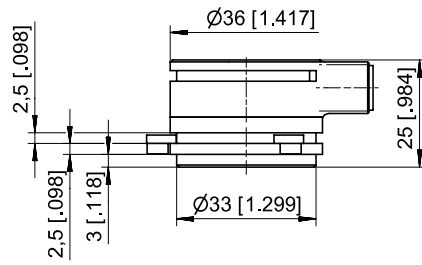

Dimensions in mm [inch]

Ask factory for availability

Weight without cable approx. 50 g.

Dimensions informative only.

For guaranteed dimensions please consult factory.

POSIROT®
PRAS20 / 21
Magnetic Angle Sensor with Analog Output

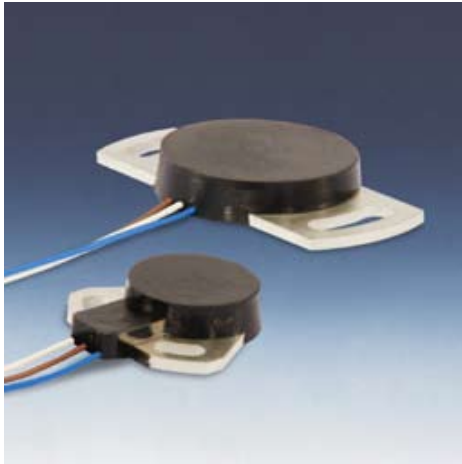

Magnetic angle sensor 0 - 360°

- Protection class IP60
- Non-contact with external position magnet
- Wear free
- Compact, low profile housing
- Output:
Voltage 0.5 ... 4.5 V
- Other outputs available on request

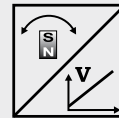

Specifications	Outputs	Voltage: 0.5 ... 4.5 V
	Resolution	0.03 % (60 ... 360); 0.1 % (15 ... 45°)
	Repeatability	±0.03 % (60 ... 360°); ±0.1 % (15 ... 45°)
	Linearity	±0.5 % f.s. (typ.); a misalignment of the position magnet has an effect on the linearity (see page 30)
	Measurement range	0 ... 15° to 0 ... 360°, standard 360°
	Signal characteristics	CW, CCW
	Rated distance sensor / magnet	Depending on the position magnet, see page 30
	Material	Epoxy glass fiber, thermoplastic
	Mounting	Screws M3 resp. M4
	Connection	
	Protection class	IP60
	Shock	EN 60068-2-27:1993, 100 g/11 ms, 100 shocks
	Vibration	EN 60068-2-6:1995, 20 g 10 Hz-2 kHz, 10 cycles

Order Code PRAS20 / 21

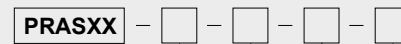

Model name

PRAS20
 PRAS21

Measurement range 15 ... 360° in steps of 15°

15 / 30 / 45 / ... / 345 / 360

Output (see page 26)

U6 = 0.5 ... 4.5 V ratiometric

Signal characteristics

CW = Signal increasing CW
 CCW = Signal increasing CCW

Connection

A300 = Single wire ETFE 3 x 0.5 mm², length 300 mm

Order example: PRAS20 - 360 - U6 - CW - A300

POSIROT®
PRDS20 / 21
Magnetic Angle Encoder with Incremental Output



Outline drawing
PRAS20

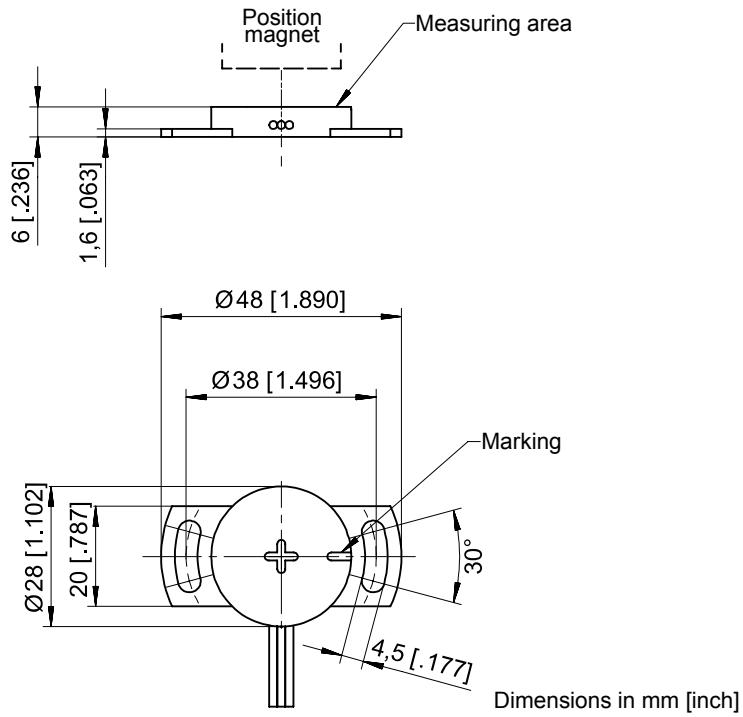

Weight without cable approx. 8 g.
 Dimensions informative only.
 For guaranteed dimensions please consult factory.

Outline drawing
PRAS21

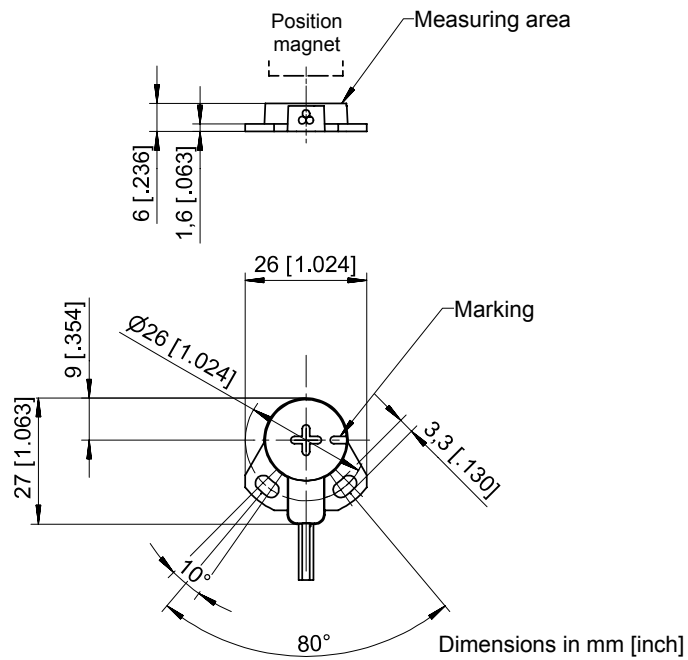

Weight without cable approx. 5 g.
 Dimensions informative only.
 For guaranteed dimensions please consult factory.

POSIROT®
PRAS3
Magnetic Angle Sensor with Analog Output



Magnetic angle sensor 0 - 360 degrees in a 36 mm dia. housing

- With 10 mm shaft or 6 mm hollow shaft
- Protection class IP67/IP69K
- Magnetic measurement principle
- Outputs:
 Voltage 0.5 ... 4.5 V, 0.5 ... 10 V
 Current 4 ... 20 mA
- Redundant second channel as option

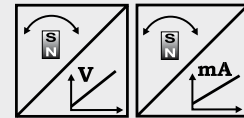

Specifications	Outputs	Voltage: 0.5 ... 4.5 V; 0.5 ... 10 V Current: 4 ... 20 mA, 3 wire
	Resolution	0.03 % (60 ... 360°); 0.1 % (15 ... 45°)
	Repeatability	±0.03 % (60 ... 360°); ±0.1 % (15 ... 45°)
	Linearity	±0.3 % f.s. (typ.)
	Measurement range	0 ... 15° to 0 ... 360°, standard 360°
	Signal characteristics	CW, CCW
	Material	Stainless steel / aluminium / zinc (depends on the model)
	Mounting	Clamps, mounting plate
	Protection class	IP67 (IP67/IP69K option, housing)
	Shock	EN 60068-2-27:1993, 100 g/11 ms, 100 shocks
	Vibration	EN 60068-2-6:1995, 20 g 10 Hz-2 kHz, 10 cycles
	Life cycle of bearings	100 x 10 ⁶ revolutions (<1500 r.p.m.)
	Revolutions per minute	Max. 10,000 r.p.m.
	Allowable shaft load	100 N radial, 100 N axial

Order Code PRAS3

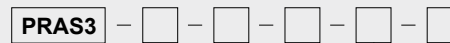

Model name

Shaft

V = 10 mm shaft

H = 6 mm hollow shaft

Measurement range 15 ... 360° in steps of 15°

15 / 30 / 45 / ... / 345 / 360

Output (see page 26)

U6 = 0.5 ... 4.5 V ratiometric

U2 = 0.5 ... 10 V

I1 = 4 ... 20 mA, 3 wire

Signal characteristics

CW = Signal increasing CW

CCW = Signal increasing CCW

Connection

KAB3M = Cable, standard length 3 m, IP67

KAB3M69K = Cable, standard length 3 m, IP67/IP69K

M12A5 = 5-pin socket M12 axial (compatible with 4-pin connector)

M12R5 = 5-pin socket M12 radial (compatible with 4-pin connector), (in preparation)

Order code mounting clamps (set of 3 pieces)

PRPT-BFS1

Order code connector cable (see accessories page 32)

KAB-2M-M12/4F/G-LITZE

Order example: PRAS3 - V - 360 - I1 - CW - KAB3M



Magnetic angle encoder 0 - 360 degrees in a 36 mm dia. housing

- With 10 mm shaft or 6 mm hollow shaft
- Protection class IP67/IP69K
- Magnetic measurement principle
- Incremental encoder output

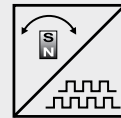

Specifications	Output	Incremental encoder outputs A, \bar{A} , B, \bar{B} , Z, \bar{Z} , RS422 compatible
	Resolution	128, 256, 512, 1024 pulses per revolution
	Linearity	$\pm 1^\circ$
	Measurement range	0 ... 360°
	Max. output frequency	500 kHz (the quadrature counter of the subsequent circuit must be able to process >500 kHz)
	Material	Stainless steel / aluminium / zinc (depends on the model)
	Mounting	Clamps, mounting plate
	Protection class	IP67 (IP67/IP69K option, housing)
	Shock	EN 60068-2-27:1993, 100 g/11 ms, 100 shocks
	Vibration	EN 60068-2-6:1995, 20 g 10 Hz-2 kHz, 10 cycles
	Life cycle of bearings	100 x 10 ⁶ revolutions (<1500 r.p.m.)
	Revolutions per minute	Max. 10,000 r.p.m.
	Allowable shaft load	100 N radial, 100 N axial

Order Code PRDS3

PRDS3 - [] - [] - [] - []

Model name

Shaft

- V = 10 mm shaft
- H = 6 mm hollow shaft

Resolution (pulses/revolution)

128 / 256 / 512 / 1024

Output (see page 28)

RS422 = RS422 compatible output with excitation 5 V DC

Connection

- KAB3M = Cable, standard length 3 m, IP67
- KAB3M69K = Cable, standard length 3 m, IP67/IP69K
- M12A8 = 8-pin socket M12 axial
- M12R8 = 8-pin socket M12 radial (in preparation)

Order code mounting clamps (set of 3 pieces)

PRPT-BFS1

Order code connector cable (see accessories page 33)

KAB-2M-M12/8F/G-LITZE

Order example: PRDS3 - V - 1024 - RS422 - KAB3M

POSIROT®
PRDS3
Magnetic Angle Encoder with SSI Output

PRELIMINARY



Magnetic angle encoder 0 - 360 degrees in a 36 mm dia. housing

- With 10 mm shaft or 6 mm hollow shaft
- Protection class IP67/IP69K
- Magnetic measurement principle
- Synchronous serial output (SSI)

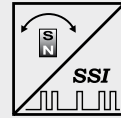

Specifications		
	Output	Synchronous serial (SSI)
	Resolution	12 bit f.s.
	Repeatability	±0.03 % f.s. (typ.)
	Linearity	±0.3 % f.s. (typ.)
	Measurement range	0 ... 360°
	Code characteristics	CW, CCW
	Material	Stainless steel / aluminium / zinc (depends on the model)
	Mounting	Clamps, mounting plate
	Protection class	IP67 (IP67/IP69K option, housing)
	Shock	EN 60068-2-27:1993, 100 g/11 ms, 100 shocks
	Vibration	EN 60068-2-6:1995, 20 g 10 Hz-2 kHz, 10 cycles
	Life cycle of bearings	100 x 10 ⁶ revolutions (<1500 r.p.m.)
	Revolutions per minute	Max. 10,000 r.p.m.
	Allowable shaft load	100 N radial, 100 N axial

Order Code PRDS3

PRDS3 - [] - [] - [] - []

Model name

Shaft

- V = 10 mm shaft
- H = 6 mm hollow shaft

Output (see page 29)

- SSI = Synchronous serial

Code characteristics

- CW = Code increasing CW
- CCW = Code increasing CCW

Connection

- KAB3M = Cable, standard length 3 m, IP67
- KAB3M69K = Cable, standard length 3 m, IP67/IP69K
- M12A8 = 8-pin socket M12 axial
- M12R8 = 8-pin socket M12 radial (in preparation)

Order code mounting clamps (set of 3 pieces)

PRPT-BFS1

Order code connector cable (see accessories page 33)

KAB-2M-M12/8F/G-LITZE

Order example: PRDS3 - V - SSI - CW - KAB3M

POSIROT®
PRAS3/PRDS3
Dimensions



Outline drawing sensor with shaft

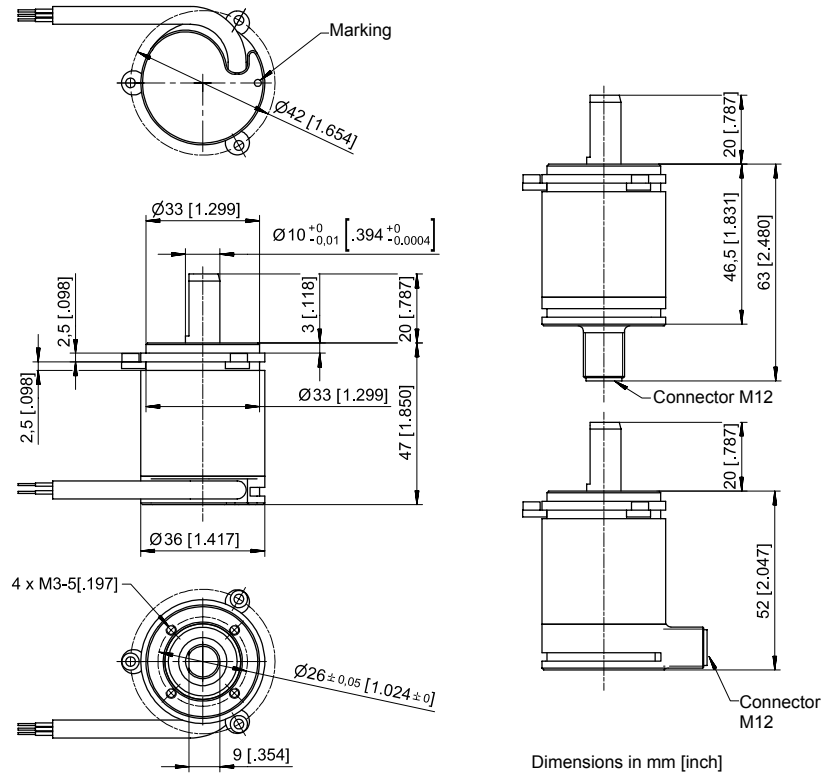

Outline drawing sensor with hollow shaft

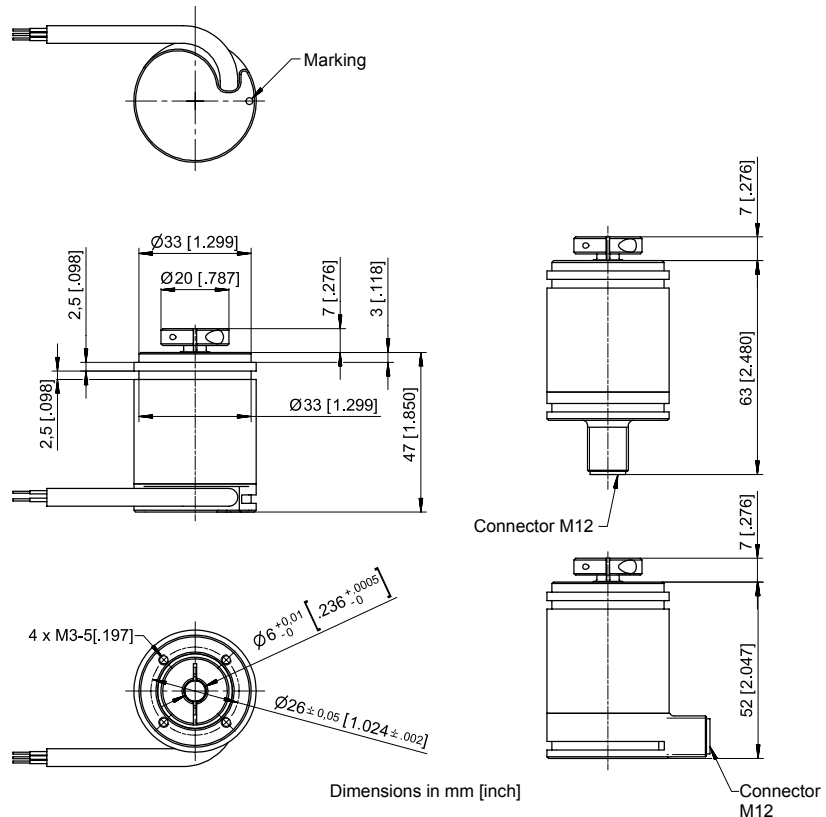

Weight without cable 250 g approx.
 Dimensions informative only.
 For guaranteed dimensions please consult factory.

POSIROT®
PRAS4
Magnetic angle sensor with analog output



Magnetic angle sensor 0 - 360° in a flat housing with 79 mm diameter

- With 13 mm shaft or non-contact
- Protection class IP67/IP69K
- Magnetic measurement principle
- Outputs:
 Voltage 0.5 ... 4.5 V; 0.5 ... 10 V
 Current 4 ... 20 mA
- Other outputs available on request

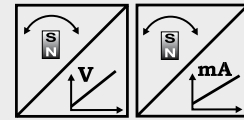

Specifications	Outputs	Voltage: 0.5 ... 4.5 V; 0.5 ... 10 V Current: 4 ... 20 mA, 3 wire
	Resolution	0.03 % (60 ... 360°); 0.1 % (15 ... 45°)
	Repeatability	±0.03 % (60 ... 360°); ±0.1 % (15 ... 45°)
	Linearity	±0.3 % f.s. (typ.); a misalignment of the position magnet has an effect on the linearity (see page 30)
	Measurement range	0 ... 15° to 0 ... 360°, standard 360°
	Signal characteristics	CW, CCW
	Material	Stainless steel / aluminium / zinc (depends on the model)
	Mounting	Screws M6 or M5
	Protection class	IP67/IP69K housing (with IP69K connector cable)
	Shock	EN 60068-2-27:1993, 100 g/11 ms, 100 shocks
Vibration	EN 60068-2-6:1995, 20 g 10 Hz-2 kHz, 10 cycles	
Life cycle of bearings	100 x 10 ⁶ revolutions (<1500 r.p.m.)	
Revolutions per minute	Max. 10,000 r.p.m.	
Allowable shaft load	120 N radial, 120 N axial	

Order Code PRAS4

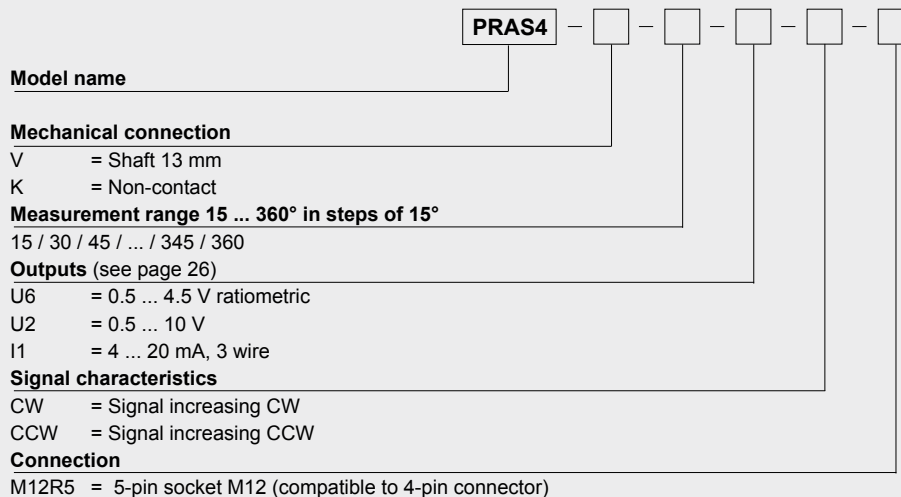

Order code position magnet (see accessories page 30)

PRMAG2

Order code connector cable (see accessories page 32)

KAB-2M-M12/4F/G-LITZE

Order example: PRAS4 - V - 360 - I1 - CW - M12R5

**Outline drawing
 sensor with shaft**

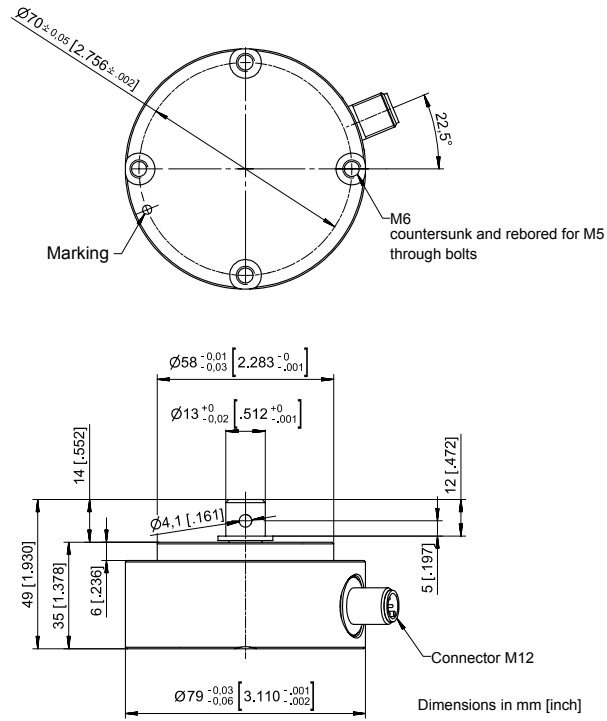

**Outline drawing
 sensor non-contact**

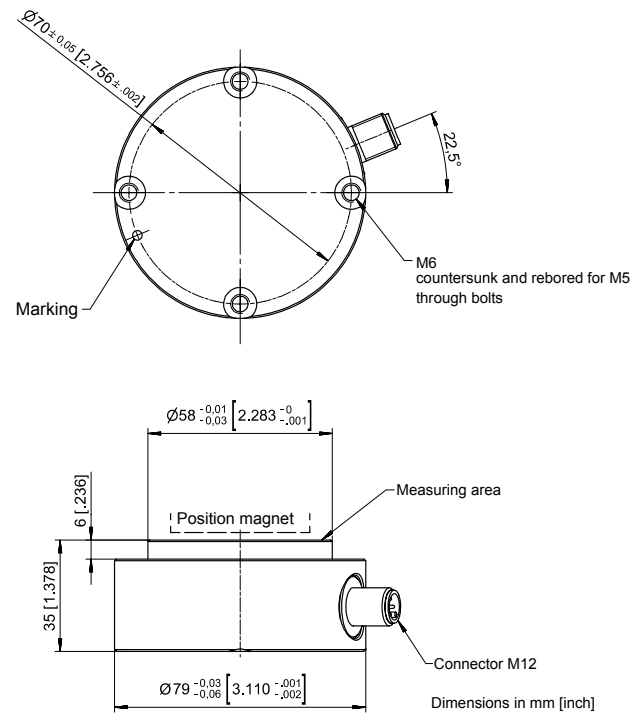

Weight without cable 450 g approx.
 Dimensions informative only.
 For guaranteed dimensions please consult factory.

POSITILT®
PTAS2
Magnetic inclination sensor with analog output



Magnetic inclination sensor in a 36 mm housing

- Protection class IP67/IP69K
- Magnetic measurement principle
- Outputs:
 Voltage 0.5 ... 4.5 V; 0.5 ... 10 V
 Current 4 ... 20 mA
- Redundant second channel as option
- Other outputs available on request

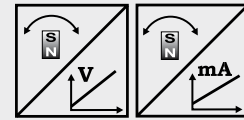

Specifications	Outputs	Voltage: 0.5 ... 4.5 V; 0.5 ... 10 V Current: 4 ... 20 mA, 3 wire
	Resolution	0.03 % ($\pm 30 \dots \pm 180$); 0.1 % ($\pm 15^\circ$)
	Repeatability	± 0.03 % ($\pm 30 \dots \pm 180^\circ$); ± 0.1 % (± 15)
	Linearity	± 0.3 % f.s. (typ.)
	Measurement range	0 ... $\pm 15^\circ$ to 0 ... $\pm 180^\circ$, standard $\pm 180^\circ$
	Signal characteristics	CW, CCW
	Material	Stainless steel / aluminium / zinc (depends on the model)
	Mounting	Clamps, mounting plate
	Protection class	IP67 (IP67/IP69K option)
	Shock	EN 60068-2-27:1993, 100 g/11 ms, 100 shocks
Vibration	EN 60068-2-6:1995, 20 g 10 Hz-2 kHz, 10 cycles	

Order Code PTAS2

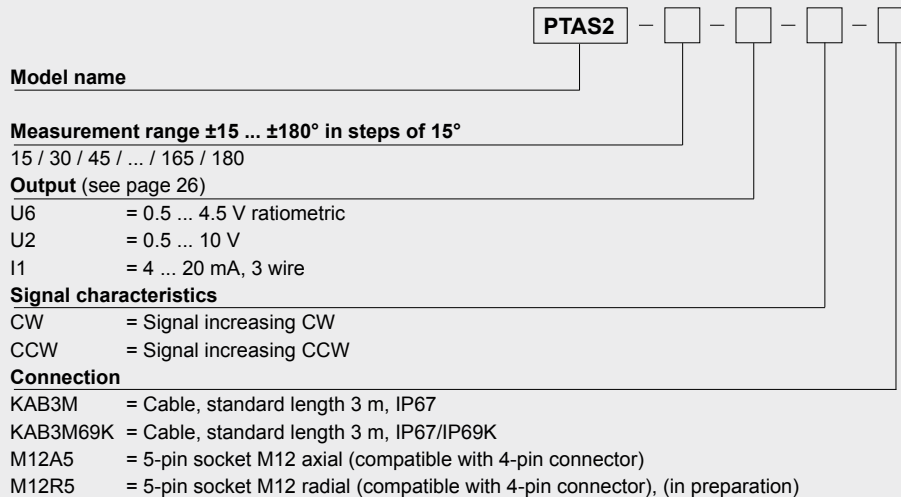

Order code mounting clamps (set of 3 pieces)

PRPT-BFS1

Order code connector cable (see accessories page 32)

KAB-2M-M12/4F/G-LITZE

Order example: PTAS2 - 180 - I1 - CW - KAB3M

**Outline drawing
 sensor**

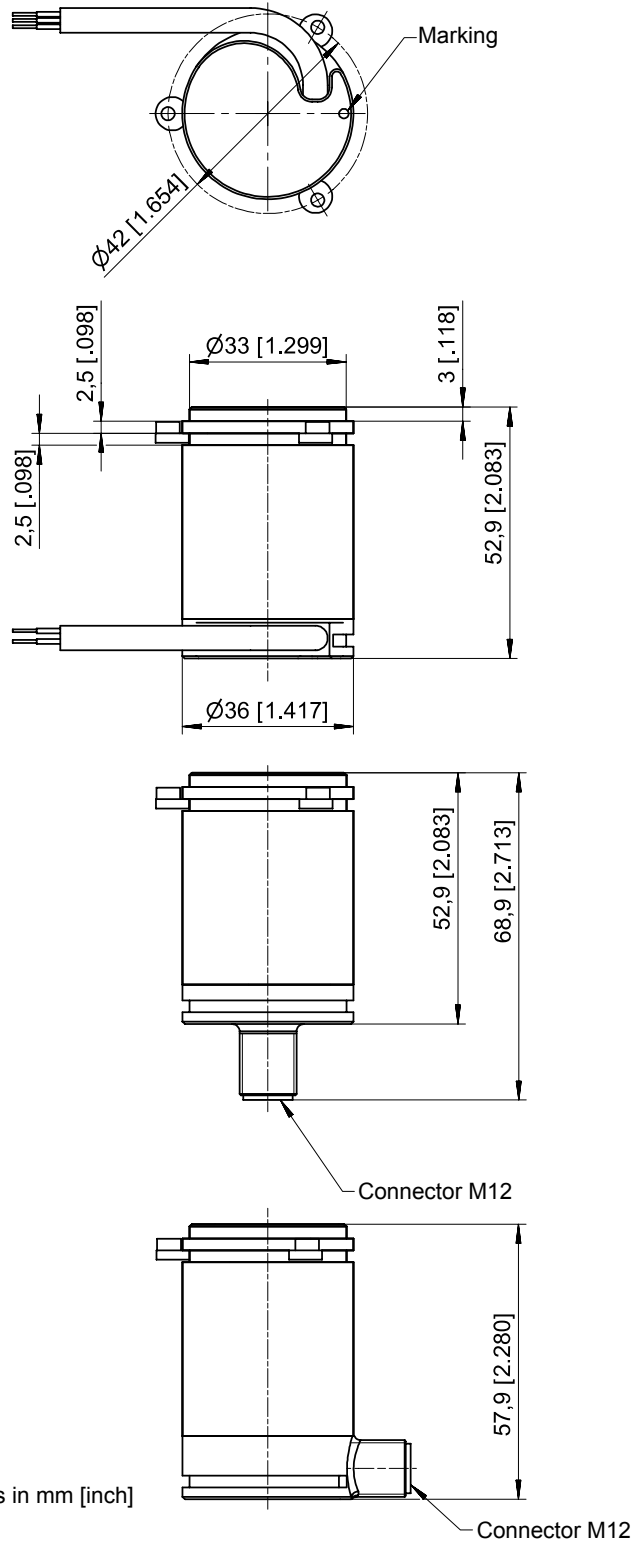

Dimensions in mm [inch]

Dimensions informative only.
 For guaranteed dimensions please consult factory.

POSIROT[®] – PRAS, POSITILT[®] – PTAS

Outputs U2, U6 and I1

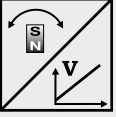
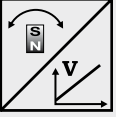
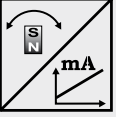

U2 Voltage Output 0.5 ... 10 V 	Excitation voltage	+18 ... +27 V DC (+36 V DC as option)
	Excitation current	40 mA max.
	Output voltage	0.5 ... 10 V DC
	Output current	2 mA max.
	Output load	> 5 kΩ
	Measuring rate	1 kHz standard
	Stability (temperature)	±50 x 10 ⁻⁶ / °C f.s. (typ.) for 90°...360° ±100 x 10 ⁻⁶ / °C f.s. (typ.) for <90°
	Operating temperature	-40 ... +85 °C (+105 °C as option, for sensors w/o shaft only)
	Protection	Reverse polarity, short circuit
	EMC	According to EN 61326:2004
U6 = U6/5 / U6/8,25 Voltage Output 10 ... 90 % ratiometric 	Excitation voltage	+5V DC ±10 % / +8.25 V DC ±10 %
	Excitation current	40 mA max.
	Output voltage	10 ... 90 % of the excitation voltage
	Output current	2 mA max.
	Output load	> 1 kΩ
	Measuring rate	1 kHz standard
	Stability (temperature)	±50 x 10 ⁻⁶ / °C f.s. (typ.) for 90°...360° ±100 x 10 ⁻⁶ / °C f.s. (typ.) for <90°
	Operating temperature	-40 ... +85 °C (+105 °C as option, for sensors w/o shaft only)
	Protection	Reverse polarity, short circuit
	EMC	According to EN 61326:2004
I1 Current Output 4 ... 20 mA 	Excitation voltage	+18 ... +27 V DC (+36 V DC as option)
	Excitation current	60 mA max.
	Load resistor	500 Ω max.
	Output current	4 ... 20 mA
	Measuring rate	1 kHz standard
	Stability (temperature)	±50 x 10 ⁻⁶ / °C f.s. (typ.) for 90°...360° ±100 x 10 ⁻⁶ / °C f.s. (typ.) for <90°
	Operating temperature	-40 ... +85 °C
	Protection	Reverse polarity, short circuit
	EMC	According to EN 61326:2004

Other outputs available on request.

Output signals

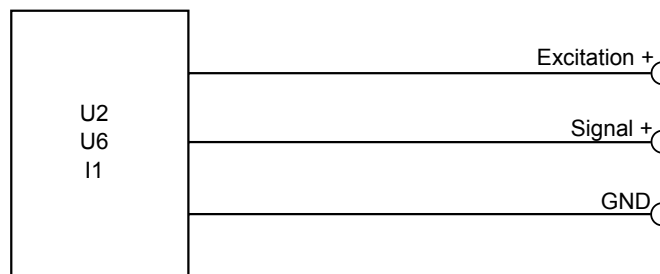
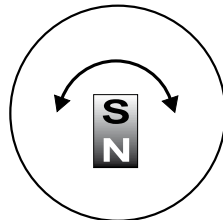

Signal Wiring	Output signals	Connector pin	Cable color
	Excitation +	1	brown
	Signal	2	white
	GND	3	blue
	Do not connect!	4	black
	Do not connect!	5	-

Connection

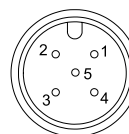

View to sensor connector

M12A5 / M12R5

POSIROT[®]

Characteristics for magnetic angle sensors



Output signal
(CW increasing)

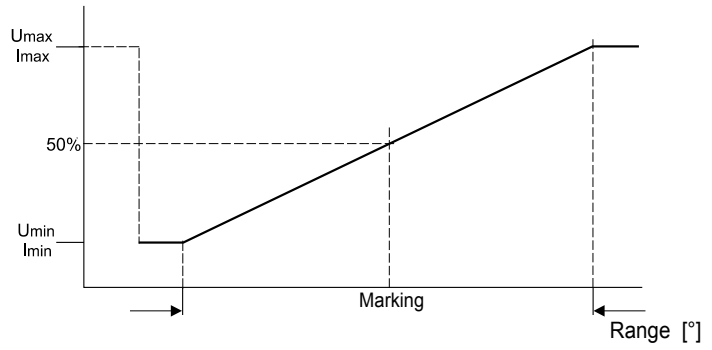

Output signal
(CCW increasing)

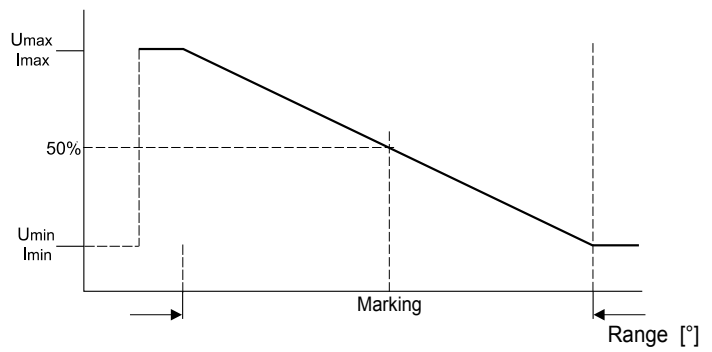

Example angular range 90°

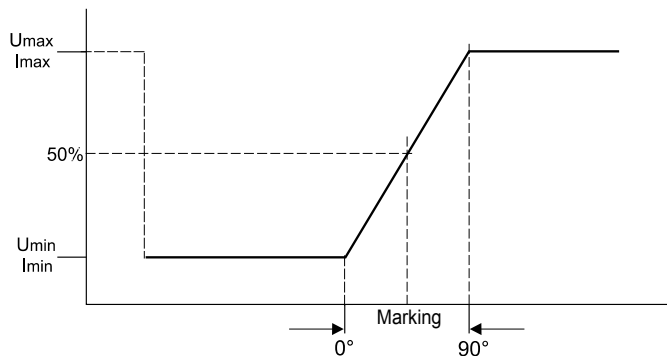

Example angular range 360°

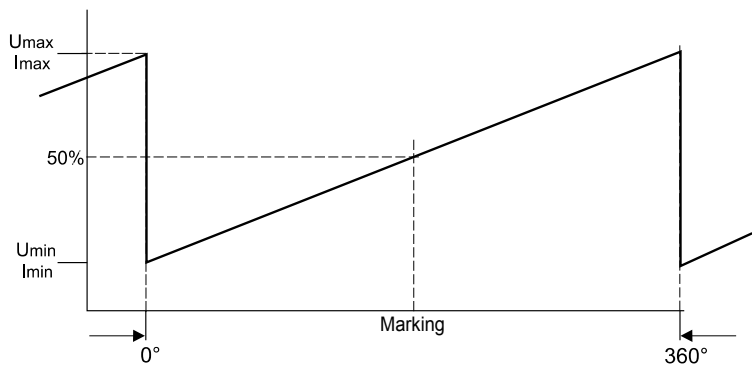

RS422 Incremental 	Interface	EIA RS-422
	Excitation voltage	5 V DC $\pm 10\%$
	Excitation current	100 mA max., depending on the load
	Pulse frequency	<500 kHz
	Output signals	A, \bar{A} , B, \bar{B} , Z, \bar{Z} Push-Pull
	Output current	10 mA max.
	Stability (temperature)	$\pm 50 \times 10^{-6}$ / °C f.s. (typ.)
	Operating temperature	-40 ... +85 °C
	Protection	Short circuit
	EMC	According to EN 61326:2004

Output signals

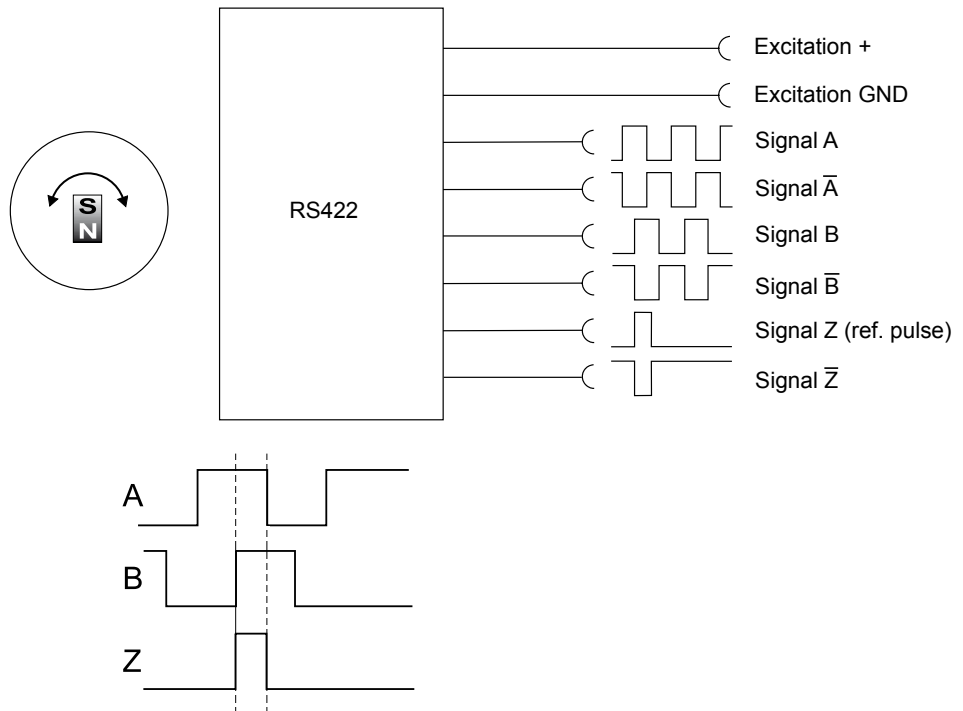

Signal wiring	Output signals	Connector pin	Cable color
	Excitation +	1	white
	GND	2	brown
	A	4	green
	\bar{A}	6	yellow
	B	3	grey
	\bar{B}	5	pink
	Z	7	blue
	\bar{Z}	8	red

Connection



View to sensor connector

M12A8 / M12R8

POSIROT® – PRDS

Output SSI

PRELIMINARY



SSI Synchronous serial 	Interface	EIA RS-422
	Excitation voltage	5 V DC $\pm 10\%$
	Excitation current	100 mA max. without load
	Clock frequency	100 kHz ... 1 MHz
	Code	Single step Gray code 12 Bit
	Resolution	12 Bit
	Delay between pulse trains	20 μ s min.
	Stability (temperature)	$\pm 50 \times 10^{-6}$ / °C f.s. (typ.)
	Operating temperature	-40 ... +85 °C
	Protection	Short circuit
EMC	According to EN 50082-2, EN50081-1	

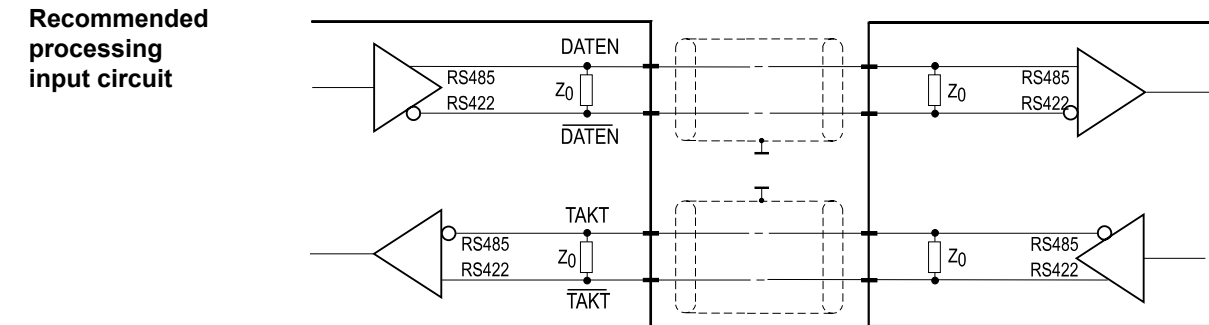
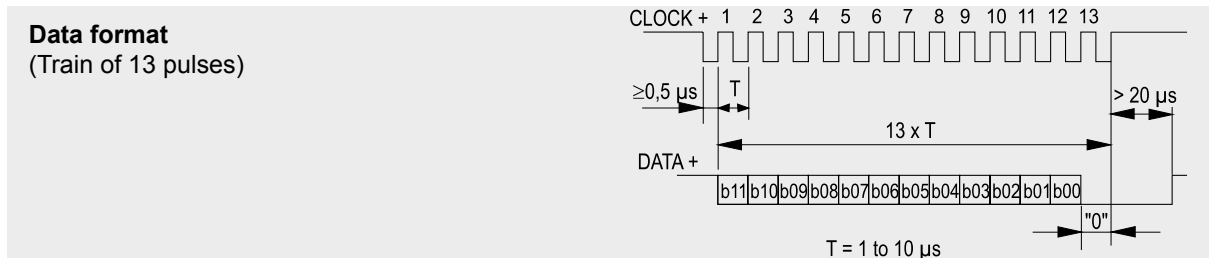

Cable length	Baud rate
50 m	100-1000 kHz
100 m	100-300 kHz

Note:
Extension of the cable length will reduce the maximum transmission rate. The signals CLOCK /CLOCK and DATA/DATA must be connected in a twisted pair cable, shielded per pair and common.

Signal wiring	Signal name	Connector pin no.	Cable color
	Excitation +	1	white
	Excitation GND	2	brown
	CLOCK	3	green
	<u>CLOCK</u>	4	yellow
	DATA	5	grey
	<u>DATA</u>	6	pink

Connection



View to sensor connector

M12A8 / M12R8

PRMAG1

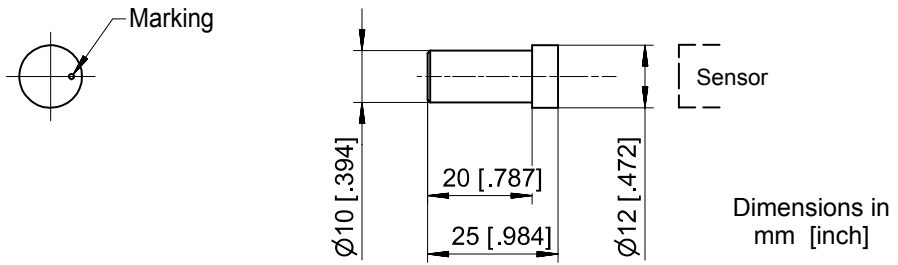

Weight 10 g approx., moment of inertia 0.1 kgmm²

PRMAG2

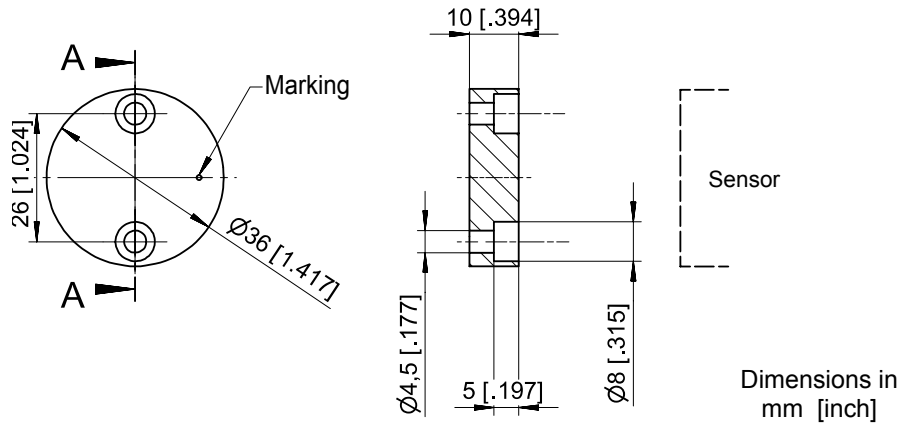

Weight 30 g approx., moment of inertia 4.5 kgmm²

Dimensions informative only
 For guaranteed dimensions please consult factory

Note: Sensor and position magnet must be mounted aligned!

Measuring error by misalignment	Position magnet	Air gap [mm]	Parallelism [degree]	Error by axial misalignment [% f.s.]			
				0.2 mm	0.5 mm	1 mm	2 mm
	PRMAG1	0 ... 1.5	<1	0.1 %	0.3 %	1.1 %	–
PRMAG2	0 ... 4	<1	0.1 %	0.1 %	0.3 %	0.5 %	

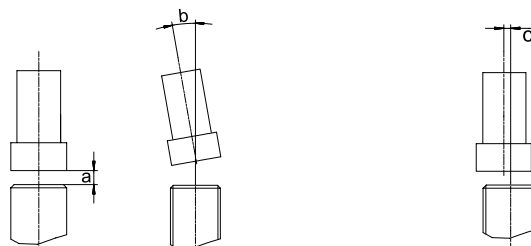

PRPT-BPL1

(screw mounting)
 For PRAS2, PRDS2,
 PRAS3, PRDS3, PTAS2

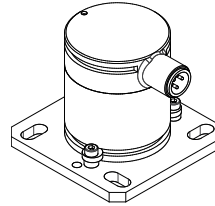
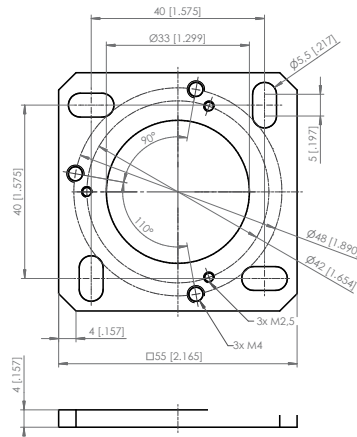

In combination with the
 mounting clamps
 PRPT-BFS1.

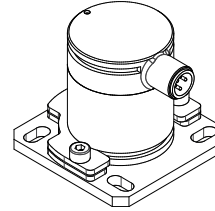

In combination with the
 mounting brackets
 PRPT-BFS2.

PRPT-BPL2

(welding assembly)
 For PRAS2, PRDS2,
 PRAS3, PRDS3, PTAS2

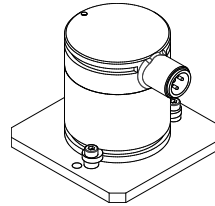
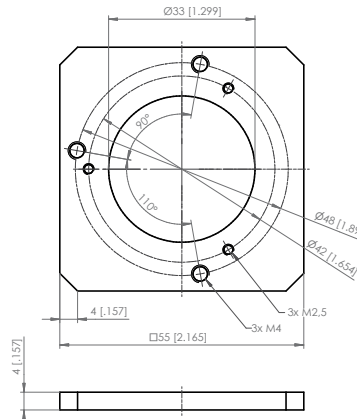

In combination with the
 mounting clamps
 PRPT-BFS1.

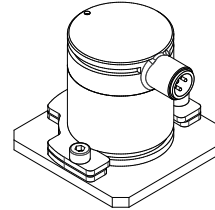

In combination with the
 mounting brackets
 PRPT-BFS2.

PRPT-BPL3

For PRAS3, PRDS3

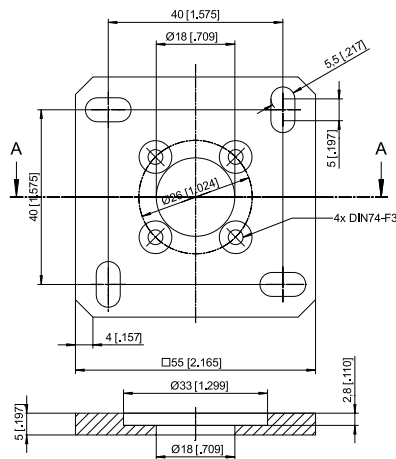

Dimensions in mm [inch]

Weight 30 g approx.
 Dimensions informative only.
 For guaranteed dimensions please consult factory.

POSIROT® Accessories Connector Cables



Connector cable for POSIROT® angle sensors 4 pins M12

Suitable for 5-pin sensor connectors M12A5 and M12R5

The 4-core screened cable is supplied with a mating 4-pin 90° M12 connector at one end and 4 wires at the other end. Available lengths are 2, 5 and 10 m.

Order code:

KAB - XM - M12/4F/W - LITZE

IP69K: **KAB - XM - M12/4F/W/69K - LITZE**

Length in m

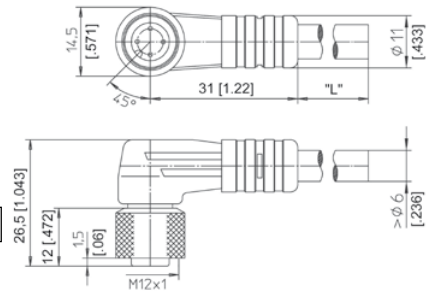

Connector cable for POSIROT® angle sensors 4 pins M12

Suitable for 5-pin sensor connectors M12A5 and M12R5

The 4-core screened cable is supplied with a mating 4-pin M12 connector at one end and 4 wires at the other end. Available lengths are 2, 5 and 10 m.

Order code:

KAB - XM - M12/4F/G - LITZE

IP69K: **KAB - XM - M12/4F/G/69K - LITZE**

Length in m

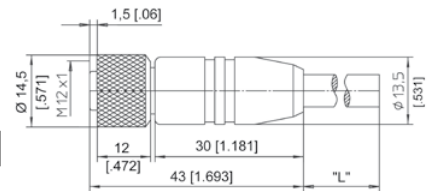

Signal wiring M12, 4 pin	Connector pin / cable color			
	1	2	3	4
	Brown	White	Blue	Black

POSIROT® Accessories Connector Cables



Connector cable for POSIROT® angle sensors 8 pins M12

The 8-core screened cable is supplied with a mating 8-pin 90° M12 connector at one end and 8 wires at the other end. Available lengths are 2, 5 and 10 m.

Order code:

KAB - XM - M12/8F/W - LITZE

IP69K: **KAB - XM - M12/8F/W/69K - LITZE**

Length in m

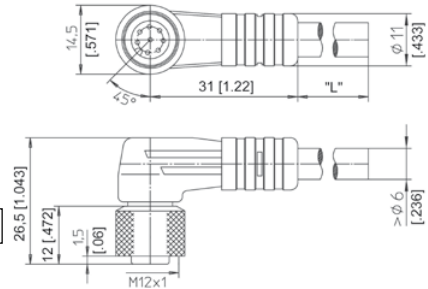

Connector cable for POSIROT® angle sensors 8 pins M12

The 8-core screened cable is supplied with a mating 8-pin M12 connector at one end and 8 wires at the other end. Available lengths are 2, 5 and 10 m.

Order code:

KAB - XM - M12/8F/G - LITZE

IP69K: **KAB - XM - M12/8F/G/69K - LITZE**

Length in m

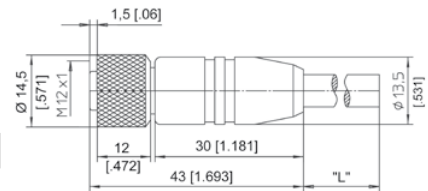

Signal wiring M12, 8 pin	Connector pin / cable color							
	1	2	3	4	5	6	7	8
	White	Brown	Green	Yellow	Grey	Pink	Blue	Red

POSIROT®
PMIS4, PMIR4
Magnetic incremental encoder



Magnetic wheels for rotative applications with POSIROT® position sensor PMIS4

- All metal housing
- Protection class IP67
- Highest EMC protection
- Large guiding distance of ± 1 mm
- Suitable for harsh environments
- Up to 184,320 pulses/360°

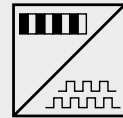

Order Code PMIR4
(magnetic wheel)

PMIR4 - [] - [] - [] - []

Model name _____

Magnetic period
20 = 2 mm

Number of Poles
50 / 64 / 90 (other pole numbers on request)

Z signal mark
O = without / M = with

Inner diameter
20 = 20H7 (other diameters on request)

Order Code PMIS4
(sensor head)

PMIS4 - [] - [] - [] **KHZ** - [] - [] - [] **M** - []

Model name _____

Magnetic period
20 = 2 mm

Scaling factor
See table page 37

Maximum pulse frequency (in kHz, standard 50 kHz)
50 / 20 / 10 (other frequencies on request, max. 480 kHz)

Output
HTL = HTL output with excitation 24 V DC, output 24 V
TTL = TTL output with excitation 5 V DC, output TTL/RS-422
TTL24V = TTL output with excitation 24 V DC, output TTL/10 mA

Signal Z / status signal
Z0 = A/B w/o signal Z
Z1 = A/B with signal Z
Z3 = A/B with signal Z and status signal, only for non-differential (single-ended) outputs

Cable length (in m, standard 2 m) _____

Connection
S = Open cable end
P15 = SUB-D connector at the cable end, 15 poles

Order example magnetic wheel: PMIR4 - 20 - 50 - O - 20

Order example sensor: PMIS4 - 20 - 100 - 50KHZ - HTL - Z0 - 2M - S

POSIROT®
PMIS4
Magnetic incremental encoder



Specifications	Output	Incremental encoder output A/B with differential push-pull output, TTL/24 V-, TTL/RS-422- or HTL-compatible	
	Excitation voltage	10 ... 30 V DC or 5 V DC ±5 %	
	Excitation current	50 mA to 300 mA, depending on pulse frequency, cable length and load	
	Magnetic period of the sensor	2 mm	5 mm
	Guided spacing between sensor and wheel x_z	0,1 ... 0,8 mm	0,1 ... 2 mm
	Side tracking tolerance of the sensor	±1 mm	±1 mm
	Linearity (sensor with magnetic wheel PMIR4)	±0.1°	±0.1°
	Repeatability	±1 digit	±1 digit
	Maximum pulse frequency f_p	50, 20, 10 kHz (standard 50 kHz, max. 480 kHz)	
	Output signals	A, \bar{A} , B, \bar{B} , signal Z, \bar{Z} , status signal ERR	
	Material of housing	Zinc die casting	
	Connection	Cable 8 wire, dia. 5 mm, open cable end. 15 pin SUB-D conn. at the cable end as option. Max. length of the integrated sensor cable: output TTL: 3 m; HTL/TTL24V: 20 m	
	Weight (w/o cable and connector)	30 ±5 g	
	Protection class (EN 60529)	IP67	
Environmental			
EMC	DIN EN 61326		
Temperature	-40 ... +85 °C (-40 ... +185 °F)		



The subsequent counting device must be able to process the specified maximum pulse frequency of the sensor.

Output signals	Saturation voltage	U _H , U _L = 0.2 V U _H , U _L = 0.4 V C _{last} < 10 nF	I _{out} = ±10 mA (U _H = U _B - U _{out}) I _{out} = ±30 mA
	Short circuit current	ISL, ISH < 800 mA ISL, ISH < 90 mA	(U _H , U _L = 0 V) (U _H , U _L = 1.5 V)
	Rise time	t _r , t _f < 200 ns	with cable length 1 m, 10 % ... 90 %

Pulse frequency in dependence on the cable length	Load/cable length	Load/pulse frequency f_p		
		HTL single ended UB = 24 V	TTL/RS422 differential UB = 5 V *	TTL/24 V UB = 24 V
	Max. output current	50 mA	50 mA	10 mA
	R _{last} min.	500 Ω	100 Ω	500 Ω
	C _{last} max.	10 nF	10 nF	1 nF
	200 m	15 kHz	—	—
	100 m	25 kHz	100 kHz	—
	50 m	50 kHz	200 kHz	50 kHz
	10 m	100 kHz	300 kHz	100 kHz

* = consider the voltage loss of the cable; the excitation voltage 5 V ± 5% of the sensor must be guaranteed.

Note: For longer distances (see specification above) you must use min. 0.5 mm² wire for „Excitation+“ and „Excitation GND“ (see signal wiring next page), all signal wires must be min. 0.14 mm²!

POSIROT®
PMIS4, PMIR4
Magnetic incremental encoder



Outline drawing

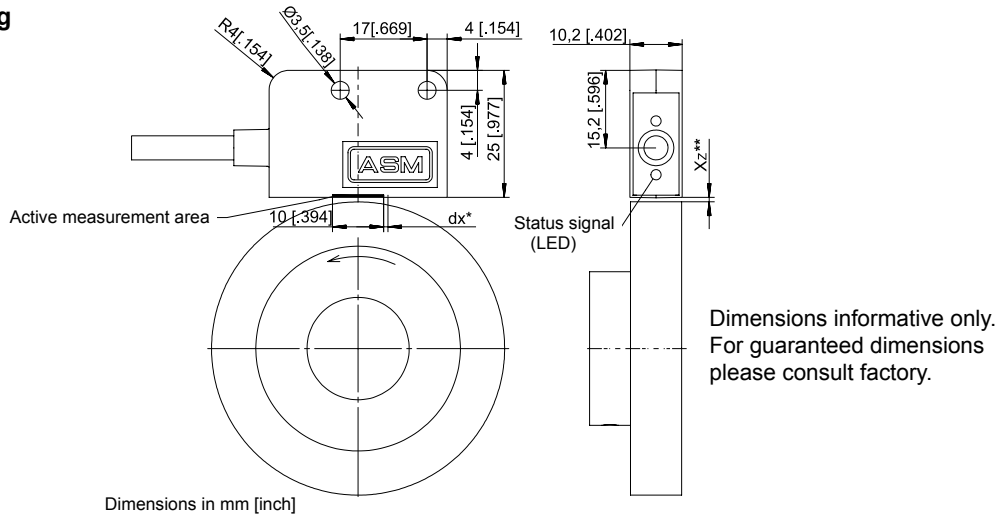

Dimensions informative only.
 For guaranteed dimensions
 please consult factory.

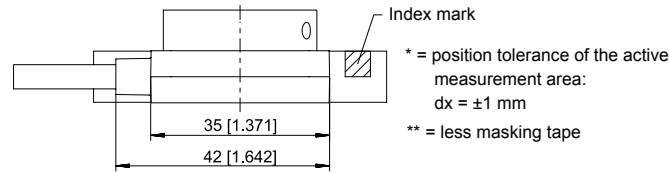

Output signals

**Option Z1
 (signal Z)**

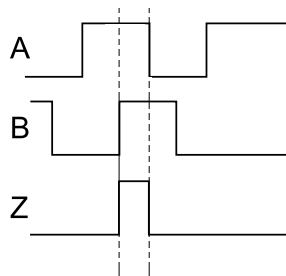

Signal wiring	Signal name			Cable with open end, cable color	Connector SUB-D, pin no. 15 poles	
	Option	Z0	Z1			Z3 *
		B	B	B	white	1
		A	A	A	green	6
		\bar{B}	\bar{B}	ERR	yellow	4
		\bar{A}	\bar{A}	-	grey	7
		-	Z	Z	pink	5
		-	\bar{Z}	-	blue	8
		-	-	-	red	9
					black	12

Z = reference pulse
 ERR = status signal, periodical approx. 16 Hz, for side tracking and velocity errors
 * = status signal ERR available only with HTL (single ended) output

Connection

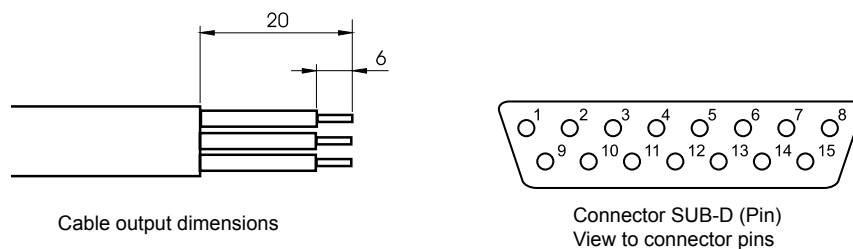

POSIROT®
PMIR4
Incremental magnetic wheels



Specification	Material	Plastic bonded magnetic material or magnetic scale
	Base material	Aluminium
	Signal periods per revolution	From 50 poles/revolution
	Magnetic period	2 mm
	Temperature range	-40 ...+85°C (-40 ... +185 °F)
	Linearity with sensor PMIS4	Approx. ± 0.1°

Data valid in connection with the sensor PMIS4.

Standard magnetic wheels

Type	Poles	∅	Height	Signal periods/rotation	Inside diameter
PMIR4-20-50	50	31.8	18	decade division (refer to the table below)	20H7
PMIR4-20-64	64	40.7	18	binary division (refer to the table below)	20H7
PMIR4-20-90	90	57.3	18	vernier (refer to the table below)	20H7

Further pole numbers, diameters and magnetic periods on request.

Scaling factor Sensor PMIS4-20- ...	PMIR4-20-50		PMIR4-20-64		PMIR4-20-90	
	Signal periods	R.p.m.)* (at 480 kHz)	Signal periods	R.p.m.)* (at 480 kHz)	Signal periods	R.p.m.)* (at 480 kHz)
1	50	6000	64	6000	90	6000
2	100	6000	128	6000	180	6000
4	200	6000	256	6000	360	6000
8	400	6000	512	6000	720	6000
10	500	5760	640	4500	900	3200
16	800	6000	1024	6000	1440	6000
20	1000	5760	1280	4500	1800	3200
25	1250	6000	1600	6000	2250	5120
32	1600	6000	2048	6000	2880	6000
40	2000	5760	2560	4500	3600	3200
50	2500	6000	3200	6000	4500	5120
64	3200	6000	4096	5625	5760	4000
80	4000	5760	5120	4500	7200	3200
100	5000	4608	6400	3600	9000	2560
125	6250	3686	8000	2880	11 250	2048
128	6400	3600	8192	2813	11 520	2000
200	10 000	2304	12 800	1800	18 000	1280
250	12 500	1843	16 000	1440	22 500	1024
256	12 800	1800	16 384	1406	23 040	1000
400	20 000	1152	25 600	900	36 000	640
500	25 000	922	32 000	720	45 000	512
512	25 600	900	32 768	703	46 080	500
1024	51 200	450	65 536	352	92 160	250
2048	102 400	225	131 072	176	184 320	125

)* Maximum revolution per minute mechanically 6.000 R.p.m.

POSIROT®
PMIR4
Incremental magnetic wheels



Outline drawings

PMIR4-20-50

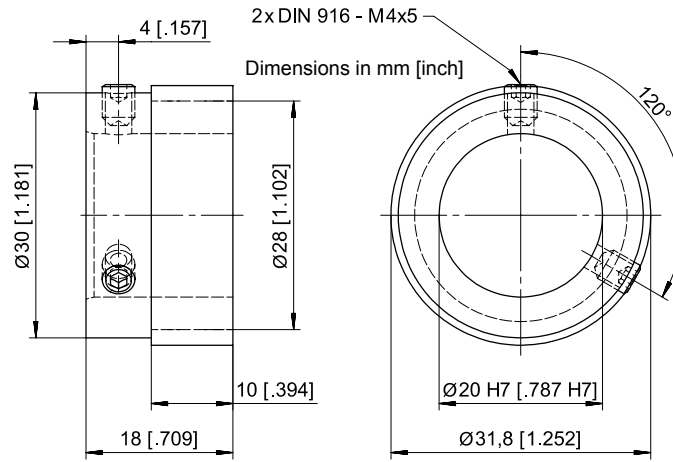

PMIR4-20-64

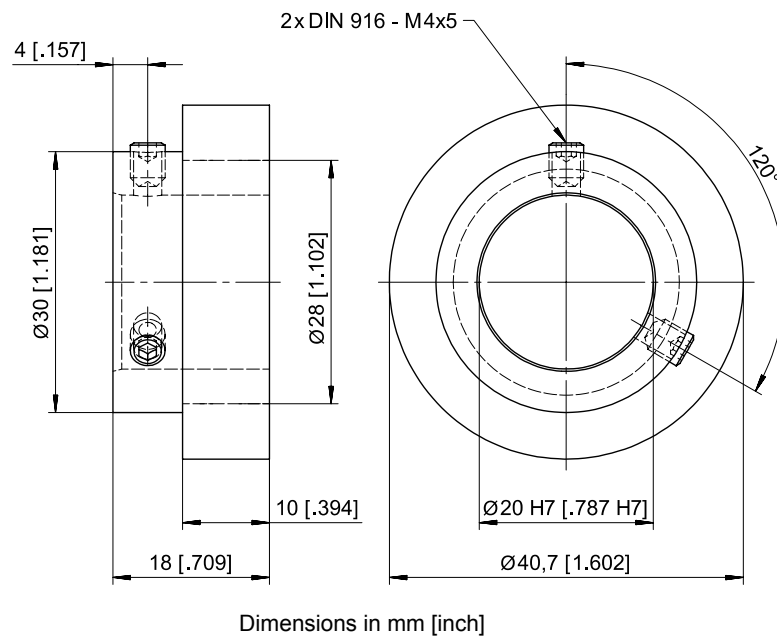

Dimensions informative only.
 For guaranteed dimensions
 please consult factory.

POSIROT®
PMIR4 / PMIR5
Incremental magnetic wheels



Outline drawings

PMIR4-20-90

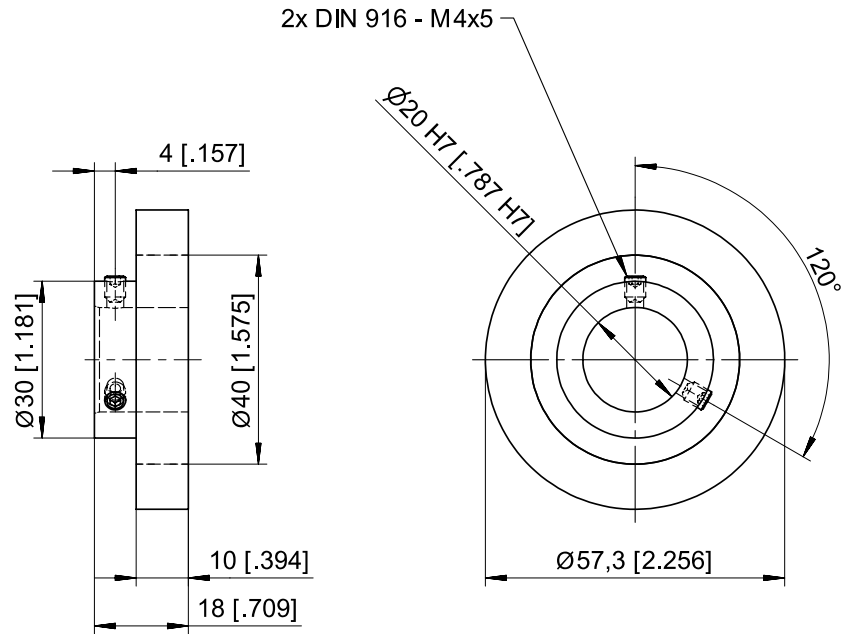

Dimensions in mm [inch]

PMIR5-50-64

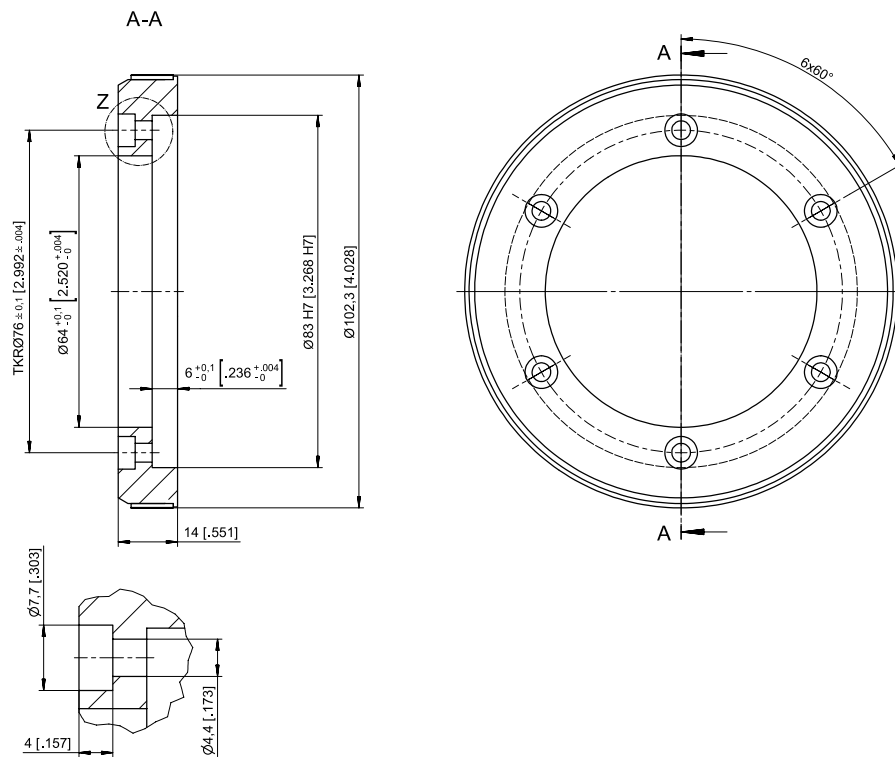

Dimensions informative only.
 For guaranteed dimensions please consult factory.

POSIROT®
PMIS4, PMIR5
Magnetic incremental encoder

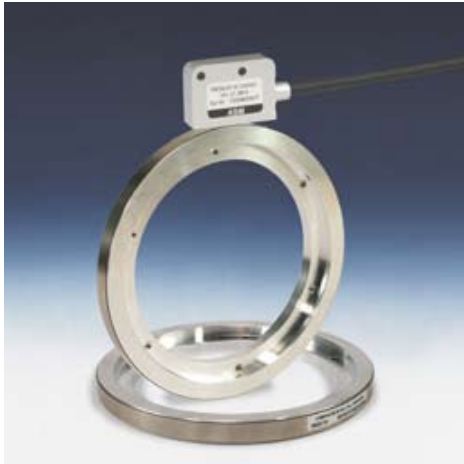

Magnetic wheels for rotative applications with POSIROT® position sensor PMIS4

- All metal housing
- Protection class IP67
- Highest EMC protection
- Large guiding distance of ± 1 mm
- Suitable for harsh environments
- Up to 327,680 pulses/360°

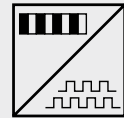

Order Code PMIR5
 (magnetic wheel)



Model name _____

Magnetic period
 50 = 5 mm

Number of poles
 64 / 96 / 160 (other pole numbers on request)

Z signal mark
 O = without / M = with

Inner diameter
 Depending on the number of poles (on request)

Option
 AB = Masking tape

Order Code PMIS4
 (sensor head)
 Specifications see page 35



Model name _____

Magnetic period
 50 = 5 mm

Scaling factor
 See table page 41

Maximum pulse frequency (in kHz, standard 50 kHz)
 50 / 20 / 10 (other frequencies on request, max. 480 kHz)

Output
 HTL = HTL output with excitation 24 V DC, output 24 V
 TTL = TTL output with excitation 5 V DC, output TTL/RS422
 TTL24V = TTL output with excitation 24 V DC, output TTL/10 mA

Signal Z / status signal
 Z0 = A/B w/o signal Z
 Z1 = A/B with signal Z
 Z3 = A/B with signal Z and status signal, only for non-differential (single-ended) outputs

Cable length (in m, standard 2 m) _____

Connection
 S = Open cable end
 P15 = SUB-D connector at the cable end, 15 poles

Order example position magnet ring: PMIR5 - 50 - 64 - M - 83 - AB

Order example sensor: PMIS4 - 50 - 100 - 50KHZ - HTL - Z0 - 2M - S

POSIROT®
PMIR5
Incremental magnetic wheels



Specifications	Material	Plastic bonded magnetic scale
	Base material	Aluminium
	Signal periods per revolution	64 / 96 / 160 poles per revolution
	Magnetic period	5 mm
	Temperature range	-40 ...+120°C (-40 ... -248 °F)
	Linearity with sensor PMIS4	Approx. ± 0.1°

Data valid in connection with the sensor PMIS4.

Standard magnet rings

Type	Poles	∅	Height	Signal periods/revolution	Inner diameter ∅
PMIR5-50-64	64	102.3	14	Divisions see table below	∅83 H7
PMIR5-50-96	96	153.2	14	Divisions see table below	On request
PMIR5-50-160	160	255.1	14	Divisions see table below	On request

Positionsmagnet rings with other number of poles, diameters or magnetic periods on request.

Scaling factor sensor PMIS4-50- ...	PMIR5-50-64		PMIR5-50-96		PMIR5-50-160	
	Signal periods	R.p.m.)* (at 480 kHz)	Signal periods	R.p.m.)* (at 480 kHz)	Signal periods	R.p.m.)* (at 480 kHz)
1	64	3000	96	3000	160	3000
2	128	3000	192	3000	320	3000
4	256	3000	384	3000	640	3000
8	512	3000	768	3000	1280	3000
10	640	3000	960	3000	1600	1800
16	1024	3000	1536	3000	2560	3000
20	1280	3000	1920	3000	3200	1800
25	1600	3000	2400	3000	4000	2880
32	2048	3000	3072	3000	5120	3000
40	2560	3000	3840	3000	6400	1800
50	3200	3000	4800	3000	8000	2880
64	4096	3000	6144	3000	10 240	2250
80	5120	3000	7680	3000	12 800	1800
100	6400	3000	9600	2400	16 000	1440
125	8000	2880	12 000	1920	20 000	1152
128	8192	2813	12 288	1875	20 480	1125
200	12 800	1800	19 200	1200	32 000	720
250	16 000	1440	24 000	960	40 000	576
256	16 384	1406	24 576	938	40 960	563
400	25 600	900	38 400	600	64 000	360
500	32 000	720	48 000	480	80 000	288
512	32 768	703	49 152	469	81 920	281
1024	65 536	352	98 304	234	163 840	141
2048	131 072	176	196 608	117	327 680	70

)* Maximum r.p.m. mechanically 3.000 U/min

PRODIS[®]
PD-ADC
Digital process meter for analog sensors



- For POSIROT[®] and POSITILT[®] position sensors with analog outputs:
Voltage 0 ... 10 V; 0.5 ... 10V; 0.5 ... 4.5 V
Current 4 ... 20 mA
Voltage divider
- **Integrated sensor supply (24 V DC)**
- **6-digit LED display**
- **RS-232 interface**
- **Optional 4 comparator outputs**
- **Easy programming**

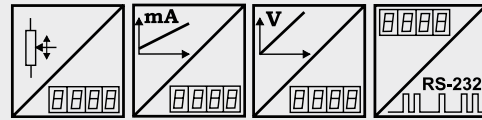

Description

PRODIS-ADC is designed for use with analog position sensors to display angles and displacements. A high resolution A/D converter processes signals from sensors with voltage output 0 ... 10 V, current output 0/4 ... 20 mA or voltage divider (potentiometer). The meter is programmable to display values within preset start/end range or values in units as inches, mm or degrees. A tare function or programming lock can be activated with two control terminals. Sensor excitation is supplied by the meter. With four membrane keys all parameters can be programmed for the special applications. Optional comparator functions with 4 NPN open-collector outputs are available, additional 2 of them have relay output.

Specification		
Display		6-digit, 7-segment LED, height 14 mm, decimal point programmable
Counting rate		1 ... 25/s programmable
Measurement accuracy		±0.05 % f.s.
Excitation voltage/current		24 V DC ±10%/150 mA, residual ripple 1% _{SS} ; 85-250 V AC, 50-60 Hz/180 mA max.
Sensor excitation		24 V DC/300 mA
Input		Two channels, each for: Voltage 0...10V; 0.5 ... 10V; 0.5 ... 4.5 V; max. 24V Current 0/4...20 mA, load 100 Ω, I _{max} <30 mA Voltage divider R _{min} =500 Ω, 0 ... 5 V One input or the difference between both inputs can be chosen by programming
Control input		2 control inputs 24 V, active low
Comparator outputs (option)	Relay NPN	250 V AC/5 A, 30 V DC/5 A 24 V max./50 mA to GND
Connection		Terminal strip 12 pole, excitation 3 pole
Temperature coefficient		±20 x 10 ⁻⁶ / °C [±36 x 10 ⁻⁶ / °F]
Operating temperature / storage temperature		-10...+40 °C [14...+104 °F] / -20...+85 °C [-4...+185 °F]

Order Code PRODIS-ADC

Model name

Excitation Voltage

24VDC = 24 V DC
 230VAC = 85...250 V AC

Options

REL2 = Comparator
 DT = Desktop version

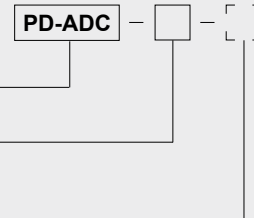

Order example: PD - ADC - 24VDC - REL2

PRODIS[®]
PD-ADC
Digital process meter for analog sensors



Specifications (Cont'd)	Weight	24 V DC: approx. 250 g; 230 V AC: approx.. 400 g
	Protection class	Front IP60, rear IP40
	Humidity	Max. 80 % R. H., non condensing
	Safety of equipment	Directive 73/23/EWG: DIN EN61010:2002-03
	Electromagnetic compatibility, EMC	Directive 89/336/EWG
Programmable parameters / value range	Value range offset, limit values	-999999 to +999999
	Divisor, multiplier	0 to 999999
	Other programmable parameters	Decimal point position, display brightness
	Control input terminals	Key lock, display value hold, tare function

Wiring basic unit	Signals	Connector X1 pin no.	Connector X2 pin no.
		Sensor excitation +U _b 24 V	1
	Sensor excitation 0 V (GND)	2	
	Control input terminal 1	3	
	Control input terminal 2	4	
	Voltage input terminal 0 ... 10 V, channel 1	5	
	Voltage input terminal 0 ... 10 V, channel 2	6	
	Current input terminal 0/4 ... 20 mA, channel 1	7	
	Current input terminal 0/4 ... 20 mA, channel 2	8	
	Voltage divider input terminal R1K, channel 1	9	
	Voltage divider input terminal R1K, channel 2	10	
	Reference voltage output terminal 5 V for R1K	11	
	GND	12	
	PD-ADC-24VDC		
	Excitation +24 V		13
	Excitation 0 V (GND)		14
	PD-ADC-230VAC		
	Excitation		13, 15
	Protective ground		14

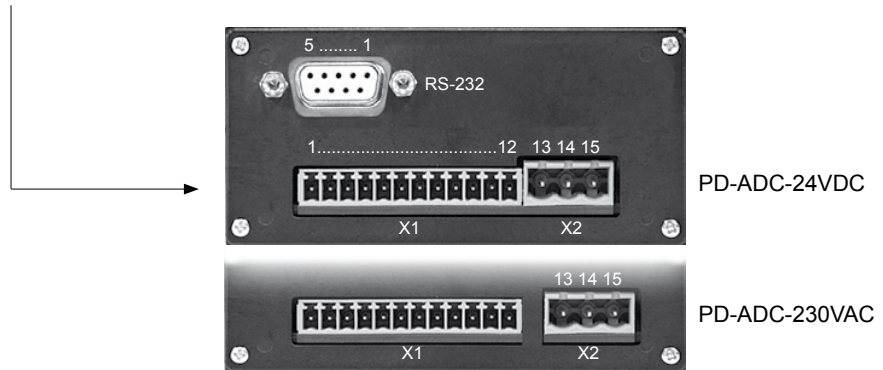

RS-232 interface	Level	RS-232: ±8 V, galvanically isolated	
	Data format	1 start bit, 8 data bits, 1 stop bit, no parity	
	Transmission rate	9600 Baud	
	Signals	Connector X3 Pin No.	SUB-D Pin No.
	TxD	17	2
RxD	16	3	
GND	18	5	

Rear view with comparator outputs and outline drawings see pages 48 and 49.



- For POSIROT® position sensors with incremental outputs
- Integrated sensor supply
- Counting rate up to 250 kHz (<1 MHz edge frequency)
- 6-digit LED display
- RS-232 interface
- Optional 4 comparator outputs
- Easy programming

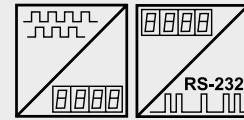

Description

PRODIS-INC is designed for use with incremental position sensors to display angles. The fast counter processes 90° phase shifted A,B signals (quadrature signals) for direction and counting information. Sensor excitation is supplied from the meter. With four membrane keys all parameters can be programmed for the special application. An zero signal and a reference signal can be used for calibration of the measurement system. Optional comparator functions with 4 NPN open-collector outputs are available, additional 2 of them have relay output.

Specifications	Display	6-digit, 7-segment LED, height 14 mm, decimal point programmable
	Excitation voltage/current	24 V DC ±10%/150 mA, residual ripple 1% _{ss} ; 85-250 V AC, 50-60 Hz/180 mA max.
	Counting frequency	250 kHz max., 1 MHz edge frequency
	Sensor excitation	24 V DC/300 mA or 5V DC/500 mA
	Inputs	A, B, Z, T (reference signal)
	Connection	Terminal strip 12-pole, excitation 3-pole
	Operating temperature	-10 ... +40 °C [14 ... +104 °F]
	Storage temperature	-20 ... +85 °C [-4 ... +185 °F]
	Weight	24 V DC: approx. 250 g; 230 V AC: approx. 400 g
	Protection class	Front IP60, rear IP40
	Humidity	Max. 80 % R.H., non condensing
	Comparator outputs (option)	Relay NPN
	Safety of equipment	Directive 73/23/EWG: DIN EN61010:2002-03
	EMC	Directive 89/336/EWG

Order Code PRODIS-INC

Model name

Excitation voltage

24VDC = 24 V DC
230VAC = 85...250 V AC

Sensor excitation voltage

G24V = 24 V DC
G5V = 5 V DC

Sensor signal

HTL = HTL level with excitation voltage G24V
TTL = TTL level with excitation voltage G5V or G24V

Options

REL2 = Comparator
DT = Desktop version

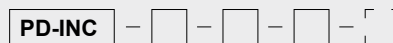

Order example: PD - INC - 24VDC - G24V - HTL - REL2

Programmable parameters / value range	Value range display, offset, limit values	-999999 to +999999
	Divisor, Multiplier	0 to 999999
	Other programmable parameters	Counting direction, decimal point position, last-value memory, Z signal evaluation, display brightness
	Signal T	Manual zero, key lock, display value hold, Z release, relative measurement activation

Wiring basic unit	Signals	Connector X1 pin no.	Connector X2 pin no.
	Sensor +U _B		1
Sensor 0 V (GND)		2	
Signal A		4	
Signal \bar{A}		5	
Signal B		6	
Signal \bar{B}		7	
Signal Z (zero signal)		8	
Signal \bar{Z} (zero signal)		9	
Signal T (reference signal)		10	
Signal \bar{T} (reference signal)		11	
GND		12	
PD-INC-24VDC			
Excitation +24 V			13
Excitation 0 V (GND)			14
PD-INC-230VAC			
Excitation			13, 15
Protective ground			14

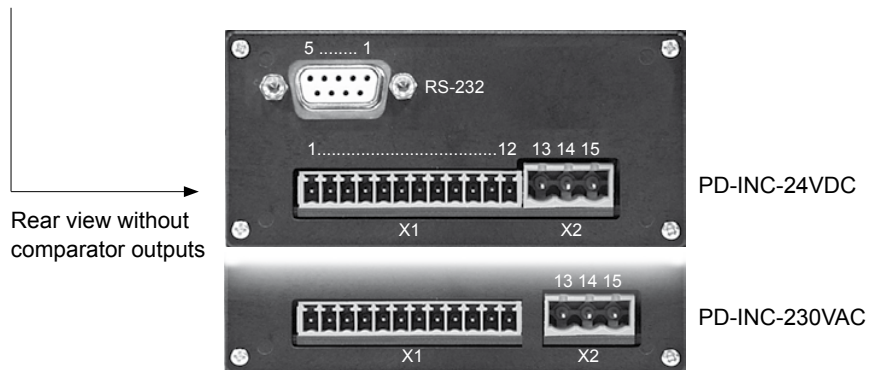

RS-232 interface	Level	RS-232: ±8 V, galvanically isolated	
	Data format	1 start bit, 8 data bits, 1 stop bit, no parity	
	Transmission rate	4800 / 9600 / ... / 115200 Baud	
	Signals	Connector X3 Pin No.	SUB-D Pin No.
	TxD	17	2
RxD	16	3	
GND	18	5	

Rear view with comparator outputs and outline drawings see pages 48 and 49.



- For POSIROT® position sensors with SSI output
- Integrated sensor supply
- 6-digit LED display
- RS-232 interface
- Optional 4 comparator outputs
- Easy programming

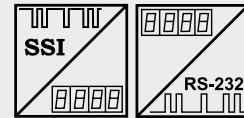

PRODIS-SSI is designed for use with SSI position sensors to display angle and displacement. Via the CLOCK lines, a sequence of pulses will be transmitted, the input DATA lines will read the sensor's serial bit sequence. The meter is programmable to display values within preset start/end range or values in units as inches, mm or degrees. A tare function or programming lock can be activated with two control terminals. Sensor excitation is supplied by the meter. With four membrane keys, all parameters can be programmed for the special applications. Optional comparator functions with 4 NPN open-collector outputs are available, additional 2 of them have relay output.

Specifications		
Display		6-digit, 7-segment LED, 14 mm high, decimal point programmable
Sampling rate		100/s
Excitation voltage/current		24 V DC ±10%/150 mA, residual ripple 1% _{pp} ; 85-250 V AC, 50-60 Hz/180 mA max.
Sensor excitation		24 V DC/200 mA or 5 V DC/200 mA
Inputs		DATA, $\overline{\text{DATA}}$ (RS-422)
Outputs		CLOCK, $\overline{\text{CLOCK}}$ (RS-422)
Control inputs		2 control inputs 24 V, active low
Comparator outputs (option)	Relay NPN	250 V AC/5 A, 30 V DC/5 A 24 V max./50 mA to GND
Connection		Terminal strip 12-pole, excitation 3-pole
Operating temperature		-10 ... +40 °C [14 ... +104 °F]
Storage temperature		-20 ... +85 °C [-4 ... +185 °F]
Weight		24 V DC: approx. 250 g; 230 V AC: approx. 400 g

Order Code PRODIS-SSI

Model name

Excitation Voltage

24VDC = 24 V DC

230VAC = 85...250 V AC

Sensor Excitation

G24V = 24 V DC

G5V = 5 V DC

Options

REL2 = Comparator

DT = Desktop version

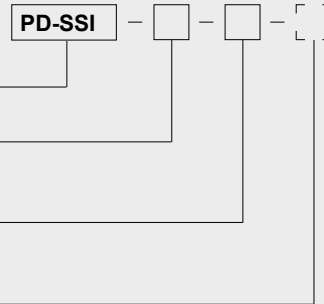

Order example: PD - SSI - 230VAC - G5V

Specifications (continuation)	Protection class	Front IP60, back IP40
	Humidity	Max. 80 % r.h., non condensing
	Safety of equipment	Directive 73/23/EWG: DIN EN61010:2002-03
	Electromagnetic compatibility, EMC	Directive 89/336/EWG

Programmable Parameters / Value range	Value range offset, limit values	-999999 to +999999
	Divisor, multiplier	0 to 999999
	Other programmable parameters	Decimal point position, display brightness
	Programmable SSI parameters	Gray/dual code, sign, sampling rate, data format
	Control inputs	Key lock, display value hold, tare function

Wiring basic unit	Signals	Connector X1 pin no.	Connector X2 pin no.
	Sensor excitation +U _B (24 V or 5 V)		1
Sensor excitation 0 V (GND)		2	
Control input 1: tare function		3	
Control input 2: programming lock		4	
Not used		5 / 6	
Output $\overline{\text{CLOCK}}$		7	
Output $\overline{\text{CLOCK}}$		8	
Input $\overline{\text{DATA}}$		9	
Input $\overline{\text{DATA}}$		10	
Do not connect!		11	
GND		12	
PD-SSI-24VDC			
Excitation +24 V			13
Excitation 0 V (GND)			14
PD-SSI-230VAC			
Excitation			13, 15
Protective ground			14

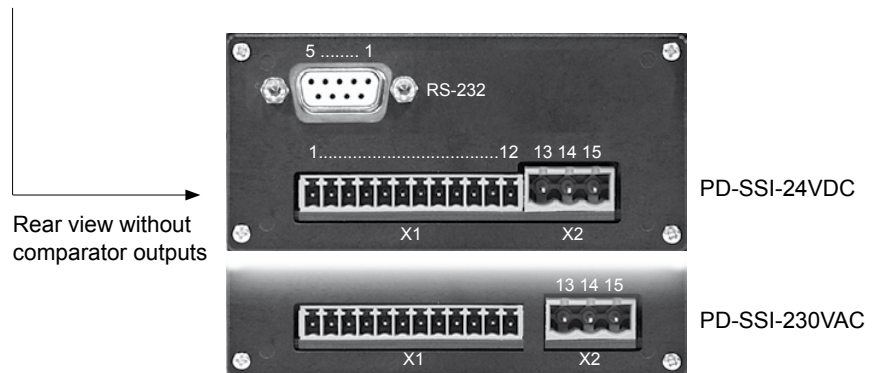

RS-232 interface	Level	RS-232: ±8 V, galvanically isolated	
	Data format	1 start bit, 8 data bits, 1 stop bit, no parity	
	Transmission rate	9600 Baud	
	Signals	Connector X3 pin no.	SUB-D pin no.
	TxD	17	2
	RxD	16	3
GND	18	5	

Rear view with comparator outputs and outline drawings see the following pages.

Rear view with
comparator outputs

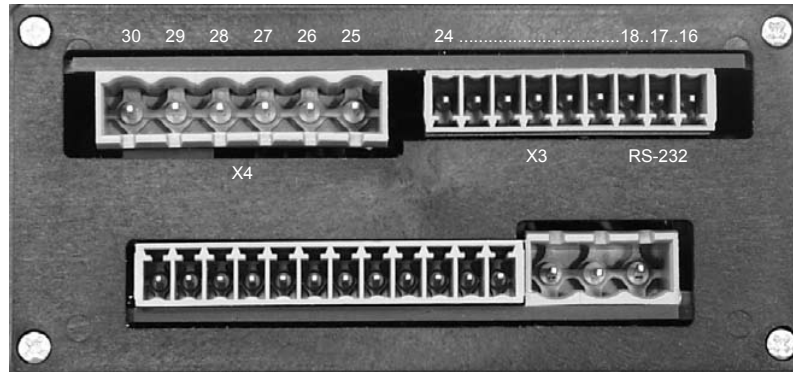

Comparator function (option)	Comparator	Comparator output				LED
		NPN Collector	Connector X3 pin no.	Relay	Connector X4 pin no.	
Comparator 1	NPN1	20	Relay 1	25	LED1	
			NO	27		
			NC	26		
Comparator 2	NPN2	21	Relay 2	28	LED2	
			NO	30		
			NC	29		
Comparator 3	NPN3	22				
Comparator 4	NPN4	23				
	NPN GND	24				
	NPN U _B (+24V)	19				

Desktop version
(option)

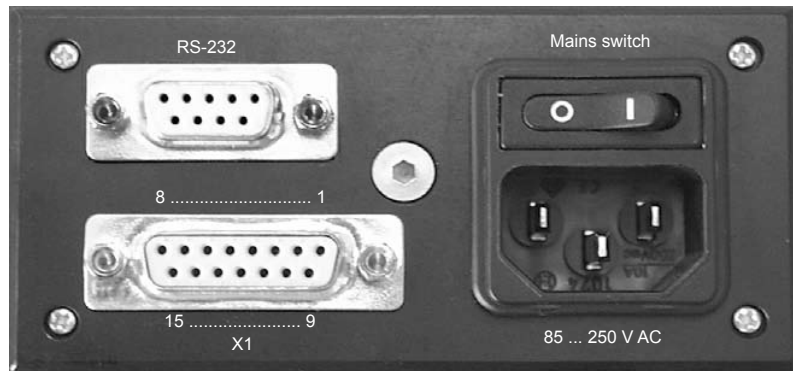

Wiring of connector X1 see table at page 43 (PD-ADC), page 45 (PD-INC) resp. page 47 (PD-SSI).

Outline drawing

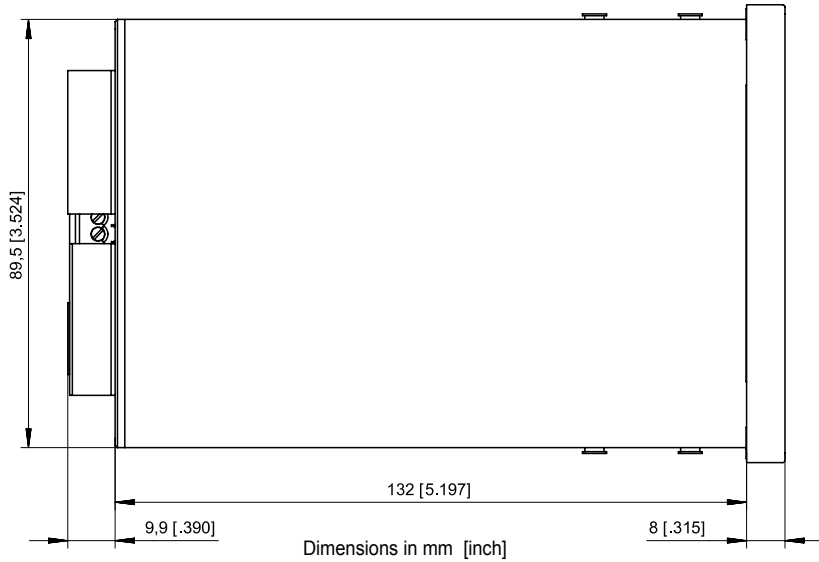
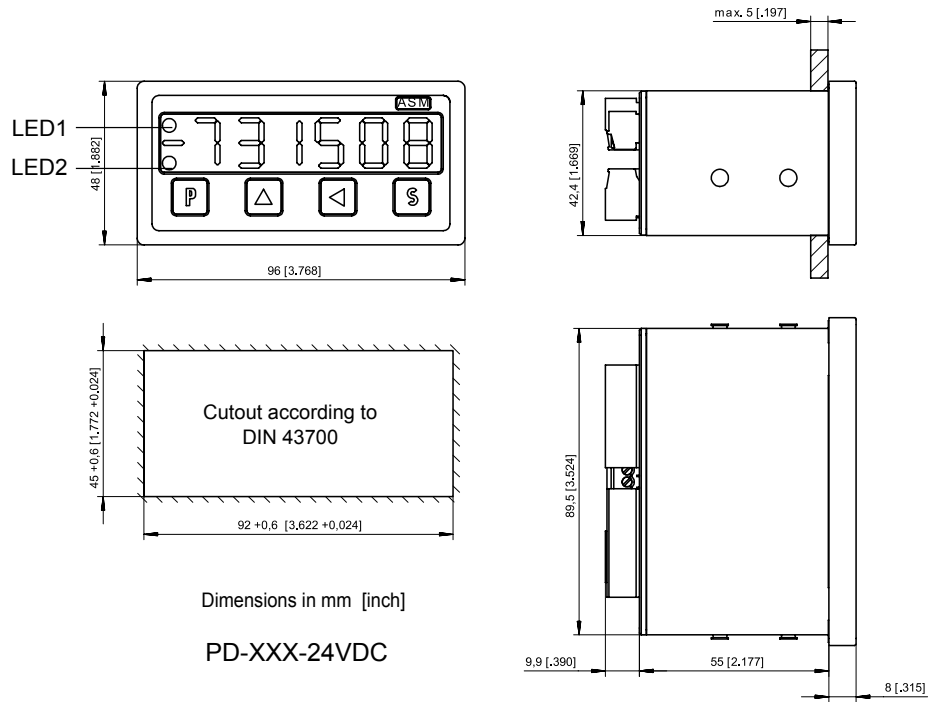

PD-XXX-230VAC

Dimensions informative only.
 For guaranteed dimensions
 please consult factory.

Available Position Sensor Catalogs



Information request

Fax +49-(0)8123-986-500

Company: _____
Mr./Mrs.: _____
Department: _____
Street: _____
Town: _____
Tel. / Fax: _____
e-mail: _____
Website: _____

• Please send me detailed information/catalog on the following products:

- WS® Cable actuated Position Sensors
- POSICHRON® Magnetostrictive Position Sensors
- POSIMAG® Magnetic Scale Position Sensors

Protection classes according to EN 60529



2nd char. numeral: Protection against ingress of water 1st char. numeral: Protection against solid foreign objects									
Protection against ...	Non protected	Falling water drops vertical / 15°	Spraying water	Splashing water	Water jets	Powerful water jets	Temporary immersion	Continuous Immersion	
IEC 529 DIN 40050	IP .. 0	IP .. 1	IP .. 2	IP .. 3	IP .. 4	IP .. 5	IP .. 6	IP .. 7	IP .. 8
IP 0 .. Non protected	IP 00								
IP 1 .. Solid foreign objects diameter ≥ 50 mm	IP 10	IP 11	IP 12						
IP 2 .. Solid foreign objects diameter ≥ 12,5 mm	IP 20	IP 21	IP 22	IP 23					
IP 3 .. Solid foreign objects diameter ≥ 2,5 mm	IP 30	IP 31	IP 32	IP 33	IP 34				
IP 4 .. Solid foreign objects diameter ≥ 1 mm	IP 40	IP 41	IP 42	IP 43	IP 44				
IP 5 .. Dust-protected	IP 50		IP 52	IP 53	IP 54	IP 55	IP 56		
IP 6 .. Dust-tight	IP 60				IP 64	IP 65	IP 66	IP 67	IP 68

* Depth and duration of immersion must be specified!

IP69K - Water at high pressure / steam jet cleaning



perfect in sensors.

ASM GmbH

Am Bleichbach 18 - 22
85452 Moosinning

Germany

Tel. +49-(0)8123-986-0
Fax +49-(0)8123-986-500
info@asm-sensor.de
www.asm-sensor.de

ASM Sales Office UK

Tanyard House, High Street
Measham, Derbs DE12 7HR

United Kingdom

Tel. +44-(0)845-1222-123
Fax +44-(0)845-1222-124
uk@asm-sensor.com
www.asm-sensor.com

ASM Agence France

1, rue du Neuland
67560 Rosheim

France

Tel. +33-(0)3-88 49 25 35
Fax +33-(0)3-88 48 06 23
france@asm-sensor.com
www.asm-sensor.com

ASM Sensors, Inc.

650 W. Grand Ave., Unit 205
Elmhurst, IL 60126

USA

Tel. +1-(630)-832 3202
Fax +1-(630)-832 3204
info@asmsensors.com
www.asmsensors.com