

■ General Description

The AME8815 family of linear regulators feature low quiescent current (45 μ A typ.) with low dropout voltage, making them ideal for battery applications. It is available in D²PAK and TO-220 packages. The space-efficient SOT-223 and DPAK package are attractive for "Pocket" and "Hand Held" applications.

Output voltages are set at the factory and trimmed to 1.5% accuracy.

These rugged devices have both Thermal Shutdown, and Current Fold-back to prevent device failure under the "Worst" of operating conditions.

The AME8815 is stable with an output capacitance of 4.7 μ F or greater.

■ Functional Block Diagram

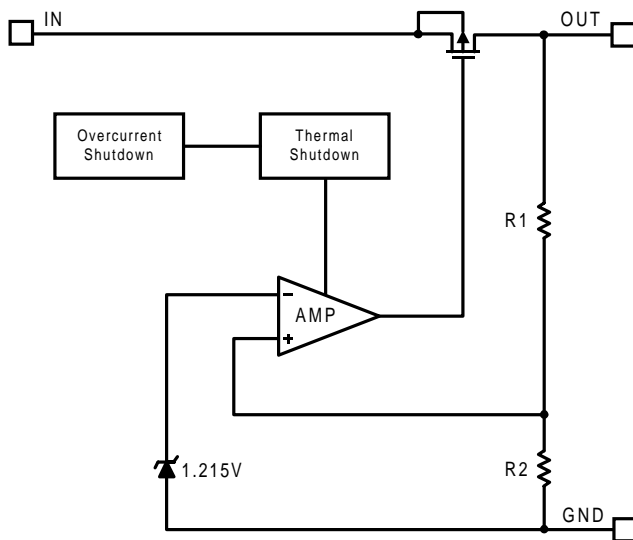

■ Features

- Very Low Dropout Voltage
- Guaranteed 1.5A Output
- Accurate to within 1.5%
- 45 μ A Quiescent Current Typically
- Over-Temperature Shutdown
- Current Limiting
- Short Circuit Current Fold-back
- Space-Efficient DPAK or SOT223 Package
- Low Temperature Coefficient

■ Applications

- Instrumentation
- Portable Electronics
- Wireless Devices
- PC Peripherals
- Battery Powered Widgets

■ Typical Application

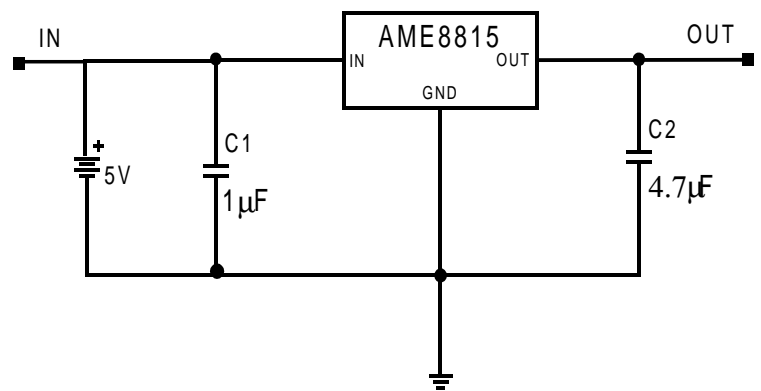



Pin Configuration

SOT-223 Top View

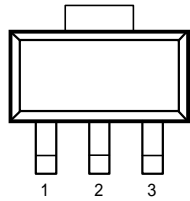

- 1. V_{IN}
- 2. GND (heat sink)
- 3. V_{OUT}

AME8815AEGTXXX

SOT-223 Top View

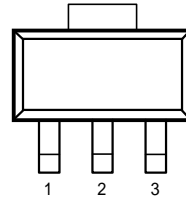

- 1. GND
- 2. V_{OUT} (heat sink)
- 3. V_{IN}

AME8815BEGTXXX

TO-252 (DPAK-2) Top View

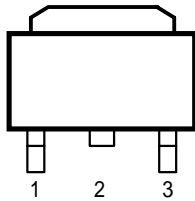

- 1. V_{IN}
- 2. GND (heat sink)
- 3. V_{OUT}

AME8815AECSXXX

TO-252 (DPAK-2) Top View

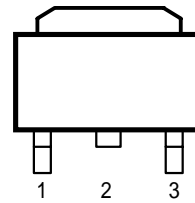

- 1. GND
- 2. V_{OUT} (heat sink)
- 3. V_{IN}

AME8815BECSXXX

TO-220 Top View

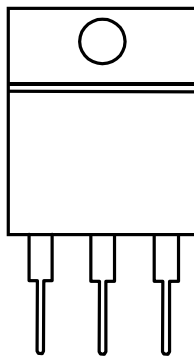

- 1. V_{IN}
- 2. GND (heat sink)
- 3. V_{OUT}

AME8815AEBTXXX

TO-220 Top View

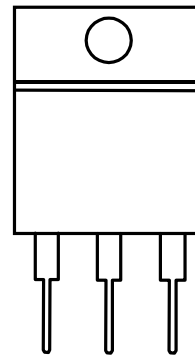

- 1. GND
- 2. V_{OUT} (heat sink)
- 3. V_{IN}

AME8815BEBTXXX



■ Ordering Information

AME8815 X X X X XXX

Voltage

- 150: V=1.5V
- 180: V=1.8V
- 250: V=2.5V
- 330: V=3.3V
- 475: V=4.75V
- 500: V=5.0V

Number of Pin

- S: 2
- T: 3

Package

- B: TO-220
- C: TO-252
- D: TO-263
- G: SOT-223

Operating Temperature

- C: 0°C to 70°C
- E: -40°C to 85°C
- M: -40°C to 125°C

Pin Configuration

Please consult AME sales office or authorized Rep./Distr. For other output voltage and package type availability.



■ Ordering Information

Part Number	Marking	Output	Package	Operating Temp.
AME8815AEBT150	AME8815 AEBT150 yyww	1.50	TO-220	-40°C to +85°C
AME8815AEBT180	AME8815 AEBT180 yyww	1.80	TO-220	-40°C to +85°C
AME8815AEBT250	AME8815 AEBT250 yyww	2.50	TO-220	-40°C to +85°C
AME8815AEBT330	AME8815 AEBT330 yyww	3.30	TO-220	-40°C to +85°C
AME8815AEBT475	AME8815 AEBT475 yyww	4.75	TO-220	-40°C to +85°C
AME8815AEBT500	AME8815 AEBT500 yyww	5.00	TO-220	-40°C to +85°C
AME8815AECS150	AME8815 AECS150 yyww	1.50	TO-252	-40°C to +85°C
AME8815AECS180	AME8815 AECS180 yyww	1.80	TO-252	-40°C to +85°C
AME8815AECS250	AME8815 AECS250 yyww	2.50	TO-252	-40°C to +85°C
AME8815AECS330	AME8815 AECS330 yyww	3.30	TO-252	-40°C to +85°C
AME8815AECS475	AME8815 AECS475 yyww	4.75	TO-252	-40°C to +85°C
AME8815AECS500	AME8815 AECS500 yyww	5.00	TO-252	-40°C to +85°C

■ Ordering Information

Part Number	Marking	Output	Package	Operating Temp.
AME8815AEDS150	AME8815 AEDS150 yyww	1.50	TO-263	-40°C to +85°C
AME8815AEDS180	AME8815 AEDS180 yyww	1.80	TO-263	-40°C to +85°C
AME8815AEDS250	AME8815 AEDS250 yyww	2.50	TO-263	-40°C to +85°C
AME8815AEDS330	AME8815 AEDS330 yyww	3.30	TO-263	-40°C to +85°C
AME8815AEDS475	AME8815 AEDS475 yyww	4.75	TO-263	-40°C to +85°C
AME8815AEDS500	AME8815 AEDS500 yyww	5.00	TO-263	-40°C to +85°C
AME8815AEGT150	ASPww	1.50	SOT-223	-40°C to +85°C
AME8815AEGT180	AQUww	1.80	SOT-223	-40°C to +85°C
AME8815AEGT250	APRww	2.50	SOT-223	-40°C to +85°C
AME8815AEGT330	AKCww	3.30	SOT-223	-40°C to +85°C
AME8815AEGT475	AQRww	4.75	SOT-223	-40°C to +85°C
AME8815AEGT500	AQSww	5.00	SOT-223	-40°C to +85°C



■ Ordering Information

Part Number	Marking	Output	Package	Operating Temp.
AME8815BEBT150	AME8815 BEBT150 yyww	1.50	TO-220	-40°C to +85°C
AME8815BEBT180	AME8815 BEBT180 yyww	1.80	TO-220	-40°C to +85°C
AME8815BEBT250	AME8815 BEBT250 yyww	2.50	TO-220	-40°C to +85°C
AME8815BEBT330	AME8815 BEBT330 yyww	3.30	TO-220	-40°C to +85°C
AME8815BEBT475	AME8815 BEBT475 yyww	4.75	TO-220	-40°C to +85°C
AME8815BEBT500	AME8815 BEBT500 yyww	5.00	TO-220	-40°C to +85°C
AME8815BECS150	AME8815 BECS150 yyww	1.50	TO-252	-40°C to +85°C
AME8815BECS180	AME8815 BECS180 yyww	1.80	TO-252	-40°C to +85°C
AME8815BECS250	AME8815 BECS250 yyww	2.50	TO-252	-40°C to +85°C
AME8815BECS330	AME8815 BECS330 yyww	3.30	TO-252	-40°C to +85°C
AME8815BECS475	AME8815 BECS475 yyww	4.75	TO-252	-40°C to +85°C
AME8815BECS500	AME8815 BECS500 yyww	5.00	TO-252	-40°C to +85°C

■ Ordering Information

Part Number	Marking	Output	Package	Operating Temp.
AME8815BEDS150	AME8815 BEDS150 yyww	1.50	TO-263	-40°C to +85°C
AME8815BEDS180	AME8815 BEDS180 yyww	1.80	TO-263	-40°C to +85°C
AME8815BEDS250	AME8815 BEDS250 yyww	2.50	TO-263	-40°C to +85°C
AME8815BEDS330	AME8815 BEDS330 yyww	3.30	TO-263	-40°C to +85°C
AME8815BEDS475	AME8815 BEDS475 yyww	4.75	TO-263	-40°C to +85°C
AME8815BEDS500	AME8815 BEDS500 yyww	5.00	TO-263	-40°C to +85°C
AME8815BEGT150	AJYww	1.50	SOT-223	-40°C to +85°C
AME8815BEGT180	AJZww	1.80	SOT-223	-40°C to +85°C
AME8815BEGT250	AKBww	2.50	SOT-223	-40°C to +85°C
AME8815BEGT330	AKDww	3.30	SOT-223	-40°C to +85°C
AME8815BEGT475	AMNww	4.75	SOT-223	-40°C to +85°C
AME8815BEGT500	AQTww	5.00	SOT-223	-40°C to +85°C



■ **Absolute Maximum Ratings:**

Parameter	Maximum	Unit
Input Voltage	8	V
Output Current	$P_D / (V_{IN} - V_O)$	mA
Output Voltage	GND - 0.3 to $V_{IN} + 0.3$	V
ESD Classification	B	

Caution: Stress above the listed absolute maximum rating may cause permanent damage to the device.

■ **Recommended operating Conditions:**

Parameter	Rating	Unit
Ambient Temperature Range	-40 to +85	°C
Junction Temperature	-40 to +125	°C

■ **Thermal Information**

Parameter	Maximum	Unit
Thermal Resistance (θ_{ja})	SOT-223	160
	TO-252 (DPAK)	90
	D ² PAK	60
	TO-220	50
Internal Power Dissipation (P_D) ($\Delta T = 100^\circ\text{C}$)	SOT-223	625
	TO-252 (DPAK)	1200
	D ² PAK	2800
	TO-220	3000
Maximum Junction Temperature	150	°C
Maximum Lead Temperature (10 Sec)	300	°C

■ Electrical Specifications

$V_{IN} = V_{O(nom)} + 2V$, $T_A = 25^{\circ}C$ unless otherwise noted

Parameter	Symbol	Test Condition	Min	Typ	Max	Units	
Input Voltage	V_{IN}		Note 1		7	V	
Output Voltage Accuracy	V_O	$I_O=1mA$	-1.5		1.5	%	
Dropout Voltage	$V_{DROPOUT}$	$I_O=1.5A$ $V_O=V_{ONOM}-2.0\%$	$1.4V < V_{O(NOM)} \leq 2.0V$	See chart	1300	mV	
			$2.0V < V_{O(NOM)} \leq 2.8V$		800		
			$2.8V < V_{O(NOM)}$		600		
Output Current	I_O	$V_O > 1.2V$	1500			mA	
Current Limit	I_{LIM}	$V_O > 1.2V$	1500	2000		mA	
Short Circuit Current	I_{SC}	$V_O < 0.4V$		750		mA	
Quiescent Current	I_Q	$I_O=0mA$		45	70	μA	
Ground Pin Current	I_{GND}	$I_O=1mA$ to 1500mA		45		μA	
Line Regulation	REG_{LINE}	$I_O=1mA$ $V_{IN}=V_O+1$ to V_O+2	$V_O < 2.0V$	-0.15		0.15	%
			$4.0V > V_O \geq 2.0V$	-0.1	0.02	0.1	%
			$4.0V \leq V_O$	-0.4		0.4	%
Load Regulation	REG_{LOAD}	$I_O=1mA$ to 1500mA	-1	0.2	1	%	
Over Temperature Shutdown	OTS			150		$^{\circ}C$	
Over Temperature Hysteresis	OTH			30		$^{\circ}C$	
V_O Temperature Coefficient	TC			30		ppm/ $^{\circ}C$	
Power Supply Rejection	PSRR	$I_O=100mA$ $C_O=4.7\mu F$	$f=1kHz$		50	dB	
			$f=10kHz$		20		
			$f=100kHz$		15		
Output Voltage Noise	eN	$f=10Hz$ to 100kHz $I_O=10mA$			30	μV_{rms}	

Note1: $V_{IN(min)} = V_{OUT} + V_{DROPOUT}$



■ Detailed Description

The AME8815 family of CMOS regulators contain a PMOS pass transistor, voltage reference, error amplifier, over-current protection, and thermal shutdown.

The P-channel pass transistor receives data from the error amplifier, over-current shutdown, and thermal protection circuits. During normal operation, the error amplifier compares the output voltage to a precision reference. Over-current and Thermal shutdown circuits become active when the junction temperature exceeds 150°C, or the current exceeds 2.2A. During thermal shutdown, the output voltage remains low. Normal operation is restored when the junction temperature drops below 120°C.

The AME8815 behaves like a current source when the load reaches 2.2A. However, if the load impedance drops below 0.3 ohms, the current drops back to 600mA to prevent excessive power dissipation. Normal operation is restored when the load resistance exceeds 0.75 ohms.

■ External Capacitors

The AME8815 is stable with an output capacitor to ground of 4.7 μ F or greater. Ceramic capacitors have the lowest ESR, and will offer the best AC performance. Conversely, Aluminum Electrolytic capacitors exhibit the highest ESR, resulting in the poorest AC response. Unfortunately, large value ceramic capacitors are comparatively expensive. One option is to parallel a 0.1 μ F ceramic capacitor with a 10 μ F Aluminum Electrolytic. The benefit is low ESR, high capacitance, and low overall cost.

A second capacitor is recommended between the input and ground to stabilize V_{in} . The input capacitor should be at least 0.1 μ F to have a beneficial effect.

All capacitors should be placed in close proximity to the pins. A "Quiet" ground termination is desirable. This can be achieved with a "Star" connection.

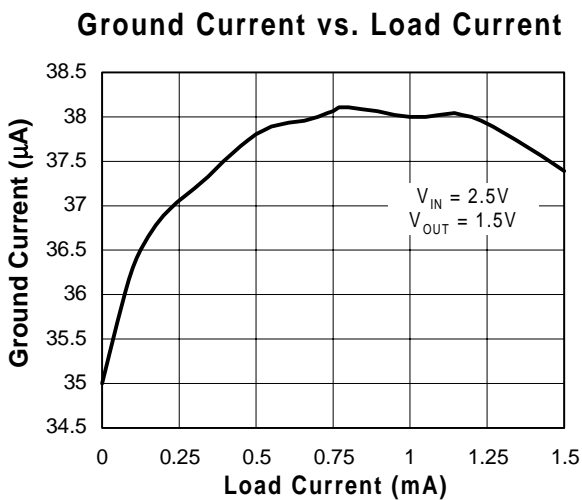
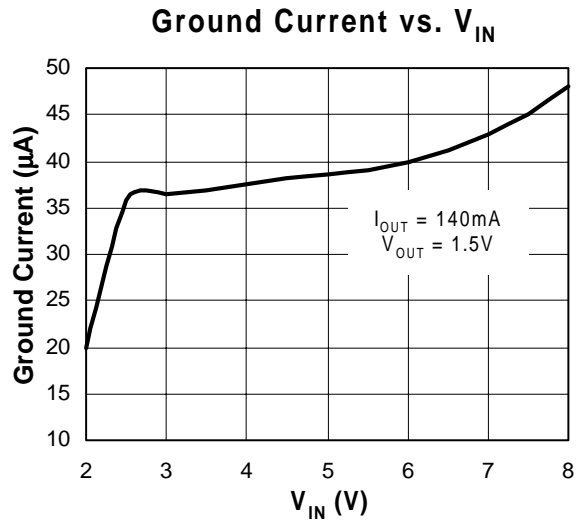
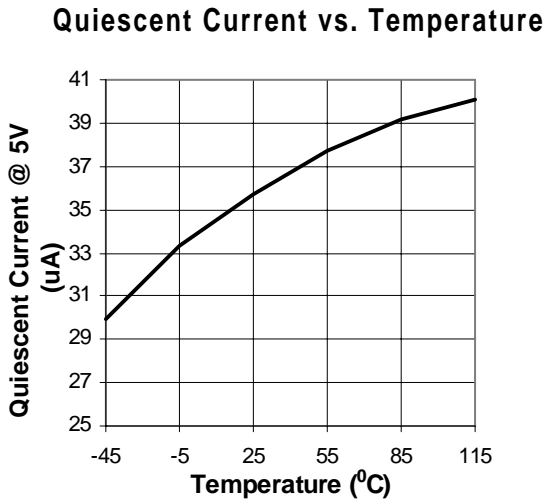
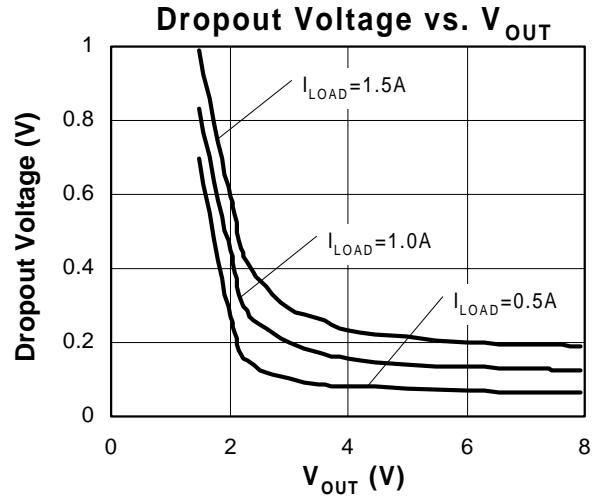
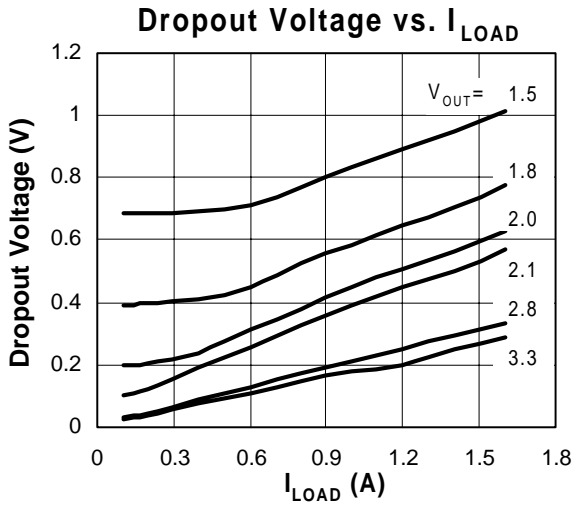

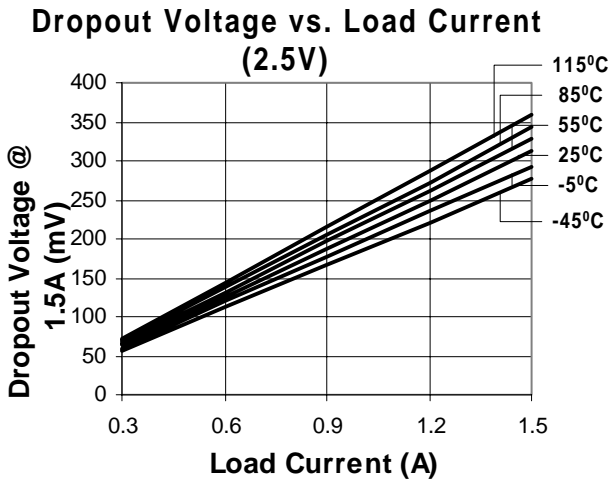
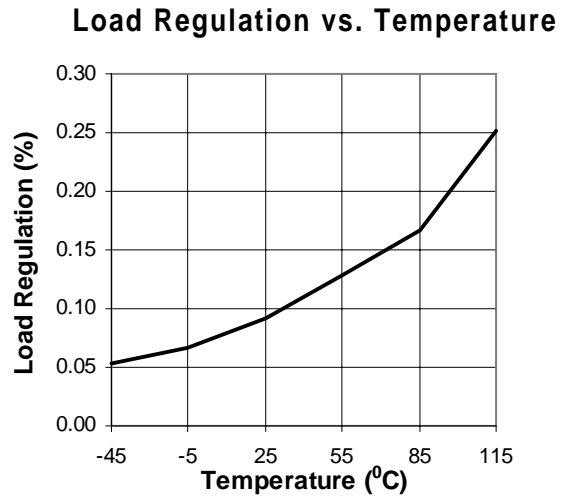
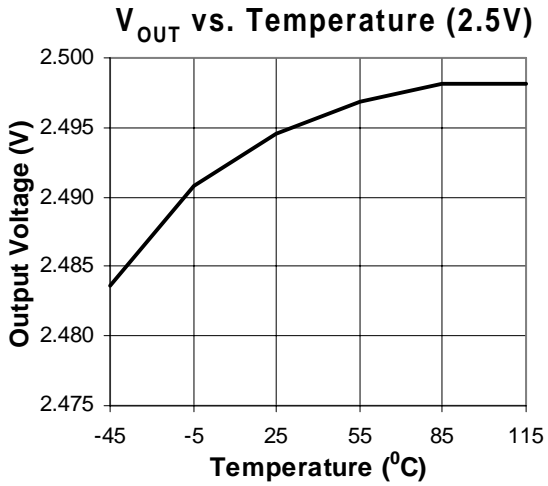

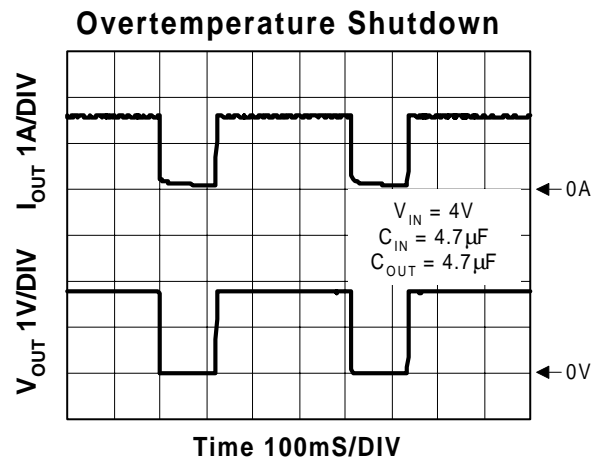
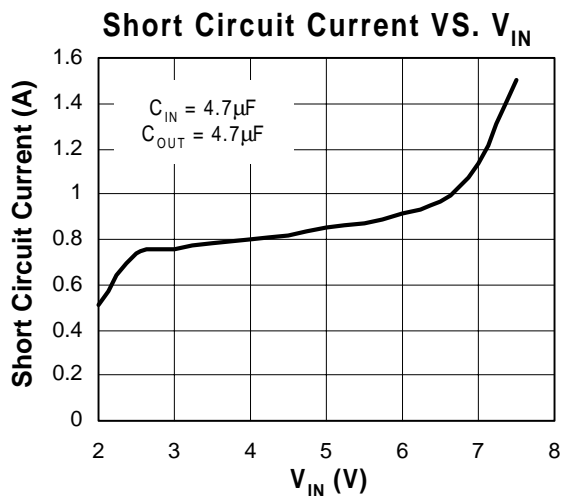
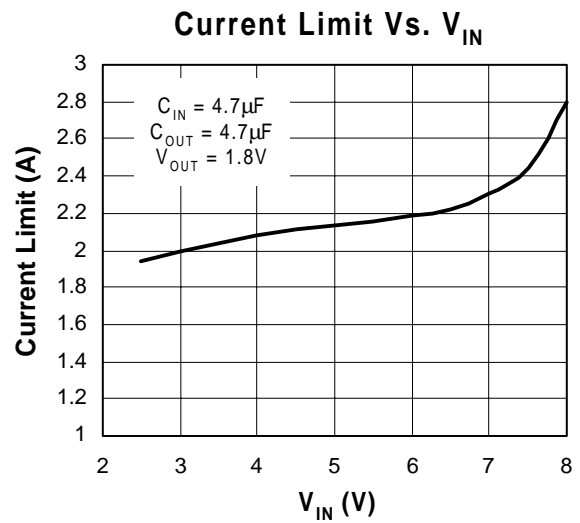
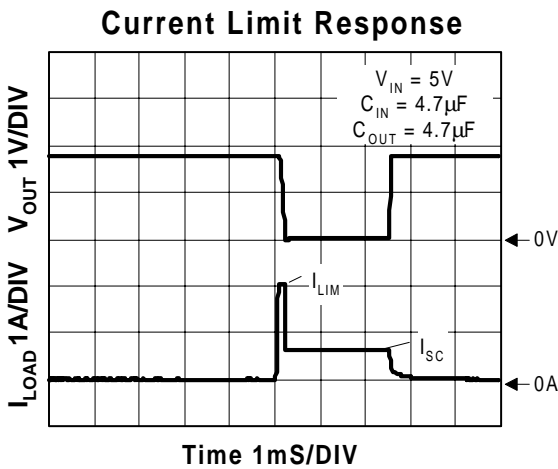
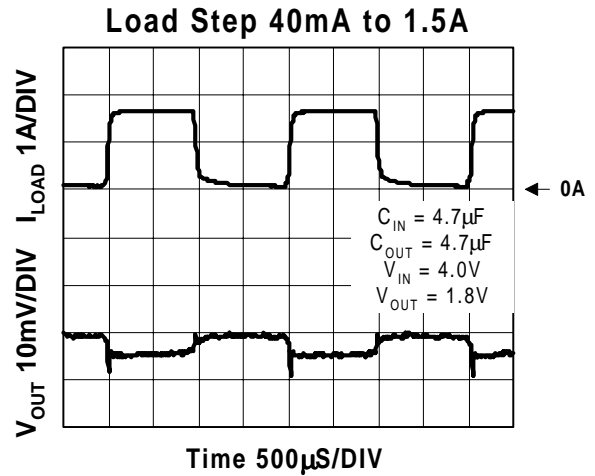
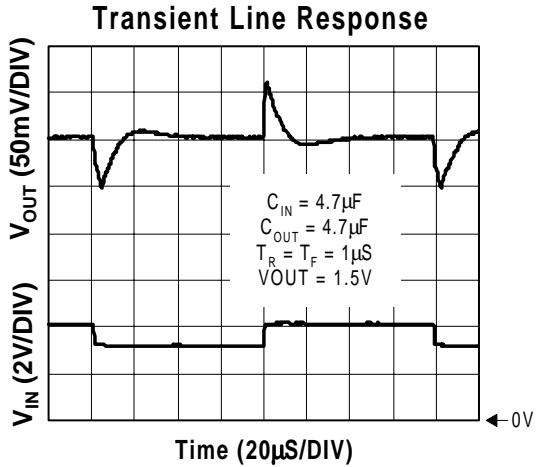

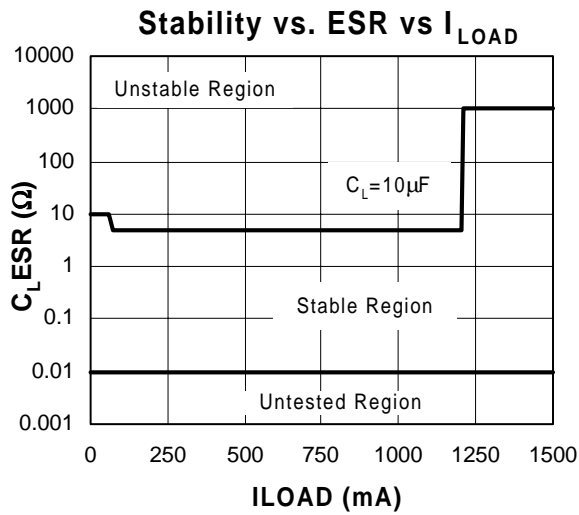
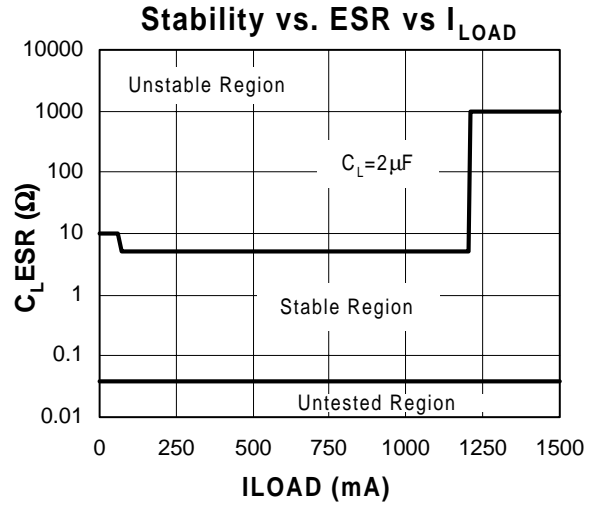
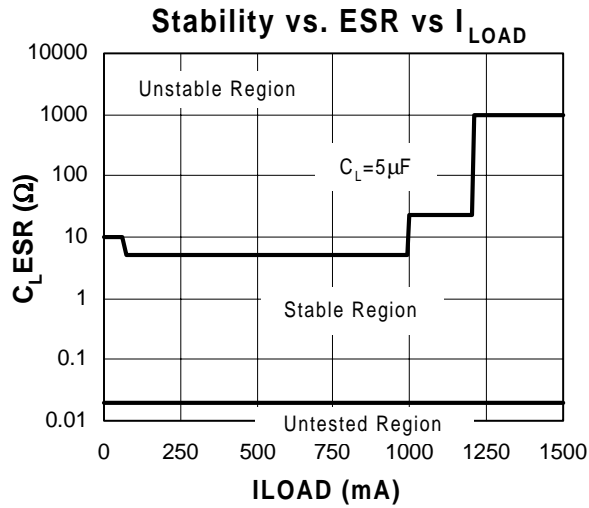



■ Package Dimension

TO-220

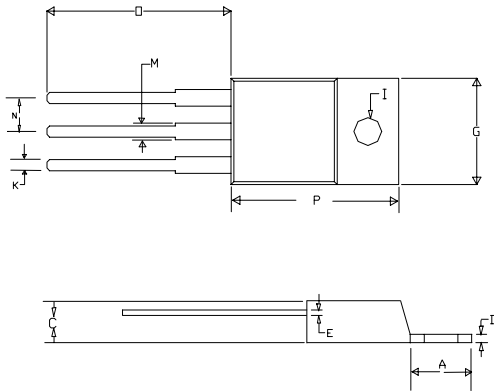

SYMBOLS	MILLIMETERS		INCHES	
	MIN	MAX	MIN	MAX
A	5.58	7.49	0.2197	0.2949
C	3.56	4.83	0.1400	0.1900
D	0.51	1.40	0.0200	0.0550
E	0.31	1.14	0.0120	0.0450
G	9.65	10.67	0.3800	0.4200
I	3.53	4.09	0.1390	0.1610
K	0.51	1.14	0.0200	0.0450
M	1.14	1.78	0.0449	0.0700
N	2.29	2.79	0.0900	0.1100
O	12.70	14.73	0.5000	0.5800
P	14.22	16.51	0.5600	0.6500

SOT-223

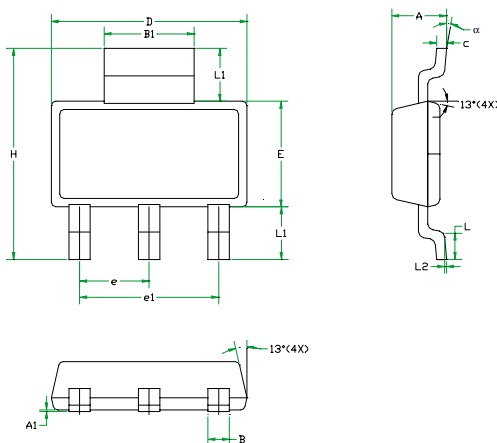

SYMBOLS	MILLIMETERS		INCHES	
	MIN	MAX	MIN	MAX
A	1.50	1.80	0.0591	0.0709
A ₁	0.02	0.10	0.0008	0.0039
B	0.60	0.84	0.0236	0.0330
B ₁	2.90	3.15	0.1140	0.1240
C	0.24	0.38	0.0094	0.0150
D	6.30	6.71	0.2480	0.2640
E	3.30	3.71	0.1299	0.1460
e	2.30 BSC		0.0906 BSC	
e ₁	4.60 BSC		0.1811 BSC	
H	6.70	7.30	0.2638	0.2874
L	0.91 MIN		0.0358 MIN	
L ₁	2.00 MAX		0.0787 MAX	
L ₂	0.06 BSC		0.0024 BSC	
a	0°	10°	0°	10°



Package Dimension

TO-252

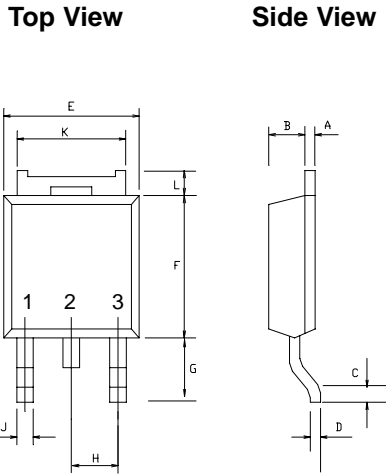

SYMBOLS	MILLIMETERS		INCHES	
	MIN	MAX	MIN	MAX
A	0.40	0.60	0.0157	0.0236
B	1.60	2.00	0.0630	0.0787
C	0.50	-	0.0197	-
D	0.40	0.60	0.0157	0.0236
E	6.35	6.80	0.2500	0.2677
F	5.33	6.30	0.2098	0.2480
G	2.20	3.00	0.0866	0.1181
H	1.98	2.50	0.0780	0.0984
J	0.61	0.97	0.0240	0.0382
K	5.04	5.64	0.1984	0.2220
L	0.40	2.03	0.0157	0.0799

* : Typical value

NOTES :

1. CONTROLLING DIMENSION : MILLIMETERS.
2. MAXIMUM LEAD THICKNESS INCLUDES LEAD FINISH THICKNESS
MINIMUM LEAD THICKNESS IS THE MINIMUM THICKNESS OF BASE MATERIAL.

Or

TO-252

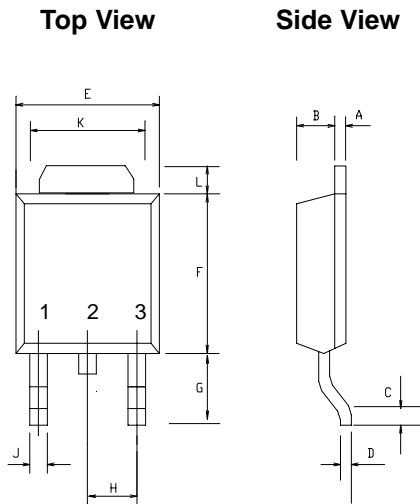

SYMBOLS	MILLIMETERS		INCHES	
	MIN	MAX	MIN	MAX
A	0.40	0.60	0.0157	0.0236
B	1.60	2.00	0.0630	0.0787
C	0.50	-	0.0197	-
D	0.40	0.60	0.0157	0.0236
E	6.35	6.80	0.2500	0.2677
F	5.33	6.30	0.2098	0.2480
G	2.20	3.00	0.0866	0.1181
H	1.98	2.50	0.0780	0.0984
J	0.61	0.97	0.0240	0.0382
K	5.04	5.64	0.1984	0.2220
L	0.40	2.03	0.0157	0.0799

* : Typical value

NOTES :

1. CONTROLLING DIMENSION : MILLIMETERS.
2. MAXIMUM LEAD THICKNESS INCLUDES LEAD FINISH THICKNESS
MINIMUM LEAD THICKNESS IS THE MINIMUM THICKNESS OF BASE MATERIAL.



www.ame.com.tw
E-Mail: info@ame.com.tw

Life Support Policy:

These products of AME, Inc. are not authorized for use as critical components in life-support devices or systems, without the express written approval of the president of AME, Inc.

AME, Inc. reserves the right to make changes in the circuitry and specifications of its devices and advises its customers to obtain the latest version of relevant information.

© AME, Inc. , January 2002

Document: 2013-DS8815-E

U.S. Headquarters
Analog Microelectronics, Inc.

3100 De La Cruz Blvd. Suite 201
Santa Clara, CA. 95054-2046
Tel : (408) 988-2388
Fax: (408) 988-2489

Corporate Headquarters
AME, Inc.

2F, 189 Kang-Chien Road, Nei-Hu District
Taipei 114, Taiwan, R.O.C.
Tel : 886 2 2627-8687
Fax: 886 2 2659-2989