

August 2010

FD2000

(LCD Display Driver)

USER'S MANUAL

REVISION 1.0

CONTENTS

1. OVERVIEW	4
2. FEATURES.....	4
3. BLOCK DIAGRAM.....	5
4. PIN ASSIGNMENTS.....	6
4.1. 80-MQFP-1420	6
4.2. 80-LQFP-1212	7
5. PIN DESCRIPTIONS.....	8
6. BLOCK FUNCTIONS.....	9
6.1. AC (Address counter).....	9
6.2. DCRAM (Data control RAM)	9
6.3. ADRAM (Additional data RaM)	10
6.4. CGROM (Character generator ROM)	11
6.5. CGRAM (Character generator RAM)	11
7. RESET FUNCTION	12
8. SERIAL DATA TRANSFER FORMAT.....	13
9. INSTRUCTION TABLE.....	14
10. DETAILED INSTRUCTION DESCRIPTIONS	15
10.1. Set display technique — Sets the display technique.....	15
10.2. Display on/off control — Turns the display on or off.....	15
10.3. Display shift — Shifts the display.....	16
10.4. Set AC address — Specifies the DCRAM and ADRAM address for AC.....	17
10.5. DCRAM data write — Specifies the DCRAM address and stores data at that address.....	17
10.6. ADRAM data write — Specifies the ADRAM address and stores data at that address.....	19
10.7. CGRAM data write — Specifies the CGRAM address and stores data at that address.....	21
11. NOTES ON THE POWER ON AND POWER OFF SEQUENCES	22
12. LCD DRIVE TECHNIQUE	23
12.1. 1/8 duty, 1/4 bias drive technique	23
12.2. 1/9 duty, 1/4 bias drive technique	24
12.3. 1/10 duty, 1/4 bias drive technique	25
13. SAMPLE APPLICATION CIRCUIT.....	26
13.1. 1/8 duty, 1/4 bias drive (For use with normal panels).....	26
13.2. 1/8 duty, 1/4 bias drive (For use with large panels).....	26
13.3. 1/9 duty, 1/4 bias drive (For use with normal panels).....	27
13.4. 1/9 duty, 1/4 bias drive (For use with large panels).....	27
13.5. 1/10 duty, 1/4 bias drive (For use with normal panels).....	28
13.6. 1/10 duty, 1/4 bias drive (For use with large panels).....	28

14. SAMPLE CORRESPONDENCE BETWEEN INSTRUCTIONS AND THE DISPLAY	29
15. FD2000 CHARACTER FONT (STANDARD)	31
16. ELECTRICAL CHARACTERISTICS	32
16.1. Absolute maximum ratings.....	32
16.2. Allowable operating ranges.....	33
16.3. Electrical characteristics in the allowable operating ranges	34
17. PACKAGE DIMENSIONS.....	36
17.1. 80-MQFP-1420	36
17.2. 80-LQFP-1212	37

1. OVERVIEW

The FD2000 is 1/8 to 1/10 duty dot matrix LCD display controller/drivers that supports the display of characters, numbers, and symbols. In addition to generating dot matrix LCD drive signals based on data transferred serially from a microcontroller, the FD2000 also provide on-chip character display ROM and RAM to allow display systems to be implemented easily.

2. FEATURES

- **Controls and drives a 5 x 7, 5 x 8, or 5 x 9 dot matrix LCD.**
- **Supports accessory display segment drive (up to 60 segments)**
- **Display technique**
 - 1/8 duty 1/4 bias drive (5 x 7 dots)
 - 1/9 duty 1/4 bias drive (5 x 8 dots)
 - 1/10 duty 1/4 bias drive (5 x 9 dots)
- **Display digits**
 - 12 digits x 1 line (5 x 7 dots)
 - 11 digits x 1 line (5 x 8 or 5 x 9 dots)
- **Display control memory**
 - CGROM: 240 characters (5 x 7, 5 x 8, or 5 x 9 dots)
 - CGRAM: 16 characters (5 x 7, 5 x 8, or 5 x 9 dots)
 - ADRAM: 12 x 5 bits
 - DCRAM: 48 x 8 bits
- **Instruction function**
 - Display on/off control
 - Display shift function
- **Provides a backup function based on low power modes**
- **Serial data input support**
- **Independent LCD drive block power supply VLCD**
- **Provides a RESETB pin for LSI internal initialization**
- **RC oscillator circuit**

3. BLOCK DIAGRAM

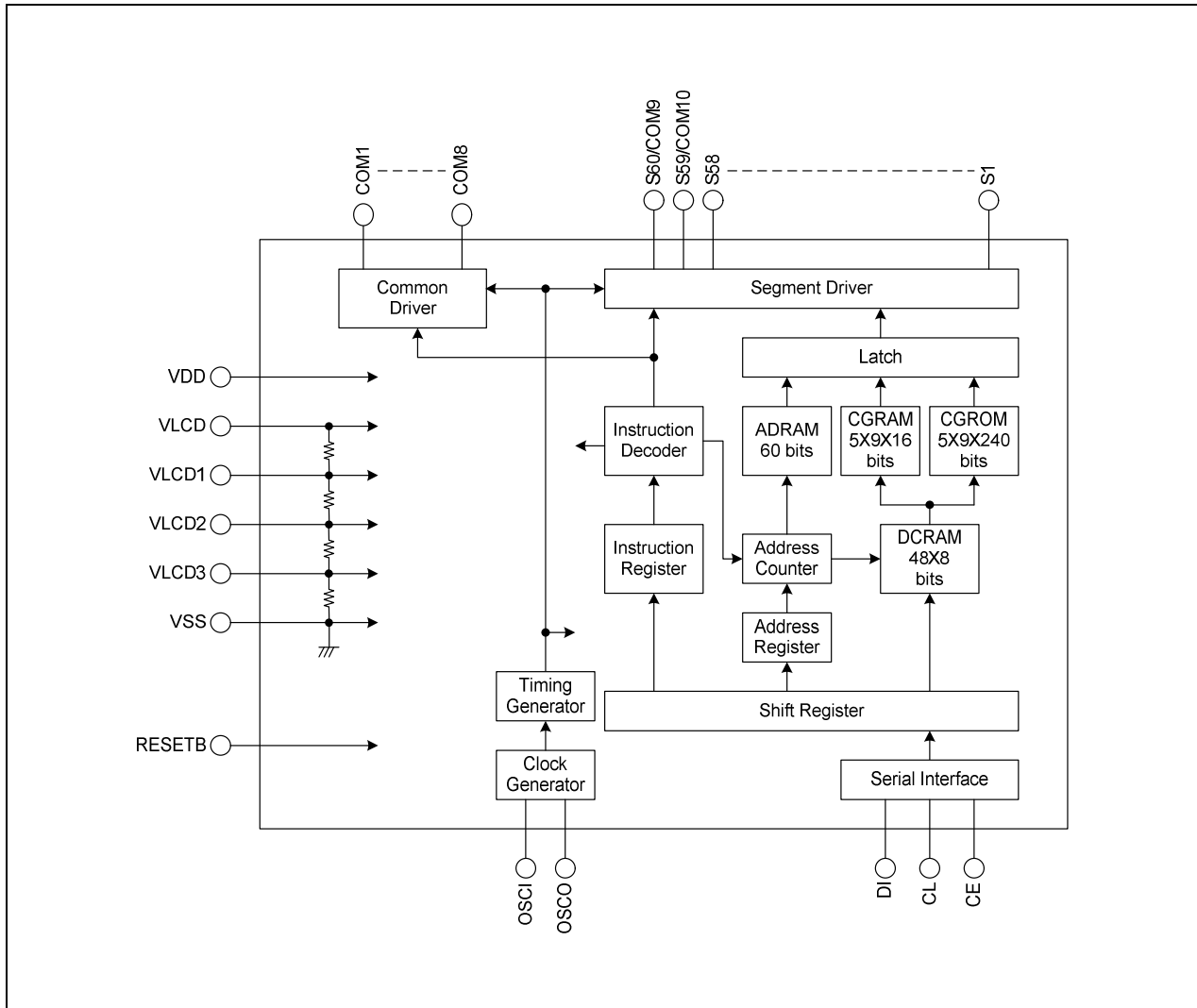

4. PIN ASSIGNMENTS

4.1. 80-MQFP-1420

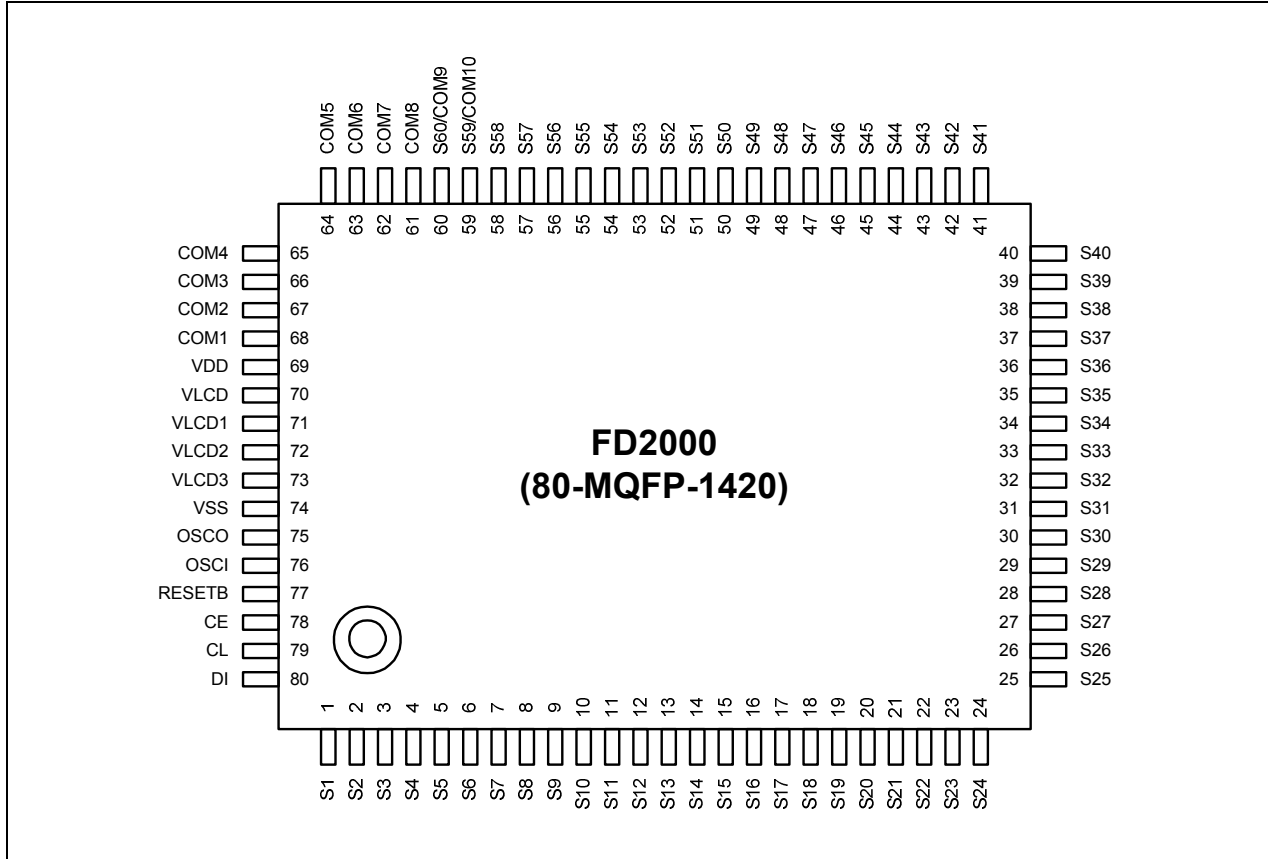

4.2. 80-LQFP-1212

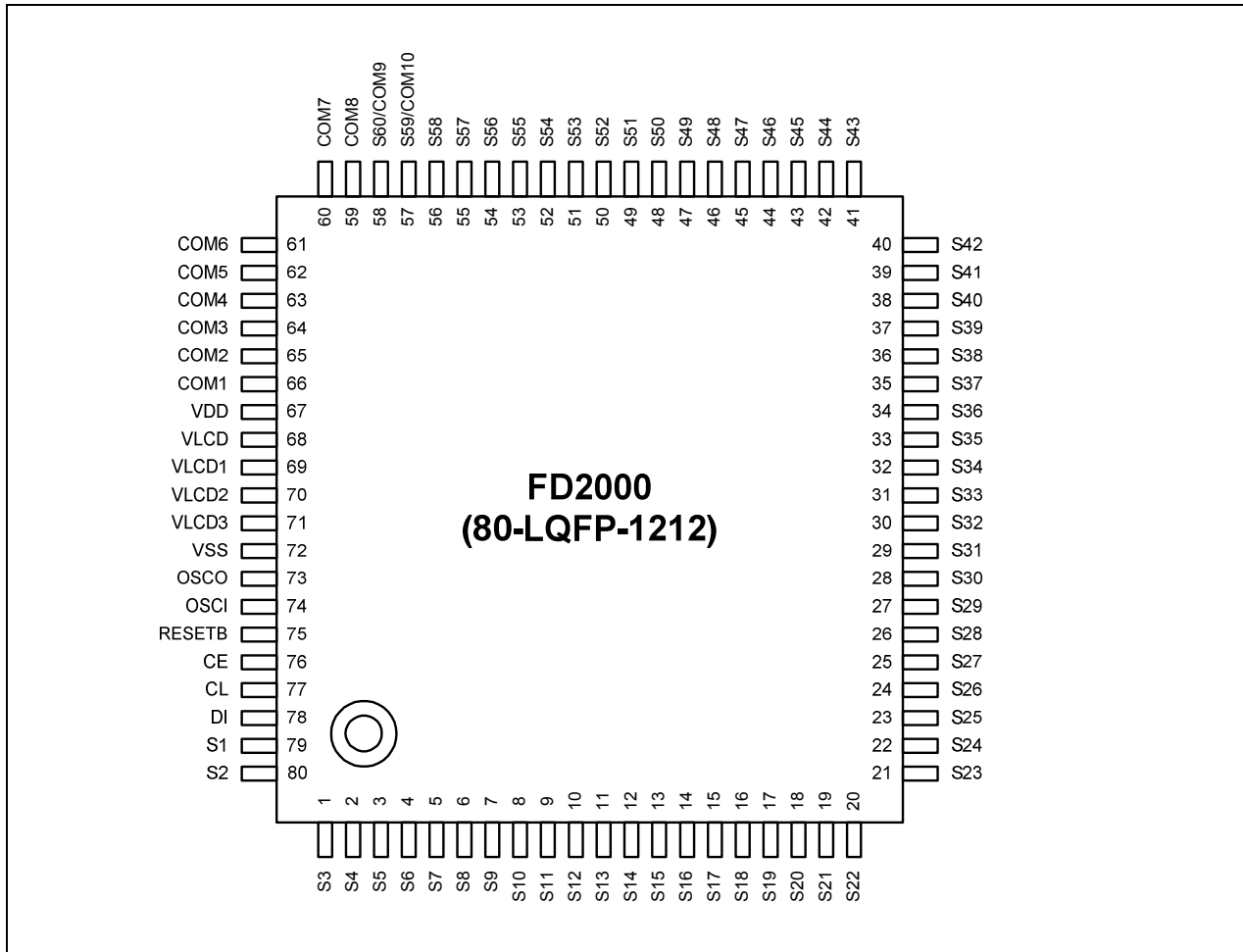

5. PIN DESCRIPTIONS

Pin Names	Pin No.	Pin Description	Active	I/O	Handling when unused	
S1-S58 S59/COM10 S60/COM9	1-58 (79,80, 1-56) 59(57) 60(58)	Segment driver outputs. The S59/COM10 and S60/COM9 pins can be used as common driver outputs under the "set display technique" instruction.	-	O	Open	
COM1-COM8	68-61 (66-59)	Common driver outputs.	-	O	Open	
OSCI	76(74)	Oscillator connections. An oscillator circuit is formed by connecting an external resistor and capacitor at these pins.	-	I	GND	
OSCO	75(73)		-	O	Open	
CE	78(76)	Serial data transfer inputs. These pins are connected to the microcontroller.	Chip enable	H	I	GND
CL	79(77)		Synchronization clock		I	
DI	80(78)		Transfer data	-	I	
RESETB	77(75)	Reset signal input. <ul style="list-style-type: none"> • When RESETB is low (V_{SS}): <ul style="list-style-type: none"> • Display off <ul style="list-style-type: none"> S1 to S58 = "L" (V_{SS}). S59/COM10 and S60/COM9 = "L" (V_{SS}). COM1 to COM8 = "L" (V_{SS}). • Serial data transfer is disabled. • The OSCI/OSCO pin oscillator is stopped. • When RESETB is high (V_{DD}): <ul style="list-style-type: none"> • Display on after a "display on/off control" (display on state setting) instruction is executed. • Serial data transfers are enabled. • The OSCI/OSCO pin oscillator operates. 	L	I	GND	
V _{LCD1}	71(69)	Used for applying the LCD drive 3/4 bias voltage externally.	-	I	Open	
V _{LCD2}	72(70)	Used for applying the LCD drive 2/4 bias voltage externally.	-	I	Open	
V _{LCD3}	73(71)	Used for applying the LCD drive 1/4 bias voltage externally.	-	I	Open	
V _{DD}	69(67)	Logic block power supply connection. Provide a voltage of between 2.7 and 6.0 V.	-	-	-	
V _{LCD}	70(68)	LCD driver block power supply connection. Provide a voltage of between 4.5 and 10.0 V.	-	-	-	
V _{SS}	74(72)	Power supply connection. Connect to ground.	-	-	-	

NOTE: Parentheses indicate pin number for 80-LQFP-1212 package.

6. BLOCK FUNCTIONS

6.1. AC (ADDRESS COUNTER)

AC is a counter that provides the addresses used for DCRAM and ADRAM. The address is automatically modified internally, and the LCD display state is retained.

6.2. DCRAM (DATA CONTROL RAM)

DCRAM is RAM that is used to store display data expressed as 8-bit character codes. (These character codes are converted to 5 x 7, 5 x 8, or 5 x 9 dot matrix character patterns using CGROM or CGRAM.) DCRAM has a capacity of 48 x 8 bits, and can hold 48 characters. The table below lists the correspondence between the 6-bit DCRAM address loaded into AC and the display position on the LCD panel.

- When the DCRAM address loaded into AC is 00H.

Display digit	1	2	3	4	5	6	7	8	9	10	11	12
DCRAM address(HEX)	00	01	02	03	04	05	06	07	08	09	0A	0B

However, when the display shift is performed by specifying MDATA, the DCRAM address shifts as shown below.

Display digit	1	2	3	4	5	6	7	8	9	10	11	12
DCRAM address(HEX)	01	02	03	04	05	06	07	08	09	0A	0B	0C

(Left shift)

Display digit	1	2	3	4	5	6	7	8	9	10	11	12
DCRAM address(HEX)	2F	00	01	02	03	04	05	06	07	08	09	0A

(Right shift)

NOTE: The DCRAM addresses are expressed in hexadecimal.

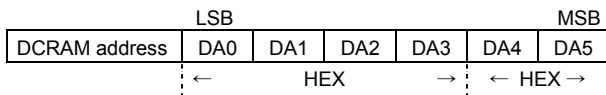

- Example: When the DCRAM address is 2EH.

	LSB					MSB
DA0	DA1	DA2	DA3	DA4	DA5	
0	1	1	1	0	1	

NOTE: 5 x 7 dots ... 12-digit display 5 x 7 dots
 5 x 8 dots ... 12-digit display 4 x 8 dots
 5 x 9 dots ... 12-digit display 3 x 9 dots

6.3. ADRAM (ADDITIONAL DATA RAM)

ADRAM is RAM used to store the ADATA display data. ADRAM has a capacity of 12 x 5 bits, and the stored display data is displayed directly without the use of CGROM or CGRAM. The table below lists the correspondence between the 4-bit ADRAM address loaded into AC and the display position on the LCD panel.

- When the ADRAM address loaded into AC is 0H. (Number of digit displayed: 12)

Display digit	1	2	3	4	5	6	7	8	9	10	11	12
ADRAM address(HEX)	0	1	2	3	4	5	6	7	8	9	A	B

However, when the display shift is performed by specifying ADATA, the ADRAM address shifts as shown below.

Display digit	1	2	3	4	5	6	7	8	9	10	11	12
ADRAM address(HEX)	1	2	3	4	5	6	7	8	9	A	B	0

(Left shift)

Display digit	1	2	3	4	5	6	7	8	9	10	11	12
ADRAM address(HEX)	B	0	1	2	3	4	5	6	7	8	9	A

(Right shift)

NOTE: The ADRAM addresses are expressed in hexadecimal.

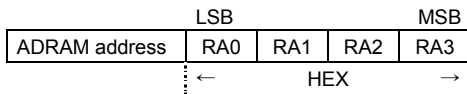

- Example: When the ADRAM address is AH.

	LSB			MSB
RA0	RA1	RA2	RA3	
0	1	0	1	

NOTE: 5 x 7 dots ... 12-digit display 5 dots
 5 x 8 dots ... 12-digit display 4 dots
 5 x 9 dots ... 12-digit display 3 dots

6.4. CGROM (CHARACTER GENERATOR ROM)

CGROM is ROM used to generate the 240 kinds of 5 x 7, 5 x 8, or 5 x 9 dot matrix character patterns from the 8-bit character codes. CGROM has a capacity of 240 x 45 bits. When a character code is written to DCRAM, the character pattern stored in CGROM corresponding to the character code is displayed at the position on the LCD corresponding to the DCRAM address loaded into AC.

6.5. CGRAM (CHARACTER GENERATOR RAM)

CGRAM is RAM to which user programs can freely write arbitrary character patterns. Up to 16 kinds of 5 x 7, 5 x 8, or 5 x 9 dot matrix character patterns can be stored. CGRAM has a capacity of 16 x 45 bits.

7. RESET FUNCTION

The FD2000 is reset when a low level is applied to the RESETB pin at power on and, in normal mode. On a reset the FD2000 create a display with all LCD panels turned off. However, after a reset applications must set the contents of DGRAM, ADRAM, and CGRAM before turning on display with a “display on/off control” instruction since the contents of these memories are undefined. That is, applications must execute the following instructions.

- Set display technique
- DGRAM data write
- ADRAM data write (If ADRAM is used.)
- CGRAM data write (If CGRAM is used.)
- Set AC address

After executing the above instructions, applications must turn on the display with a “display on/off control” instruction. Note that when applications turn off in the normal mode, applications must turn off the display with a “display on/off control” instruction. (See the detailed instruction descriptions.)

8. SERIAL DATA TRANSFER FORMAT

- When CL is stopped at the low level

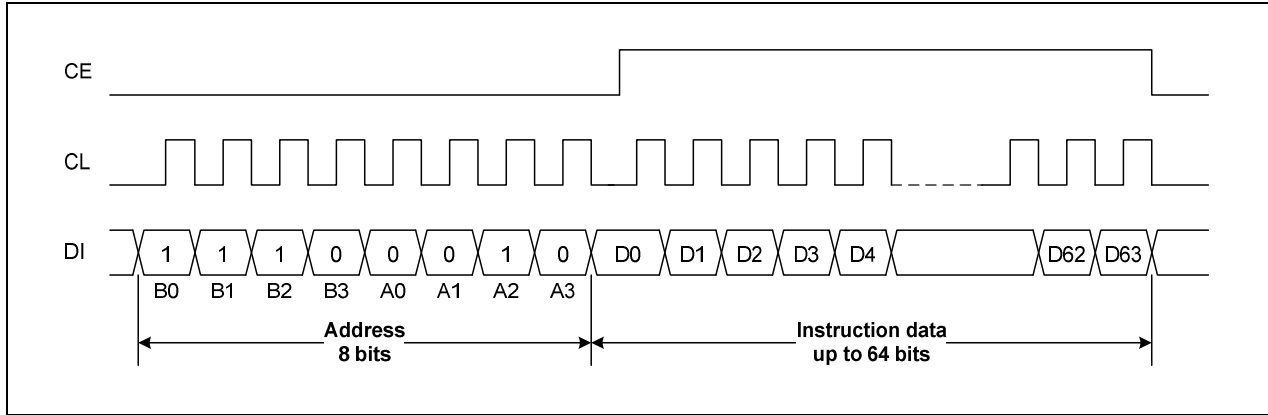

- When CL is stopped at the high level

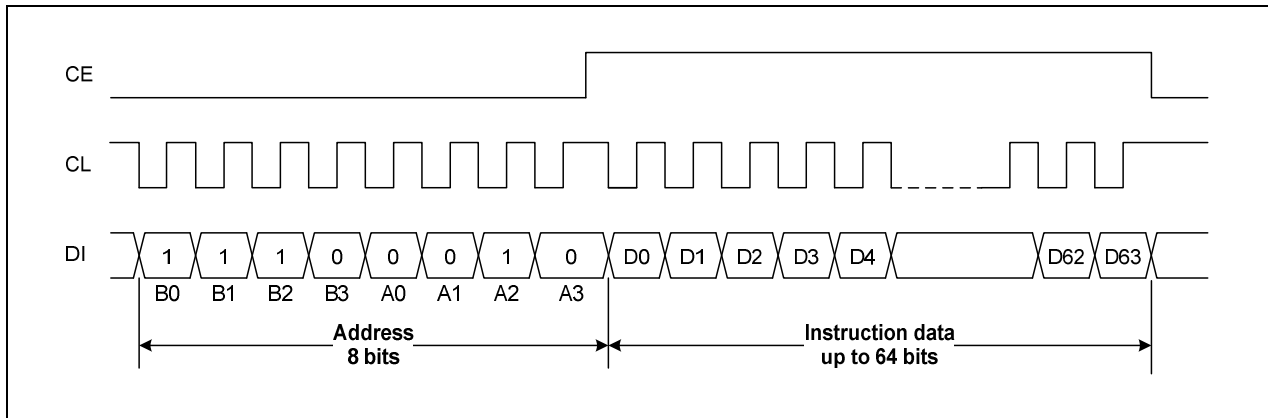

- Address: 47H
- D0 to D63: Instruction data

The data is acquired on the rising edge of the CL signal and latched on the falling edge of the CE signal. When transferring instruction data from the microcontroller, applications must assure that the time from the transfer of one set of instruction data until the next instruction data transfer is significantly longer than the instruction execution time.

9. INSTRUCTION TABLE

Instruction	D0	D1	...	D39	D40	D41	D42	D43	D44	D45	D46	D47	D48	D49	D50	D51	D52	D53	D54	D55	D56	D57	D58	D59	D60	D61	D62	D63	Execution time NOTES
Set display technique																					DT1	DT2	X	X	0	0	0	1	0us
Display on/off control					DG1	DG2	DG3	DG4	DG5	DG6	DG7	DG8	DG9	DG10	DG11	DG12	X	X	X	X	M	A	SC	BU	0	0	1	0	0us/27us NOTE4
Display shift																					M	A	R/L	X	0	0	1	1	27us
Set AC address													DA0	DA1	DA2	DA3	DA4	DA5	X	X	RA0	RA1	RA2	RA3	0	1	0	0	27us
DCRAM data write NOTE1					AC0	AC1	AC2	AC3	AC4	AC5	AC6	AC7	DA0	DA1	DA2	DA3	DA4	DA5	X	X	IM	X	X	X	0	1	0	1	27us
ADRAM data write NOTE2					AD1	AD2	AD3	AD4	AD5	X	X	X	RA0	RA1	RA2	RA3	X	X	X	X	IM	X	X	X	0	1	1	0	27us
CGRAM data write	CD1	CD2	...	CD40	CD41	CD42	CD43	CD44	CD45	X	X	X	CA0	CA1	CA2	CA3	CA4	CA5	CA6	CA7	X	X	X	X	0	1	1	1	27us

X: don't care

NOTES:

1. The data format differs when the "DCRAM data write" instruction is executed in the increment mode (IM = 1). (See detailed instruction descriptions.)
2. The data format differs when the "ADRAM data write" instruction is executed in the increment mode (IM = 1). (See detailed instruction descriptions.)
3. The execution times listed here apply when fosc = 300 kHz. The execution times differ when the oscillator frequency fosc differs.
Example: When fosc = 210 kHz

$$27 \mu s \times \frac{300}{210} = 39 \mu s$$

4. When the power saving mode (BU = 1) is set, the execution time is 27 μs (when fosc = 300 kHz).

10. DETAILED INSTRUCTION DESCRIPTIONS

10.1. SET DISPLAY TECHNIQUE — Sets the display technique

Code							
D56	D57	D58	D59	D60	D61	D62	D63
DT1	DT2	X	X	0	0	0	1

X: don't care

10.1.1. DT1, DT2: Setting the display technique

DT1	DT2	Display technique	Output pins	
			S60/COM9	S59/COM10
0	0	1/8 duty, 1/4 bias drive	S60	S59
1	0	1/9 duty, 1/4 bias drive	COM9	S59
0	1	1/10 duty, 1/4 bias drive	COM9	COM10

10.2. DISPLAY ON/OFF CONTROL — Turns the display on or off

Code																							
D40	D41	D42	D43	D44	D45	D46	D47	D48	D49	D50	D51	D52	D53	D54	D55	D56	D57	D58	D59	D60	D61	D62	D63
DG1	DG2	DG3	DG4	DG5	DG6	DG7	DG8	DG9	DG10	DG11	DG12	X	X	X	X	M	A	SC	BU	0	0	1	0

X: don't care

10.2.1. M, A: Specifies the data to be turned on or off

M	A	Display operating state
0	0	Both MDATA and ADATA are turned off (The display is forcibly turned off regardless of the DG1 to DG12 data.)
0	1	Only ADATA is turned on (The ADATA of display digits specified by the DG1 to DG12 data are turned on.)
1	0	Only MDATA is turned on (The MDATA of display digits specified by the DG1 to DG12 data are turned on.)
1	1	Both MDATA and ADATA are turned on (The MDATA and ADATA of display digits specified by the DG1 to DG12 data are turned on.)

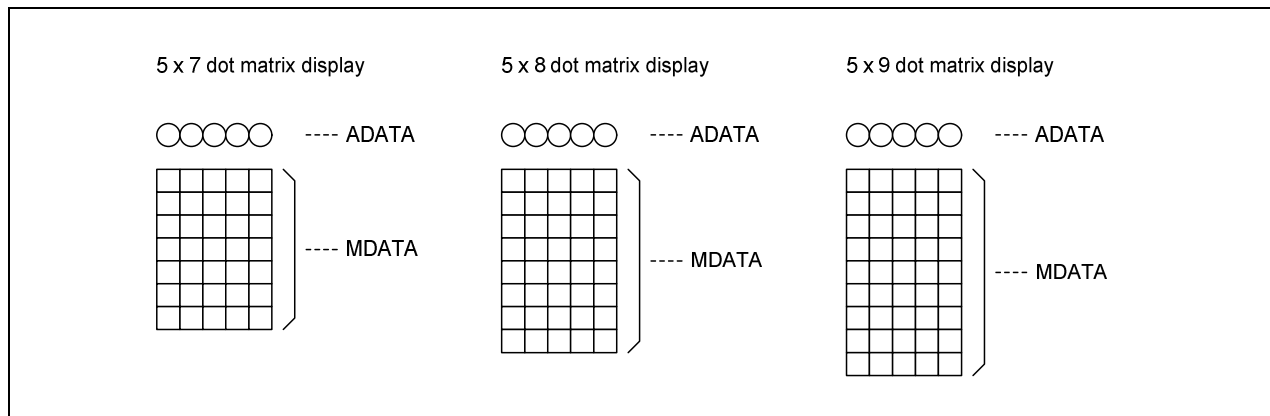

10.2.2. DG1 to DG12: Specifies the display digit

Display digit	1	2	3	4	5	6	7	8	9	10	11	12
Display digit data	DG1	DG2	DG3	DG4	DG5	DG6	DG7	DG8	DG9	DG10	DG11	DG12

For example, if DG1 to DG6 are 1, and DG7 to DG12 are 0, then display digits 1 to 6 will be turned on, and display digits 7 to 12 will be turned off (blanked).

10.2.3. SC: Controls the common and segment output pins

SC	Common and segment output pin states
0	Output of LCD drive waveforms
1	Fixed at the VSS level (all segments off)

NOTE: When SC is 1, the S1 to S60 and COM1 to COM10 output pins are set to the VSS level, regardless of the M, A, and DG1 to DG12 data.

10.2.4. BU: Controls the normal mode and power saving mode

BU	Mode
0	Normal mode
1	Power saving mode (In this mode, the OSC1 and OSC0 pins oscillator is stopped, and the common and segment pins are set to the VSS level. In this mode, instructions other than the "display on/off control" instruction cannot be executed. Thus applications must set the LSI to normal mode before executing any of the other instructions.)

10.3. DISPLAY SHIFT — Shifts the display

Code							
D56	D57	D58	D59	D60	D61	D62	D63
M	A	R/L	X	0	0	1	1

X: don't care

10.3.1. M, A: Specifies the data to be shifted

M	A	Shift operating state
0	0	Neither MDATA nor ADATA is shifted
0	1	Only ADATA is shifted
1	0	Only MDATA is shifted
1	1	Both MDATA and ADATA are shifted

10.3.2. R/L: Shift direction specification

R/L	Shift direction
0	Left shift
1	Right shift

10.4. SET AC ADDRESS — Specifies the DCRAM and ADRAM address for AC

Code															
D48	D49	D50	D51	D52	D53	D54	D55	D56	D57	D58	D59	D60	D61	D62	D63
DA0	DA1	DA2	DA3	DA4	DA5	X	X	RA0	RA1	RA2	RA3	0	1	0	0

X: don't care

10.4.1. DA0 to DA5: DCRAM address

DA0	DA1	DA2	DA3	DA4	DA5
LSB				MSB	

10.4.2. RA0 to RA3: ADRAM address

RA0	RA1	RA2	RA3
LSB		MSB	

This instruction loads the 6-bit DCRAM address DA0 to DA5 and the 4-bit ADRAM address RA0 to RA3 into the AC.

10.5. DCRAM DATA WRITE — Specifies the DCRAM address and stores data at that address

Code																							
D40	D41	D42	D43	D44	D45	D46	D47	D48	D49	D50	D51	D52	D53	D54	D55	D56	D57	D58	D59	D60	D61	D62	D63
AC0	AC1	AC2	AC3	AC4	AC5	AC6	AC7	DA0	DA1	DA2	DA3	DA4	DA5	X	X	IM	X	X	X	0	1	0	1

X: don't care

10.5.1. DA0 to DA5: DCRAM address

DA0	DA1	DA2	DA3	DA4	DA5
LSB				MSB	

10.5.2. AC0 to AC7: DCRAM data (character code)

AC0	AC1	AC2	AC3	AC4	AC5	AC6	AC7
LSB				MSB			

This instruction writes the 8 bits of data AC0 to AC7 to DCRAM. This data is a character code, and is converted to a 5 x 7, 5 x 8, or 5 x 9 dot matrix display data using CGROM or CGRAM.

10.5.3. IM: Setting the method of writing data to DCRAM

IM	DCRAM data write method
0	Normal DCRAM data write (Specifies the DCRAM address and writes the DCRAM data.)
1	Increment mode DCRAM data write (Increments the DCRAM address by +1 each time data is written to DCRAM.)

- DCRAM data write method when IM = 0

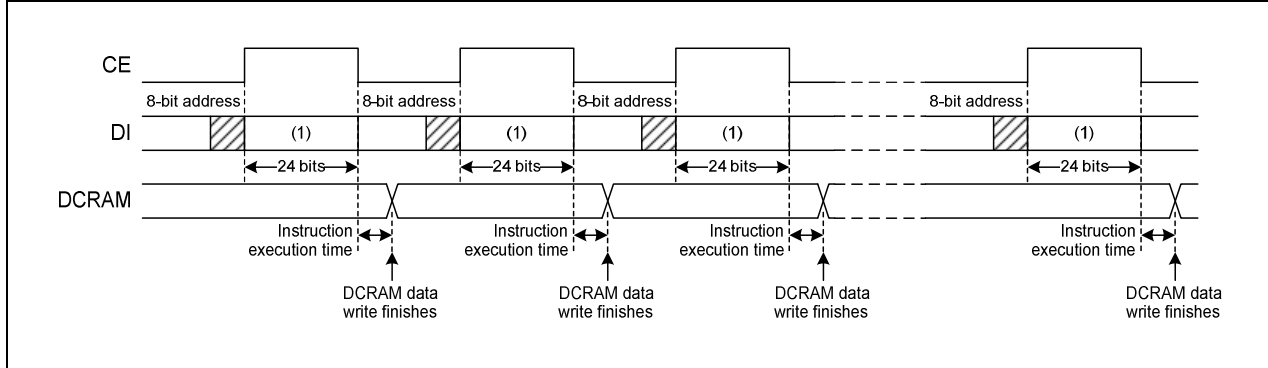

- DCRAM data write method when IM = 1 (Instructions other than the "DCRAM data write" instruction cannot be executed.)

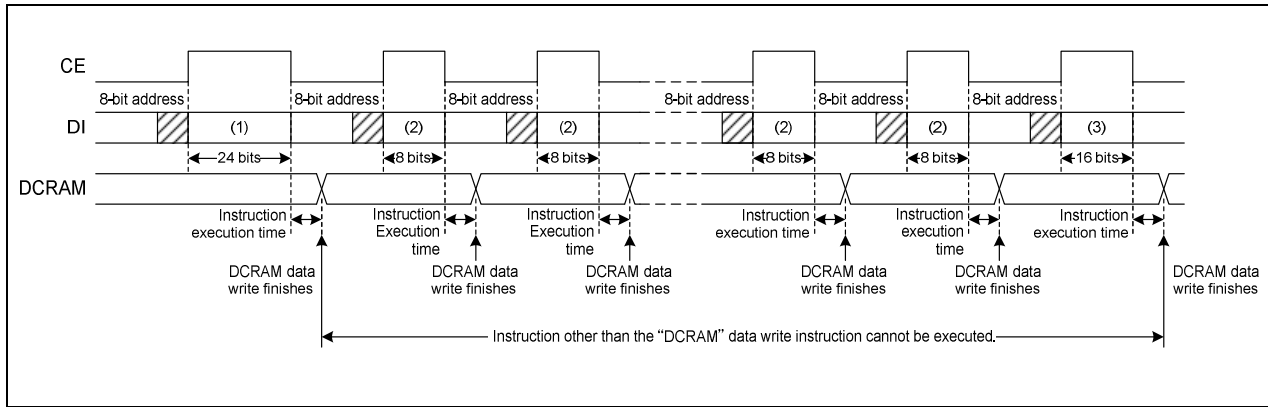

10.5.4. Data format at (1) (24 bits)

Code																							
D40	D41	D42	D43	D44	D45	D46	D47	D48	D49	D50	D51	D52	D53	D54	D55	D56	D57	D58	D59	D60	D61	D62	D63
AC0	AC1	AC2	AC3	AC4	AC5	AC6	AC7	DA0	DA1	DA2	DA3	DA4	DA5	X	X	IM	X	X	X	0	1	0	1

X: don't care

10.5.5. Data format at (2) (8 bits)

Code							
D56	D57	D58	D59	D60	D61	D62	D63
AC0	AC1	AC2	AC3	AC4	AC5	AC6	AC7

10.5.6. Data format at (3) (16 bits)

Code															
D48	D49	D50	D51	D52	D53	D54	D55	D56	D57	D58	D59	D60	D61	D62	D63
AC0	AC1	AC2	AC3	AC4	AC5	AC6	AC7	0	X	X	X	0	1	0	1

X: don't care

10.6. ADRAM DATA WRITE — Specifies the ADRAM address and stores data at that address

Code																							
D40	D41	D42	D43	D44	D45	D46	D47	D48	D49	D50	D51	D52	D53	D54	D55	D56	D57	D58	D59	D60	D61	D62	D63
AD1	AD2	AD3	AD4	AD5	X	X	X	RA0	RA1	RA2	RA3	X	X	X	X	IM	X	X	X	0	1	1	0

X: don't care

10.6.1. RA0 to RA3: ADRAM address

RA0	RA1	RA2	RA3
LSB			MSB

10.6.2. AD1 to AD5: ADATA display data

In addition to the 5 x 7, 5 x 8, or 5 x 9 dot matrix display data (MDATA), this LSI supports direct display of the five accessory display segments provided in each digit as ADATA. This display function does not use CGROM or CGRAM. The figure below shows the correspondence between the data and the display. When ADn = 1 (where n is an integer between 1 and 5) the segment corresponding to that data will be turned on.

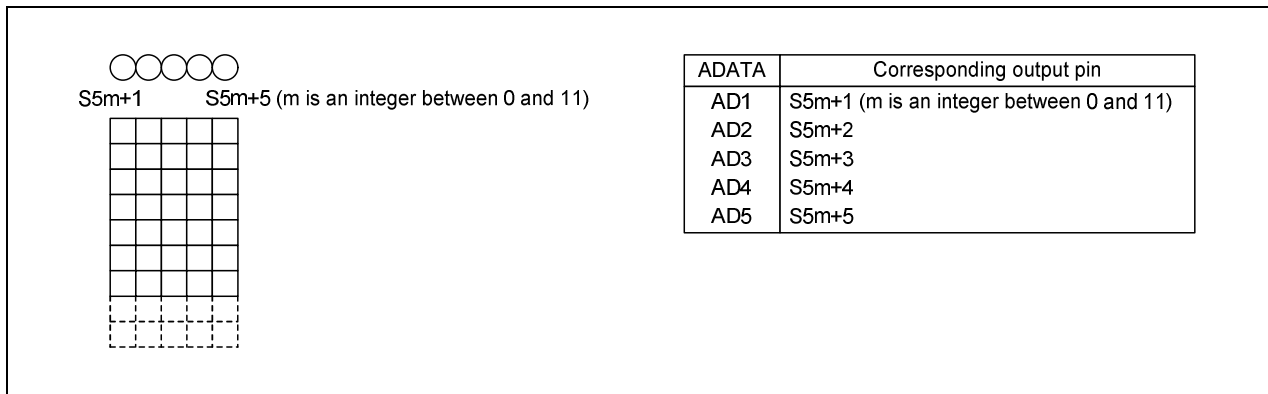

10.6.3. IM: Setting the method of writing data to ADRAM

IM	ADRAM data write method
0	Normal ADRAM data write (Specifies the ADRAM address and writes the ADRAM data.)
1	Increment mode ADRAM data write (Increments the ADRAM address by +1 each time data is written to ADRAM.)

– ADRAM data write method when IM = 0

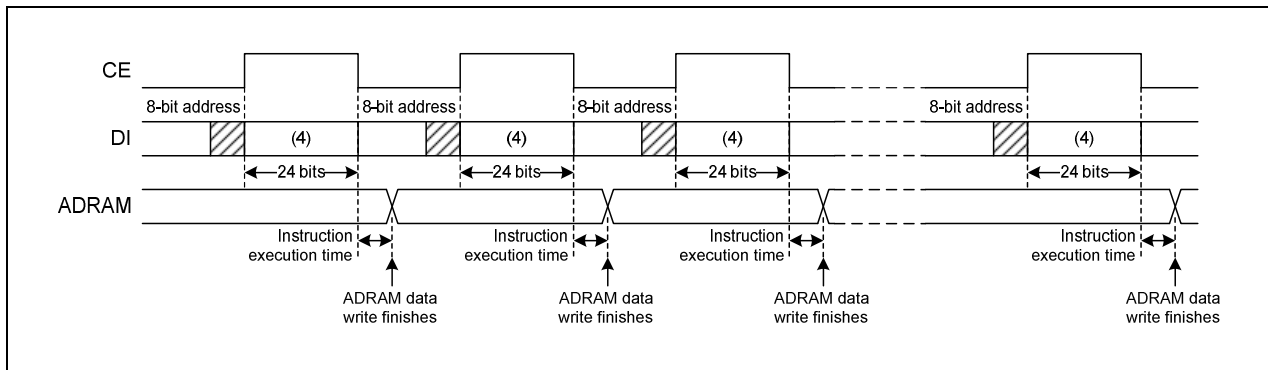

- ADRAM data write method when IM = 1 (Instructions other than the "ADRAM data write" instruction cannot be used.)

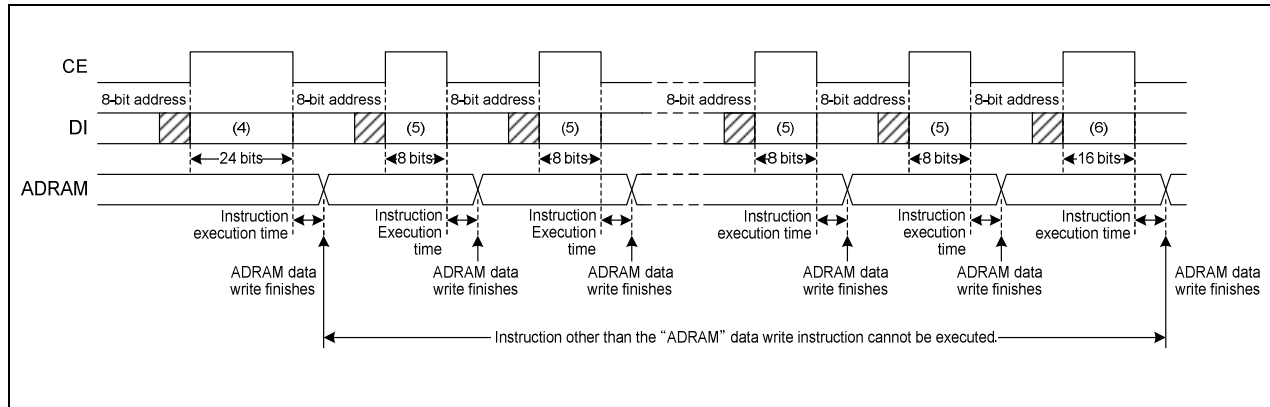

10.6.4. Data format at (4) (24 bits)

Code																							
D40	D41	D42	D43	D44	D45	D46	D47	D48	D49	D50	D51	D52	D53	D54	D55	D56	D57	D58	D59	D60	D61	D62	D63
AD1	AD2	AD3	AD4	AD5	X	X	X	RA0	RA1	RA2	RA3	X	X	X	X	IM	X	X	X	0	1	1	0

X: don't care

10.6.5. Data format at (5) (8 bits)

Code							
D56	D57	D58	D59	D60	D61	D62	D63
AD1	AD2	AD3	AD4	AD5	X	X	X

X: don't care

10.6.6. Data format at (6) (16 bits)

Code															
D48	D49	D50	D51	D52	D53	D54	D55	D56	D57	D58	D59	D60	D61	D62	D63
AD1	AD2	AD3	AD4	AD5	X	X	X	0	X	X	X	0	1	1	0

X: don't care

10.7. CGRAM DATA WRITE — Specifies the CGRAM address and stores data at that address

Code															
D0	D1	D2	D3	D4	D5	D6	D7	D8	D9	D10	D11	D12	D13	D14	D15
CD1	CD2	CD3	CD4	CD5	CD6	CD7	CD8	CD9	CD10	CD11	CD12	CD13	CD14	CD15	CD16

Code															
D16	D17	D18	D19	D20	D21	D22	D23	D24	D25	D26	D27	D28	D29	D30	D31
CD17	CD18	CD19	CD20	CD21	CD22	CD23	CD24	CD25	CD26	CD27	CD28	CD29	CD30	CD31	CD32

Code															
D32	D33	D34	D35	D36	D37	D38	D39	D40	D41	D42	D43	D44	D45	D46	D47
CD33	CD34	CD35	CD36	CD37	CD38	CD39	CD40	CD41	CD42	CD43	CD44	CD45	X	X	X

Code															
D48	D49	D50	D51	D52	D53	D54	D55	D56	D57	D58	D59	D60	D61	D62	D63
CA0	CA1	CA2	CA3	CA4	CA5	CA6	CA7	X	X	X	X	0	1	1	1

X: don't care

10.7.1. CA0 to CA7: CGRAM address

CA0	CA1	CA2	CA3	CA4	CA5	CA6	CA7
LSB				MSB			

10.7.2. CD1 to CD45: CGRAM data (5 x 7, 5 x 8, or 5 x 9 dot matrix display data)

The bit CD_n (where n is an integer between 1 and 45) corresponds to the 5 x 7, 5 x 8, or 5 x 9 dot matrix display data. The figure below shows that correspondence. The dots for which the corresponding data CD_n is 1 will be turned on.

CD1	CD2	CD3	CD4	CD5
CD6	CD7	CD8	CD9	CD10
CD11	CD12	CD13	CD14	CD15
CD16	CD17	CD18	CD19	CD20
CD21	CD22	CD23	CD24	CD25
CD26	CD27	CD28	CD29	CD30
CD31	CD32	CD33	CD34	CD35
CD36	CD37	CD38	CD39	CD40
CD41	CD42	CD43	CD44	CD45

NOTES:

1. CD1 to CD35: 5 x 7 dot matrix display data
2. CD1 to CD40: 5 x 8 dot matrix display data
3. CD1 to CD45: 5 x 9 dot matrix display data

11. NOTES ON THE POWER ON AND POWER OFF SEQUENCES

At power on: Logic block power supply (VDD) on → LCD driver block power supply (VLCD) on
 At power off: LCD driver block power supply (VLCD) off → Logic block power supply (VDD) off

However, if the logic and LCD driver block use a shared power supply, then the power supplies can be turned on and off at the same time.

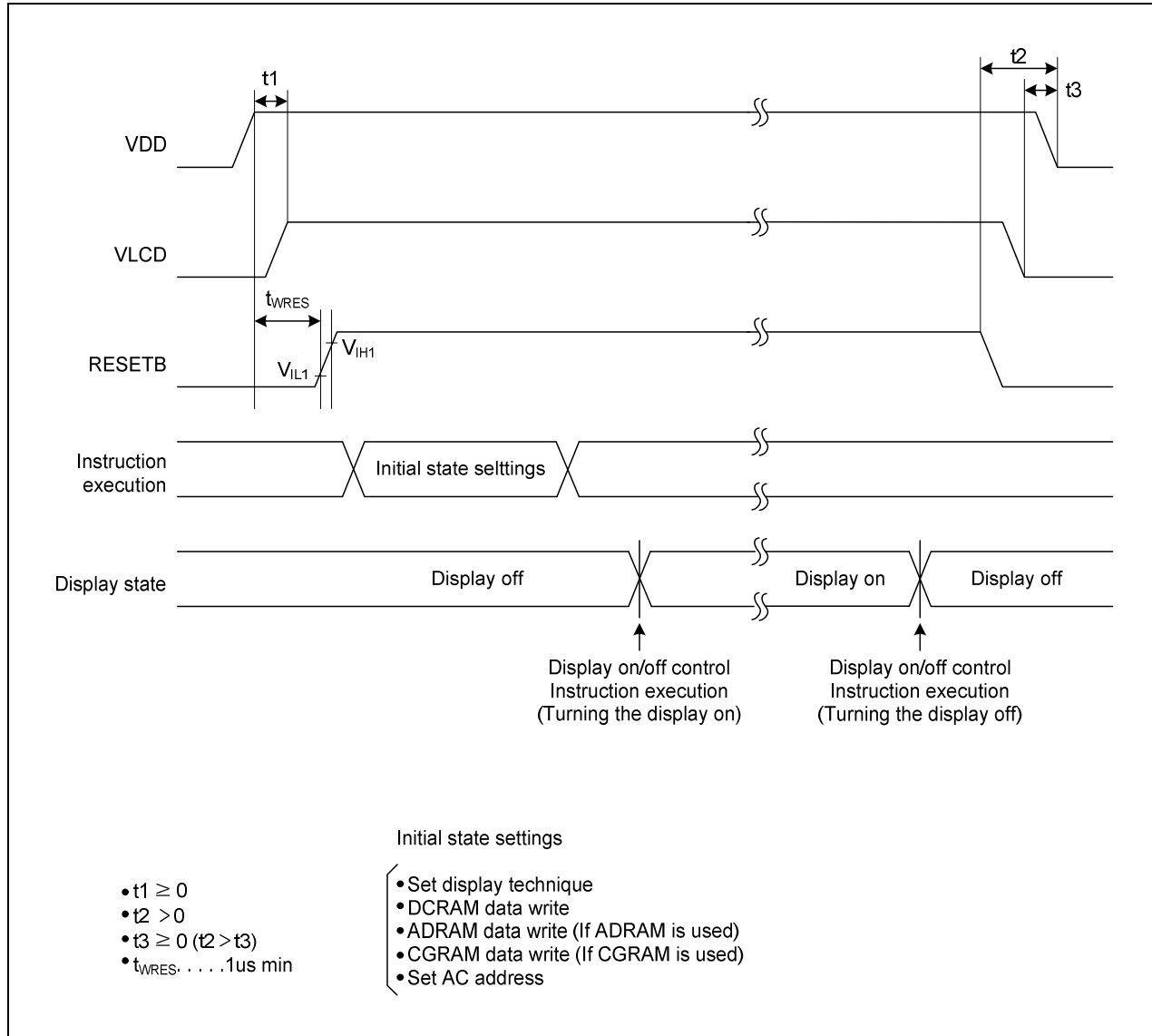

12. LCD DRIVE TECHNIQUE

12.1. 1/8 DUTY, 1/4 BIAS DRIVE TECHNIQUE

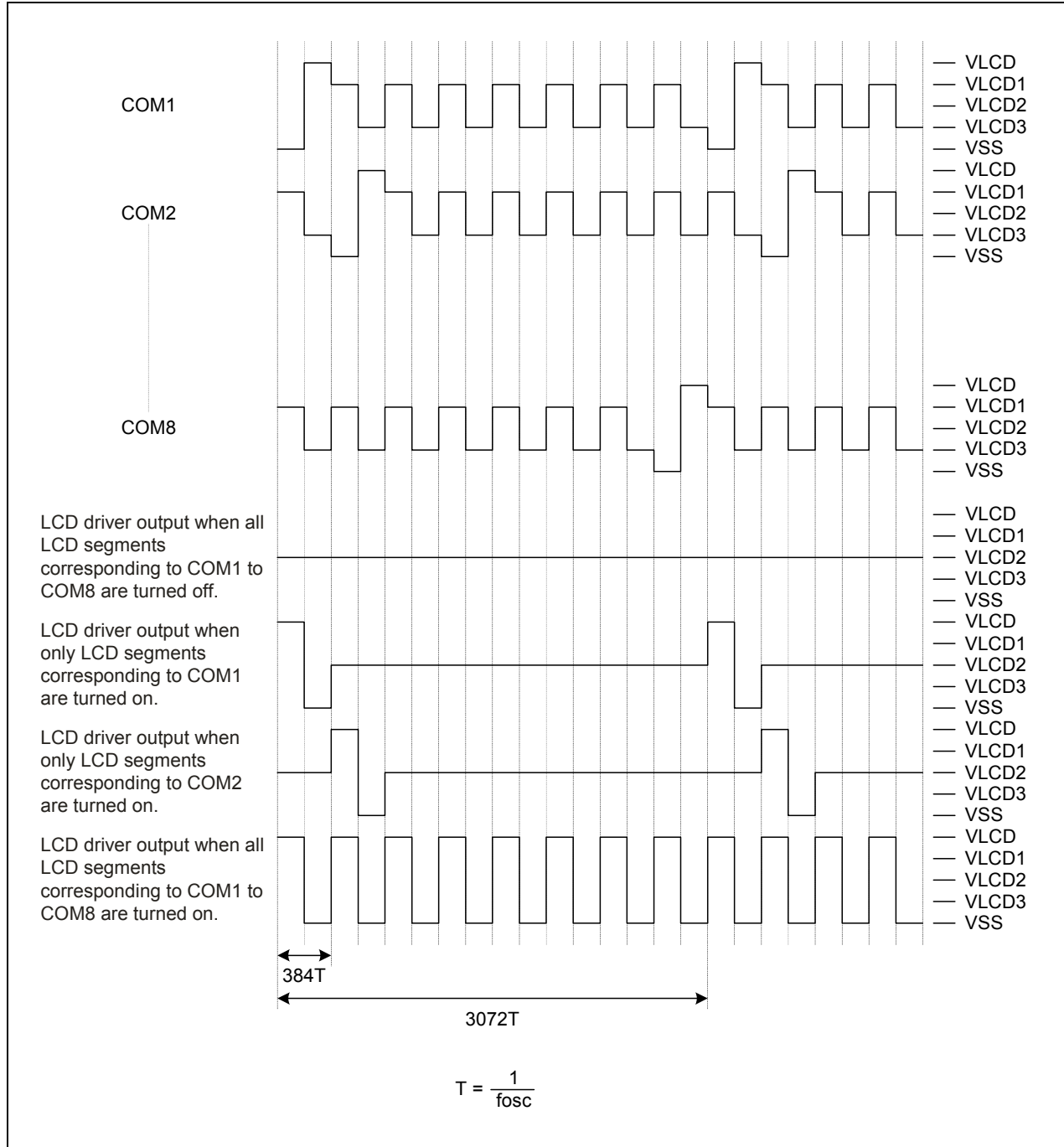

12.2. 1/9 DUTY, 1/4 BIAS DRIVE TECHNIQUE

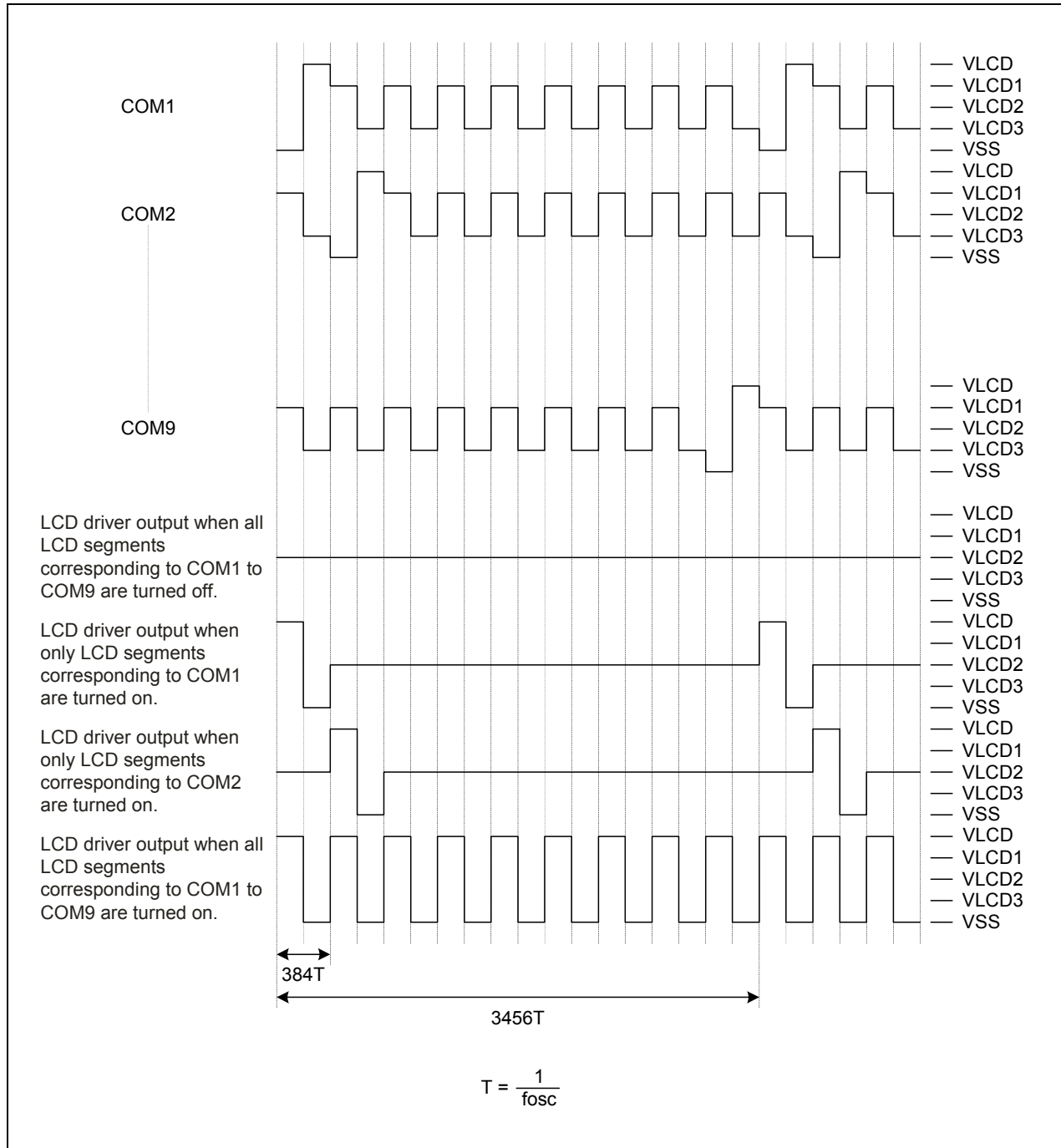

12.3. 1/10 DUTY, 1/4 BIAS DRIVE TECHNIQUE

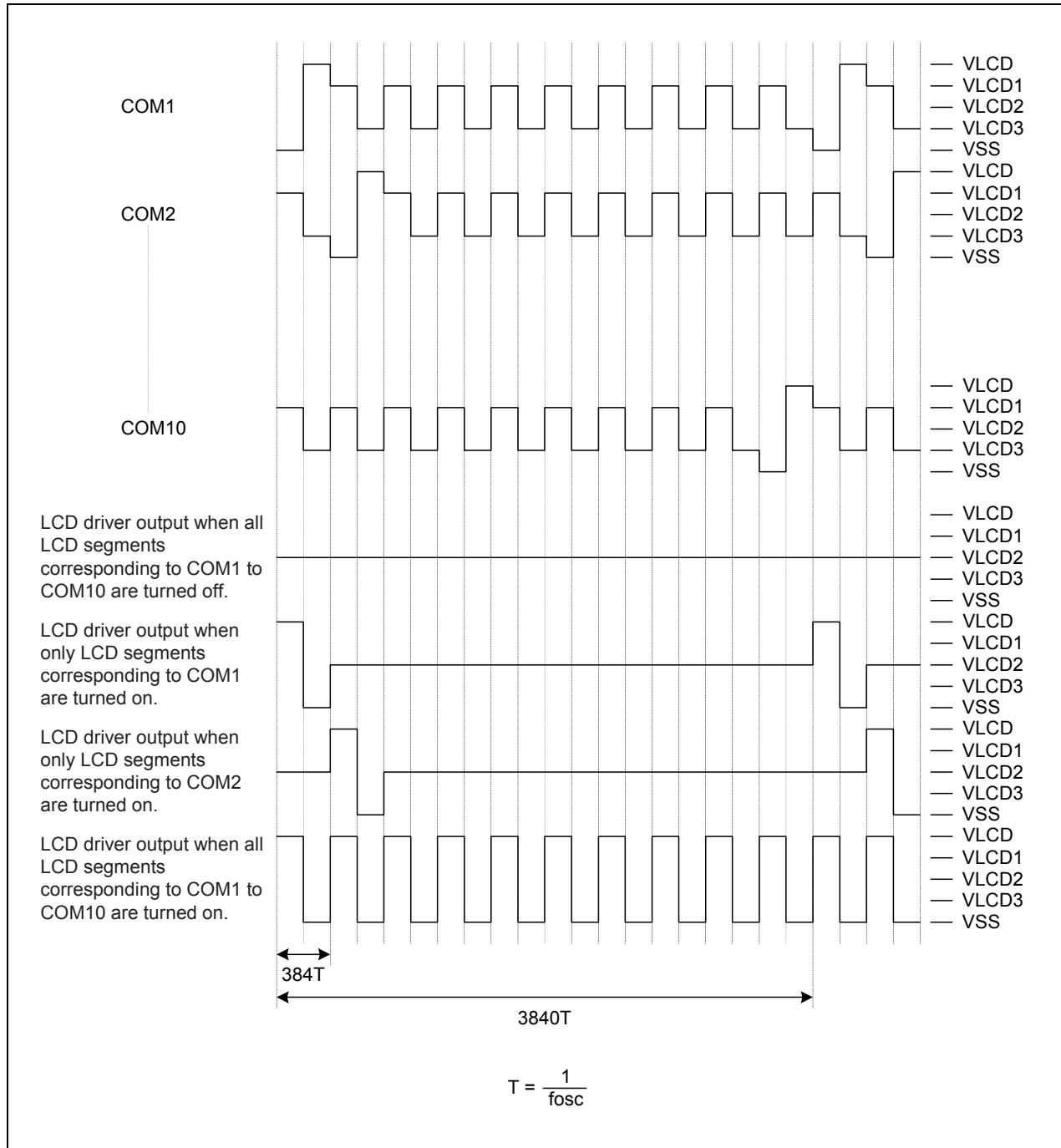

13. SAMPLE APPLICATION CIRCUIT

13.1. 1/8 DUTY, 1/4 BIAS DRIVE (FOR USE WITH NORMAL PANELS)

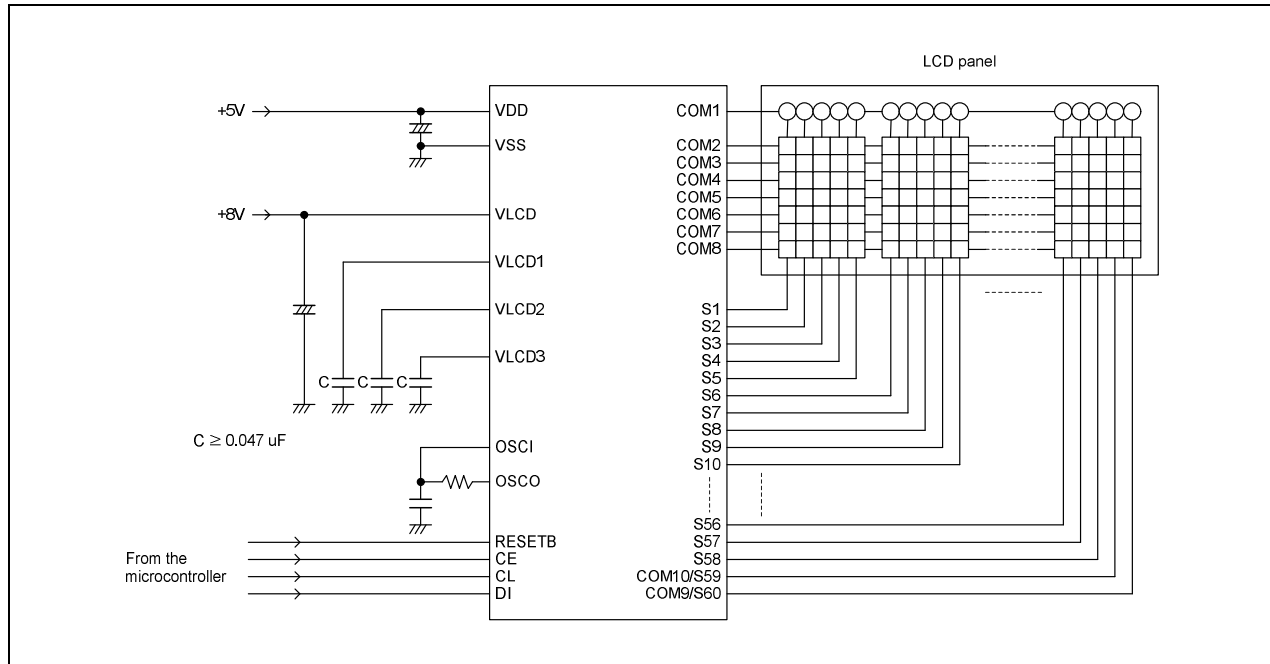

13.2. 1/8 DUTY, 1/4 BIAS DRIVE (FOR USE WITH LARGE PANELS)

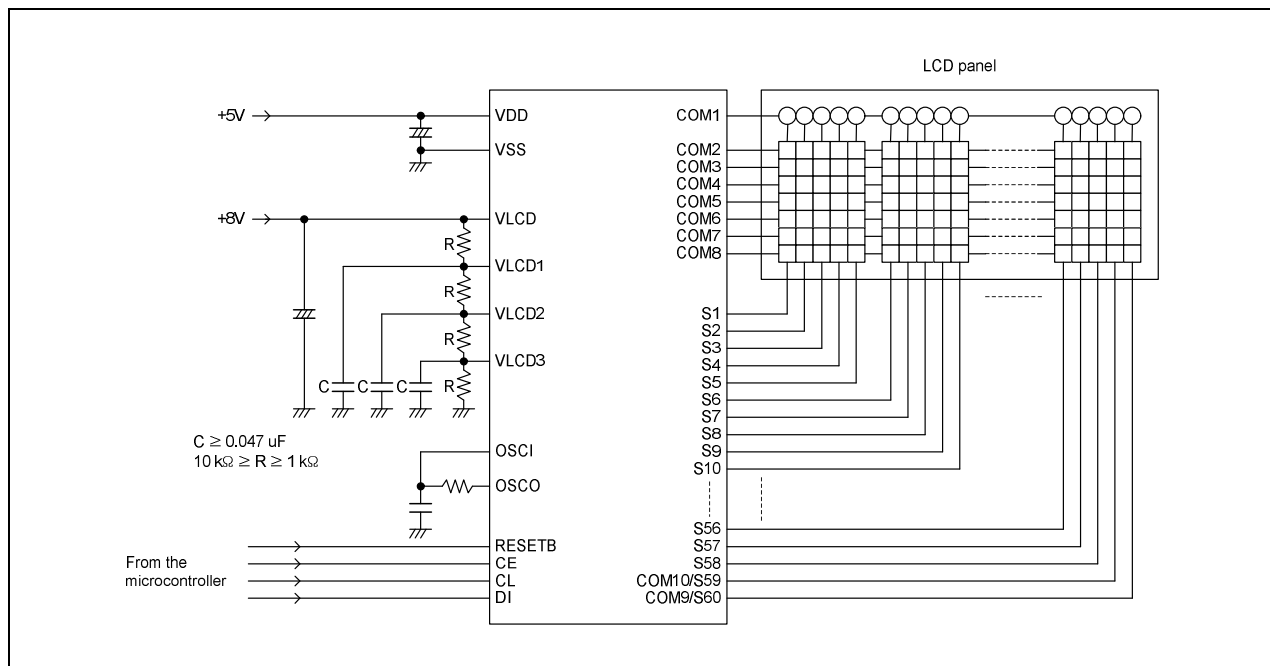

13.3. 1/9 DUTY, 1/4 BIAS DRIVE (FOR USE WITH NORMAL PANELS)

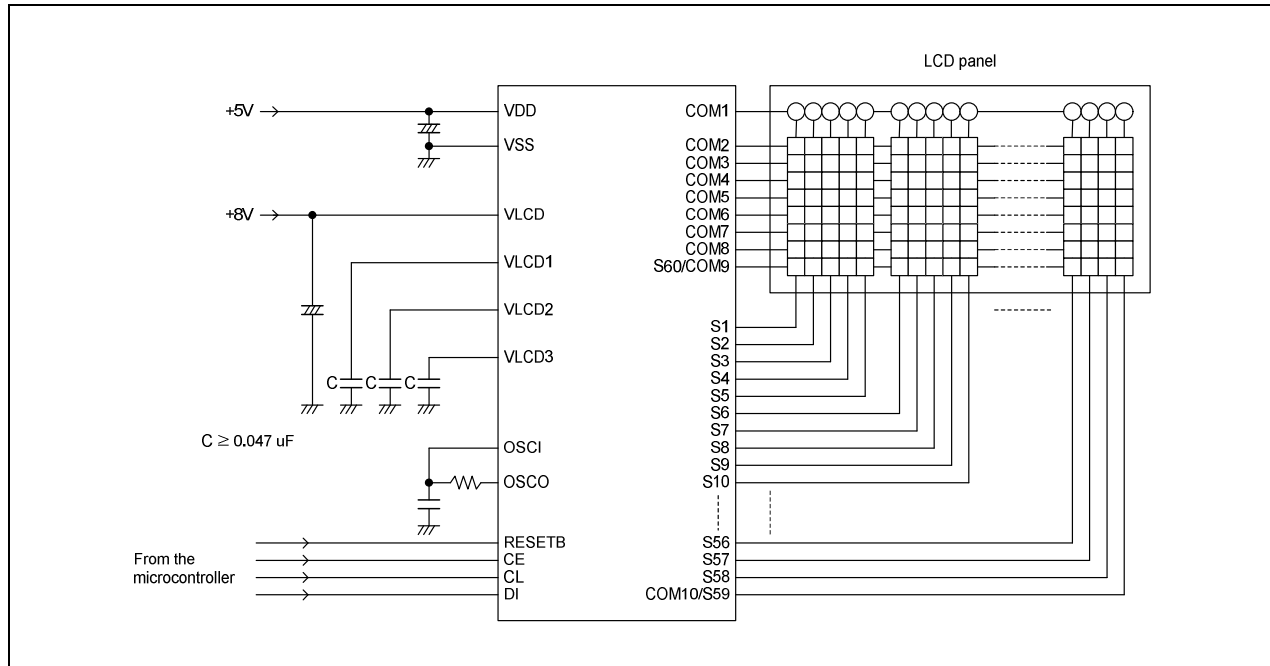

13.4. 1/9 DUTY, 1/4 BIAS DRIVE (FOR USE WITH LARGE PANELS)

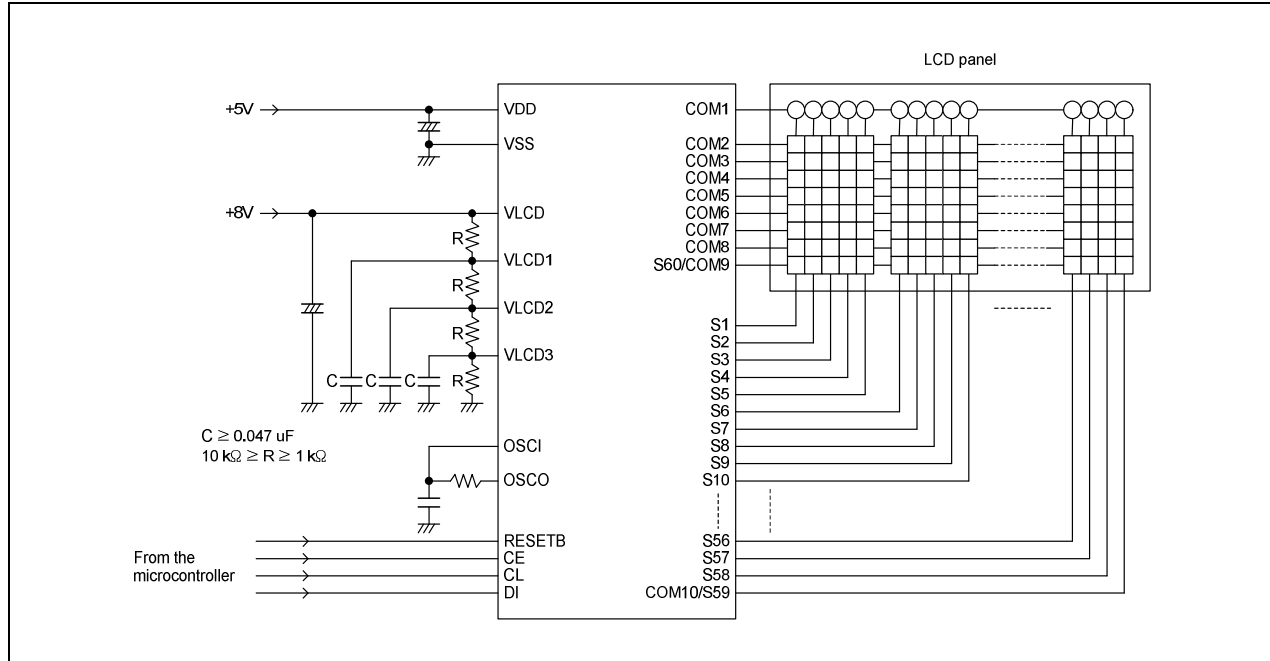

13.5. 1/10 DUTY, 1/4 BIAS DRIVE (FOR USE WITH NORMAL PANELS)

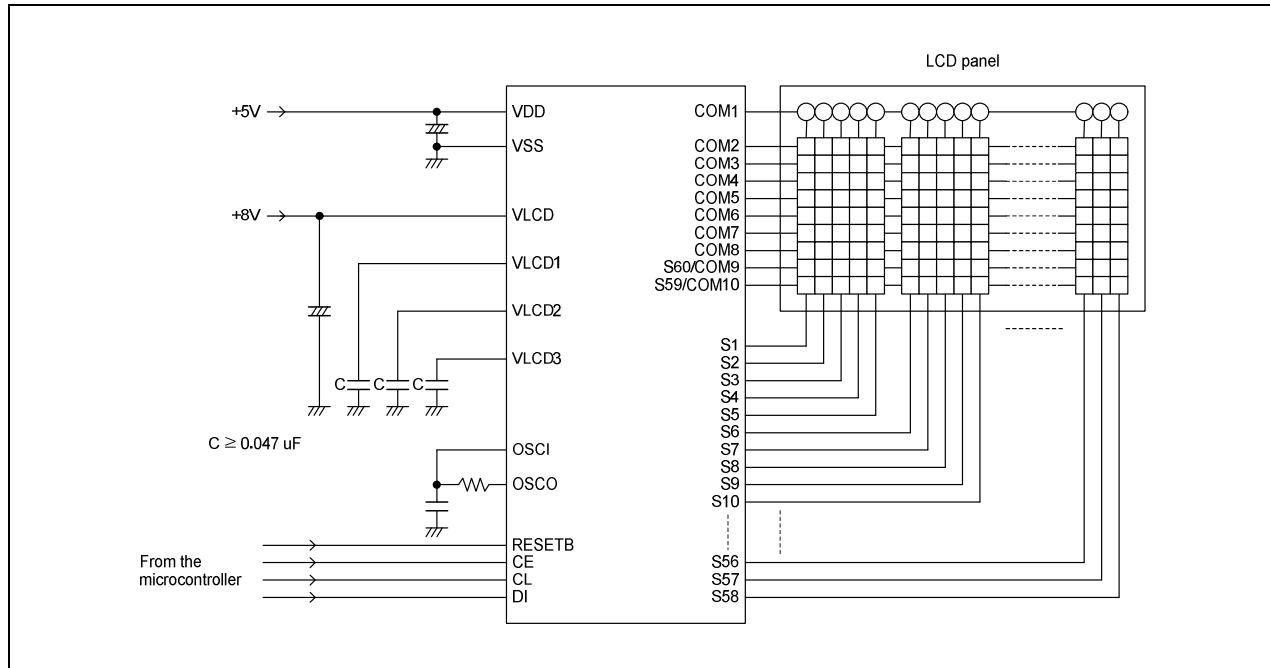

13.6. 1/10 DUTY, 1/4 BIAS DRIVE (FOR USE WITH LARGE PANELS)

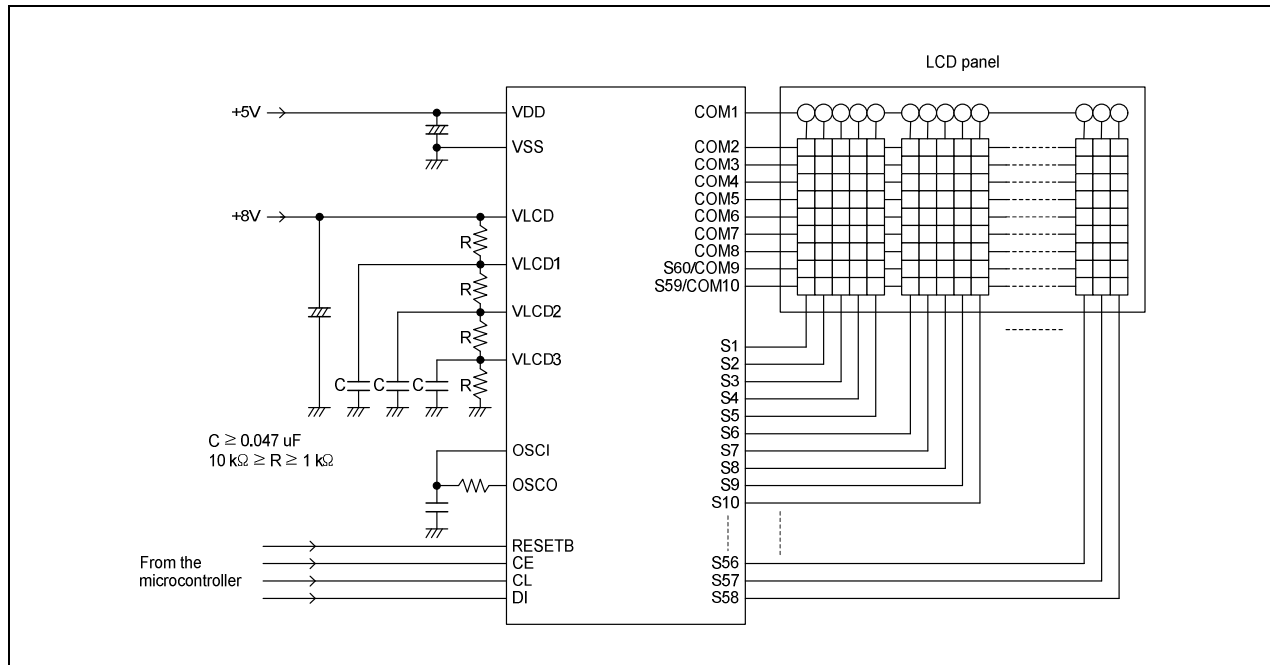

14. SAMPLE CORRESPONDENCE BETWEEN INSTRUCTIONS AND THE DISPLAY

No.	Instruction (Hex)						Display	Operation
	LSB D40 to D43	D44 to D47	D48 to D51	D52 to D55	D56 to D59	MSB D60 to D63		
1	Power application (Initialization with the RESETB pin.)						<input type="text"/>	Initializes the IC. The display is in the off state.
2	Set display technique						<input type="text"/>	Sets to 1/8 duty 1/4 bias display drive technique
3	DCRAM data write (increment mode)						<input type="text"/>	Writes the display data " " to DCRAM address 00H
	0	2	0	0	1	A		
4	DCRAM data write (increment mode)						<input type="text"/>	Writes the display data "F" to DCRAM address 01H
						6	4	
5	DCRAM data write (increment mode)						<input type="text"/>	Writes the display data "I" to DCRAM address 02H
						9	4	
6	DCRAM data write (increment mode)						<input type="text"/>	Writes the display data "N" to DCRAM address 03H
						E	4	
7	DCRAM data write (increment mode)						<input type="text"/>	Writes the display data "E" to DCRAM address 04H
						5	4	
8	DCRAM data write (increment mode)						<input type="text"/>	Writes the display data "C" to DCRAM address 05H
						3	4	
9	DCRAM data write (increment mode)						<input type="text"/>	Writes the display data "H" to DCRAM address 06H
						8	4	
10	DCRAM data write (increment mode)						<input type="text"/>	Writes the display data "I" to DCRAM address 07H
						9	4	
11	DCRAM data write (increment mode)						<input type="text"/>	Writes the display data "P" to DCRAM address 08H
						0	5	
12	DCRAM data write (increment mode)						<input type="text"/>	Writes the display data "S" to DCRAM address 09H
						3	5	
13	DCRAM data write (increment mode)						<input type="text"/>	Writes the display data " " to DCRAM address 0AH
						0	2	
14	DCRAM data write (increment mode)						<input type="text"/>	Writes the display data " " to DCRAM address 0BH
						0	2	
15	DCRAM data write (increment mode)						<input type="text"/>	Writes the display data "F" to DCRAM address 0CH
						6	4	
16	DCRAM data write (increment mode)						<input type="text"/>	Writes the display data "D" to DCRAM address 0DH
						4	4	
17	DCRAM data write (increment mode)						<input type="text"/>	Writes the display data "2" to DCRAM address 0EH
						2	3	
18	DCRAM data write (increment mode)						<input type="text"/>	Writes the display data "0" to DCRAM address 0FH
						0	3	
19	DCRAM data write (increment mode)						<input type="text"/>	Writes the display data "0" to DCRAM address 10H
						0	3	

Continued from preceding page.

No.	Instruction (Hex)						Display	Operation
	LSB D40 to D43	D44 to D47	D48 to D51	D52 to D55	D56 to D59	MSB D60 to D63		
20	DCRAM data write (increment mode)							Writes the display data "0" to DCRAM address 11H
21	DCRAM data write (increment mode)							Writes the display data " " to DCRAM address 12H
22	Set AC address							Loads the DCRAM address 00H and the ADRAM address 0H into AC
23	Display on/off control						F I N E C H I P S	Turns on the LCD for all digits (12 digits) in MDATA
24	Display shift						F I N E C H I P S F	Shifts the display (MDATA only) to the left
25	Display shift						I N E C H I P S F D	Shifts the display (MDATA only) to the left
26	Display shift						N E C H I P S F D 2	Shifts the display (MDATA only) to the left
27	Display shift						E C H I P S F D 2 0	Shifts the display (MDATA only) to the left
28	Display shift						C H I P S F D 2 0 0	Shifts the display (MDATA only) to the left
29	Display shift						H I P S F D 2 0 0 0	Shifts the display (MDATA only) to the left
30	Display shift						I P S F D 2 0 0 0	Shifts the display (MDATA only) to the left
31	Display on/off control							Set to power saving mode, turns off the LCD for all digits
32	Display on/off control						I P S F D 2 0 0 0	Turns on the LCD for all digits (12 digits) in MDATA
33	Set AC address						F I N E C H I P S	Loads the DCRAM address 00H and the ADRAM address 0H into AC

X: don't care

NOTE: This example above assumes the use of 12 digits 5 × 7 dot matrix LCD. CGRAM and ADRAM are not used.

15. FD2000 CHARACTER FONT (STANDARD)

Upper 4bits MSB 0000 Lower 4bits LSB	Character Set															
	0000 CG RAM(1)	0001 (2)	0010 (3)	0011 (4)	0100 (5)	0101 (6)	0110 (7)	0111 (8)	1000 (9)	1001 (10)	1010 (11)	1011 (12)	1100 (13)	1101 (14)	1110 (15)	1111 (16)
0000	α	β	±	÷	π	ι	Φ	φ	Æ	æ	Œ	œ	→	←	↑	↓
0001		!	”	#	\$	%	&	,	()	*	+	.	-	.	/
0010	0	1	2	3	4	5	6	7	8	9	:	:	<	=	>	?
0100	@	A	B	C	D	E	F	G	H	I	J	K	L	M	N	O
0101	P	Q	R	S	T	U	V	W	X	Y	Z	[¥]	˘	—
0110	／	a	b	c	d	e	f	g	h	i	j	k	l	m	n	o
0111	p	q	r	s	t	u	v	w	x	y	z	{		}	—	■
1000	á	à	é	è	í	ì	ó	ò	ú	ù	ñ	ç	š	ÿ	ı	İ
1001	â	ä	ê	ë	î	ï	ô	ö	û	ü	ñ	ç	š	ÿ	ı	İ
1010	／	。	「	」	、	・	ヲ	ア	イ	ウ	エ	オ	ヤ	ユ	ヨ	ツ
1011	い	ア	イ	ウ	エ	オ	カ	キ	ク	ケ	コ	サ	シ	ス	セ	ソ
1100	タ	チ	ツ	テ	ト	ナ	ニ	ヌ	ネ	ノ	ハ	ヒ	フ	ヘ	ホ	マ
1101	ミ	ム	メ	モ	ヤ	ユ	ヨ	ヲ	リ	ル	レ	ロ	ド	シ	、	。
1110	Á	À	É	È	Í	Ì	Ó	Ò	Ú	Ù	Ñ	Ç	Š	ÿ	ı	İ
1111	Á	À	É	È	Í	Ì	Ó	Ò	Ú	Ù	Ñ	Ç	Š	ÿ	ı	İ

16. ELECTRICAL CHARACTERISTICS

16.1. ABSOLUTE MAXIMUM RATINGS

($T_A = 25\text{ }^\circ\text{C}$, $V_{SS}=0\text{V}$)

Parameter	Symbol	Conditions	Ratings	Unit
Maximum supply voltage	$V_{DD\text{ max}}$	V_{DD}	-0.3 to +7.0	V
	$V_{LCD\text{ max}}$	V_{LCD}	-0.3 to +11.0	V
Input voltage	V_{IN1}	CE, CL, DI, RESETB	-0.3 to +7.0	V
	V_{IN2}	OSCI	-0.3 to $V_{DD} + 0.3$	V
	V_{IN3}	VLCD1, VLCD2, VLCD3	-0.3 to $V_{LCD} + 0.3$	V
Output voltage	V_{OUT1}	OSCO	-0.3 to $V_{DD} + 0.3$	V
	V_{OUT2}	S1 to S60, COM1 to COM10	-0.3 to $V_{LCD} + 0.3$	V
Output current	I_{OUT1}	S1 to S60	300	μA
	I_{OUT2}	COM1 to COM10	3	mA
Allowable power dissipation	$P_d\text{ max}$	$T_a = 85\text{ }^\circ\text{C}$	200	mW
Operating temperature	T_{opr}	-	-40 to +85	$^\circ\text{C}$
Storage temperature	T_{stg}	-	-55 to +125	$^\circ\text{C}$

16.2. ALLOWABLE OPERATING RANGES

($T_A = -40$ to 85°C , $V_{SS} = 0$ V)

Parameter	Symbol	Conditions	Ratings			Unit
			Min	Typ	Max	
Operating Voltage	V_{DD}	V_{DD}	2.7	-	6.0	V
	V_{LCD}	V_{LCD}	4.5	-	10.0	V
Input voltage	V_{LCD1}	V_{LCD1}	-	$3/4 V_{LCD}$	V_{LCD}	V
	V_{LCD2}	V_{LCD2}	-	$2/4 V_{LCD}$	V_{LCD}	V
	V_{LCD3}	V_{LCD3}	-	$1/4 V_{LCD}$	V_{LCD}	V
Input high level voltage	V_{IH1}	CE, CL, DI, RESETB	$0.8 V_{DD}$	-	6.0	V
	V_{IH2}	OSCI	$0.7 V_{DD}$	-	V_{DD}	V
Input low level voltage	V_{IL1}	CE, CL, DI, RESETB	0	-	$0.2 V_{DD}$	V
	V_{IL2}	OSCI	0	-	$0.3 V_{DD}$	V
Recommended external resistance	R_{OSC}	OSCI, OSCO	-	33	-	$k\Omega$
Recommended external capacitance	C_{OSC}	OSCI, OSCO	-	220	-	pF
Guaranteed oscillation range	f_{OSC}	OSC	150	300	600	kHz
Data setup time	t_{ds}	CL, DI	160	-	-	ns
Data hold time	t_{dh}	CL, DI	160	-	-	ns
CE wait time	t_{cp}	CE, CL	160	-	-	ns
CE setup time	t_{cs}	CE, CL	160	-	-	ns
CE hold time	t_{ch}	CE, CL	160	-	-	ns
High level clock pulse width	$t_{\theta H}$	CL	160	-	-	ns
Low level clock pulse width	$t_{\theta L}$	CL	160	-	-	ns
Minimum reset pulse width	t_{WRES}	RESETB	1	-	-	μs

16.3. ELECTRICAL CHARACTERISTICS IN THE ALLOWABLE OPERATING RANGES

Parameter	Symbol	Conditions	Ratings			Unit
			Min	Typ	Max	
Hysteresis	V_H	CE, CL, DI, RESETB	–	$0.1 V_{DD}$	–	V
Input high level current	I_{IH}	CE, CL, DI, RESETB, OSCI: $V_I = 6.0$ V	–	–	5.0	μ A
Input low level current	I_{IL}	CE, CL, DI, RESETB, OSCI: $V_I = 0$ V	– 5.0	–	–	μ A
Output high level voltage	V_{OH1}	S1 to S60: $IO = -20 \mu$ A	$V_{LCD} - 0.6$	–	–	V
	V_{OH2}	COM1 to COM10: $IO = -100 \mu$ A	$V_{LCD} - 0.6$	–	–	V
	V_{OH3}	OSCO: $IO = -500 \mu$ A	$V_{DD} - 1.0$	–	–	V
Output low level voltage	V_{OL1}	S1 to S60: $IO = 20 \mu$ A	–	–	0.6	V
	V_{OL2}	COM1 to COM10: $IO = 100 \mu$ A	–	–	0.6	V
	V_{OL3}	OSCO: $IO = 500 \mu$ A	–	–	1.0	V
Output middle level voltage ^{NOTE1}	V_{MID1}	S1 to S60: $IO \pm 20 \mu$ A	$2/4 V_{LCD} - 0.6$	–	$2/4 V_{LCD} + 0.6$	V
	V_{MID2}	COM1 to COM10: $IO = \pm 100 \mu$ A	$3/4 V_{LCD} - 0.6$	–	$3/4 V_{LCD} + 0.6$	V
	V_{MID3}	COM1 to COM10: $IO = \pm 100 \mu$ A	$1/4 V_{LCD} - 0.6$	–	$1/4 V_{LCD} + 0.6$	V
Oscillator frequency	f_{OSC}	OSCI, OSCO: $ROSC = 33 \text{ k}\Omega$, COSCO = 220 pF	210	300	390	kHz
Supply current	I_{DD1}	VDD: power saving mode	–	–	5	μ A
	I_{DD2}	VDD: $V_{DD} = 6.0$ V, output open, $f_{OSC} = 300$ kHz	–	450	900	μ A
	I_{LCD1}	VLCD: power saving mode	–	–	5	μ A
	I_{LCD2}	VLCD: $V_{LCD} = 10.0$ V, output open, $f_{OSC} = 300$ kHz	–	200	400	μ A

NOTE: Excluding the bias voltage generation divider resistor built into the V_{LCD1} , V_{LCD2} , and V_{LCD3} .

- Voltage Divider Resistor Circuit for Bias

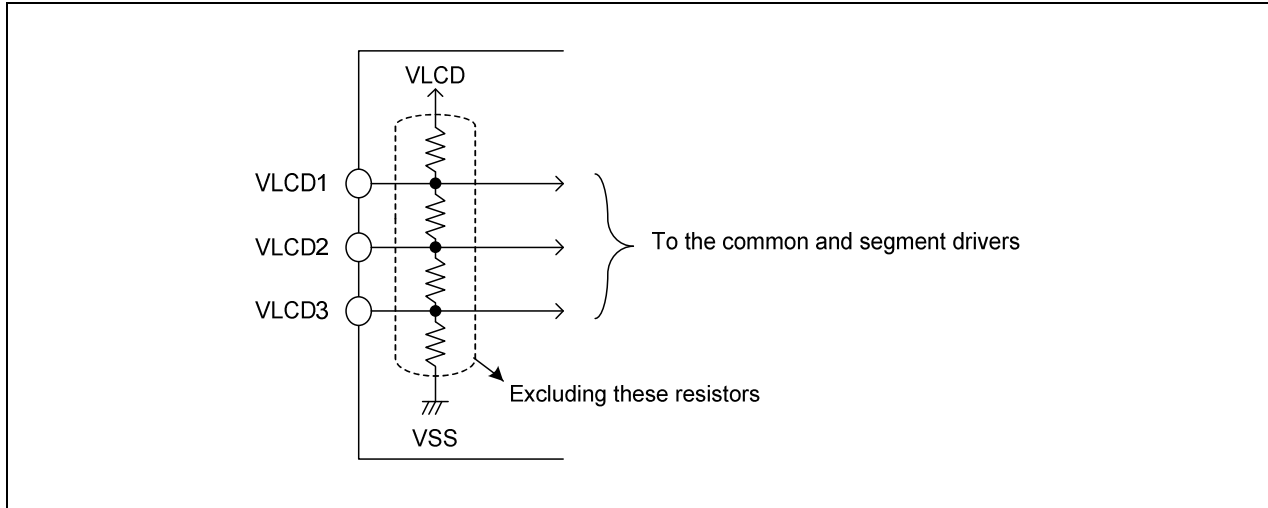

- When CL is stopped at the low level

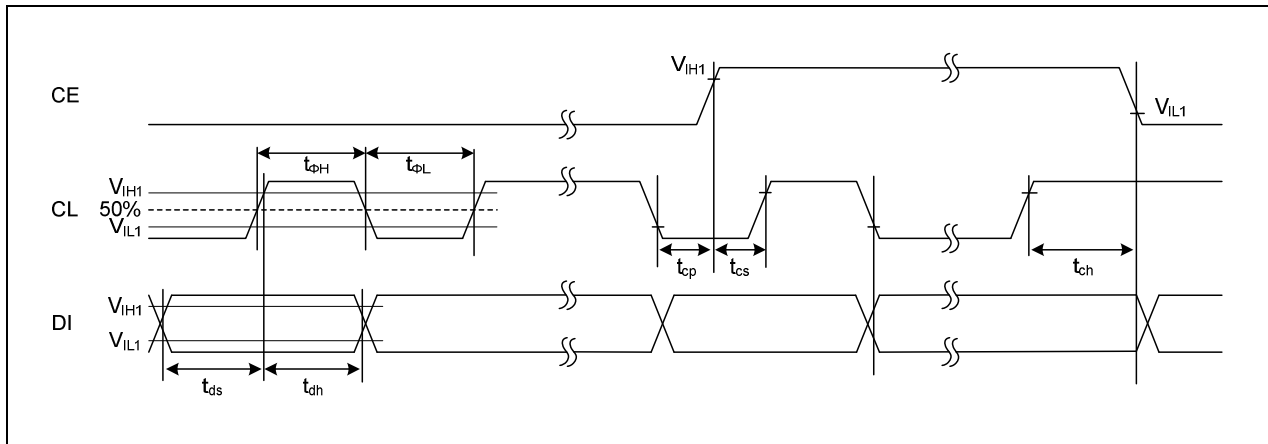

- When CL is stopped at the high level

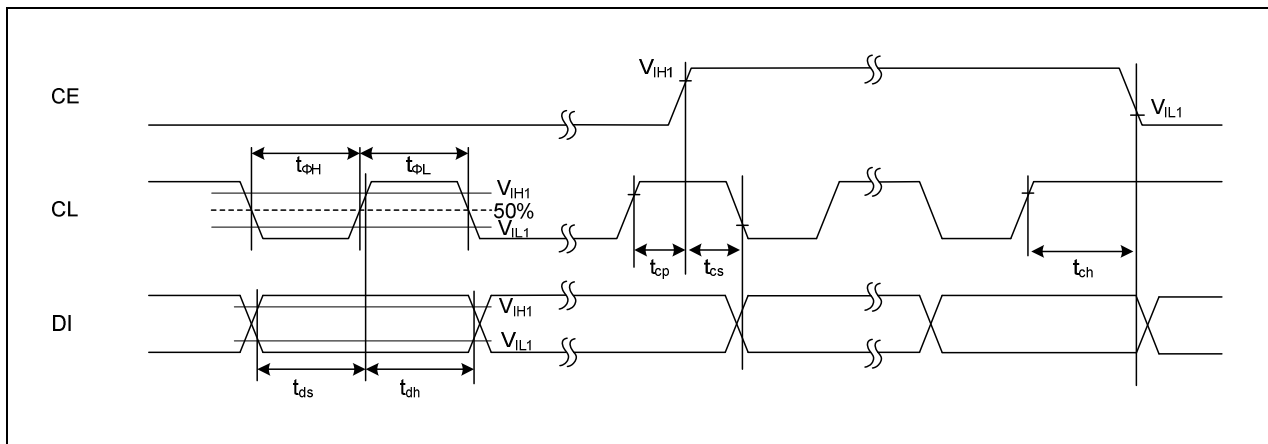

17. PACKAGE DIMENSIONS

17.1. 80-MQFP-1420

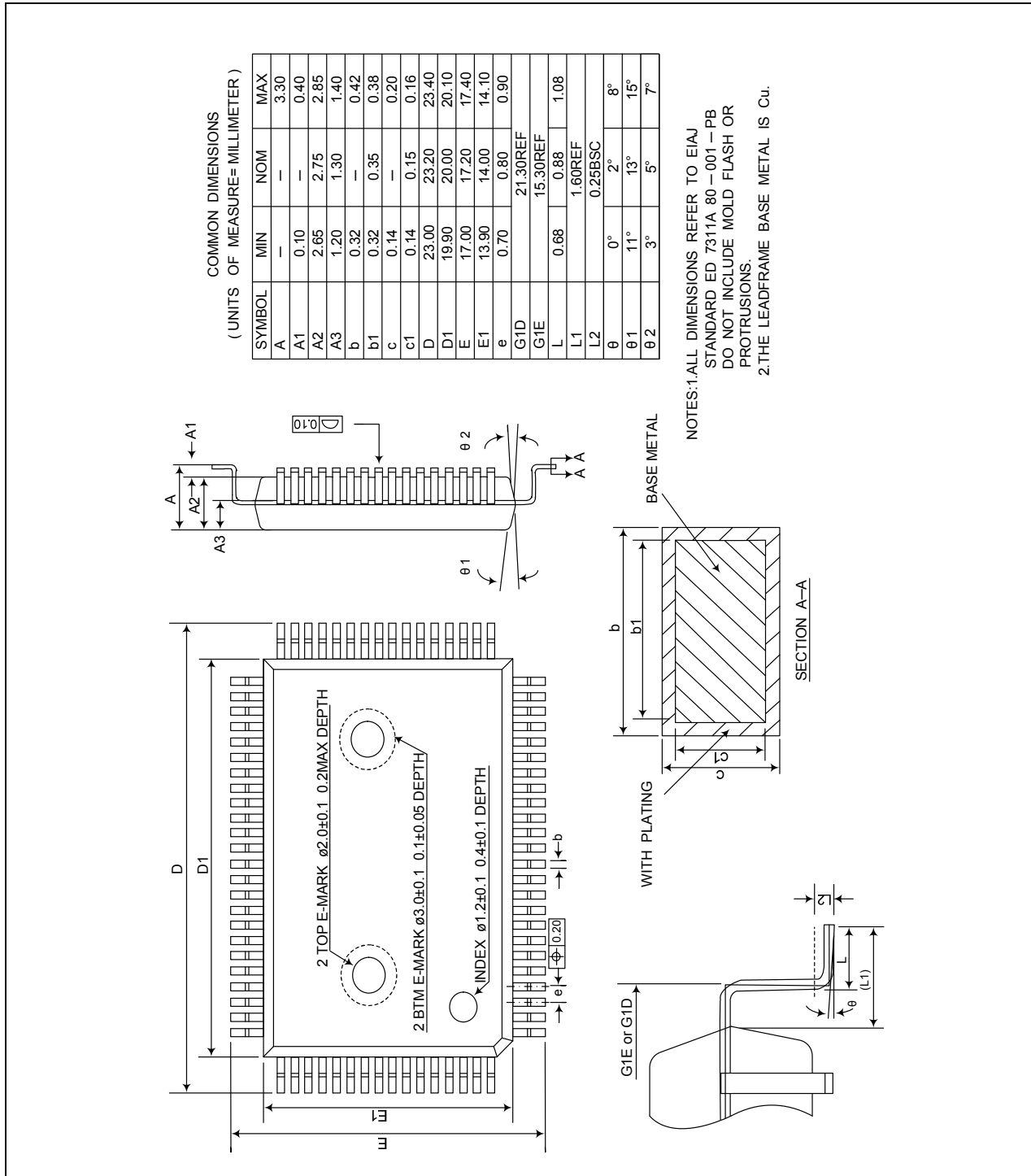

17.2. 80-LQFP-1212

COMMON DIMENSIONS
(UNITS OF MEASURE= MILLIMETER)

SYMBOL	MIN	NOM	MAX
A	—	—	1.60
A1	0.05	—	0.15
A2	1.35	1.40	1.45
A3	0.59	0.64	0.69
b	0.18	—	0.27
b1	0.17	0.20	0.23
c	0.13	—	0.18
c1	0.12	0.127	0.134
D	13.80	14.00	14.20
D1	11.90	12.00	12.10
E	13.80	14.00	14.20
E1	11.90	12.00	12.10
e	0.40	0.50	0.60
L	0.45	0.60	0.75
L1	1.00REF		
L2	0.25BSC		
R1	0.08	—	—
L2	0.08	—	0.20
θ	0°	3.5°	7°
θ1	0°	—	—
θ2	11°	12°	13°
θ3	11°	12°	13°

NOTES:
ALL DIMENSIONS REFER TO JEDEC STANDARD
MS-026 BDD DO NOT INCLUDE MOLD
FLASH OR PROTRUSIONS.

