

NEW

Encoders

Optical Encoders with Line Driver

Features:
 500 Lines per revolution
 3 Channels + complementary outputs
 Digital output
 Line driver

Series 5540

		HEDL 5540	
Lines per revolution	N	500	
Signal output, square wave		2+1 index and complementary outputs	channels
Supply voltage	V _{CC}	4,5 ... 5,5	V DC
Current consumption, typical (V _{CC} = 5 V DC)	I _{CC}	57	mA
Pulse width	P	180 ± 35	°e
Index pulse width	P _O	90 ± 35	°e
Phase shift, channel A to B	Φ	90 ± 15	°e
Logic state width	S	90 ± 35	°e
Cycle	C	360 ± 5,5	°e
Signal rise/fall time, typical	tr/tf	0,25 / 0,25	µs
Frequency range ¹⁾	f	up to 100	kHz
Inertia of code disc	J	0,6	gcm ²
Operating temperature range		0 ... + 70	°C

¹⁾ Velocity (rpm) = f (Hz) x 60/N

Ordering information

Encoder type	number of channels	lines per revolution	For combination with:
HEDL 5540 A	2+1	500	DC-Micromotors and DC-Motor-Tachos Series 2230, 2233, 2251 2338, 2342, 2356 2642, 2657, 2842 3042, 3557, 3863

The housing dimensions of the HEDL encoder are the same as the HEDS/HEDM encoders, but there is a ribbon cable instead of plain connector pins.

Suggested Line Receivers: AM26LS32, SN75175, MC3486

Features

These incremental shaft encoders in combination with the DC-Micromotors and brushless DC-Servomotors are designed for indication and control of both, shaft velocity and direction of rotation as well as for positioning.

A LED source and lens system transmits collimated light through a low inertia metal disc to give two channels with 90° phase shift.

The index pulse is synchronized with the channel \bar{B} . Each encoder channel provides complementary output signals.

The single 5 volt supply and the digital output signals are interfaced with a connector.

The line driver offers enhanced performance when the encoder is used in noisy environments, or when it is required to drive long distances.

Motor with ball bearings are recommended for continuous operation at low and high speeds and for elevated radial shaft load.

Details for the motors and suitable reduction gearheads are on separate catalog pages.

Output signals / Circuit diagram / Connector information

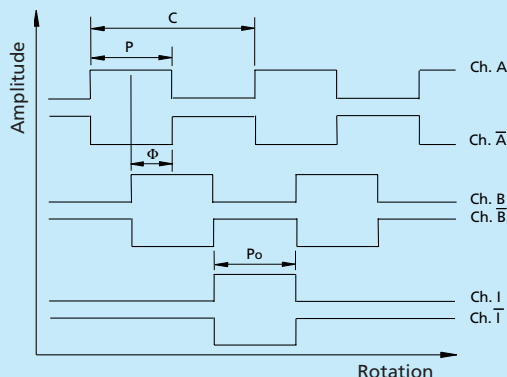

Output signals HEDL 5540
with clockwise rotation as seen from the shaft end

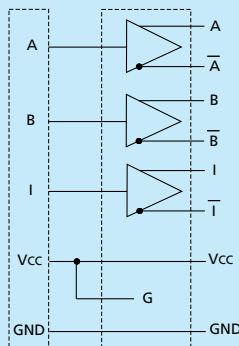

Connection diagram

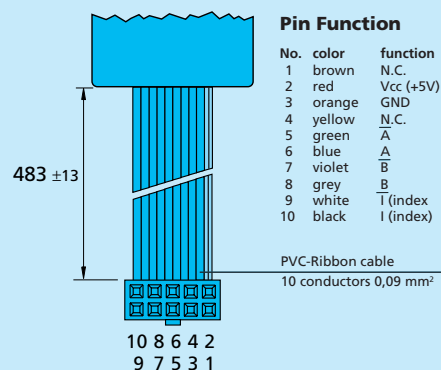

Connector
DIN-41651
grid 2,54 mm

For notes on technical data refer to "Technical Information"

Specifications subject to change without notice

