

HEDL- 64XX Series Optical Incremental Housed Encoders

Data Sheet



Features

- Two channel quadrature output with optional index pulse
- Quick and easy assembly
- Cost-effective
- Small form factor
- IP50
- Resolutions up to 512 Counts Per Revolution
- -25°C to 90° operating temperature
- Built-in RS 422 differential line driver
- Hub available in 2,3 and 4 mm shaft sizes.
- Coupling plate or threaded mount mounting options available

Description

The HEDL-64XX series are high performance, cost effective, two-channel optical incremental housed encoders with optional index pulse. These encoders emphasize high reliability, high resolution and easy assembly. The HEDL-64XX housed encoders use transmissive technology to sense rotary position. This sensor consists of an LED light source, a photodetector IC and line driver. The outputs of the HEDL-64XX encoders are 2 square waves in quadrature and an optional gated index pulse. These encoders may be quickly and easily mounted to a motor.

Available Styles

Threaded Hole Version

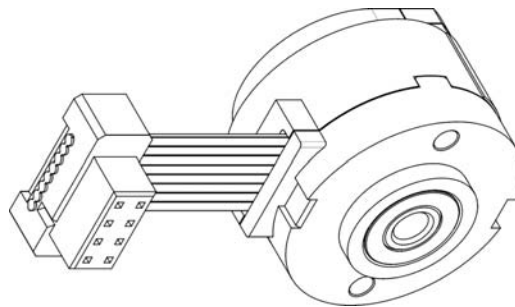

Coupling Plate Version

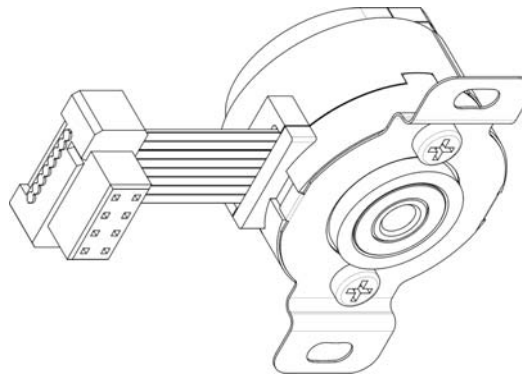

Agilent Technologies

Package Dimensions

Threaded Mount Version

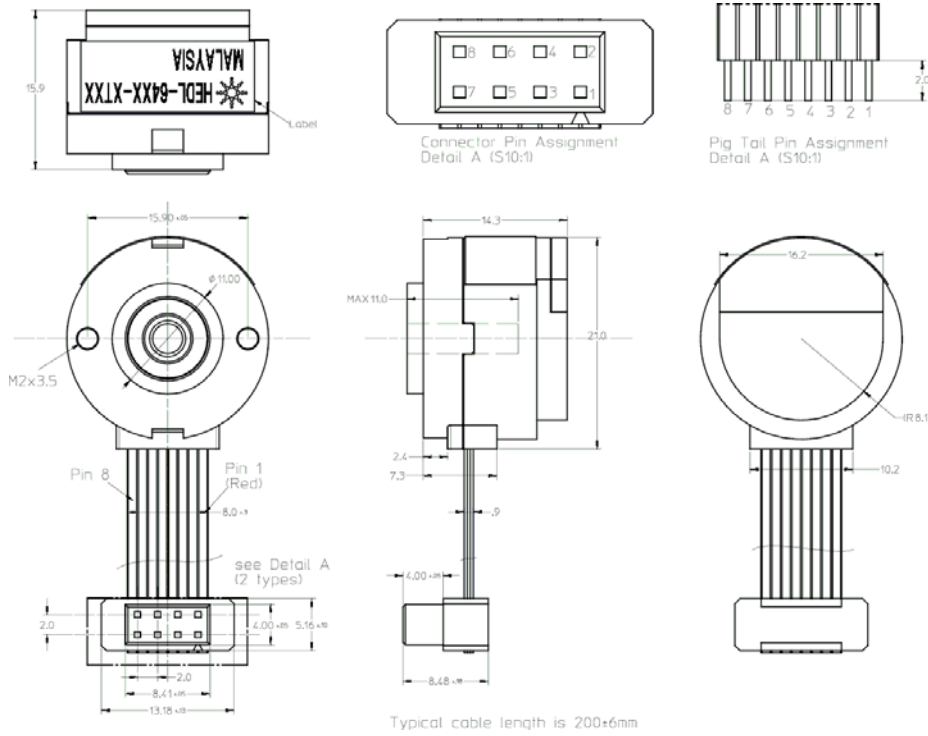

Coupling Plate Version

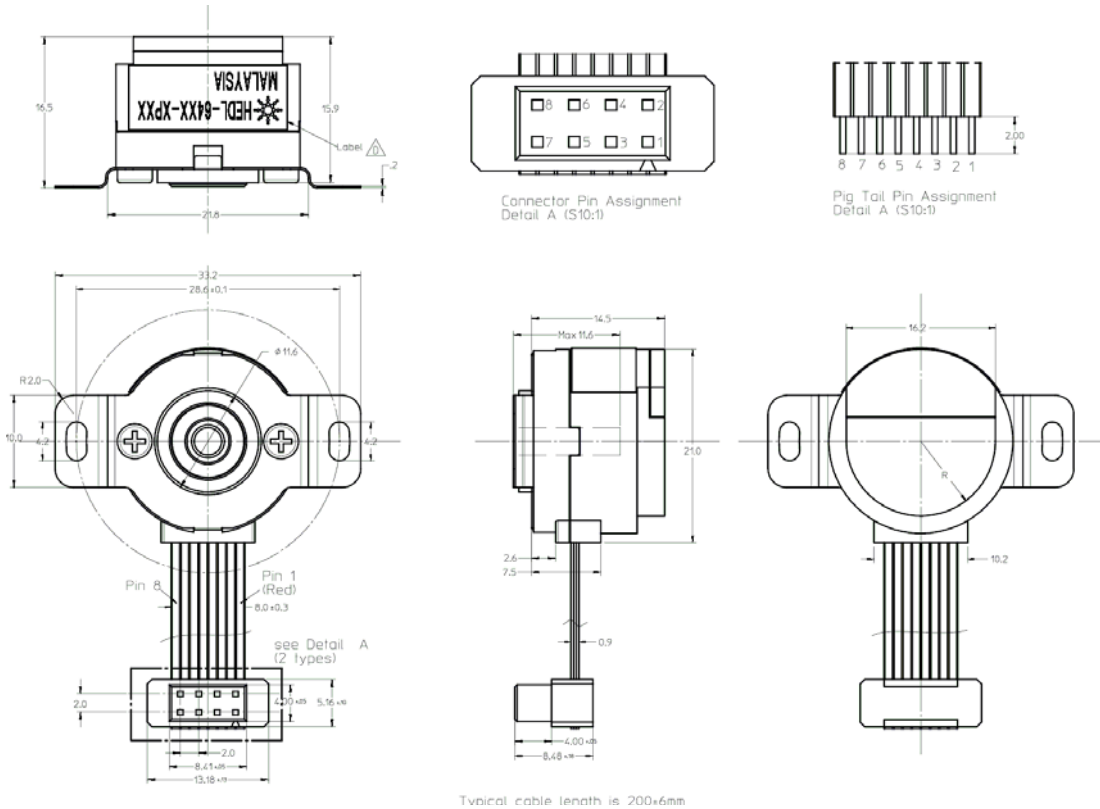

Theory of Operation

The HEDL-64XX translates rotary motion of a shaft into a two or three channel digital output. The HEDL-64XX series has four key parts: a single light emitting diode (LED) light source, a photodetector IC with a set of uniquely configured photodiodes, a line drive IC and a pair of lenses. The lens over the LED focuses light onto the codewheel. As the codewheel rotates, an alternating pattern of light and dark corresponding to the pattern of the codewheel falls upon the photodiodes.

This light is used to produce internal signals A and A', and B and B'.

As part of this "push-pull" detector system, these signals are fed through comparators and line driver that are part of the signal processing circuitry to produce the final outputs for channels A and B and index.

Definitions

Count (N): For rotary motion, the number of bar and window pairs or counts per revolution(CPR) of the codewheel. For linear motion, the number of bar and window pairs per unit length (lines per inch[LPI] or lines per mm [LPmm]).

One Cycle(C): 360 electrical degree(e), 1 bar and window pair.

One Shaft Rotation: 360 mechanical degrees, N cycles (rotary motion only).

Line Density: The number of reflective and non-reflective pairs per unit length, expressed as either lines per inch(LPI) or lines per mm (LPmm).

Cycle error(ΔC): An indication of cycle uniformity. The difference between an observed shaft angle which gives rise to one electrical cycle and the nominal angular increment of $1/N$ of a revolution

Pulse Width (P): The number of the electrical degrees that an output is high during one cycle, nominally 180° or $1/2$ a cycle.

Pulse Width Error(ΔP): The deviation in electrical degrees of the pulse width from its ideal value of 180° .

State Width (S): The number of the electrical degrees between a transition in the output of the channel B. There are 4 states per cycle, each nominally 90° .

State Width Error (ΔS): The deviation in electrical degrees of each state width from its ideal value of 90° .

Phase (ϕ): The number of electrical degrees between the center of the high state on the channel A and the center of the high state of channel B. This value is nominally 90° .

Phase error ($\Delta \phi$): The deviation in electrical degrees of the phase from its ideal value of 90° .

Position error (Δq): The normalized angular difference between the actual shaft position and the position indicated by the encoder cycle count.

Index Pulse Width (P_o): The number of electrical degrees that an index is high during one full shaft rotation. This value is nominally 90° or $1/4$ cycle.

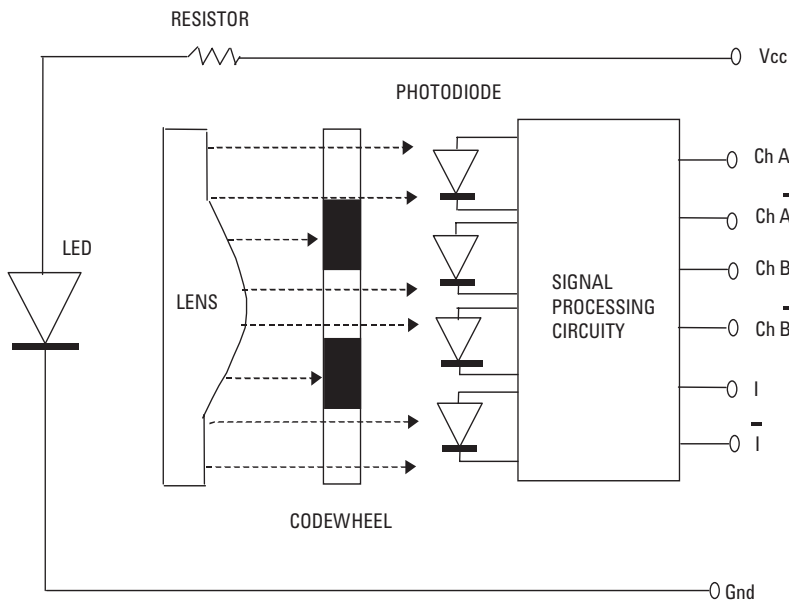

Output Waveforms

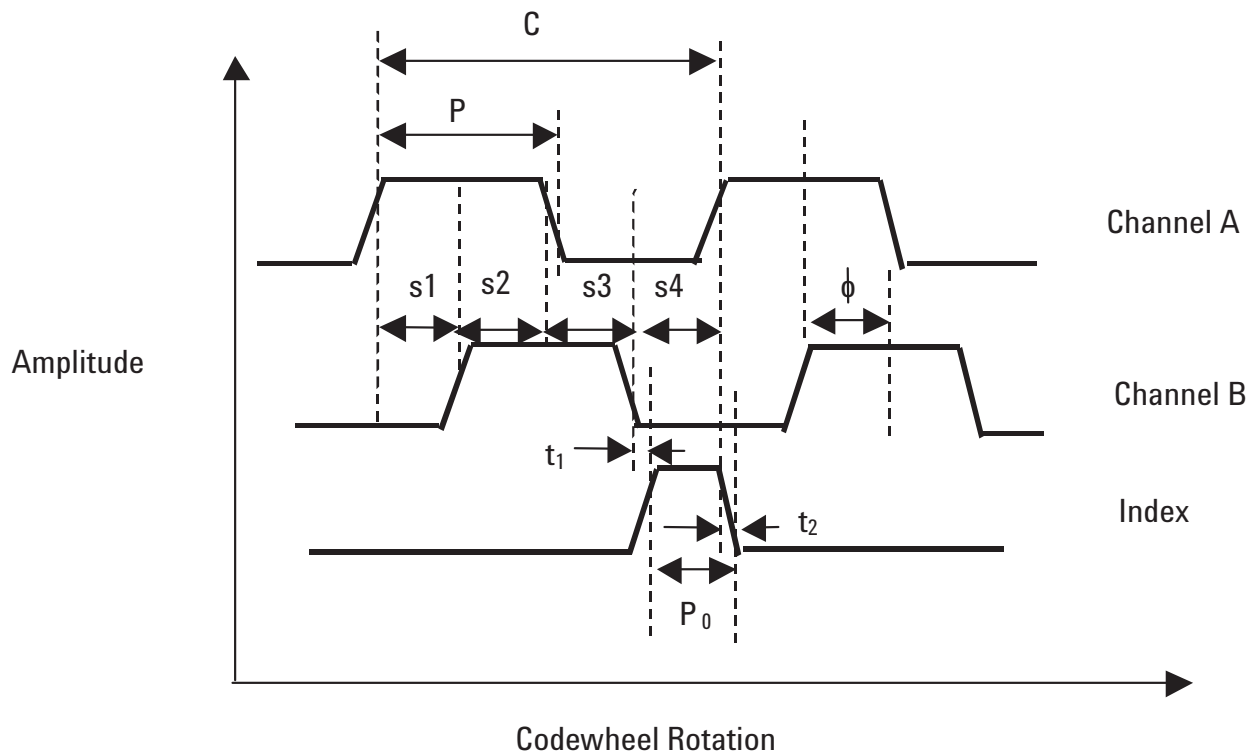

Direction of Motor Rotation

When the codewheel rotates in the clockwise direction (top view), channel A will lead channel B. If the codewheel rotates in the counterclockwise direction, channel B will lead channel A.

Pin Assignment

Pin	Signal	Description
PIN 1	Ch A	Digital output
PIN 2	Ch A'	Digital output
PIN 3	Ground	Ground
PIN 4	Ch B	Digital output
PIN 5	Ch B'	Digital output
PIN 6	Vcc	Input voltage
PIN 7	Index	Digital output
PIN 8	Index'	Digital output

Absolute Maximum Ratings

Storage Temperature	-40°C to 100°C
Operating Temperature	-25°C to 90°C
Supply Voltage	4.5 V to 5.5 V
Output Voltage	-0.5 V to 5.5V
Output Current per Channel	-2.0 mA to 25 mA
Frequency	100 kHz

Note s

$$\text{rpm} = \text{frequency} * 60 / \text{cpr}$$

Absolute Maximum Rating are those values beyond which the safety of the device cannot be guaranteed. They are not meant to imply that the device should be operated at these limits. The table "Recommended Operating Conditions and Characteristics" provides conditions for actual device operation.

Recommended Operating Conditions

Parameter	Symbol	Min.	Typical	Max.	Units	Notes
Temperature	T_A	0	25	90	°C	
Supply Voltage	V_{CC}	4.5	5.0	5.5	Volts	

Electrical Characteristics (over recommended operating conditions Typically at 25°C)

Parameter	Symbol	Min.	Typical	Max.	Units	Notes
Supply Current	I _{CC}		40	65	mA	
High level Output Voltage	V _{OH}	2.4			V	I _{OH} = -2 mA min.
Low level Output Voltage	V _{OL}			0.2	V	I _{OL} = 25 mA max

Notes

This device meets the ESD ratings below:

Class C per EIA/JESD22-A115-A (MM)

Class 1C per JESD22-A114-B (HBM)

Encoding Characteristics

Parameter	Symbol	Typical	Max.	Units
Pulse Width Error	ΔP	7	70	°e
State Width Error	ΔS	15	60	°e
Phase Error	Df	15	60	°e
Position Error	DQ	40	120	arcmin
Cycle Error	ΔC	10	45	°e
Index Pulse Width	P _o	90	120	°e
Index rise time after Ch B fall	t ₁	500	800	ns
Index fall time after Ch A rise	t ₂	150	500	ns

Mechanical Characteristics (refer to page 2 and 3 for details)

Parameter	Dimension/Details	Tolerance	Units
Recommended Motor Shaft Diameters Adhesive Mount (recommended mounting glue type is HERNON 823 anaerobic glue or equivalent)	2, 3, 4	+/- .01 (+/- .0004)	mm (in)
Allowable Motor Shaft Length Coupling plate Threaded mount	11.6 max 11.0 max		mm
Bolt Circle Diameter : Coupling plate Threaded mount	28.6 15.90	+/- 0.1 +/- 0.05	mm
Mounting Screw Size: Coupling plate Threaded mount	M2 M2x 3.5		mm
Max axial load	0.3		kgf
Max radial load	0.3		kgf
Bearing life (based on the above loading)	2 x 10 ¹⁰		rev
Unit weight	22		gm
Sealing (per IEC 529)	IP50		
Humidity	98% RH max Non condensing		
Vibration (per IEC 68-2-27)	20g @ 10 Hz ~ 500 Hz		
Shock (per IEC 68-2-27)	30 g @ 11ms		

Electrical Interface

This encoder is recommended to be used with line receiver DS26C32. Please refer to the diagram below.

Typical Applications

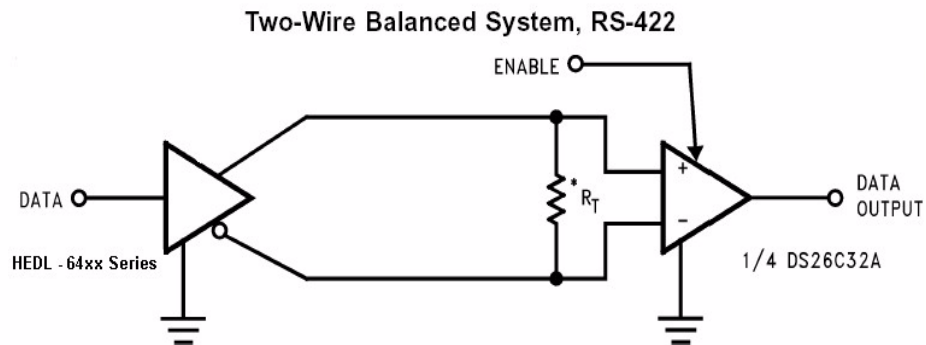

* R_T is optional although highly recommended to reduce reflection.

Connectors

The header to be used with the encoder is AMP Part Number 176264-3 or equivalent.

Mounting Considerations

The mounting plates are designed to absorb normal installation misalignment and runouts. The user should minimize misalignment as much as possible to achieve optimum performance.

APPLICATION NOTES

Mares Mounting Recommendation

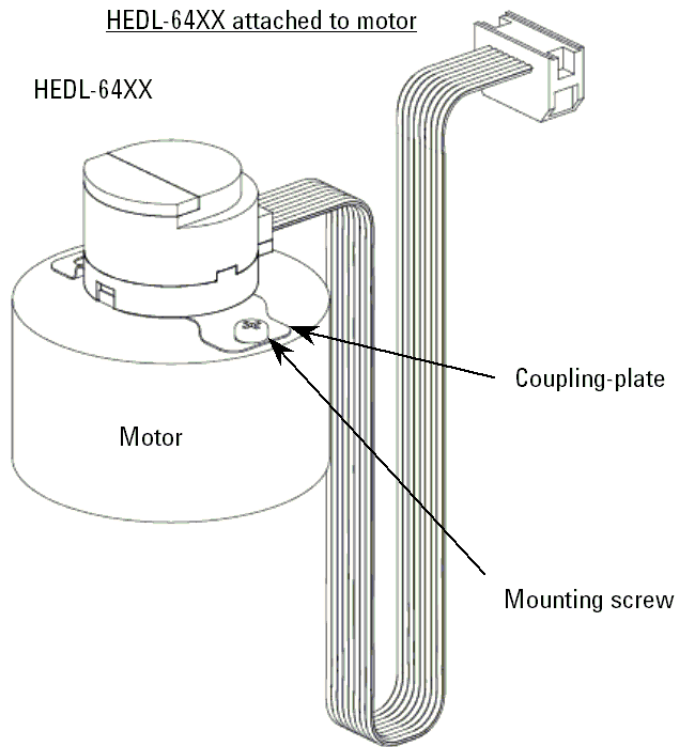

Motor

It is recommended that anaerobic glue (thread lock glue such as Herson 823 or equivalent) be applied to the mounting screws as the encoder is tightened to the motor base if the encoder will be operating under prolonged vibration or shock environment.

The use of gluing tool is highly recommended. Insert the tool into motor shaft and apply glue around the shaft as shown below. This will help to control the glue thickness. The tool will scrape the excess glue as it is being removed from motor shaft. This will prevent the glue from overflowing into motor or encoder bearing as the motor shaft is inserted into encoder.

Motor inserted with gluing tool

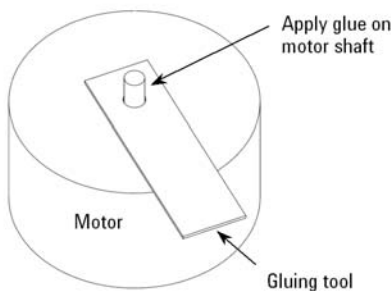

Recommended gluing tool design

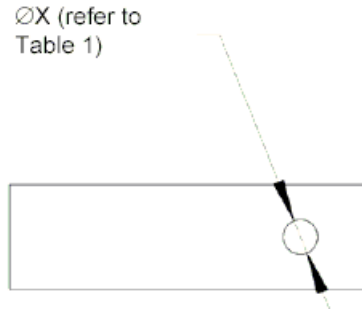

Specifications

Material	Application specific, stainless steel shim plate in general
Thickness	Application specific, ~0.3mm in general
Size	Application specific

Table 1

Motor shaft diameter, $\pm 0.01\text{mm}$	Recommended ØX , $+0.02/-0\text{mm}$
2.00	2.02
3.00	3.02
4.00	4.02

Ordering Information

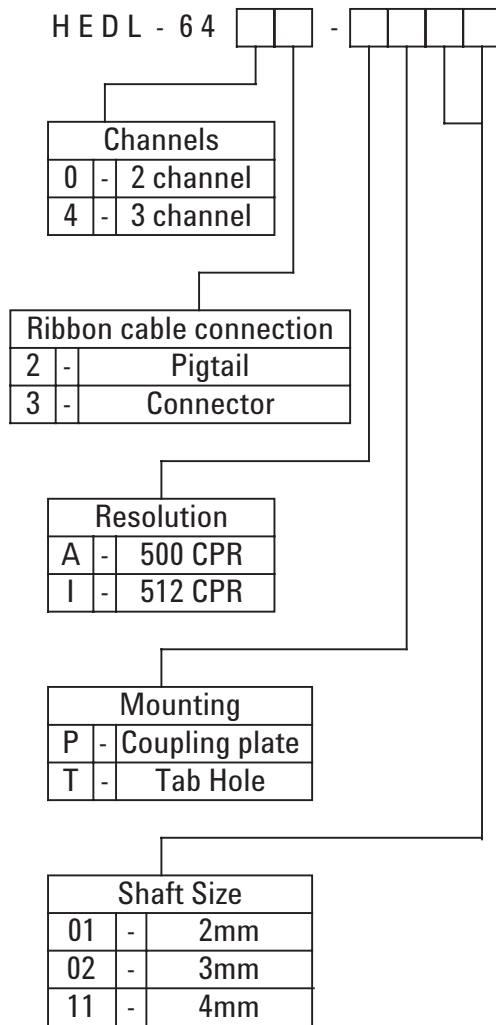

* 4mm shaft size is not available for 3 channel devices.

www.agilent.com/semiconductors

For product information and a complete list of distributors, please go to our web site.

Data subject to change.

Copyright 2003 Agilent Technologies, Inc.

October 03, 2003

5989-0101EN

