

AFP-6152

15" Stainless Fanless Touch Panel Computer With Intel® Atom™ D525 Processor, 2G RAM

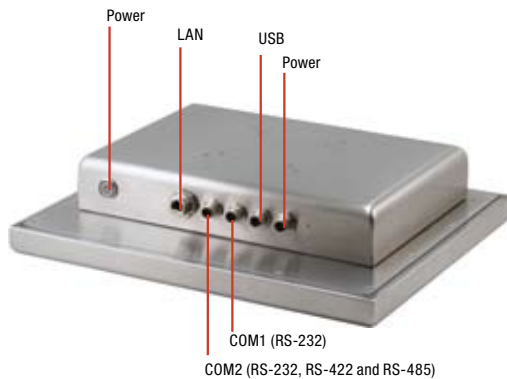
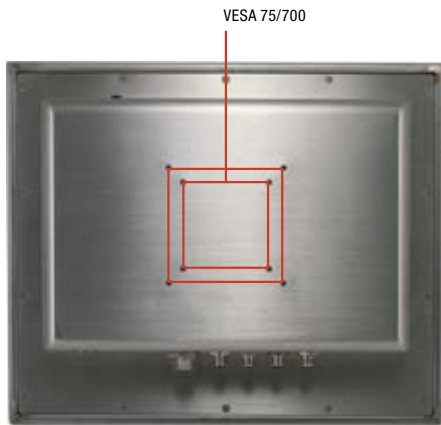

Features

- 15" XGA (1024 x 768) TFT LCD Display
- Intel® Atom™ D525 Processor, Fanless Operation
- IP66/NEMA4x-Compliant Stainless Type 316L System
- Wide Operation Temperature : -20°C ~ 50°C
- Anti-Scratch Touch Screen: 7H
- Power Input Protection:
 - Over-Voltage Protection
 - Low-Voltage Protection
 - Reverse Protection



Specifications

System	
Processor	Intel® Dual Core Atom™ D525 CPU, 1.8GHz onboard
Memory	DDR3 SODIMM x 1 up to 4GB (Wide-Temp. and Factory- Installed)
LCD/CRT Controller	Integrated in Processor
Ethernet	10/100/1000Base-TX x 1
I/O Port	M12 x 1 for USB 2.0 x 2 M12 x 1 for RS-232 x 1 M12 x 1 for RS-232/422/485 x 1 M12 x 1 for LAN x 1 Power input x 1
Storage Disk Drive	2.5" SATA Hard Disk Driver x 1/ CompactFlash™ Slot x 1 (Internal) (Wide-Temp. and Factory- Installed)
Expansion Slot	Mini-card x 1
OS Support	Window® XP, Window® 7, Linux Fedora
Mechanical	
Construction	IP66 / NEMA4x for stainless front bezel & stainless chassis
Mounting	VESA 75/100
Dimension	15.75" (W) x 12.76" (H) x 3.32" (D) (390 mm x 324mm x 84.5mm)
Carton Dimension	20.47" x 18.5" x 9.06" (520mm x 470mm x 230mm)
Gross Weight	13.2 lb (6 Kg)
Net Weight	16.1 lb (7.5Kg)
Environmental	
Operating Temperature	-4°F ~ 122°F (-20°C ~ 50°C) Ambient without Airflow -4°F ~ 130°F (-20°C ~ 55°C) Ambient with Airflow
Storage Temperature	-4°F ~ 158°F (-20°C ~ 70°C)
Storage Humidity	5%~95% @40°C, non-condensing
Vibration	1g rms/ 5~500Hz/ Random operation (HDD)
Shock	20 G peak acceleration (11 msec. Duration)
EMC	CE/FCC Class A
Power Supply	
DC input	9~30V DC input -Over-voltage protection -Low-voltage protection -Reverse protection
LCD	
Display type	15" TFT-LCD
Max Resolution	1024 x 768
Max. Colors	26.2M colors
Luminance	400
Viewing Angle	160°(H)/140°(V)
Back Light	LED
Back Light MTBF (hours)	50,000
Touchscreen	
Type	Glass-Film-Glass touch, anti-scratch 7H
Light Transmission	80%
Lifetime (Times)	10 millions times

AFP-6152

Dimension

Unit: mm

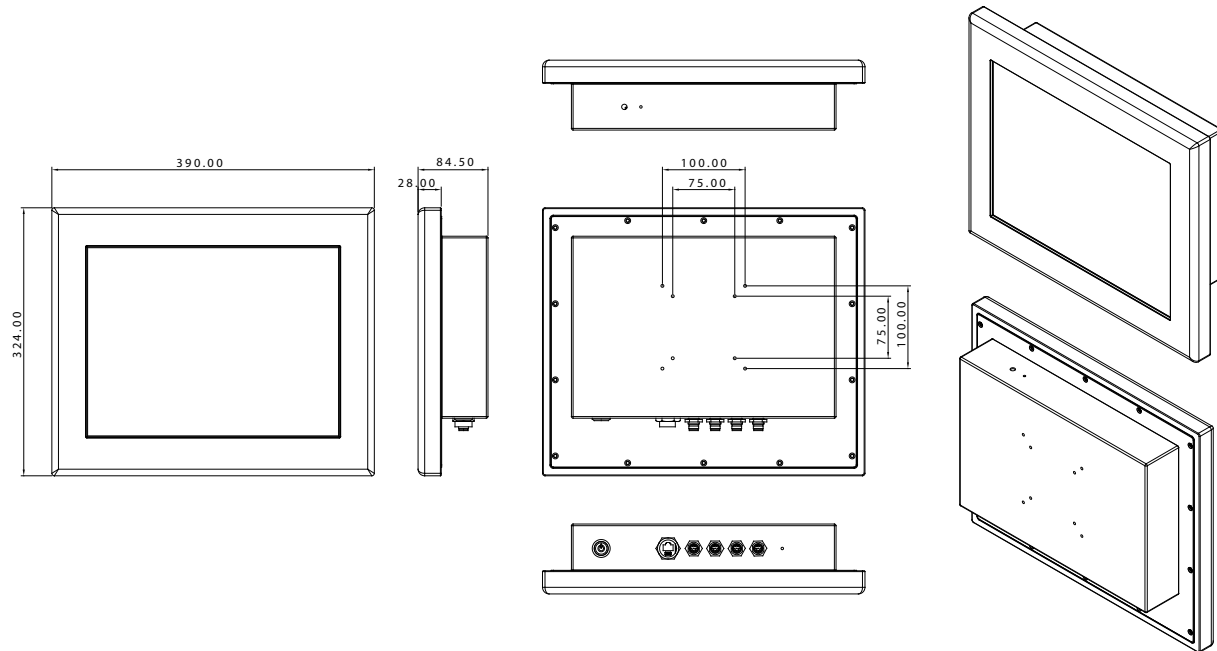

Ordering Information

- **TF-AFP-6152HTT-A1-1010**
15" Stainless Fanless Panel PC, Intel® Atom™ D525, 2G RAM, 400nits, 9~30V in, Glass-Film-Glass (GFG) Touch

Accessories In Packing

- **1700090208**
COM (D-Sub) Cable with Waterproof M12 Connector (FOX Series)
- **1709080251**
Two USB Y Cables with Waterproof M12 Connector (FOX Series)
- **M990FOX001**
3-pin Waterproof Cap Connector for DC-in or Audio Line-out Port (FOX Series)
- **P990FOX001**
Waterproof Cap Connector for LAN Port of FOX Series (RJ-45 Compliance)
- **1757910004**
AC Adapter (100W)
- **1702031802**
AC Adapter Cord (US Type)
- **1702031803**
AC Adapter Cord (European Type)
- **170203180E**
AC Adapter Cord (Japanese Type)

Optional Accessories

- **1757910004**
AC Adapter (100W)
- **1757910802**
AC Adapter Power Cord (US Type)
- **1757910803**
AC Adapter Power Cord (European Type)
- **175791080E**
AC Adapter Power Cord (Japanese Type)