

## KMM594000B

## DRAM MODULES

## 4Mx9 CMOS DRAM SIMM Memory Module

## FEATURES

- Performance range:

	$t_{RAC}$	$t_{CAC}$	$t_{RC}$
KMM594000B-6	60ns	15ns	110ns
KMM594000B-7	70ns	20ns	130ns
KMM594000B-8	80ns	20ns	150ns

- Fast Page Mode operation
- CAS-before-RAS refresh capability
- RAS-only and Hidden refresh capability
- TTL compatible inputs and outputs
- Single +5V  $\pm$  10% power supply
- 1024 cycles/16ms refresh
- JEDEC standard pinout

## GENERAL DESCRIPTION

The Samsung KMM594000B is a 4M bit x 9 Dynamic RAM high density memory module. The Samsung KMM594000B consist of nine KM41C4000BJ DRAMs in 20-pin SOJ package mounted on a 30-pin glass-epoxy substrate. A 0.22 $\mu$ F decoupling capacitor is mounted under each 4M Bit DRAM.

The KMM594000B is a Single In-line Memory Module with edge connections and is intended for mounting into 30-pin edge connector sockets.

## FUNCTIONAL BLOCK DIAGRAM

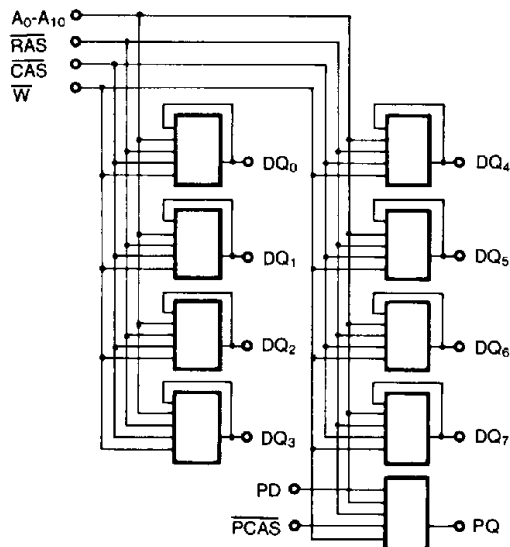

Pin Name	Pin Function
A <sub>0</sub> -A <sub>10</sub>	Address Inputs
DQ <sub>0</sub> -7	Data In/Out
$\overline{W}$	Read/Write Input
$\overline{RAS}$	Row Address Strobe
$\overline{CAS}$	Column Address Strobe
$\overline{PCAS}$	CAS for Parity
PD	Data In for Parity
PQ	Data Out for Parity
V <sub>CC</sub>	Power (+5V)
V <sub>SS</sub>	Ground
N.C.	No connection

## PIN CONFIGURATIONS

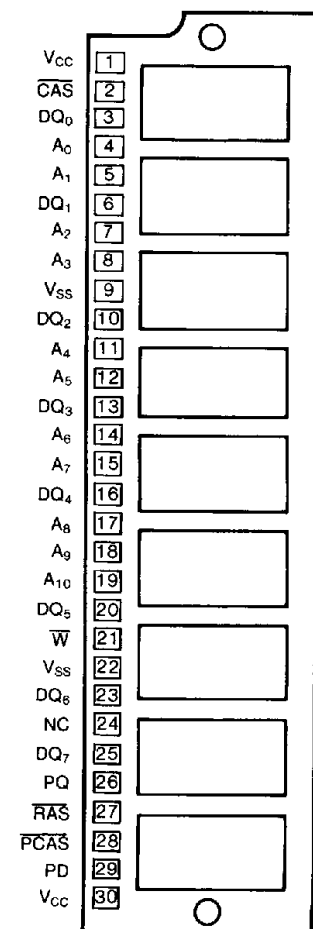

**ABSOLUTE MAXIMUM RATINGS\***

Item	Symbol	Rating	Units
Voltage on Any Pin Relative to V <sub>SS</sub>	V <sub>IN</sub> , V <sub>OUT</sub>	-1 to +7.0	V
Voltage on V <sub>CC</sub> Supply Relative to V <sub>SS</sub>	V <sub>CC</sub>	-1 to +7.0	V
Storage Temperature	T <sub>stg</sub>	-55 to +150	°C
Power Dissipation	P <sub>d</sub>	5.4	W
Short Circuit Output Current	I <sub>OS</sub>	50	mA

\* Permanent device damage may occur if "ABSOLUTE MAXIMUM RATINGS" are exceeded. Functional Operation should be restricted to the conditions as detailed in the operational sections of this data sheet. Exposure to absolute maximum rating conditions for extended periods may affect device reliability.

**RECOMMENDED OPERATING CONDITIONS** (Voltage reference to V<sub>SS</sub>, T<sub>A</sub>=0 to 70°C)

Item	Symbol	Min	Typ	Max	Unit
Supply Voltage	V <sub>CC</sub>	4.5	5.0	5.5	V
Ground	V <sub>SS</sub>	0	0	0	V
Input High Voltage	V <sub>IH</sub>	2.4	—	V <sub>CC</sub> +1	V
Input Low Voltage	V <sub>IL</sub>	-1.0	—	0.8	V

**DC AND OPERATING CHARACTERISTICS**

(Recommended operating conditions unless otherwise noted.)

Parameter	Symbol	Min	Max	Units
Operating Current* ( $\overline{RAS}$ , $\overline{CAS}$ , Address Cycling @ t <sub>RC</sub> = min.)	KMM594000B-6 KMM594000B-7 KMM594000B-8 I <sub>CC1</sub>	—	810 720 630	mA mA mA
Standby Current ( $\overline{RAS} = \overline{CAS} = V_{IH}$ )	I <sub>CC2</sub>	—	18	mA
RAS-Only Refresh Current* ( $\overline{CAS} = V_{IH}$ , $\overline{RAS}$ , Address Cycling @ t <sub>RC</sub> = min.)	KMM594000B-6 KMM594000B-7 KMM594000B-8 I <sub>CC3</sub>	—	810 720 630	mA mA mA
Fast Page Mode Current* ( $\overline{RAS} = V_{IL}$ , $\overline{CAS}$ , Address Cycling @ t <sub>PC</sub> = min.)	KMM594000B-6 KMM594000B-7 KMM594000B-8 I <sub>CC4</sub>	—	630 540 450	mA mA mA
Standby Current ( $\overline{RAS} = \overline{CAS} = V_{CC} - 0.2V$ )	I <sub>CC5</sub>	—	9	mA
$\overline{CAS}$ -Before- $\overline{RAS}$ Refresh Current* ( $\overline{RAS}$ and $\overline{CAS}$ Cycling @ t <sub>RC</sub> = min.)	KMM594000B-6 KMM594000B-7 KMM594000B-8 I <sub>CC6</sub>	—	810 720 630	mA mA mA
Input Leakage Current (Any input 0 ≤ V <sub>IN</sub> ≤ 6.5V, all other pins not under test = 0V)	I <sub>IL</sub>	-90	90	μA
Output Leakage Current (Data out is disabled, 0V ≤ V <sub>OUT</sub> ≤ 5.5V)	I <sub>OL</sub>	-10	10	μA
Output High Voltage Level (I <sub>OH</sub> = -5mA)	V <sub>OH</sub>	2.4	—	V
Output Low Voltage Level (I <sub>OL</sub> = 4.2mA)	V <sub>OL</sub>	—	0.4	V

\* NOTE: I<sub>CC1</sub>, I<sub>CC3</sub>, I<sub>CC4</sub> and I<sub>CC6</sub> are dependent on output loading and cycle rates. Specified values are obtained with the output open. I<sub>CC</sub> is specified as an average current.



## KMM594000B

## DRAM MODULES

CAPACITANCE ( $T_A=25^\circ\text{C}$ )

Item	Symbol	Min	Max	Unit
Input Capacitance ( $A_0$ - $A_{10}$ )	$C_{IN1}$	—	55	pF
Input Capacitance ( $\overline{RAS}$ , $\overline{CAS}$ , $\overline{W}$ )	$C_{IN2}$	—	65	pF
Input Capacitance ( $PD$ , $\overline{PCAS}$ )	$C_{IN3}$	—	10	pF
Input/Output Capacitance ( $DQ_0$ - $DQ_7$ )	$C_{DQ}$	—	15	pF
Output Capacitance ( $PQ$ )	$C_Q$	—	10	pF

AC CHARACTERISTICS ( $0^\circ\text{C} \leq T_A \leq 70^\circ\text{C}$ ,  $V_{CC} = 5.0\text{V} \pm 10\%$ , See notes 1, 2)

Parameter	Symbol	KMM594000B-6		KMM594000B-7		KMM594000B-8		Unit	Notes
		Min	Max	Min	Max	Min	Max		
Random read or write cycle time	$t_{RC}$	110		130		150		ns	
Access time from $\overline{RAS}$	$t_{RAC}$		60		70		80	ns	3,4
Access time from $\overline{CAS}$	$t_{CAC}$		15		20		20	ns	3,4,5
Access time from column address	$t_{AA}$		30		35		40	ns	3,11
$\overline{CAS}$ to output in Low-Z	$t_{CLZ}$	0		0		0		ns	3
Output buffer turn-off delay	$t_{OFF}$	0	15	0	20	0	20	ns	7
Transition time (rise and fall)	$t_T$	3	50	3	50	3	50	ns	2
$\overline{RAS}$ precharge time	$t_{RP}$	40		50		60		ns	
$\overline{RAS}$ pulse width	$t_{RAS}$	60	10,000	70	10,000	80	10,000	ns	
$\overline{RAS}$ hold time	$t_{RSH}$	15		20		20		ns	
$\overline{CAS}$ hold time	$t_{CSH}$	60		70		80		ns	
$\overline{CAS}$ pulse width	$t_{CAS}$	15	10,000	20	10,000	20	10,000	ns	
$\overline{RAS}$ to $\overline{CAS}$ delay time	$t_{RCD}$	20	45	20	50	20	60	ns	4
$\overline{RAS}$ to column address delay time	$t_{RAD}$	15	30	15	35	15	40	ns	11
$\overline{CAS}$ to $\overline{RAS}$ precharge time	$t_{CRP}$	5		5		5		ns	
Row address set-up time	$t_{ASR}$	0		0		0		ns	
Row address hold time	$t_{RAH}$	10		10		10		ns	
Column address set-up time	$t_{ASC}$	0		0		0		ns	
Column address hold time	$t_{CAH}$	15		15		15		ns	
Column address hold referenced to $\overline{RAS}$	$t_{AR}$	50		55		60		ns	6
Column address to $\overline{RAS}$ lead time	$t_{RAL}$	30		35		40		ns	
Read command set-up time	$t_{RCS}$	0		0		0		ns	
Read command hold referenced to $\overline{CAS}$	$t_{RCH}$	0		0		0		ns	9
Read command hold referenced to $\overline{RAS}$	$t_{RRH}$	0		0		0		ns	9
Write command hold time	$t_{WCH}$	15		15		15		ns	
Write command hold referenced to $\overline{RAS}$	$t_{WCR}$	50		55		60		ns	6
Write command pulse width	$t_{WP}$	15		15		15		ns	
Write command to $\overline{RAS}$ lead time	$t_{RWL}$	15		20		20		ns	
Write command to $\overline{CAS}$ lead time	$t_{CWL}$	15		20		20		ns	

## KMM594000B

## DRAM MODULES

## AC CHARACTERISTICS (Continued)

Parameter	Symbol	KMM594000B-6		KMM594000B-7		KMM594000B-8		Unit	Notes
		Min	Max	Min	Max	Min	Max		
Data-in set-up time	$t_{DS}$	0		0		0		ns	10
Data-in hold time	$t_{DH}$	15		15		20		ns	10
Data-in hold referenced to $\overline{RAS}$	$t_{DHR}$	50		55		60		ns	6
Refresh period	$t_{REF}$		16		16		16	ms	
Write command set-up time	$t_{WCS}$	0		0		0		ns	8
$\overline{CAS}$ set-up time (C-B-R refresh)	$t_{CSR}$	10		15		15		ns	
$\overline{CAS}$ hold time (C-B-R refresh)	$t_{CHR}$	10		15		15		ns	
$\overline{RAS}$ precharge to $\overline{CAS}$ hold time	$t_{RPC}$	5		5		5		ns	
Access time from $\overline{CAS}$ precharge	$t_{CPA}$		35		40		45	ns	3
Fast Page mode cycle time	$t_{PC}$	40		45		50		ns	
$\overline{CAS}$ precharge time (fast page)	$t_{CP}$	10		10		10		ns	
$\overline{RAS}$ pulse width (fast page)	$t_{RASP}$	60	200,000	70	200,000	80	200,000	ns	
$\overline{W}$ to $\overline{RAS}$ precharge time (C-B-R refresh)	$t_{WRP}$	10		10		10		ns	
$\overline{W}$ to $\overline{RAS}$ hold time (C-B-R refresh)	$t_{WRH}$	10		10		10		ns	
$\overline{CAS}$ precharge (C-B-R counter test)	$t_{CPT}$	20		30		30		ns	

## NOTES

1. An initial pause of 200 $\mu$ s is required after power-up followed by any 8  $\overline{RAS}$  cycles before proper device operation is achieved.
2.  $V_{IH(min)}$  and  $V_{IL(max)}$  are reference levels for measuring timing of input signals. Transition times are measured between  $V_{IH(min)}$  and  $V_{IL(max)}$ , and are assumed to be 5ns for all inputs.
3. Measured with a load equivalent to 2 TTL loads and 100pF
4. Operation within the  $t_{RCD(max)}$  limit insures that  $t_{RAC(max)}$  can be met.  $t_{RCD(max)}$  is specified as a reference point only. If  $t_{RCD}$  is greater than the specified  $t_{RCD(max)}$  limit, then access time is controlled exclusively by  $t_{CAC}$ .
5. Assumes that  $t_{RCD} \geq t_{RCD(max)}$ .
6.  $t_{AR}$ ,  $t_{WCR}$ ,  $t_{DHR}$  are referenced to  $t_{RAD(max)}$ .
7. This parameter defines the time at which the output achieves the open circuit condition and is not referenced to  $V_{OH}$  or  $V_{OL}$ .
8.  $t_{WCS}$ ,  $t_{RWD}$ ,  $t_{CWD}$  and  $t_{AWD}$  are non restrictive operating parameters. They are included in the data sheet as electrical characteristics only. If  $t_{WCS} \geq t_{WCS(min)}$  the cycle is an early write cycle and the data out pin will remain high impedance for the duration of the cycle.
9. Either  $t_{RCH}$  or  $t_{RRH}$  must be satisfied for a read cycle.
10. These parameters are referenced to the  $\overline{CAS}$  leading edge in early write cycles and to the  $\overline{W}$  leading edge in read-write cycles.
11. Operation within the  $t_{RAD(max)}$  limit insures that  $t_{RAC(max)}$  can be met.  $t_{RAD(max)}$  is specified as a reference point only. If  $t_{RAD}$  is greater than the specified  $t_{RAD(max)}$  limit, then access time is controlled by  $t_{AA}$ .

Please refer to attached Timing Chart |



ELECTRONICS

# KMM594000B

# DRAM MODULES

## PACKAGE DIMENSIONS

Units: Inches (millimeters)

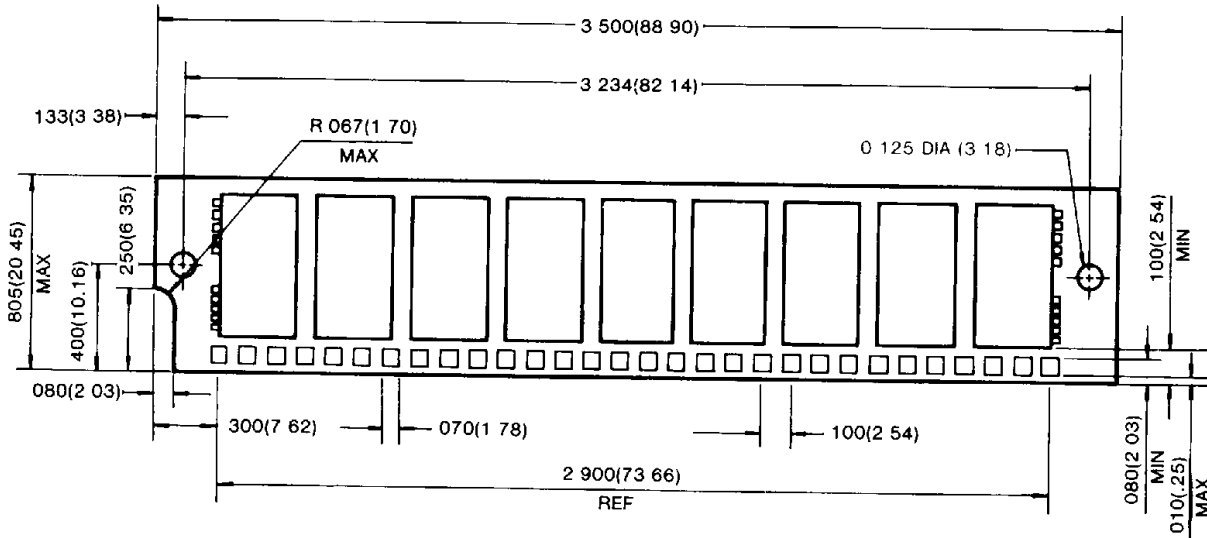

Tolerances. ± 005(.13) unless otherwise specified

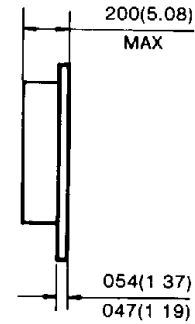

2