

2Mx32 DRAM SIMM

(1MX16 Base)

www.DataSheet.in

Revision 0.0

November 1997

Revision History

Version 0.0 (November 1997)

- Changed module PCB from 6-Layer to 4-Layer.
- Changed Module Part No. from KMM5322204CW/CWG to KMM5322204C2W/C2WG caused by PCB revision .

www.DataSheet.in

KMM5322204C2W/C2WG Fast Page Mode with Extended Data Out
 2M x 32 DRAM SIMM using 1Mx16 , 1K Refresh, 5V

GENERAL DESCRIPTION

The Samsung KMM5322204C2W is a 2Mx32bits Dynamic RAM high density memory module. The Samsung KMM5322204C2W consists of four CMOS 1Mx16bits DRAMs in 42-pin SOJ package mounted on a 72-pin glass-epoxy substrate. A 0.1 or 0.22uF decoupling capacitor is mounted on the printed circuit board for each DRAM. The KMM5322204C2W is a Single In-line Memory Module with edge connections and is intended for mounting into 72 pin edge connector sockets.

PERFORMANCE RANGE

Speed	t _{RAC}	t _{CAC}	t _{RC}	t _{HPC}
-5	50ns	15ns	90ns	25ns
-6	60ns	15ns	110ns	30ns

FEATURES

- Part Identification
 - KMM5322204C2W(1024 cycles/16ms Ref, SOJ, Solder)
 - KMM5322204C2WG(1024 cycles/16ms Ref, SOJ, Gold)
- Fast Page Mode with Extended Data Out
- $\overline{\text{CAS}}$ -before- $\overline{\text{RAS}}$ refresh capability
- $\overline{\text{RAS}}$ -only and Hidden refresh capability
- TTL compatible inputs and outputs
- Single +5V±10% power supply
- JEDEC standard PDPin & pinout
- PCB : Height(750mil), double sided component

PIN CONFIGURATIONS

Pin	Symbol	Pin	Symbol
1	V _{SS}	37	NC
2	DQ0	38	NC
3	DQ16	39	V _{SS}
4	DQ1	40	$\overline{\text{CAS0}}$
5	DQ17	41	$\overline{\text{CAS2}}$
6	DQ2	42	$\overline{\text{CAS3}}$
7	DQ18	43	$\overline{\text{CAS1}}$
8	DQ3	44	$\overline{\text{RAS0}}$
9	DQ19	45	$\overline{\text{RAS1}}$
10	V _{CC}	46	NC
11	NC	47	$\overline{\text{W}}$
12	A0	48	NC
13	A1	49	DQ8
14	A2	50	DQ24
15	A3	51	DQ9
16	A4	52	DQ25
17	A5	53	DQ10
18	A6	54	DQ26
19	NC	55	DQ11
20	DQ4	56	DQ27
21	DQ20	57	DQ12
22	DQ5	58	DQ28
23	DQ21	59	V _{CC}
24	DQ6	60	DQ29
25	DQ22	61	DQ13
26	DQ7	62	DQ30
27	DQ23	63	DQ14
28	A7	64	DQ31
29	NC	65	DQ15
30	V _{CC}	66	NC
31	A8	67	PD1
32	A9	68	PD2
33	$\overline{\text{RAS1}}$	69	PD3
34	$\overline{\text{RAS0}}$	70	PD4
35	NC	71	NC
36	NC	72	V _{SS}

PIN NAMES

Pin Name	Function
A0 - A9	Address Inputs
DQ0 - DQ31	Data In/Out
$\overline{\text{W}}$	Read/Write Enable
$\overline{\text{RAS0}}$, $\overline{\text{RAS1}}$	Row Address Strobe
$\overline{\text{CAS0}}$ - $\overline{\text{CAS3}}$	Column Address Strobe
PD1 -PD4	Presence Detect
V _{CC}	Power(+5V)
V _{SS}	Ground
NC	No Connection
Res	Reserved Pin

PRESENCE DETECT PINS (Optional)

Pin	50NS	60NS
PD1	NC	NC
PD2	NC	NC
PD3	V _{SS}	NC
PD4	V _{SS}	NC

* Pin connection changing available

SAMSUNG ELECTRONICS CO., LTD. reserves the right to change products and specifications without notice.



FUNCTIONAL BLOCK DIAGRAM

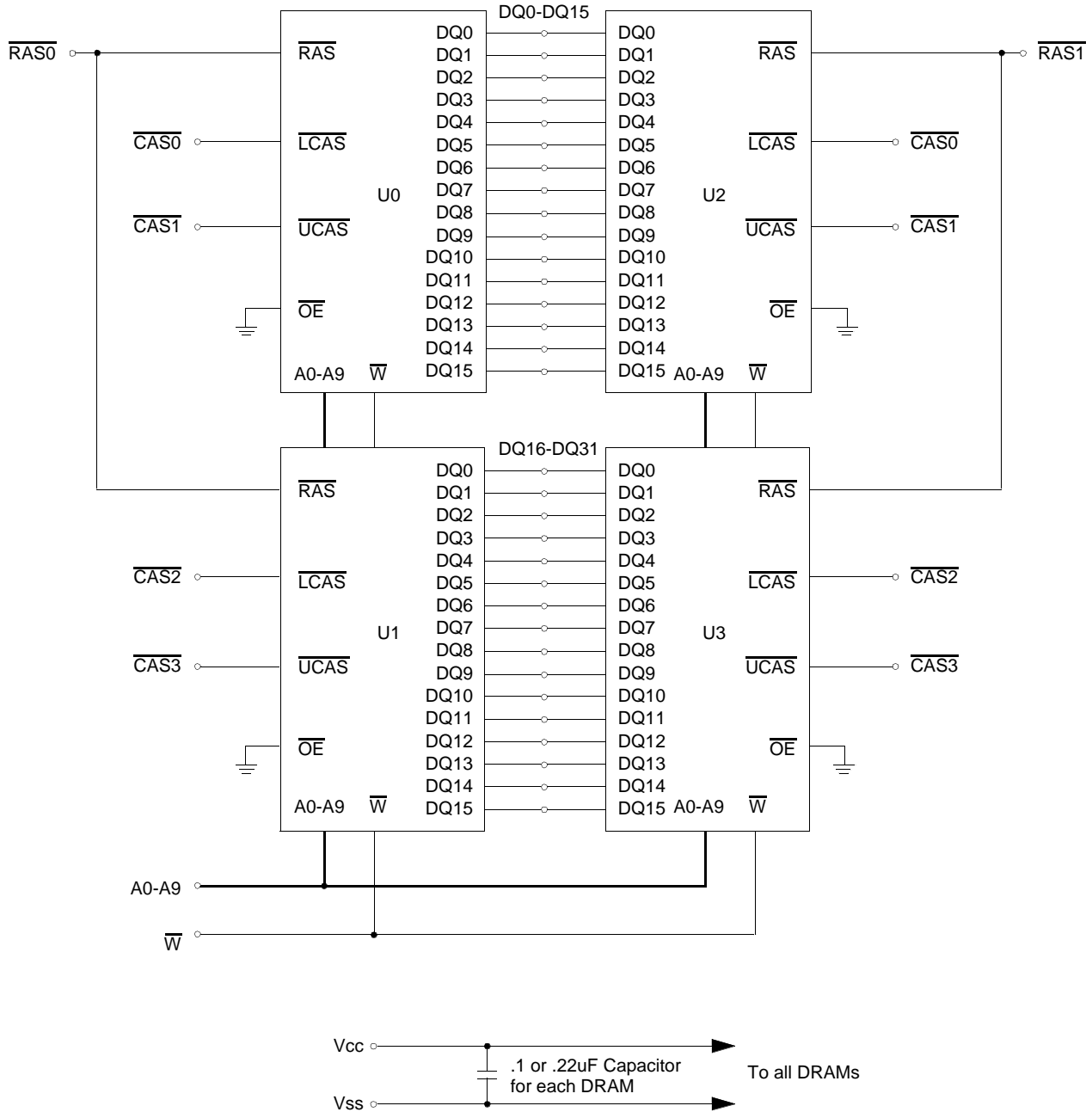

ABSOLUTE MAXIMUM RATINGS *

Item	Symbol	Rating	Unit
Voltage on any pin relative to V _{ss}	V _{IN} , V _{OUT}	-1 to +7.0	V
Voltage on V _{cc} supply relative to V _{ss}	V _{cc}	-1 to +7.0	V
Storage Temperature	T _{stg}	-55 to +150	°C
Power Dissipation	P _d	4	W
Short Circuit Output Current	I _{OS}	50	mA

* Permanent device damage may occur if ABSOLUTE MAXIMUM RATINGS are exceeded. Functional operation should be restricted to the conditions as detailed in the operational sections of this data sheet. Exposure to absolute maximum rating conditions for intended periods may affect device reliability.

RECOMMENDED OPERATING CONDITIONS (Voltage referenced to V_{ss}, T_A = 0 to 70°C)

Item	Symbol	Min	Typ	Max	Unit
Supply Voltage	V _{cc}	4.5	5.0	5.5	V
Ground	V _{ss}	0	0	0	V
Input High Voltage	V _{IH}	2.4	-	V _{cc} +1* ¹	V
Input Low Voltage	V _{IL}	-1.0* ²	-	0.8	V

*1 : V_{cc}+2.0V/20ns, Pulse width is measured at V_{cc}.

*2 : -2.0V/20ns, Pulse width is measured at V_{ss}.

DC AND OPERATING CHARACTERISTICS (Recommended operating conditions unless otherwise noted)

Symbol	Speed	KMM5322204C2W/C2WG		Unit
		Min	Max	
I _{cc1}	-5	-	304	mA
	-6	-	284	mA
I _{cc2}	Don't care	-	8	mA
I _{cc3}	-5	-	304	mA
	-6	-	284	mA
I _{cc4}	-5	-	244	mA
	-6	-	224	mA
I _{cc5}	Don't care	-	4	mA
I _{cc6}	-5	-	304	mA
	-6	-	284	mA
I _{I(L)}	Don't care	-20	20	uA
I _{O(L)}	Don't care	-10	10	uA
V _{OH}	Don't care	2.4	-	V
V _{OL}		-	0.4	V

I_{cc1} : Operating Current * (\overline{RAS} , \overline{CAS} , Address cycling @ t_{RC}=min)

I_{cc2} : Standby Current ($\overline{RAS}=\overline{CAS}=\overline{W}=V_{IH}$)

I_{cc3} : \overline{RAS} Only Refresh Current * ($\overline{CAS}=V_{IH}$, \overline{RAS} cycling @ t_{RC}=min)

I_{cc4} : EDO Mode Current * ($\overline{RAS}=V_{IL}$, \overline{CAS} cycling : t_{HPC}=min)

I_{cc5} : Standby Current ($\overline{RAS}=\overline{CAS}=\overline{W}=V_{cc}-0.2V$)

I_{cc6} : \overline{CAS} -Before- \overline{RAS} Refresh Current * (\overline{RAS} and \overline{CAS} cycling @ t_{RC}=min)

I_{I(L)} : Input Leakage Current (Any input 0 ≤ V_{IN} ≤ V_{cc}+0.5V, all other pins not under test=0 V)

I_{O(L)} : Output Leakage Current(Data Out is disabled, 0V ≤ V_{OUT} ≤ V_{cc})

V_{OH} : Output High Voltage Level (I_{OH} = -5mA)

V_{OL} : Output Low Voltage Level (I_{OL} = 4.2mA)

* **NOTE** : I_{cc1}, I_{cc3}, I_{cc4} and I_{cc6} are dependent on output loading and cycle rates. Specified values are obtained with the output open. I_{cc} is specified as an average current. In I_{cc1} and I_{cc3}, address can be changed maximum once while $\overline{RAS}=V_{IL}$. In I_{cc4}, address can be changed maximum once within one EDO mode cycle, t_{HPC}.

CAPACITANCE (TA = 25°C, VCC=5V, f = 1MHz)

Item	Symbol	Min	Max	Unit
Input capacitance[A0-A9]	CIN1	-	44	pF
Input capacitance[\overline{W}]	CIN2	-	48	pF
Input capacitance[$\overline{RAS0}$, $\overline{RAS1}$]	CIN3	-	40	pF
Input capacitance[$\overline{CAS0}$ - $\overline{CAS3}$]	CIN4	-	29	pF
Input/Output capacitance[$\overline{DQ0-31}$]	CDQ1	-	29	pF

AC CHARACTERISTICS (0°C≤TA≤70°C, VCC=5.0V±10%. See notes 1,2.)

Test condition : Vih/Vil=2.4/0.8V, Voh/Vol=2.0/0.8V, Output loading CL=100pF

Parameter	Symbol	-5		-6		Unit	Note
		Min	Max	Min	Max		
Random read or write cycle time	tRC	90		110		ns	
Access time from \overline{RAS}	tRAC		50		60	ns	3,4,10
Access time from \overline{CAS}	tCAC		15		17	ns	3,4,5
Access time from column address	tAA		25		30	ns	3,10
\overline{CAS} to output in Low-Z	tCLZ	3		3		ns	3
Output buffer turn-off delay from \overline{CAS}	tCEZ	3	13	3	15	ns	6,11,12
Transition time(rise and fall)	tT	2	50	2	50	ns	2
\overline{RAS} precharge time	tRP	30		40		ns	
\overline{RAS} pulse width	tRAS	50	10K	60	10K	ns	
\overline{RAS} hold time	tRSH	13		17		ns	
\overline{CAS} hold time	tCSH	40		50		ns	
\overline{CAS} pulse width	tCAS	8	10K	10	10K	ns	13
\overline{RAS} to \overline{CAS} delay time	tRCD	20	37	20	45	ns	4
\overline{RAS} to column address delay time	tRAD	15	25	15	30	ns	10
\overline{CAS} to \overline{RAS} precharge time	tCRP	5		5		ns	
Row address set-up time	tASR	0		0		ns	
Row address hold time	tRAH	10		10		ns	
Column address set-up time	tASC	0		0		ns	
Column address hold time	tCAH	8		10		ns	
Column address to \overline{RAS} lead time	tRAL	25		30		ns	
Read command set-up time	tRCS	0		0		ns	
Read command hold time referenced to \overline{CAS}	tRCH	0		0		ns	8
Read command hold time referenced to \overline{RAS}	tRRH	0		0		ns	8
Write command hold time	tWCH	10		10		ns	
Write command pulse width	tWP	10		10		ns	
Write command to \overline{RAS} lead time	tRWL	13		15		ns	
Write command to \overline{CAS} lead time	tCWL	13		10		ns	
Data-in set-up time	tDS	0		0		ns	9
Data-in hold time	tDH	8		10		ns	9
Refresh period	tREF		16		16	ms	
Write command set-up time	tWCS	0		0		ns	7
\overline{CAS} setup time(\overline{CAS} -before- \overline{RAS} refresh)	tCSR	5		5		ns	
\overline{CAS} hold time(\overline{CAS} -before- \overline{RAS} refresh)	tCHR	10		10		ns	
\overline{RAS} precharge to \overline{CAS} hold time	tRPC	5		5		ns	
Access time from \overline{CAS} precharge	tCPA		30		35	ns	3

AC CHARACTERISTICS (0°C ≤ T_A ≤ 70°C, V_{CC} = 5.0V ± 10%. See notes 1,2.)

Test condition : V_{ih}/V_{il} = 2.4/0.8V, V_{oh}/V_{ol} = 2.0/0.8V, Output loading CL = 100pF

Parameter	Symbol	-5		-6		Unit	Note
		Min	Max	Min	Max		
Hyper page mode cycle time	t _{HPC}	25		30		ns	13
$\overline{\text{CAS}}$ precharge time(Hyper page cycle)	t _{CP}	8		10		ns	
$\overline{\text{RAS}}$ pulse width(Hyper page cycle)	t _{RASP}	50	200K	60	200K	ns	
$\overline{\text{RAS}}$ hold time from $\overline{\text{CAS}}$ precharge	t _{RHCP}	30		35		ns	
$\overline{\text{W}}$ to $\overline{\text{RAS}}$ precharge time(C-B-R refresh)	t _{WRP}	10		10		ns	
$\overline{\text{W}}$ to $\overline{\text{RAS}}$ hold time(C-B-R refresh)	t _{WRH}	10		10		ns	
Output data hold time	t _{DOH}	5		5		ns	
Output buffer turn off delay from $\overline{\text{RAS}}$	t _{REZ}	3	13	3	15	ns	6,11,12
Output buffer turn off delay from $\overline{\text{W}}$	t _{WEZ}	3	13	3	15	ns	6,11
$\overline{\text{W}}$ to data delay	t _{WED}	15		15		ns	
$\overline{\text{W}}$ pulse width (Hyper Page Cycle)	t _{WPE}	5		5		ns	

NOTES

- An initial pause of 200us is required after power-up followed by any 8 $\overline{\text{RAS}}$ -only or $\overline{\text{CAS}}$ -before- $\overline{\text{RAS}}$ refresh cycles before proper device operation is achieved.
- V_{IH}(min) and V_{IL}(max) are reference levels for measuring timing of input signals. Transition times are measured between V_{IH}(min) and V_{IL}(max) and are assumed to be 5ns for all inputs.
- Measured with a load equivalent to 2 TTL loads and 100pF.
- Operation within the t_{RCd}(max) limit insures that t_{rac}(max) can be met. t_{RCd}(max) is specified as a reference point only. If t_{RCd} is greater than the specified t_{RCd}(max) limit, then access time is controlled exclusively by t_{CAc}.
- Assumes that t_{RCd} ≥ t_{RCd}(max).
- This parameter defines the time at which the output achieves the open circuit condition and is not referenced to V_{OH} or V_{OL}.
- t_{wcs} is non-restrictive operating parameter. It is included in the data sheet as electrical characteristics only. If t_{wcs} ≥ t_{wcs}(min), the cycle is an early write cycle and the data out pin will remain high impedance for the duration of the cycle.
- Either t_{rch} or t_{rrh} must be satisfied for a read cycle.
- These parameter are referenced to the $\overline{\text{CAS}}$ leading edge in early write cycles and to the $\overline{\text{W}}$ leading edge in read-write cycles.
- Operation within the t_{rad}(max) limit insures that t_{rac}(max) can be met. t_{rad}(max) is specified as reference point only. If t_{rad} is greater than the specified t_{rad}(max) limit, then access time is controlled by t_{AA}.
- t_{CEZ}(max), t_{REZ}(max), t_{WEZ}(max) and t_{OEZ}(max) define the time at which the output achieves the open circuit condition and are not referenced to output voltage level.
- If $\overline{\text{RAS}}$ goes to high before $\overline{\text{CAS}}$ high going, the open circuit condition of the output is achieved by $\overline{\text{CAS}}$ high going. If $\overline{\text{CAS}}$ goes to high before $\overline{\text{RAS}}$ high going, the open circuit condition of the output is achieved by $\overline{\text{RAS}}$ high going.
- t_{ASC} ≥ t_{CP min}

READ CYCLE

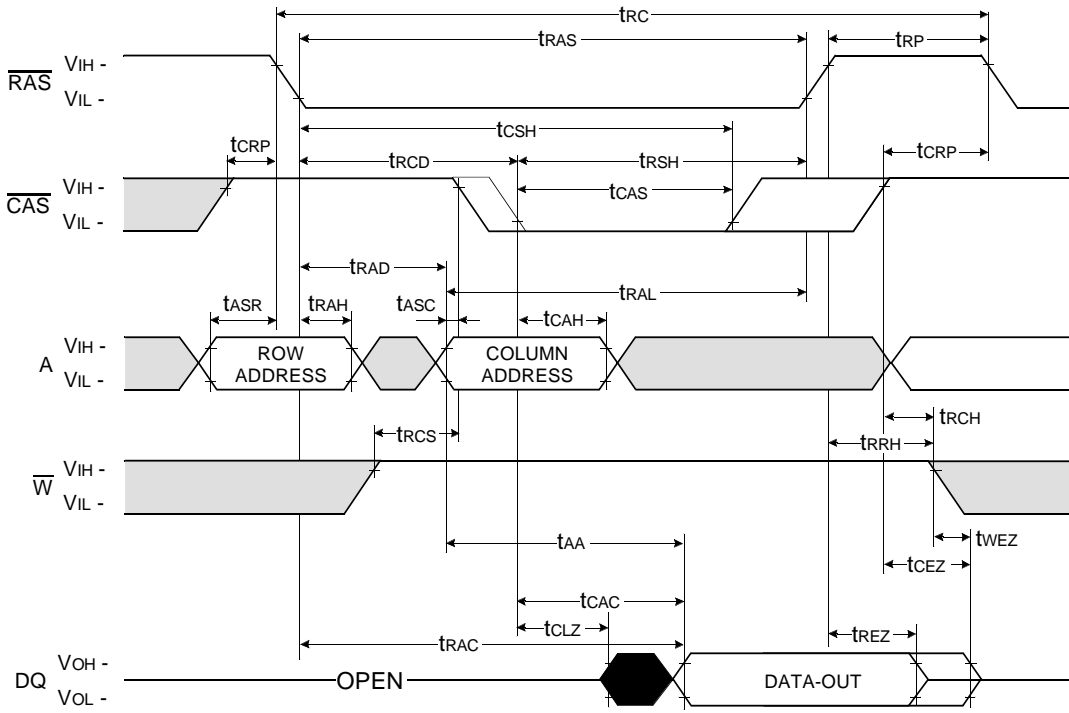

Don't care
 Undefined

HYPER PAGE WRITE CYCLE (EARLY WRITE)

NOTE : DOUT = OPEN

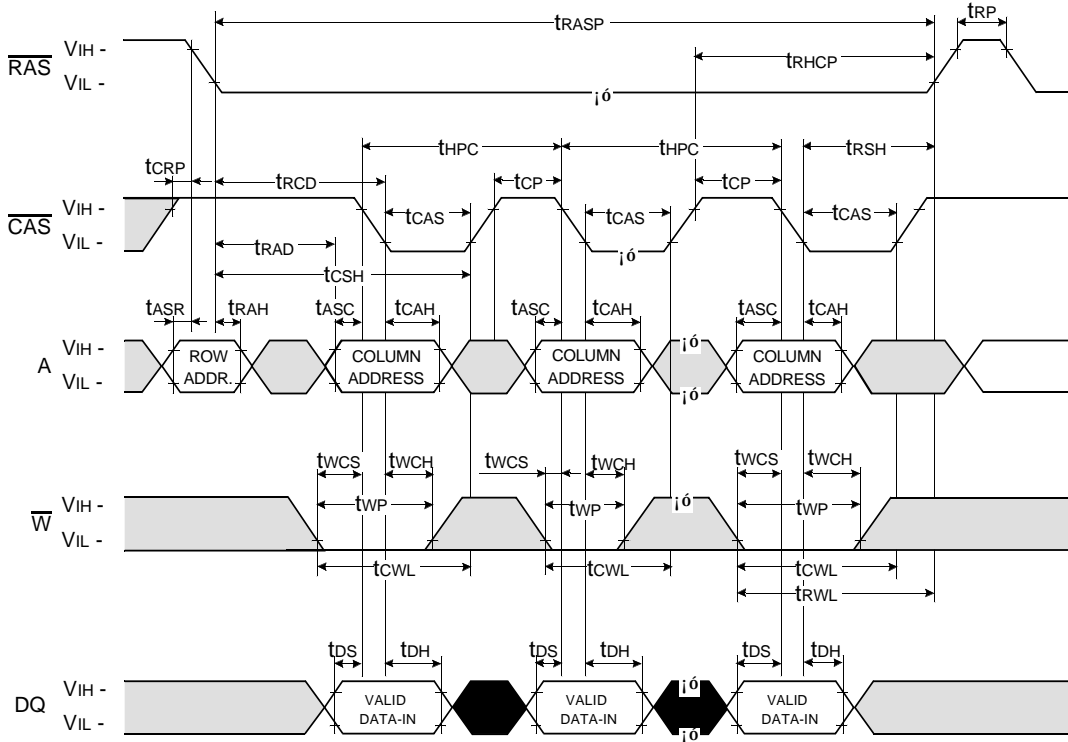

Don't care
 Undefined

$\overline{\text{RAS}}$ - ONLY REFRESH CYCLE*

NOTE : $\overline{\text{W}}$, $\overline{\text{OE}}$, DIN = Don't care

DOUT = OPEN

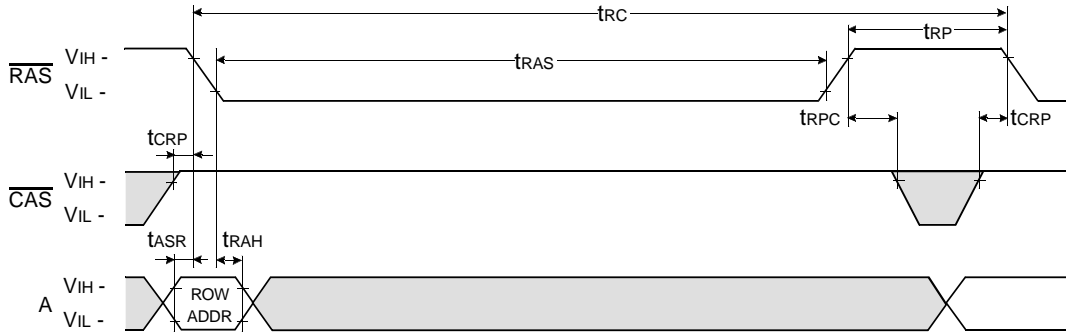

$\overline{\text{CAS}}$ - BEFORE - $\overline{\text{RAS}}$ REFRESH CYCLE

NOTE : $\overline{\text{OE}}$, A = Don't care

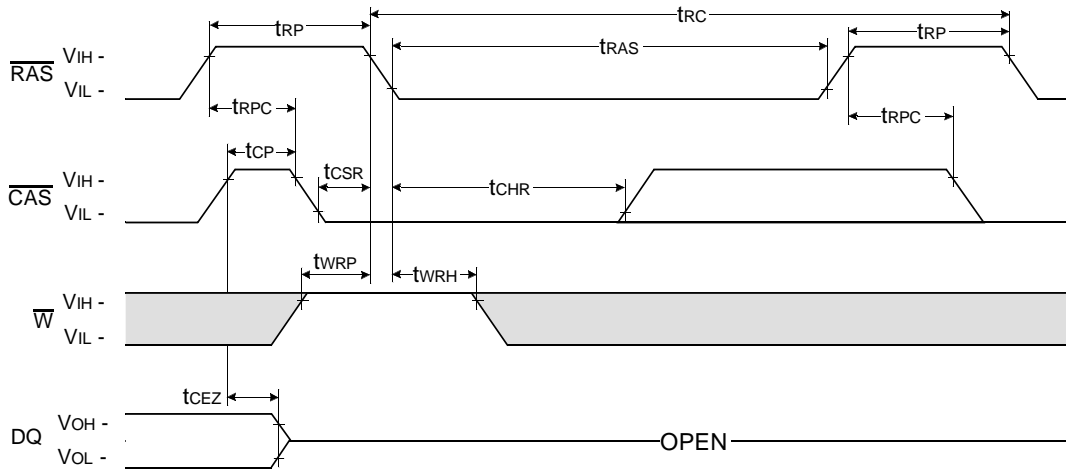

Don't care

Undefined

* In $\overline{\text{RAS}}$ -only refresh cycle of 64Mb A-die & B-die, when $\overline{\text{CAS}}$ signal transits from Low to High, the valid data may be cut off.

HIDDEN REFRESH CYCLE (READ)

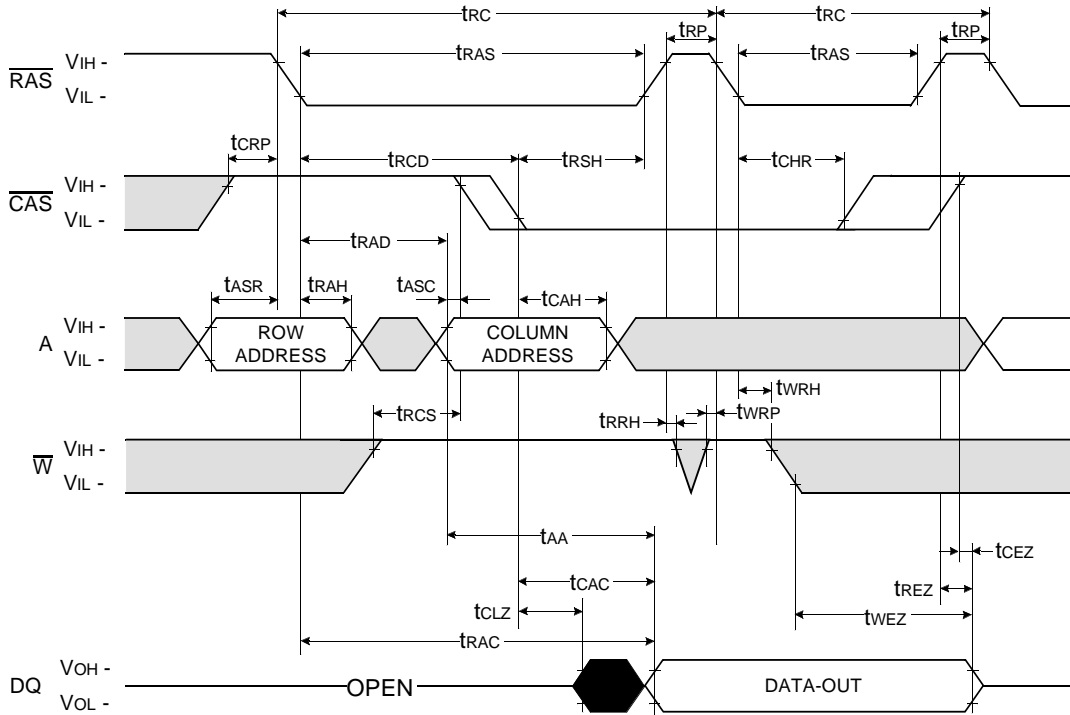

Don't care
 Undefined

HIDDEN REFRESH CYCLE (WRITE)

NOTE : DOUT = OPEN

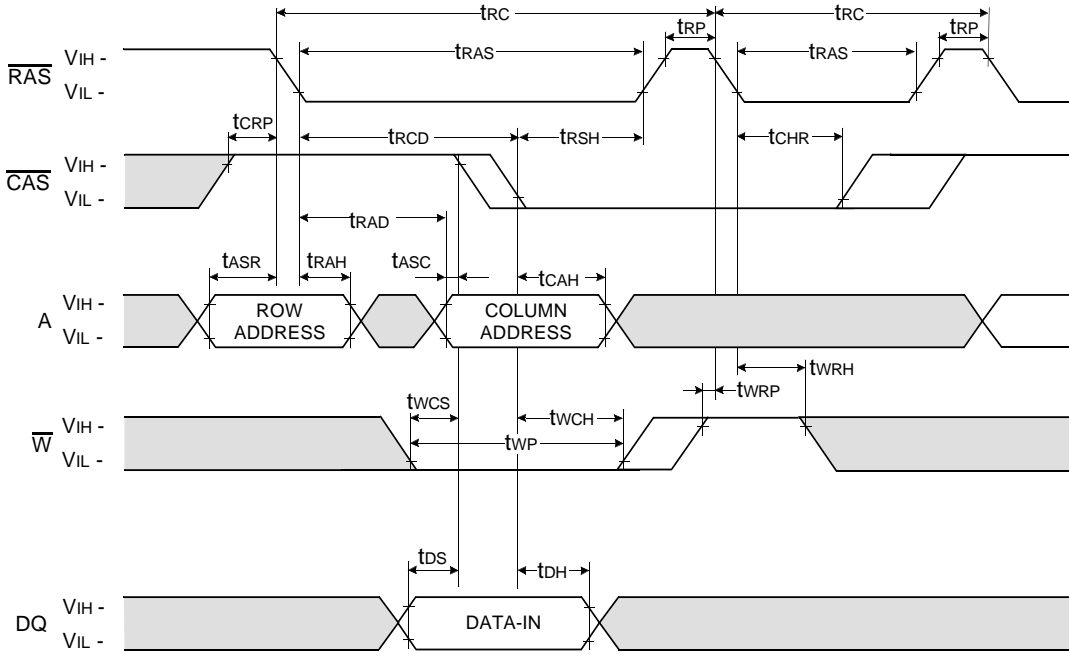

Don't care
 Undefined

CAS-BEFORE-RAS REFRESH COUNTER TEST CYCLE

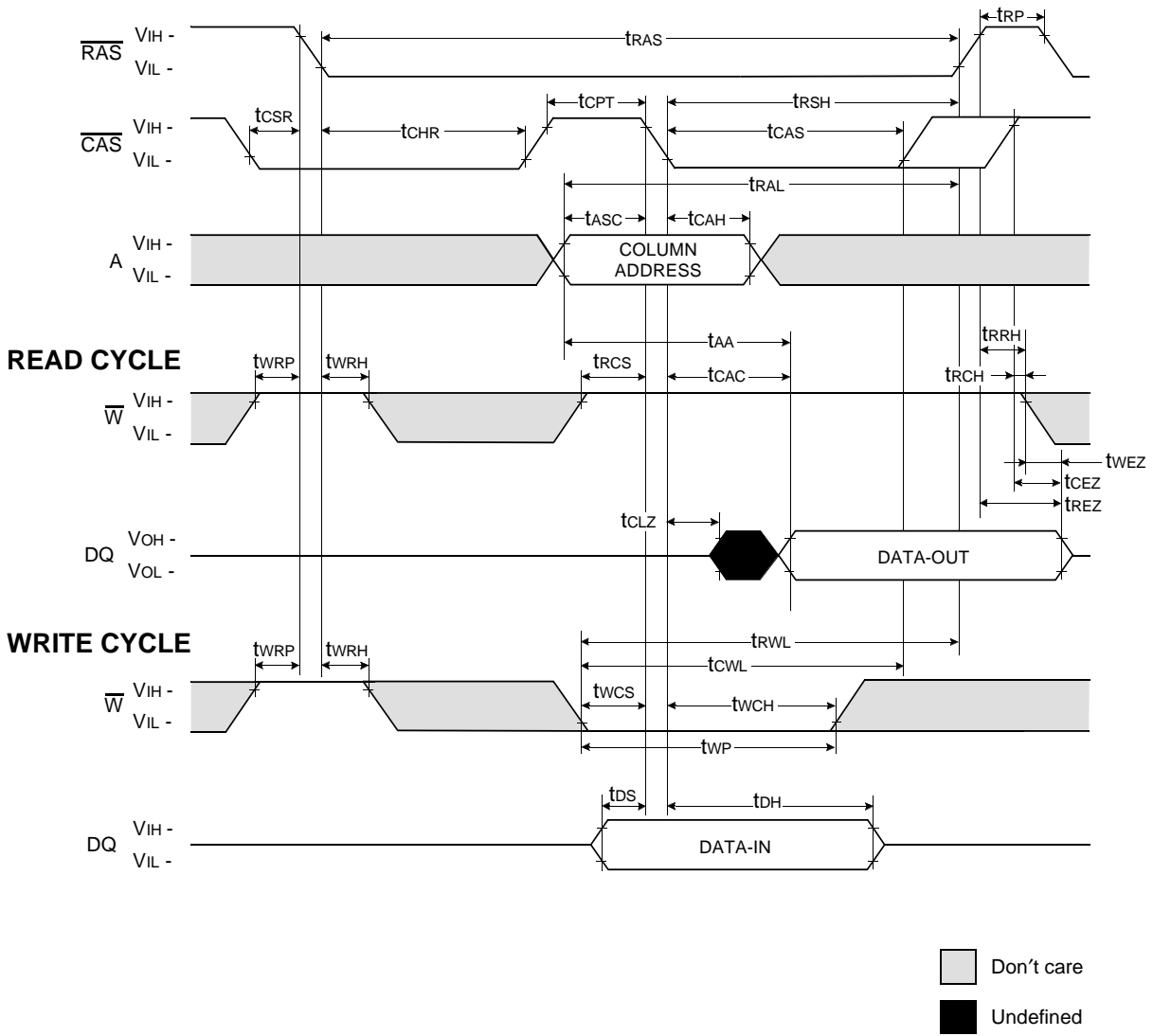

NOTE : This timing diagram is applied to all devices besides 64M DRAM based modules.

CAS - BEFORE - RAS SELF REFRESH CYCLE

NOTE : \overline{OE} , A = Don't care

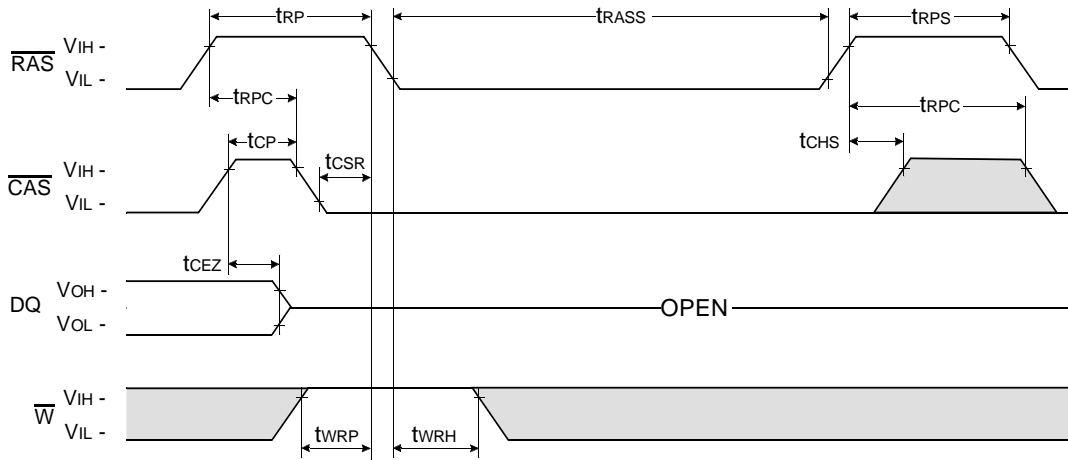

TEST MODE IN CYCLE

NOTE : \overline{OE} , A = Don't care

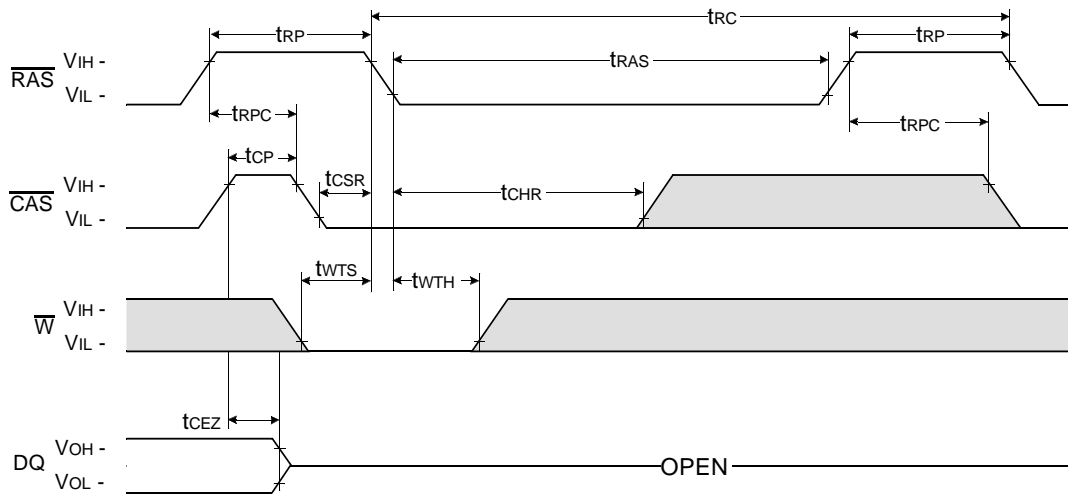

Don't care
 Undefined

DRAM MODULE

KMM5322204C2W/C2WG

PACKAGE DIMENSIONS

Units : Inches (millimeters)

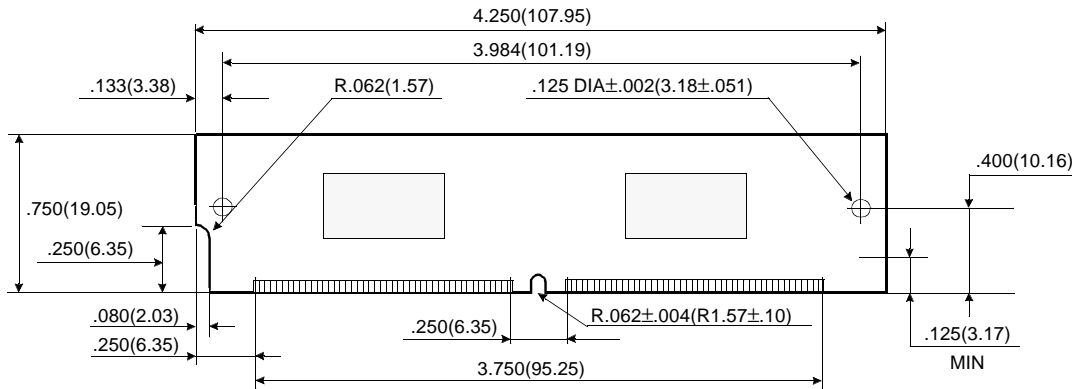

(Front view)

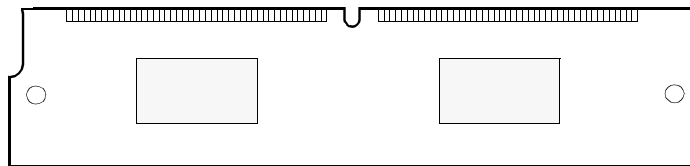

(Back view)

Gold & Solder Plating Lead

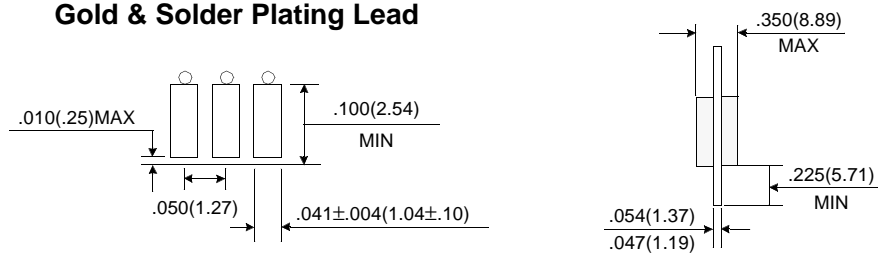

Tolerances : $\pm .005$ (.13) unless otherwise specified

NOTE : The used device is 1Mx16 DRAM

DRAM Part No. : KMM5322204C2W/C2WG -- KM416C1204CJ (400 mil)

Revision History
Rev 0.0 : Nov. 1997