

Relay Modules for Compact FieldPoint

NI cFP-RLY-421, NI cFP-RLY-423

- 4 or 8 electromechanical relays
- 8 form A (SPST), RLY-421
- 4 form C (SPDT), RLY-423
- Switch 250 VAC, 120 VDC
- Switch 1.5 A, maximum
- 2,300 V_{rms} bank isolation for transient overvoltage protection
- Hot swappable with autoconfiguration
- -40 to 55 °C operating range (cFP-RLY-421)
- -40 to 60 °C operating range (cFP-RLY-423)

NEW



Module	Output Channels	Maximum Output Types	Output Current Rating (See Specifications)	Separate Ground Plane per Channel
cFP-RLY-421	8	120 VDC, 250 VAC	1.5 A	✓
cFP-RLY-423	4	120 VDC, 250 VAC	1.5 A	✓

Overview

The National Instruments cFP-RLY-42x devices are versatile relay modules for Compact FieldPoint that can be used to control digital signals ranging from low voltage to 120 VDC and to 250 VAC. These modules are commonly used to control indicator lights, motors, and power circuits. All the modules include onboard diagnostics to ensure trouble-free installation and maintenance. Similar relay modules are available for FieldPoint, see page 572 for more information.

Relay Modules

NI cFP-RLY-42x modules provide built-in module-to-module isolation to protect your Compact FieldPoint system and controller from high voltage levels. Each channel on the RLY-42x uses electrically isolated output relays so that each relay output has a separate ground plane and each channel can be used with a different voltage potential. Thus, you can connect one channel to a 24 VDC and another channel on the same module to a 250 VAC.

All the channels on the relay modules feature LEDs that indicates the output state of each channel. The modules all feature a maximum switching frequency of 10 Hz (20 operations). Overall data throughput depends on software loop speeds and network speeds.

Isolation

The cFP-RLY-42x modules feature optical bank isolation with 2,300 V_{rms} of breakdown isolation. In addition, the modules provide double insulation for up to 250 V_{rms} of operational isolation. Compact FieldPoint can safely be used in applications where hazardous voltages are present with the cFP-CB-1 connector block. These Compact FieldPoint modules do not have channel-to-channel isolation.

Power Requirements

Because the cFP-RLY-42x are high power consumption modules, they could limit the number of I/O modules that you can connect to a single network interface module. Controllers and network interface modules supply up to 9 W to power I/O modules. The RLY-421 requires up to 2.5 W and the RLY-423 requires up to 1.5 W.

Field I/O Connections

Each input channel on the cFP-RLY-421 has two terminals:

1. Relay common terminal (IC)
2. Normally open terminal (NO)

Each channel of the cFP-RLY-423 has three terminals:

1. Normally open terminal (NO)
2. Normally closed terminal (NC)
3. Relay common terminal (IC)

Relay Modules for Compact FieldPoint

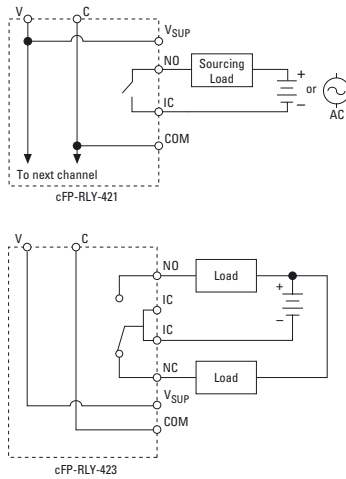

Figure 1. Wiring Schematics for RLY Modules

Ordering Information

NI cFP-RLY-421	777318-421
NI cFP-RLY-423	777318-423

Recommended Compact FieldPoint System Products

NI cFP-2020	777317-2020
NI cFP-BP-4	778617-04
NI cFP-CB-1	778618-01
NI PS-5 Power Supply	778805-90
NI Developer Suite Professional Control Edition	777906-03

BUY ONLINE!

Visit ni.com/info and enter *cfprly421*, and/or *cfprly423*.

Specifications

Typical for -40 to 60 °C unless otherwise noted.

Relay Characteristics

Number of channels	
cFP-RLY-421	8
cFP-RLY-423	4
Relay type	
cFP-RLY-421	SPST, normally open, nonlatching
cFP-RLY-423	SPDT, nonlatching
Maximum switching capacity (resistive load)	
AC	1.5 A at 250 VAC
DC	1.5 A at 0-35 VDC
(cFP-RLY-421)	1.5 A at 40 VDC
(cFP-RLY-423)	1 A at 55 VDC
	0.4 A at 120 VDC
Minimum switching load	10 mA at 5 VDC
Off-state leakage current	(120 VDC/250 VAC)
DC	0.12 µA
50/60 Hz	8 µA
On resistance (typical)	100 mΩ
Expected relay life	
Mechanical	2 x 10 ⁷ operations/s (cFP-RLY-421) 1 x 10 ⁷ operations/s (cFP-RLY-423)
Electrical (at 30 cpm)	300,000 operations at 1.5 A, 35 VDC 100,000 operations at 1.5 A, 250 VAC
Operate time	
cFP-RLY-421	<10 ms
cFP-RLY-423	<10 ms typ, 13 ms max
Release time	
cFP-RLY-421	<10 ms
cFP-RLY-423	5 ms typ, 7 ms max
Bounce time	
cFP-RLY-421	10 ms max
cFP-RLY-423	3 ms typ, 6 ms max
Contact material	
cFP-RLY-421	Gold-plated silver cadmium oxide
cFP-RLY-423	Silver cadmium oxide

Power Requirement (from Network Module)

cFP-RLY-421	1.95 W
cFP-RLY-423	1.0 W

Physical Characteristics

LED indicators	
Power (green)	Indicates power is on and self-test passed
Ready (green)	Indicates module is configured and ready

<0..7> or <0..3>	Indicates on/off state of each contact
Dimensions (including terminal base)	10.9 by 10.9 by 9.1 cm (4.3 by 4.3 by 3.6 in.)
Weight	
cFP-RLY-421	136 g (4.8 oz)
cFP-RLY-423	156 g (5.5 oz)

Isolation Voltage

Maximum isolation voltage	250 V _{rms} , Installation Category II
Channel-to-channel isolation	No isolation between channels
Transient overvoltage	2,300 V _{rms}

Environmental

FieldPoint modules are intended for indoor use only. For outdoor use, they must be mounted inside a sealed enclosure.	
Operating temperature	-40 to 60 °C
Storage temperature	-55 to 85 °C
Relative humidity	10 to 90%, noncondensing
Maximum altitude	2,000 m; at higher altitudes the isolation voltage ratings must be lowered.
Pollution Degree	2

Safety

This product is designed to meet the requirements of the following standards of safety for electrical equipment for measurement, control, and laboratory use:

- IEC 61010-1, EN 61010-1
- UL 3121-1, UL 61010C-1
- CAN/CSA C22.2 No. 1010.1

For UL, hazardous location, and other safety certifications, refer to the product label or to ni.com

Electromagnetic Compatibility

CE, C-Tick, and FCC Part 15 (Class A) Compliant	
Emissions	EN 55011 Class A at 10 m
FCC Part 15A above 1 GHz	
Immunity	EN 61326:1997 +A2:2001, Table 1

For EMC compliance, you must operate this device with shielded cabling.

CE Compliance

This product meets the essential requirements of applicable European Directives, as amended for CE Marking, as follows:

Low-Voltage Directive (safety)	73/23/EEC
Electromagnetic Compatibility Directive (EMC)	89/336/EEC

Refer to the Declaration of Conformity (DoC) for this product for any additional regulatory compliance information. To obtain the DoC for this product, visit ni.com/hardref.nsf and search by model number or product line.

Global Services and Support

NI has the services and support to meet your needs around the globe and through the application life cycle – from planning and development through deployment and ongoing maintenance – and tailored for customer requirements in research, design, validation, and manufacturing. We have direct operations in more than 37 countries and distributors in another 12 locations. Our local sales and support representatives are degreed engineers, ready to partner with you to find solutions that best fit your needs.

Local Sales and Technical Support

In offices around the globe, our staff is local to the country so that you have access to field engineers who speak your language and are available to consult on your unique needs. We also have a worldwide support organization staffed with Applications Engineers trained to quickly provide superior technical assistance. Use our online Request Support interface (ni.com/support) to define your question, then speak to or e-mail an Applications Engineer, or access more than 14,000 worldwide measurement and automation professionals within NI Developer Exchange Discussion Forums. ni.com/support also provides immediate answers to your questions through self-help troubleshooting, product reference, and application development resources. For advanced technical support and software maintenance services, sign up for Premier Support, a program that provides expanded hours of support availability and expedited phone/e-mail response time (typically four business hours).

Training and Certification

NI recognizes that both initial instruction and ongoing education contribute to your success. NI provides a variety of training alternatives, from self-paced tutorials and interactive CDs, to worldwide hands-on courses taught by experienced instructors – all designed so that you can choose how to learn about our products. Further, NI offers certifications acknowledging individual expertise in working with NI products and technologies. Visit ni.com/training for more information.

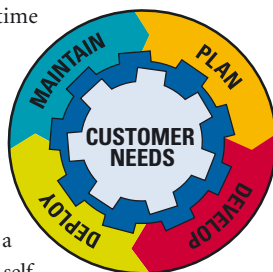

Professional Services

Our Professional Services team consists of National Instruments Applications Engineers, NI Consulting Services, and the worldwide National Instruments Alliance Partner Program (a network of 600 independent consultants and integrators). Our Professional Services team can offer services ranging from basic start-up assistance and collaborative development with your engineers, to turnkey system integration and maintenance of your system.



In addition to our NI Alliance Partners, we have developed global relationships with many industry partners that range from computer software and hardware companies, such as Microsoft, Dell, Siemens, and Tektronix. By collaborating with these companies, you receive a complete spectrum of solutions – from components to turnkey systems. Find the Alliance Partner directory at ni.com/alliance

Product Services

NI hardware products are warranted against defects in workmanship and material for one year from the date of shipment. To help you meet project life-cycle requirements, NI offers extended warranties for an additional charge. NI provides complete repair services for our products. Express repair and advanced replacement services are also available. Or, order your software and hardware installed in PXI and PXI/SCXI™ systems with NI Factory Installation Services.

Ordering Made Easy

Visit ni.com/products to browse product specifications, make comparisons, or access technical representatives via online chat or telephone. Worldwide customers can use a purchase order or credit card to buy in local currency and receive direct shipments from local NI offices. Our North American Customer Service Representatives are available Monday through Friday between 7 a.m. and 7 p.m. Central Time. Outside North America, please contact the NI office in your country.

Order Status and Service Requests

National Instruments brings you real-time status on current orders at ni.com/status. Similarly, find out the status of open technical support incidents or hardware repair requests at ni.com/support/servicereq



ni.com • (800) 433-3488

National Instruments • Tel: (512) 683-0100 • Fax: (512) 683-9300 • info@ni.com

© 2003 National Instruments Corporation. All rights reserved. Product and company names listed are trademarks or trade names of their respective companies.