

# MF1173V-1

FOR GSM MOBILE TELEPHONE, Tx

MF1173V-1

## DESCRIPTION

This SAW filter for the transmitting RF circuit of GSM mobile communication equipment operating at 890 MHz - 915 MHz.

## FEATURES

1. SMD package insures small size, lightweight.
2. Adjustment free.
3. Low insertion loss and high stop band attenuation.
4. Wide and sharp passband characteristics.
5. High stability and reliability.
6. Designed for reflow solderings.

## APPLICATION

- Mobile Cellular Telephone
- Portable Cellular Telephone
- Wireless equipment

## MAXIMUM RATINGS

Rating	Value	Unit
Input Power	50	mW
Operating Temperature Range	-20 to 75	°C
Storage Temperature Range	-30 to 85	°C

## ELECTRICAL PERFORMANCE

Parameter	MF1173V-1			Units
	Min	Typ	Max	
PASSBAND FREQUENCY	890 - 915			MHz
PASSBAND CHARACTERISTICS	Insertion Loss	3.0	3.8	dB
	Ripple	0.8	1.5	dBp-p
	VSWR	1.9	2.5	
STOPBAND ATTENUATION	0 - 820 MHz	40	45	dB
	820 - 860 MHz	35	43	dB
	935 - 990 MHz	20	27	dB
	990 - 1200 MHz	45	58	dB

## PACKAGE OUTLINE DIMENSIONS

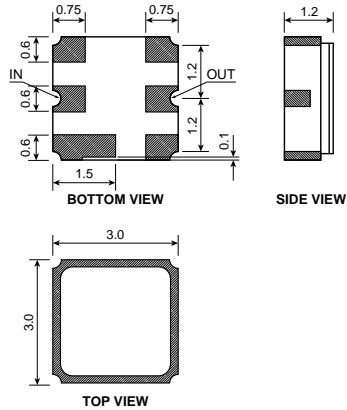

Unit : mm

DIMENSIONS ARE IN MILLIMETERS  
±0.2 UNLESS OTHERWISE SPECIFIED

## MF1173V-1 TYPICAL CHARACTERISTICS

