Features

- 32-kHz Oscillator
- 1.3 V to 1.8 V Operating-voltage Range
- 180 nA Typical Current Consumption
- Voltage Regulator
- Integrated Capacitors, Mask Selectable
- Mask Options for Pad Designation, Motor Period and Motor Pulse Width
- Low Resistance Outputs for Bipolar Stepping Motor
- Motor Fast-test Function

Description

The e1217X is an integrated circuit in CMOS silicon gate technology for analog watches. It consists of a 32-kHz oscillator, frequency dividers down to 1/64 Hz, output pulse formers and push-pull motor drivers. Integrated capacitors are provided (selectable mask option) for tuning of the crystal. Low current consumption and high oscillator stability are enabled by an on-chip voltage regulator.



**32-kHz
Standard Watch
CMOS IC**

e1217X

4728A-CLOCK-06/03



Pad Configuration

Figure 1. Pinning

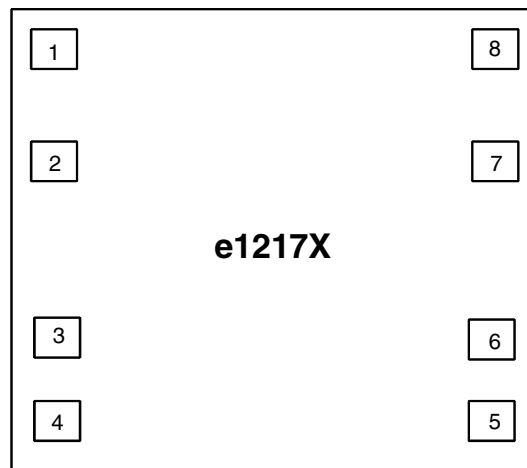

Chip size 1.06 mm × 1.02 mm
 Pad size: 112 μm × 112 μm
 Pad window: 100 μm × 100 μm

Pin Description

Pin	Symbol	Function
1, 4	V_{SS}	Negative supply voltage
5, 6, 8	V_{DD}	Positive supply voltage
1 to 4	OSCIN/OSCOU	Oscillator input/output
(7/5) or (7/6)	MOT 1/2	Motor drive outputs
1 to 5, 8	RESET	Reset input
1 to 5, 8	TEST	Test input/output

Functional Description

Voltage Regulator

An integrated voltage regulator provides the oscillator with a well-controlled negative supply voltage V_{REG} . This improves the stability of the oscillator and keeps current consumption at a minimum.

Oscillator

The oscillator inverter with feedback resistor generates the 32768 Hz clock frequency. A total capacitance of 24 pF is integrated. This can be selected for COSCOUT in 2 pF increments via a mask option.

Frequency Divider

A 21-bit binary counter is provided, dividing the oscillator frequency down to 1/64 Hz. The leading six stages are connected to V_{DD} and V_{REG} , while the remaining 15 stages are connected to V_{DD} and V_{SS} .

Motor Drive Output

The e1217X contains two push-pull output buffers for driving bipolar stepping motors. During a motor pulse, the n-channel device of one buffer and the p-channel device of the other buffer are activated. The p-channel devices of both buffers are active (see Figure 3) between the two pulses.

Cycle time and pulse width can be chosen via a metal mask option (Table 1).

RESET

A debounced RESET input is provided. Connecting the RESET input to V_{DD} resets the 12 low-order stages of the frequency divider, thus disabling further motor pulses. Motor pulses, which are in progress when the reset function is applied, will be completed. After releasing the RESET pad from V_{DD} , the next motor pulse appears with a delay of one half motor cycle on the drive output opposed to the former (Figure 4). Due to the debounce circuitry on the RESET input, V_{DD} must be applied for at least 31.2 ms. During RESET the input current is limited to 8 nA typically.

Test

A test frequency of 512 Hz is output to this pad which can be measured with a high resistance probe ($R \geq 10 \text{ M}\Omega$, $C \geq 20 \text{ pF}$). This signal can be used for testing and tuning the oscillator. Connecting TEST to V_{DD} for at least 4 ms changes the motor cycle time from the selected value to the test cycle time (mask options), while the motor pulse width remains unchanged (Figure 3).

This feature can be used to reduce the amount of time required for testing the mechanical parts of the watch.

Table 1. Motor Options

Motor-cycle Parameters	Value
Cycle time T_M	2, 4, 6, 8, 10, 12, 20, 24, 30, 40, 60, 80, 120 s
Motor pulse width t_M	0.98 to 14.65 ms in increments of 0.98 ms
Motor test cycle time T_{MT}	250, 125, 62.5 ms

Absolute Maximum Ratings

Absolute maximum ratings define parameter limits which, if exceeded, may permanently change or damage the device.

All inputs and outputs on Atmel's circuits are protected against electrostatic discharges. However, precautions to minimize the build-up of electrostatic charges during handling are recommended.

The circuit is protected against supply-voltage reversal for typically 5 minutes.

Parameters	Symbol	Value	Unit
Supply voltage	V_{SS}	-0.3 to +5	V
Input voltage range, all inputs	V_{IN}	$(V_{SS} - 0.3 V) \leq V_{IN} \leq (V_{DD} + 0.3 V)$	V
Output short-circuit duration		indefinite	
Power dissipation (DIL package)	P_{tot}	125	mW
Operating ambient temperature range	T_{amb}	-20 to +70	°C
Storage temperature range	T_{stg}	-40 to +125	°C
Lead temperature during soldering at 2 mm distance, 10 s	T_{sld}	260	°C

Operating Characteristics

$V_{DD} = 0 V$; $V_{SS} = -1.55 V$; $T_{amb} = +25^{\circ}C$; $C_{TR} = 15 pF$, unless otherwise specified.

All voltage levels are measured with reference to V_{DD} . Test crystal as specified below.

Parameters	Test Conditions	Symbol	Min.	Typ. ⁽¹⁾	Max.	Unit
Operating voltage	Functional test (Figure 2)	V_{SS}	-1.3		-1.8	V
Operating current	$C_{oscout} = 16 pF$, $R_L = R$	I_{SS}		-180	-300	nA
RESET input current	RESET = V_{DD}	I_R		8		nA
Motor Outputs						
Motor output current	$R_L = 2 k\Omega$, $V_{SS} = -1.55 V$	I_M	± 0.7			mA
Motor period		T_M	See Table 2			s
Motor pulse width		T_M	See Table 2			ms
Motor test period		T_{MT}	See Table 2			ms
Oscillator						
Stability	$\Delta V_{SS} = 100 mV$, $C_{TR} = 5 pF$	$\Delta f/f$		0.1		ppm
Start-up voltage	Startup within 2 s	V_{ST}	-1.3			V
Integrated input capacitor		$C_{OSC IN}$	See Table 2			pF
Integrated output capacitor	$C_{OSCOUTmax} = 24 pF$	$C_{OSC OUT}$	See Table 2			pF

Note: 1. Typical parameters represent the statistical mean values.

Figure 2. Functional Test Circuit

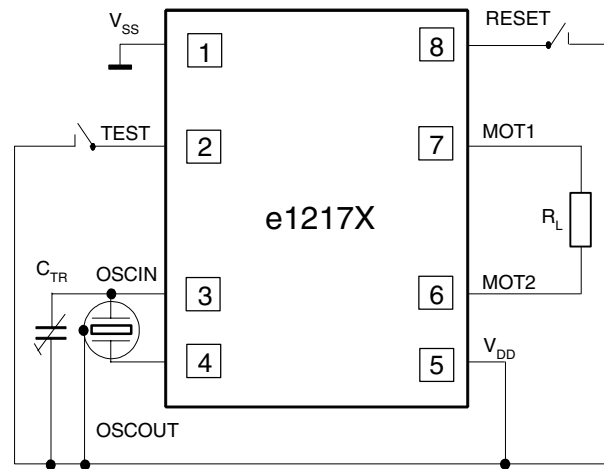

Range of trimmer capacitance: $C_{TR} = 5 \text{ pF to } 30 \text{ pF}$

Test Crystal Specification

Frequency	$f = 32,768 \text{ Hz}$
Series resistance	$R_S = 30 \text{ k}\Omega$
Static capacitance	$C_0 = 1.5 \text{ pF}$
Dynamic capacitance	$C_1 = 3 \text{ fF}$
Load capacitance	$C_L = 8 \text{ pF}$

Additional Notes

1. It is recommended to connect the quartz case to V_{DD} (by conductive epoxy).
2. Capacitive coupling of TEST to OSCIN must be minimized by appropriate layout of the PCB to avoid disturbing the oscillator.

Figure 3. Motor Drive Outputs in Normal Mode and Motor Test

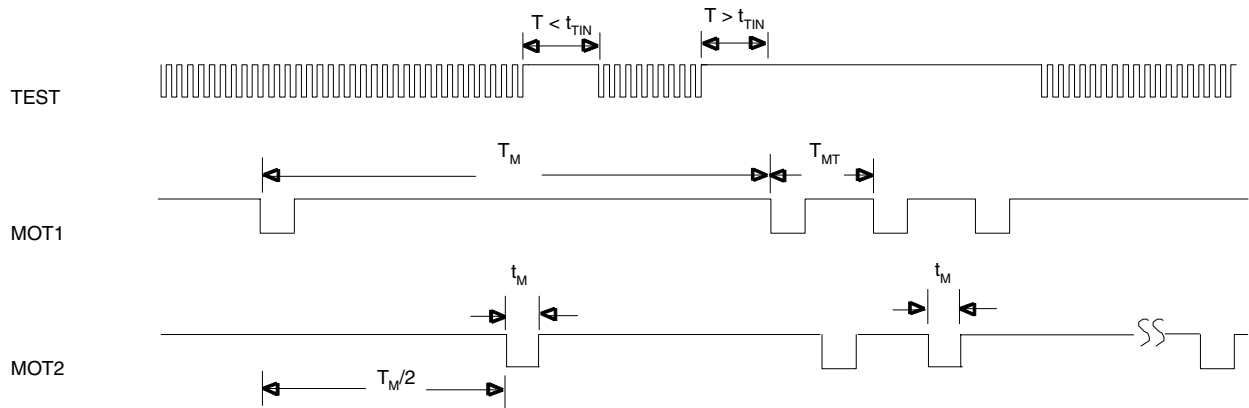
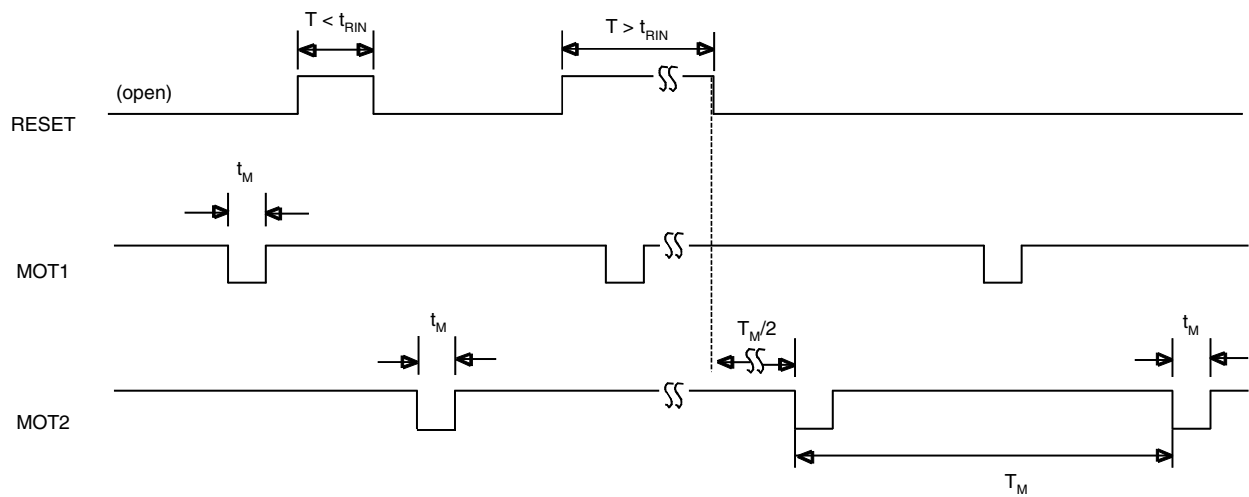

Figure 4. Motor Drive Outputs and RESET



Ordering Information

Table 2. Option List e1217X

Option	Motor			Integrated Capacitance ⁽¹⁾		Pad 1	Pad 2	Pad 3	Pad 4	Pad 5	Pad 6	Pad 7	Pad 8
	Cycle (T _M) s	Pulse (t _M) ms	Test (T _{MT}) ms	C _{OSCIN} pF	C _{OSCOUT} pF								
-B	2	3.9	125	2	14	V _{SS}	TEST	OSCIN	OSCOUT	V _{DD}	MOT2	MOT1	RESET
-S	2	5.9	125	2	14	V _{SS}	TEST	OSCIN	OSCOUT	V _{DD}	MOT2	MOT1	RESET
-T	10	3.9	125	2	14	V _{SS}	TEST	OSCIN	OSCOUT	V _{DD}	MOT2	MOT1	RESET
-VA	2	4.9	62.5	4	14	V _{SS}	TEST	OSCOUT	OSCIN	V _{DD}	MOT2	MOT1	RESET
-VB	2	4.9	125	4	14	OSCIN	OSCOUT	RESET	V _{SS}	TEST	MOT2	MOT1	V _{DD}
-VC	40	5.9	125	2	14	OSCIN	OSCOUT	RESET	V _{SS}	TEST	MOT2	MOT1	V _{DD}
-VF	2	3.9	62.5	4	14	OSCIN	OSCOUT	RESET	V _{SS}	MOT2	VDD	MOT1	TEST
-VH	2	3.9	62.5	4	14	V _{SS}	TEST	OSCOUT	OSCIN	V _{DD}	MOT2	MOT1	RESET
-WB	2	4.9	125	4	14	V _{SS}	TEST	OSCIN	OSCOUT	V _{DD}	MOT2	MOT1	RESET

Note: 1. On-chip stray capacitance included



Atmel Corporation

2325 Orchard Parkway
San Jose, CA 95131
Tel: 1(408) 441-0311
Fax: 1(408) 487-2600

Regional Headquarters

Europe

Atmel Sarl
Route des Arsenalux 41
Case Postale 80
CH-1705 Fribourg
Switzerland
Tel: (41) 26-426-5555
Fax: (41) 26-426-5500

Asia

Room 1219
Chinachem Golden Plaza
77 Mody Road Tsimshatsui
East Kowloon
Hong Kong
Tel: (852) 2721-9778
Fax: (852) 2722-1369

Japan

9F, Tonetsu Shinkawa Bldg.
1-24-8 Shinkawa
Chuo-ku, Tokyo 104-0033
Japan
Tel: (81) 3-3523-3551
Fax: (81) 3-3523-7581

Atmel Operations

Memory

2325 Orchard Parkway
San Jose, CA 95131
Tel: 1(408) 441-0311
Fax: 1(408) 436-4314

Microcontrollers

2325 Orchard Parkway
San Jose, CA 95131
Tel: 1(408) 441-0311
Fax: 1(408) 436-4314

La Chantrerie
BP 70602
44306 Nantes Cedex 3, France
Tel: (33) 2-40-18-18-18
Fax: (33) 2-40-18-19-60

ASIC/ASSP/Smart Cards

Zone Industrielle
13106 Rousset Cedex, France
Tel: (33) 4-42-53-60-00
Fax: (33) 4-42-53-60-01

1150 East Cheyenne Mtn. Blvd.
Colorado Springs, CO 80906
Tel: 1(719) 576-3300
Fax: 1(719) 540-1759

Scottish Enterprise Technology Park
Maxwell Building
East Kilbride G75 0QR, Scotland
Tel: (44) 1355-803-000
Fax: (44) 1355-242-743

RF/Automotive

Theresienstrasse 2
Postfach 3535
74025 Heilbronn, Germany
Tel: (49) 71-31-67-0
Fax: (49) 71-31-67-2340

1150 East Cheyenne Mtn. Blvd.
Colorado Springs, CO 80906
Tel: 1(719) 576-3300
Fax: 1(719) 540-1759

Biometrics/Imaging/Hi-Rel MPU/ High Speed Converters/RF Datacom

Avenue de Rochepleine
BP 123
38521 Saint-Egreve Cedex, France
Tel: (33) 4-76-58-30-00
Fax: (33) 4-76-58-34-80

e-mail

literature@atmel.com

Web Site

<http://www.atmel.com>

Disclaimer: Atmel Corporation makes no warranty for the use of its products, other than those expressly contained in the Company's standard warranty which is detailed in Atmel's Terms and Conditions located on the Company's web site. The Company assumes no responsibility for any errors which may appear in this document, reserves the right to change devices or specifications detailed herein at any time without notice, and does not make any commitment to update the information contained herein. No licenses to patents or other intellectual property of Atmel are granted by the Company in connection with the sale of Atmel products, expressly or by implication. Atmel's products are not authorized for use as critical components in life support devices or systems.

© Atmel Corporation 2003. All rights reserved.

Atmel® and combinations thereof are the registered trademarks of Atmel Corporation or its subsidiaries.

Other terms and product names may be the trademarks of others.



Printed on recycled paper.

4728A-CLOCK-06/03

xM