



M27128A

Advanced 128K (16 x 8) UV Erasable PROM

Military

- **Fast Access Times:**
 - M27128A-20 200 ns
 - M27128A-30 300 ns
- **Low Power**
 - 140 mA Maximum Active
 - 50 mA Maximum Standby
- **Two Line Control**
- **Intelligent Programming™ Algorithm**
 - Fastest EPROM Programming
- **Intelligent Identifier™ Mode**
 - Automated Programming Operations
- **Compatible with M2764A and M27256**
- **Military Temperature Range**
 - 55°C to + 125°C (T_C)

The Intel M27128A is a 5V only, 131,072-bit ultraviolet erasable and electrically programmable read-only memory (EPROM). The M27128A is an advanced version of the M27128 and is fabricated with Intel's HMOSII-E technology which significantly reduces die size and greatly improves the device's performance, reliability and manufacturability.

Several advanced features have been designed into the M27128A that allow fast and reliable programming—the intelligent Programming™ Algorithm and the intelligent Identifier™ Mode. Programming equipment that takes advantage of these innovations will electronically identify the M27128A and then rapidly program it using an efficient programming method.

Two-line control and JEDEC-approved, 28 pin packaging are standard features of all Intel higher density EPROMs. This ensures easy microprocessor interfacing and minimum design efforts when upgrading, adding or choosing between non-volatile memory alternatives.

*HMOS is a patented process of intel Corporation

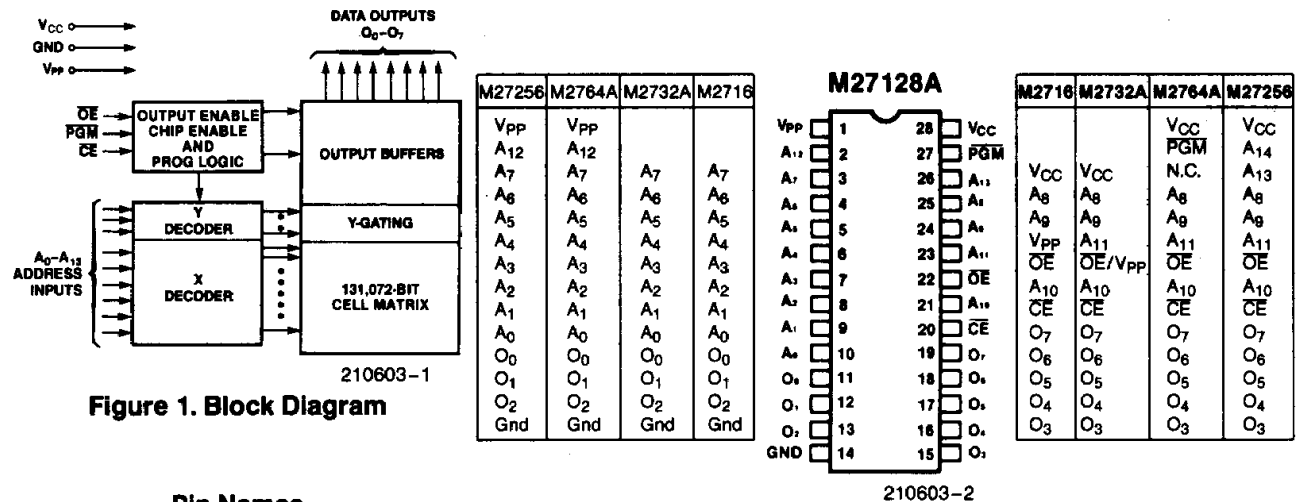
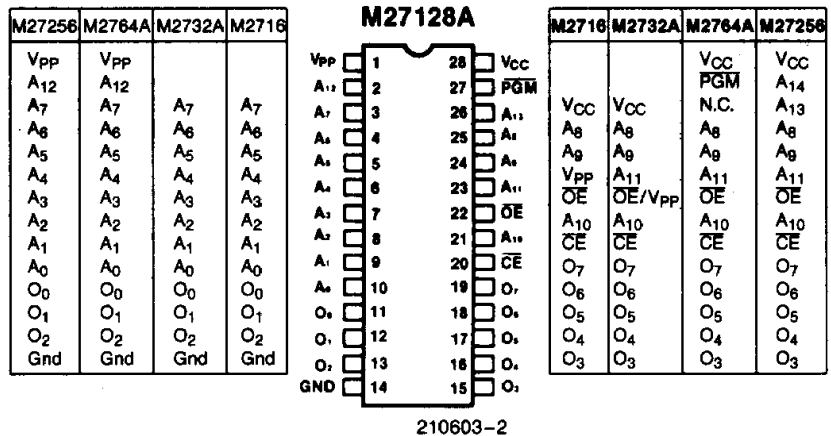

Figure 1. Block Diagram

| Pin Names | |
|---------------------------------|---------------|
| A ₀ -A ₁₃ | Addresses |
| CE | Chip Enable |
| OE | Output Enable |
| O ₀ -O ₇ | Outputs |
| PGM | Program |



NOTE:
Intel "Universal Site"-Compatible EPROM Pin Configurations are Shown in the Blocks Adjacent to the M27128A Pins

Figure 2. Pin Configurations

ABSOLUTE MAXIMUM RATINGS*

- Case Temperature Under Bias . . . -55°C to +125°C
- Storage Temperature -65°C to +150°C
- All Input or Output Voltages with Respect to Ground +6.25V to -0.6V
- Voltage on Pin 24 with Respect to Ground +13.5V to -0.6V
- V_{PP} Supply Voltage with Respect to Ground During Programming +14V to -0.6V

NOTICE: This is a production data sheet. The specifications are subject to change without notice.

**WARNING: Stressing the device beyond the "Absolute Maximum Ratings" may cause permanent damage. These are stress ratings only. Operation beyond the "Operating Conditions" is not recommended and extended exposure beyond the "Operating Conditions" may affect device reliability.*

Operating Conditions

| Symbol | Description | Min | Max | Units |
|-----------------|-------------------------------|------|------|-------|
| T _C | Case Temperature (Instant On) | -55 | +125 | °C |
| V _{CC} | Digital Supply Voltage | 4.50 | 5.50 | V |

READ OPERATION

D. C. CHARACTERISTICS (Over Specified Operating Conditions)

| Symbol | Parameter | Limits | | | | Comments |
|---------------------------------|---------------------------------|--------|--------------------|---------------------|------|-------------------------------|
| | | Min | Typ ⁽³⁾ | Max | Unit | |
| I _{LI} | Input Load Current | | | 10 | μA | V _{IN} = 5.5V |
| I _{LO} | Output Leakage Current | | | 10 | μA | V _{OUT} = 5.5V |
| I _{PP1} ⁽²⁾ | V _{PP} Current Read | | | 5 | mA | V _{PP} = 5.5V |
| I _{CC1} ⁽²⁾ | V _{CC} Current Standby | | | 50 | mA | CE = V _{IH} |
| I _{CC2} ⁽²⁾ | V _{CC} Current Active | | | 140 | mA | CE = OE = V _{IL} |
| V _{IL} | Input Low Voltage | -0.1 | | +0.8 | V | |
| V _{IH} | Input High Voltage | 2.0 | | V _{CC} + 1 | V | |
| V _{OL} | Output Low Voltage | | | 0.45 | V | I _{OL} = 2.1 mA |
| V _{OH} | Output High Voltage | 2.4 | | | V | I _{OH} = -400 μA |
| V _{PP} ⁽²⁾ | V _{PP} Read Voltage | 3.8 | | V _{CC} | V | V _{CC} = 5.0V ± 0.5V |

7

A.C. CHARACTERISTICS

| Symbol | Parameter | M27128A-20 | | M27128A-30 | | Unit | Comments |
|--------------------------------|--|------------|-----|------------|-----|------|---------------------------|
| | | Min | Max | Min | Max | | |
| t _{ACC} | Address to Output Delay | | 200 | | 300 | ns | CE = OE = V _{IL} |
| t _{CE} | CE to Output Delay | | 200 | | 300 | ns | OE = V _{IL} |
| t _{OE} | OE to Output Delay | | 85 | | 110 | ns | CE = V _{IL} |
| t _{DF} ⁽⁴⁾ | OE High to Output Float | 0 | 65 | 0 | 80 | ns | CE = V _{IL} |
| t _{OH} ⁽⁴⁾ | Output Hold from Addresses CE or OE Whichever Occurred First | 0 | | 0 | | ns | CE = OE = V _{IL} |

NOTES:

1. V_{CC} must be applied simultaneously or before V_{PP} and removed simultaneously or after V_{PP}.
2. V_{PP} may be connected directly to V_{CC} except during programming. The supply current would then be the sum of I_{CC} and I_{PP1}.
3. Typical values are for T_C = 25°C and nominal supply voltages.
4. Output Float is defined as the point where data is no longer driven—see timing diagram on the following page.

CAPACITANCE $T_C = 25^\circ\text{C}$, $f = 1\text{ MHz}$

| Symbol | Parameter | Typ(1) | Max | Units | Conditions |
|-----------|--------------------|--------|-----|-------|----------------|
| C_{IN} | Input Capacitance | 4 | 6 | pF | $V_{IN} = 0V$ |
| C_{OUT} | Output Capacitance | 8 | 12 | pF | $V_{OUT} = 0V$ |

A.C. TESTING INPUT, OUTPUT WAVEFORM

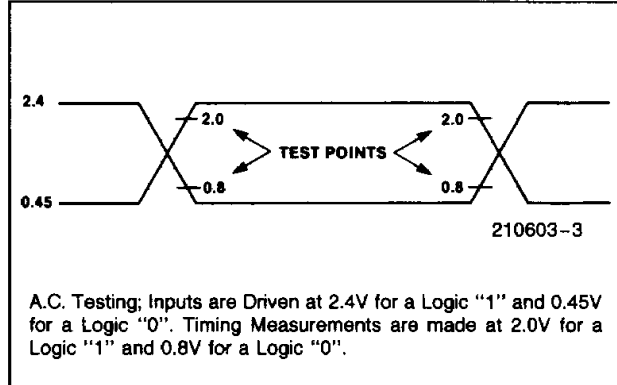

A.C. TESTING LOAD CIRCUIT

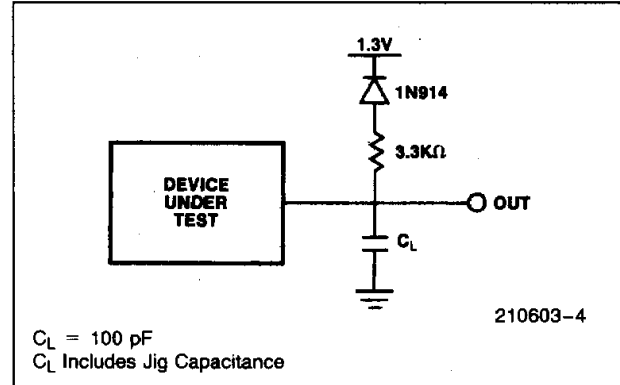

A.C. WAVEFORMS

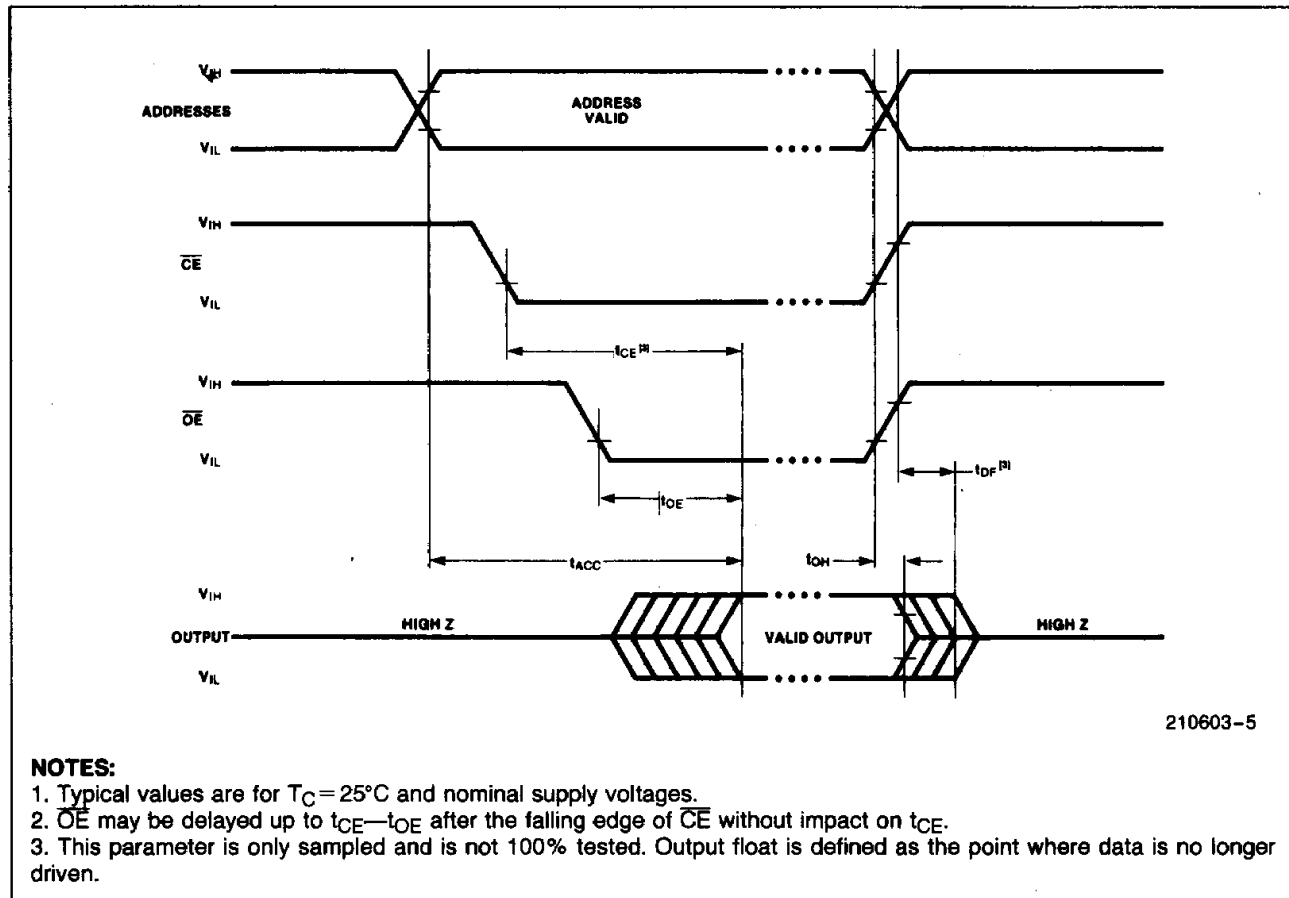

DEVICE OPERATION

The seven modes of operation of the M27128A are listed in Table 1. A single 5V power supply is required in the read mode. All inputs are TTL levels except for V_{PP} and 12V on A9 for intelligent identifier mode.

Table 1. Mode Selection

| Mode | Pins | \overline{CE} (20) | \overline{OE} (22) | PGM (27) | A ₉ (24) | V _{PP} (1) | V _{CC} (28) | Outputs (11-13, 15-19) |
|-------------------------|------|----------------------|----------------------|-----------------|---------------------|---------------------|----------------------|------------------------|
| Read | | V _{IL} | V _{IL} | V _{IH} | X | V _{CC} | V _{CC} | D _{OUT} |
| Output Disable | | V _{IL} | V _{IH} | V _{IH} | X | V _{CC} | V _{CC} | High Z |
| Standby | | V _{IH} | X | X | X | V _{CC} | V _{CC} | High Z |
| Verify | | V _{IL} | V _{IL} | V _{IH} | X | V _{PP} | V _{CC} | D _{OUT} |
| Program Inhibit | | V _{IH} | X | X | X | V _{PP} | V _{CC} | High Z |
| Intelligent Identifier | | V _{IL} | V _{IL} | V _{IH} | V _H | V _{CC} | V _{CC} | Code |
| Intelligent Programming | | V _{IL} | V _{IH} | V _{IL} | X | V _{PP} | V _{CC} | D _{IN} |

NOTES:

1. X can be V_{IH} or V_{IL}.
2. V_H = 12.0V ± 0.5V.

Read Mode

The M27128A has two control functions, both of which must be logically active in order to obtain data at the outputs. Chip Enable (\overline{CE}) is the power control and should be used for device selection. Output Enable (\overline{OE}) is the output control and should be used to gate data from the output pins, independent of device selection. Assuming that addresses are stable, the address access time (t_{ACC}) is equal to the delay from \overline{CE} to output (t_{CE}). Data is available at the outputs after a delay of t_{OE} from the falling edge of \overline{OE} , assuming that \overline{CE} has been low and addresses have been stable for at least $t_{ACC}-t_{OE}$.

Standby Mode

The M27128A has standby mode which reduces the maximum current from 100 mA to 40 mA. The M27128A is placed in the standby mode by applying a TTL-high signal to the \overline{CE} input. When in standby mode, the outputs are in a high impedance state, independent of the \overline{OE} input.

Output OR-Tieing

Because EPROMs are usually used in larger memory arrays, Intel has provided 2 control lines which accommodate this multiple memory connection. The two control lines allow for:

- a) the lowest possible memory power dissipation, and
- b) complete assurance that output bus contention will not occur

To use these two control lines most efficiently, \overline{CE} (pin 20) should be decoded and used as the primary device selecting function, while \overline{OE} (pin 22) should be made a common connection to all devices in the array and connected to the \overline{READ} line from the system control bus. This assures that all deselected memory devices are in their low power standby mode and that the output pins are active only when data is desired from a particular memory device.

System Considerations

The power switching characteristics of HMOSII-E EPROMs require careful decoupling of the devices. The supply current, I_{CC} , has three segments that are of interest to the system designer—the standby current level, the active current level, and the transient current peaks that are produced by the falling and rising edges of Chip Enable. The magnitude of these transient current peaks is dependent on the output capacitive loading of the device. The associated transient voltage peaks can be suppressed by complying with Intel's Two-Line Control, as detailed in Intel's Application Note AP-72, Order Number 8566, and by properly selected decoupling capacitors. It is recommended that a 0.1 μ F ceramic capacitor be used on every device between V_{CC} and GND. This should be a high frequency capacitor for low inherent inductance and should be placed as close to the device as possible. In addition, a 4.7 μ F bulk electrolytic capacitor should be used between V_{CC} and GND for every eight devices. The bulk capacitor should be located near where the power supply is connected to the array. The purpose of the bulk capacitor is to overcome the voltage droop caused by the inductive effect of PC board-traces. This inductive effect should be further minimized through special layout considerations such as larger traces and gridding (refer to High Speed Memory System Design Using 2147H, AP-74). In particular, the V_{SS} (Ground) plane should be as stable as possible.

7

Programming Modes

Caution: Exceeding 14V on pin 1 (V_{PP}) will permanently damage the M27128A.

Initially, and after each erasure, all bits of the M27128A are in the "1" state. Data is introduced by selectively programming "0s" into the desired bit locations. Although only "0s" will be programmed, both "1s" and "0s" can be present in the data word. The only way to change a "0" to a "1" is by ultraviolet light erasure.

The M27128A is in the programming mode when V_{PP} input is at 12.5V and \overline{CE} and PGM are both at TTL low. The data to be programmed is applied

8 bits in parallel to the data output pins. The levels required for the address and data inputs are TTL.

Intelligent Programming™ Algorithm

The M27128A intelligent Programming Algorithm rapidly programs Intel M27128A EPROMs using an efficient and reliable method particularly suited to the production programming environment. Typical programming time for individual devices is less than one and a half minutes. Programming reliability is also ensured as the incremental program margin of each byte is continually monitored to determine when it has been successfully programmed. A flow-chart of the M27128A intelligent Programming Algorithm is shown in Figure 3.

The intelligent Programming Algorithm utilizes two different pulse types: initial and overprogram. The duration of the initial \overline{CE} pulse(s) is one millisecond, which will then be followed by a longer overprogram pulse of length $3X$ ms. X is an iteration counter and is equal to the number of the initial one millisecond pulses applied to a particular M27128A location, before a correct verify occurs. Up to 25 one-millisecond pulses per byte are provided for before the overprogram pulse is applied.

The entire sequence of program pulses and byte verifications is performed at $V_{CC} = 6.0V$ and $V_{PP} = 12.5V$. When the intelligent Programming cycle has been completed, all bytes should be compared to the original data with $V_{CC} = V_{PP} = 5.0V$.

Program Inhibit

Programming of multiple M27128As in parallel with different data is easily accomplished by using the Program Inhibit mode. A high-level \overline{CE} or \overline{PGM} input inhibits the other M27128As from being programmed.

Except for \overline{CE} , all like inputs (including \overline{OE}) of the parallel M27128As may be common. A TTL low-level pulse applied to the \overline{CE} input with V_{PP} at 12.5V will program the selected M27128A.

Table 2. M27128A Intelligent Identifier™ Bytes

| Identifier | Pins | A ₀ (10) | O ₇ (19) | O ₆ (18) | O ₅ (17) | O ₄ (16) | O ₃ (15) | O ₂ (13) | O ₁ (12) | O ₀ (11) | Hex Data |
|-------------------|------|------------------------|------------------------|------------------------|------------------------|------------------------|------------------------|------------------------|------------------------|------------------------|----------|
| Manufacturer Code | | V _{IL} | 1 | 0 | 0 | 0 | 1 | 0 | 0 | 1 | 89 |
| Device Code | | V _{IH} | 1 | 0 | 0 | 0 | 1 | 0 | 0 | 1 | 89 |

NOTES:

1. A₉ = 12.0V ± 0.5V.
2. A₁ - A₈, A₁₀ - A₁₃, \overline{CE} , \overline{OE} = V_{IL}.

Verify

A verify should be performed on the programmed bits to determine that they have been correctly programmed. The verify is performed with \overline{OE} at V_{IL}, \overline{CE} at V_{IL}, \overline{PGM} at V_{IH} and V_{PP} at 12.5V.

Intelligent Identifier™ Mode

The intelligent Identifier Mode allows the reading out of a binary code from an EPROM that will identify its manufacturer and type. This mode is intended for use by programming equipment for the purpose of automatically matching the device to be programmed with its corresponding programming algorithm. This mode is functional in the 25°C ± 5°C ambient temperature range that is required when programming the M27128A.

To activate this mode, the programming equipment must force 11.5V to 12.5V on address line A₉ (pin 24) of the M27128A. Two identifier bytes may then be sequenced from the device outputs by toggling address line A₀ (pin 10) from V_{IL} to V_{IH}. All other address lines must be held at V_{IL} during the intelligent Identifier Mode.

Byte 0 (A₀=V_{IL}) represents the manufacturer code and byte 1 (A₀=V_{IH}) the device identifier code. For the Intel M27128A, these two identifier bytes are given in Table 2. All identifiers for manufacturer and device codes will possess odd parity, with the MSB (O₇) defined as the parity bit.

ERASURE CHARACTERISTICS

The erasure characteristics of the M27128A are such that erasure begins to occur upon exposure to light with wavelengths shorter than approximately 4000 Angstroms (Å). It should be noted that sunlight and certain types of fluorescent lamps have wavelengths in the 3000-4000Å range. Data show that constant exposure to room level fluorescent lighting could erase that typical M27128A in approximately 3 years, while it would take approximately 1 week

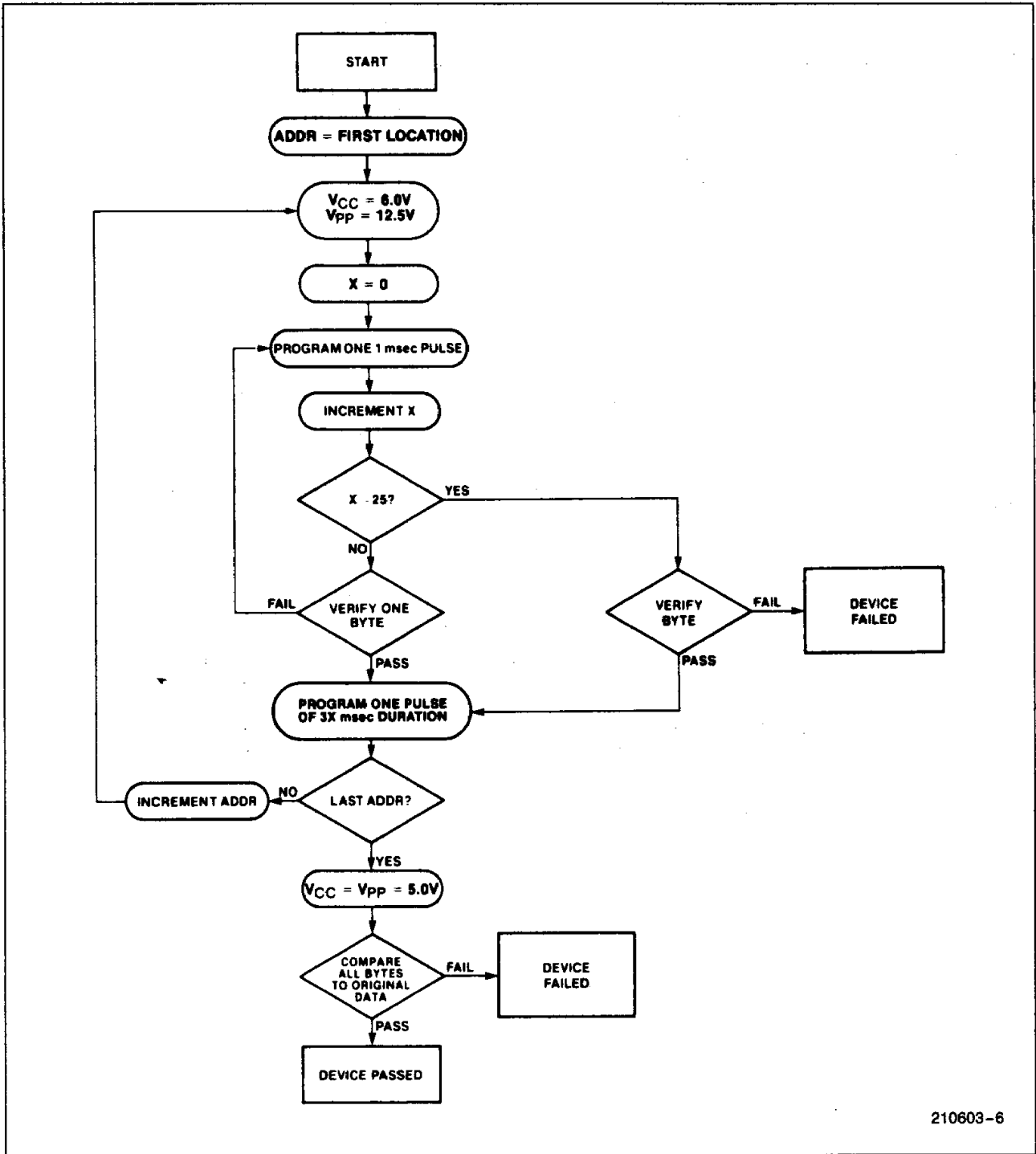

210603-6

Figure 3. M27128A Intelligent Programming™ Flowchart

to cause erasure when exposed to direct sunlight. If the M27128A is to be exposed to these types of lighting conditions for extended periods of time, opaque labels should be placed over the M27128A window to prevent unintentional erasure.

The recommended erasure procedure for the M27128A is exposure to shortwave ultraviolet light which has a wavelength of 2537 Angstroms (Å). The integrated dose (i.e., UV intensity × exposure time) for erasure should be a minimum of 15 Wsec/cm².

The erasure time with this dosage is approximately 15 to 20 minutes using an ultraviolet lamp with a 12000 μW/cm² power rating. The M27128A should be placed within 1 inch of the lamp tubes during erasure. The maximum integrated dose a M27128A can be exposed to without damage is 7258 Wsec/cm² (1 week @ 12000 μW/cm²). Exposure of the M27128A to high intensity UV light for longer periods may cause permanent damage.

intelligent Programming™ Algorithm

D.C. PROGRAMMING CHARACTERISTICS (Over Specified Operating Conditions)

| Symbol | Parameter | Limits | | | Comments (Note 1) |
|------------------|---|--------|-----------------|------|--|
| | | Min | Max | Unit | |
| I _{LI} | Input Current (All Inputs) | | 10 | μA | V _{IN} = V _{IL} or V _{IH} |
| V _{IL} | Input Low Level (All Inputs) | -0.1 | 0.8 | V | |
| V _{IH} | Input High Level | 2.0 | V _{CC} | V | |
| V _{OL} | Output Low Voltage During Verify | | 0.45 | V | I _{OL} = 2.1 mA |
| V _{OH} | Output High Voltage During Verify | 2.4 | | V | I _{OH} = -400 μA |
| I _{CC2} | V _{CC} Supply Current (Program & Verify) | | 100 | mA | |
| I _{PP2} | V _{PP} Supply Current (Program) | | 50 | mA | $\overline{CE} = V_{IL}$ |
| V _H | A _g intelligent Identifier Voltage | 11.5 | 12.5 | V | |

NOTE:

- V_{CC} must be applied simultaneously or before V_{PP} and removed simultaneously or after V_{PP}.

A.C. PROGRAMMING CHARACTERISTICS (Over Specified Operating Conditions)

| Symbol | Parameter | Limits | | | | Comments* (Note 1) |
|---------------------------------|--|--------|-----|-------|------|-----------------------|
| | | Min | Typ | Max | Unit | |
| t _{AS} | Address Setup Time | 2 | | | μs | |
| t _{OES} | \overline{OE} Setup Time | 2 | | | μs | |
| t _{DS} | Data Setup Time | 2 | | | μs | |
| t _{AH} | Address Hold Time | 0 | | | μs | |
| t _{DH} | Data Hold Time | 2 | | | μs | |
| t _{DFP} ⁽⁴⁾ | \overline{OE} High to Output Float Delay | 0 | | 130 | ns | |
| t _{VPS} | V _{PP} Setup Time | 2 | | | μs | |
| t _{VCS} | V _{CC} Setup Time | 2 | | | μs | |
| t _{CES} | \overline{CE} Setup Time | 2 | | | μs | |
| t _{PW} | \overline{PGM} Initial Program Pulse Width | 0.95 | 1.0 | 1.05 | ms | (Note 3) |
| t _{OPW} | \overline{PGM} Overprogram Pulse Width | 2.85 | | 78.75 | ms | (Note 2) |
| t _{OE} | Data Valid from \overline{OE} | | | 150 | ns | |

NOTES:

1. V_{CC} must be applied simultaneously or before V_{PP} and removed simultaneously or after V_{PP}.
2. The length of the overprogram pulse may vary from 2.85 ms to 78.75 ms as a function of the iteration counter value X.
3. Initial Program Pulse width tolerance is 1 ms ± 5%.
4. Output Float is defined as the point where data is no longer driven—see timing diagram.

***A.C. CONDITIONS OF TEST**

Input Rise and Fall Times (10% to 90%) 20 ns
 Input Pulse Levels 0.45V to 2.4V
 Input Timing Reference Level 0.8V and 2.0V
 Output Timing Reference Level 0.8V and 2.0V

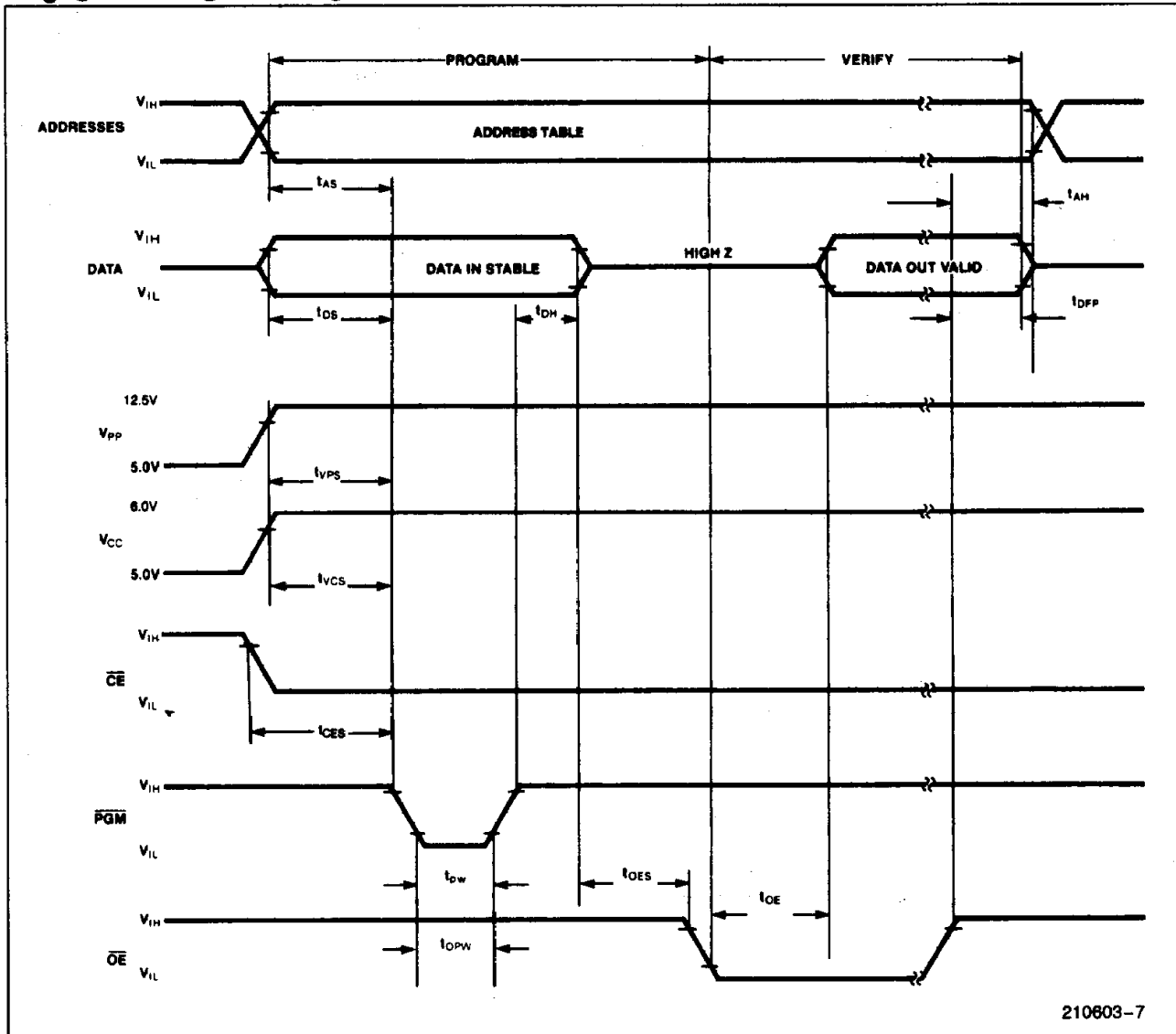
intelligent Programming™ WAVEFORMS

210603-7

NOTES:

1. The Input Timing Reference Level is 0.8V for V_{IL} and 2V for a V_{IH} .
2. t_{OE} and t_{DFF} are characteristics of the device but must be accommodated by the programmer.
3. When programming the M27128A, a 0.1 μF capacitor is required across V_{PP} and ground to suppress spurious voltage transients which can damage the device.