

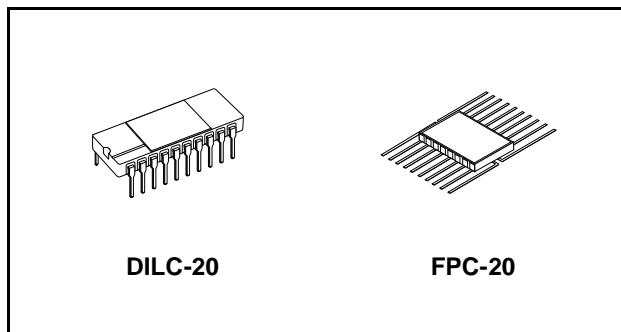

# M54HCT245

## RAD HARD OCTAL BUS TRANSCEIVER WITH 3 STATE OUTPUTS (NON INVERTED)

- HIGH SPEED:  
 $t_{PD} = 13\text{ns}$  (TYP.) at  $V_{CC} = 4.5\text{V}$
- LOW POWER DISSIPATION:  
 $I_{CC} = 4\mu\text{A}$ (MAX.) at  $T_A=25^\circ\text{C}$
- COMPATIBLE WITH TTL OUTPUTS:  
 $V_{IH} = 2\text{V}$  (MIN.)  $V_{IL} = 0.8\text{V}$  (MAX)
- SYMMETRICAL OUTPUT IMPEDANCE:  
 $|I_{OH}| = |I_{OL}| = 6\text{mA}$  (MIN)
- BALANCED PROPAGATION DELAYS:  
 $t_{PLH} \cong t_{PHL}$
- PIN AND FUNCTION COMPATIBLE WITH 54 SERIES 245
- SPACE GRADE-1: ESA SCC QUALIFIED
- 50 krad QUALIFIED, 100 krad AVAILABLE ON REQUEST
- NO SEL UNDER HIGH LET HEAVY IONS IRRADIATION
- DEVICE FULLY COMPLIANT WITH SCC-9405-014



### ORDER CODES

PACKAGE	FM	EM
DILC	M54HCT245D	M54HCT245D1
FPC	M54HCT245K	M54HCT245K1

### DESCRIPTION

The M54HCT245 is an advanced high-speed CMOS OCTAL BUS TRANSCEIVER (3-STATE) fabricated with silicon gate C<sup>2</sup>MOS technology. This IC is intended for two-way asynchronous communication between data buses, and the

direction of data transmission is determined by DIR input. The enable input  $\bar{G}$  can be used to disable the device so that the buses are effectively isolated.

All inputs are equipped with protection circuits against static discharge and transient excess voltage.

All floating bus terminals during High Z State must be held HIGH or LOW.

### PIN CONNECTION

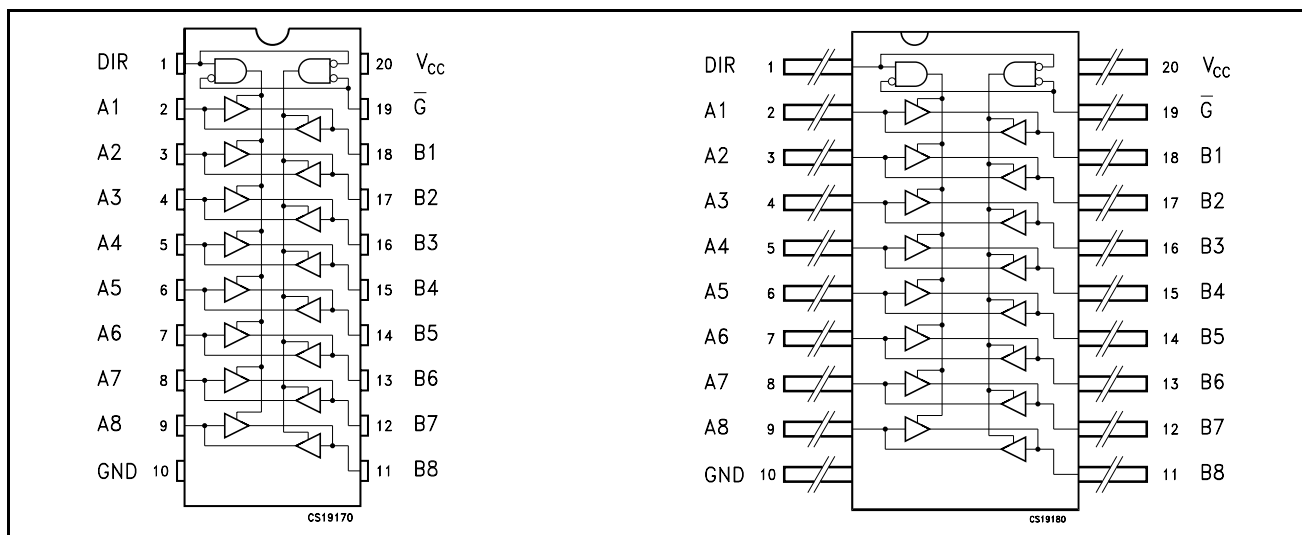

Figure 1: IEC Logic Symbols

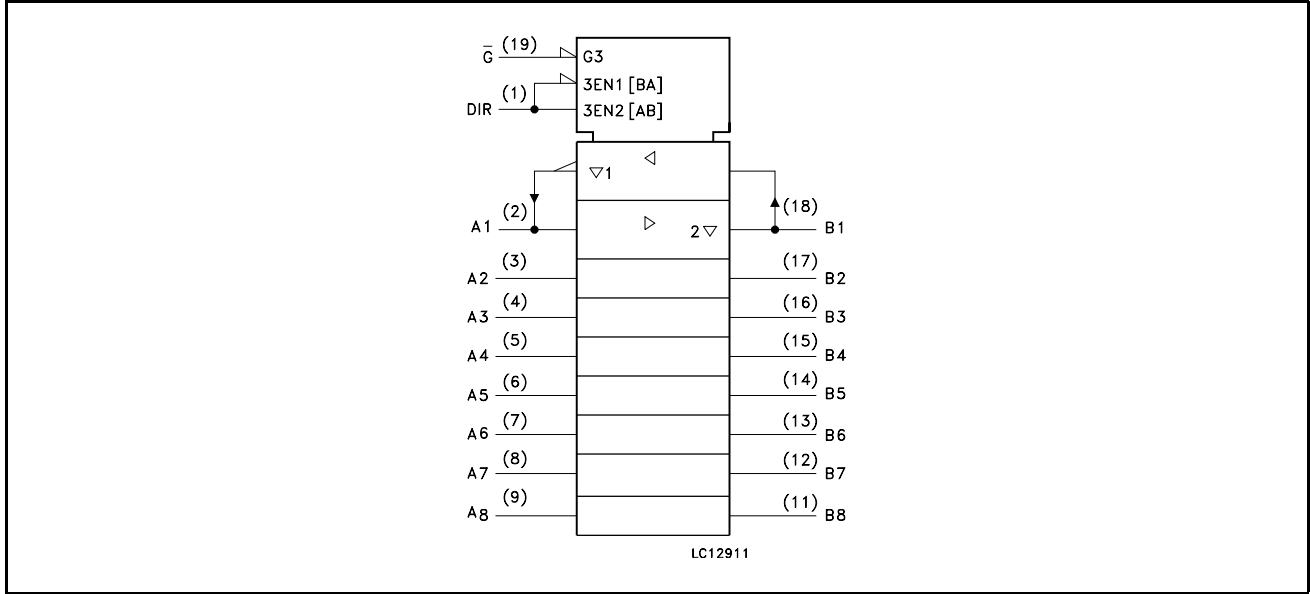

Figure 2: Input And Output Equivalent Circuit

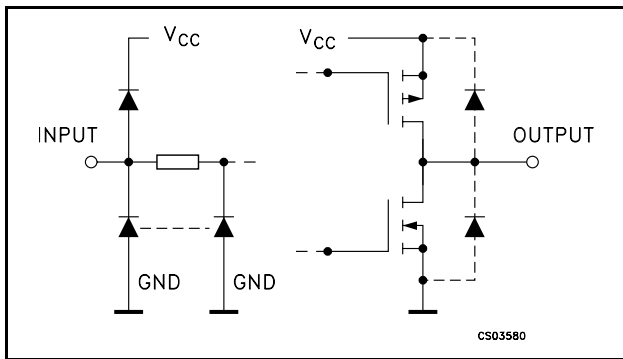

Table 1: Pin Description

PIN N°	SYMBOL	NAME AND FUNCTION
1	DIR	Directional Control
2, 3, 4, 5, 6, 7, 8, 9	A1 to A8	Data Inputs/Outputs
18, 17, 16, 15, 14, 13, 12, 11	B1 to B8	Data Inputs/Outputs
19	G	Output Enable Input
10	GND	Ground (0V)
20	V <sub>CC</sub>	Positive Supply Voltage

Table 2: Truth Table

INPUTS		FUNCTION		OUTPUT
$\bar{G}$	DIR	A BUS	B BUS	Yn
L	L	OUTPUT	INPUT	A = B
L	H	INPUT	OUTPUT	B = A
H	X	Z	Z	Z

X : Don't Care  
Z : High Impedance

**Table 3: Absolute Maximum Ratings**

Symbol	Parameter	Value	Unit
$V_{CC}$	Supply Voltage	-0.5 to +7	V
$V_I$	DC Input Voltage	-0.5 to $V_{CC} + 0.5$	V
$V_O$	DC Output Voltage	-0.5 to $V_{CC} + 0.5$	V
$I_{IK}$	DC Input Diode Current	$\pm 20$	mA
$I_{OK}$	DC Output Diode Current	$\pm 20$	mA
$I_O$	DC Output Current	$\pm 35$	mA
$I_{CC}$ or $I_{GND}$	DC $V_{CC}$ or Ground Current	$\pm 70$	mA
$P_D$	Power Dissipation	420	mW
$T_{stg}$	Storage Temperature	-65 to +150	°C
$T_L$	Lead Temperature (10 sec)	265	°C

Absolute Maximum Ratings are those values beyond which damage to the device may occur. Functional operation under these conditions is not implied

**Table 4: Recommended Operating Conditions**

Symbol	Parameter	Value	Unit
$V_{CC}$	Supply Voltage	4.5 to 5.5	V
$V_I$	Input Voltage	0 to $V_{CC}$	V
$V_O$	Output Voltage	0 to $V_{CC}$	V
$T_{op}$	Operating Temperature	-55 to 125	°C
$t_r, t_f$	Input Rise and Fall Time ( $V_{CC} = 4.5$ to $5.5V$ )	0 to 500	ns

Table 5: DC Specifications

Symbol	Parameter	Test Condition		Value						Unit	
		V <sub>CC</sub> (V)		T <sub>A</sub> = 25°C			-40 to 85°C		-55 to 125°C		
				Min.	Typ.	Max.	Min.	Max.	Min.		Max.
V <sub>IH</sub>	High Level Input Voltage	4.5 to 5.5		2.0			2.0		2.0		V
V <sub>IL</sub>	Low Level Input Voltage	4.5 to 5.5				0.8		0.8		0.8	V
V <sub>OH</sub>	High Level Output Voltage	4.5	I <sub>O</sub> = -20 μA	4.4	4.5		4.4		4.4		V
			I <sub>O</sub> = -6.0 mA	4.18	4.31		4.13		4.10		
V <sub>OL</sub>	Low Level Output Voltage	4.5	I <sub>O</sub> = 20 μA		0.0	0.1		0.1		0.1	V
			I <sub>O</sub> = 6.0 mA		0.17	0.26		0.33		0.40	
I <sub>I</sub>	Input Leakage Current	5.5	V <sub>I</sub> = V <sub>CC</sub> or GND			± 0.1		± 1		± 1	μA
I <sub>OZ</sub>	High Impedance Output Leakage Current	5.5	V <sub>I</sub> = V <sub>IH</sub> or V <sub>IL</sub> V <sub>O</sub> = V <sub>CC</sub> or GND			± 0.5		± 5		± 10	μA
I <sub>CC</sub>	Quiescent Supply Current	5.5	V <sub>I</sub> = V <sub>CC</sub> or GND			4		40		80	μA
Δ I <sub>CC</sub>	Additional Worst Case Supply Current	5.5	Per Input pin V <sub>I</sub> = 0.5V or V <sub>I</sub> = 2.4V Other Inputs at V <sub>CC</sub> or GND I <sub>O</sub> = 0			2.0		2.9		3.0	mA

Table 6: AC Electrical Characteristics (C<sub>L</sub> = 50 pF, Input t<sub>r</sub> = t<sub>f</sub> = 6ns)

Symbol	Parameter	Test Condition			Value						Unit	
		V <sub>CC</sub> (V)	C <sub>L</sub> (pF)		T <sub>A</sub> = 25°C			-40 to 85°C		-55 to 125°C		
					Min.	Typ.	Max.	Min.	Max.	Min.		Max.
t <sub>TLH</sub> t <sub>THL</sub>	Output Transition Time	4.5	50			7	12		15		18	ns
t <sub>PLH</sub> t <sub>PHL</sub>	Propagation Delay Time	4.5	50			13	22		28		33	ns
			150			18	30		38		45	
t <sub>PZL</sub> t <sub>PZH</sub>	High Impedance Output Enable Time	4.5	50	R <sub>L</sub> = 1 KΩ		19	30		38		45	ns
			150	R <sub>L</sub> = 1 KΩ		24	38		48		57	
t <sub>PLZ</sub> t <sub>PHZ</sub>	High Impedance Output Disable Time	4.5	50	R <sub>L</sub> = 1 KΩ		17	30		38		45	ns

Table 7: Capacitive Characteristics

Symbol	Parameter	Test Condition			Value						Unit	
		V <sub>CC</sub> (V)		DIR, $\bar{G}$	T <sub>A</sub> = 25°C			-40 to 85°C		-55 to 125°C		
					Min.	Typ.	Max.	Min.	Max.	Min.		Max.
C <sub>IN</sub>	Input Capacitance			DIR, $\bar{G}$		5	10		10		10	pF
C <sub>I/OUT</sub>	Output Capacitance			An, Bn		13						pF
C <sub>PD</sub>	Power Dissipation Capacitance (note 1)					41						pF

1) C<sub>PD</sub> is defined as the value of the IC's internal equivalent capacitance which is calculated from the operating current consumption without load. (Refer to Test Circuit). Average operating current can be obtained by the following equation.  $I_{CC(opr)} = C_{PD} \times V_{CC} \times f_{IN} + I_{CC}/8$  (per circuit)

Figure 3: Test Circuit

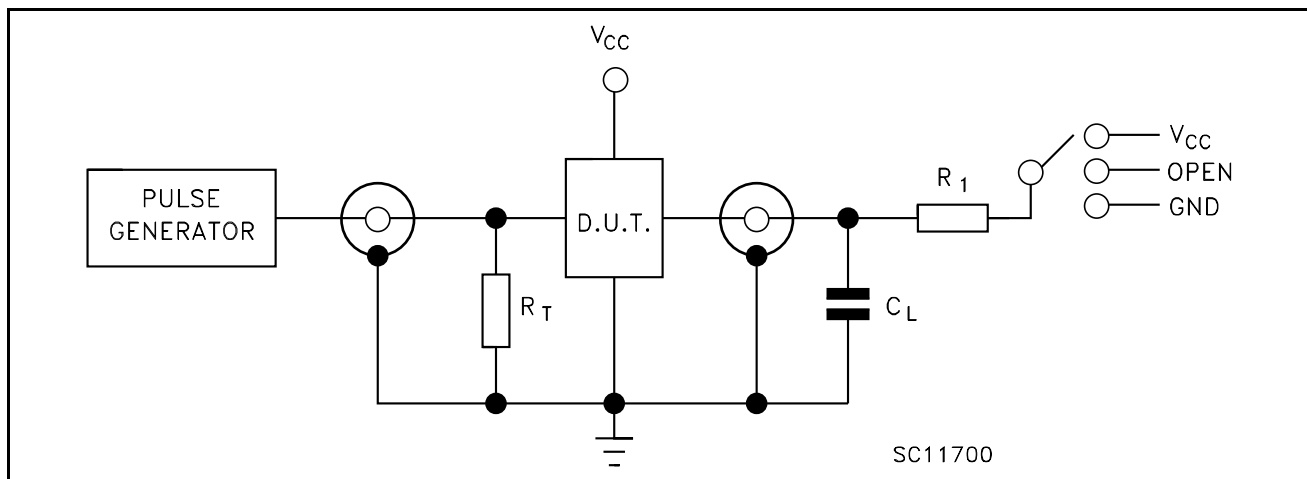

TEST	SWITCH
t <sub>PLH</sub> , t <sub>PHL</sub>	Open
t <sub>PZL</sub> , t <sub>PLZ</sub>	V <sub>CC</sub>
t <sub>PZH</sub> , t <sub>PHZ</sub>	GND

C<sub>L</sub> = 50pF/150pF or equivalent (includes jig and probe capacitance)

R<sub>1</sub> = 1KΩ or equivalent

R<sub>T</sub> = Z<sub>OUT</sub> of pulse generator (typically 50Ω)

Figure 4: Waveform - Propagation Delay Time (f=1MHz; 50% duty cycle)

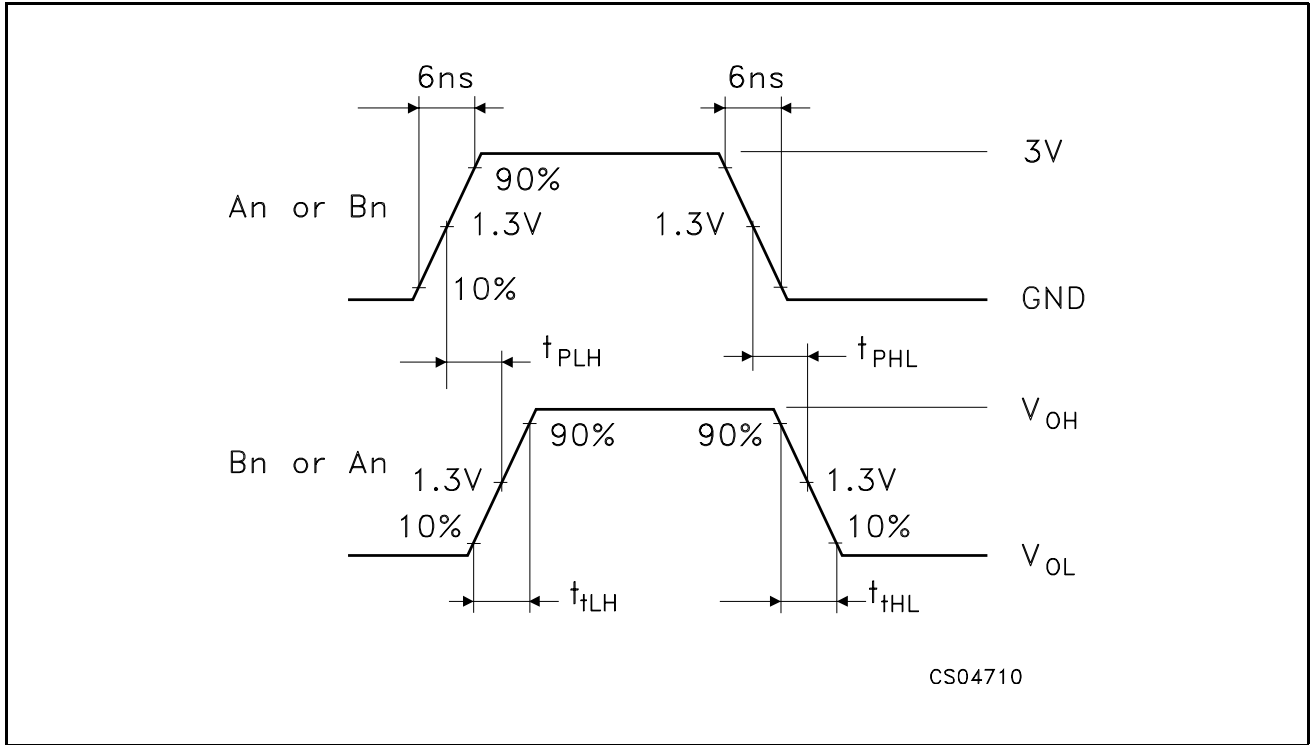
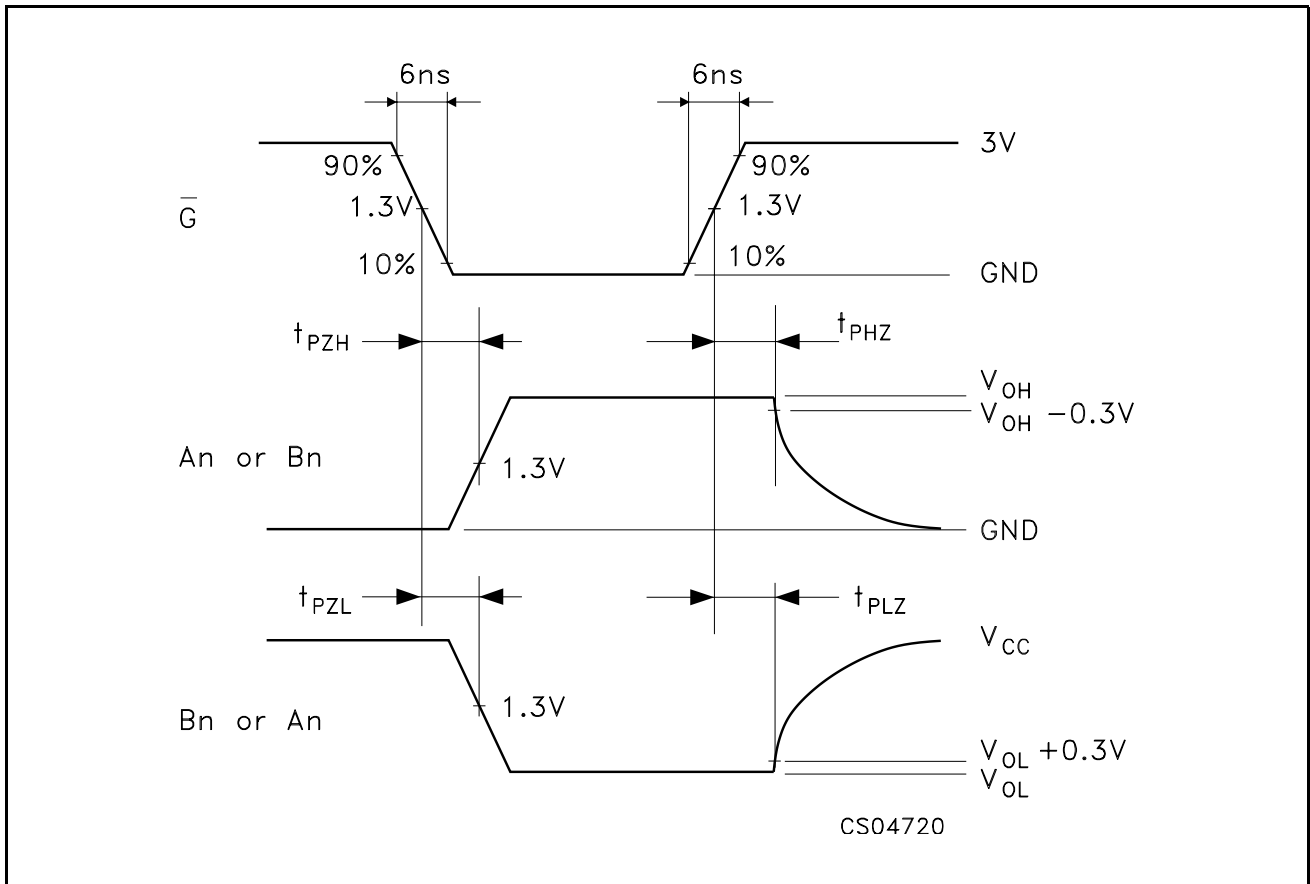
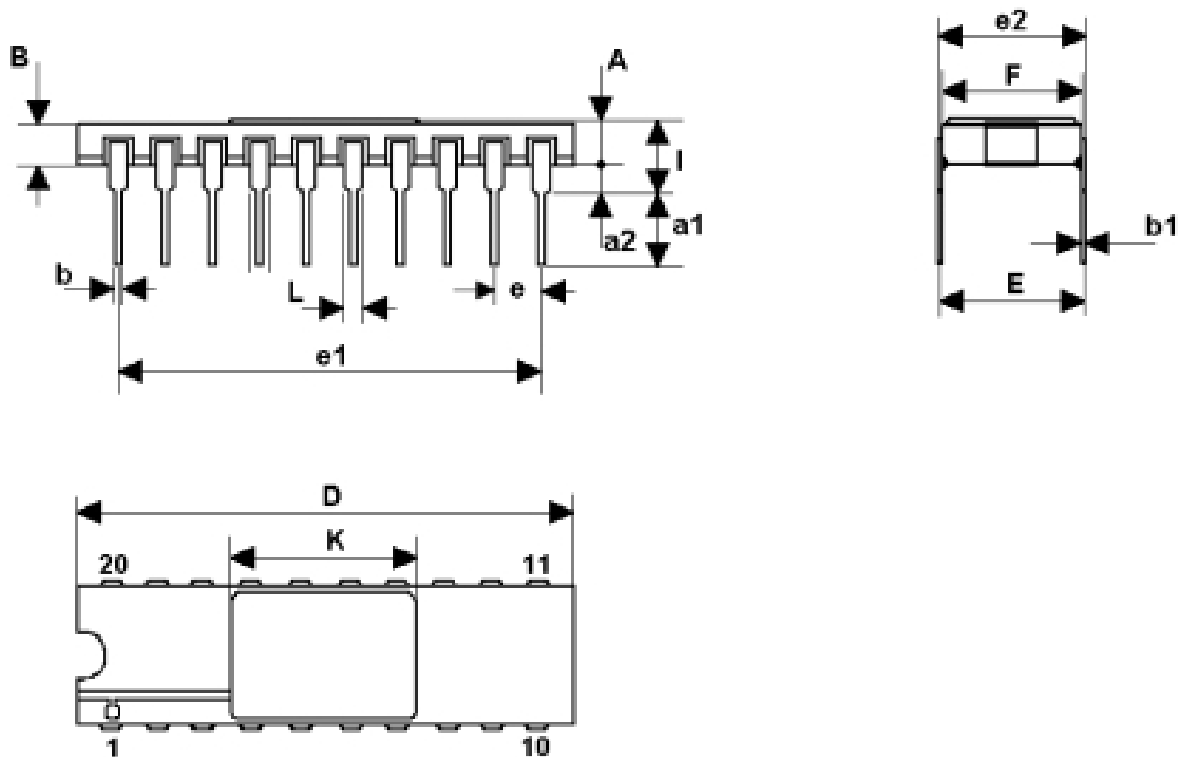

Figure 5: Waveform - Output Enable And Disable Time (f=1MHz; 50% duty cycle)



## DILC-20 MECHANICAL DATA

DIM.	mm.			inch		
	MIN.	TYP	MAX.	MIN.	TYP.	MAX.
A	2.1		2.71	0.083		0.107
a1	3.00		3.70	0.118		0.146
a2	0.63	0.88	1.14	0.025	0.035	0.045
B	1.93	2.03	2.23	0.076	0.080	0.088
b	0.40	0.45	0.50	0.016	0.018	0.020
b1	0.20	0.254	0.30	0.008	0.010	0.012
D	25.14	25.40	25.65	0.990	1.000	1.010
E	7.36	7.62	7.87	0.290	0.300	0.310
e		2.54			0.100	
e1	22.73	22.86	22.99	0.895	0.900	0.905
e2	7.62	7.87	8.12	0.300	0.310	0.320
F	7.29	7.49	7.70	0.287	0.295	0.303
l			3.86			0.152
K	11.30		11.56	0.445		0.455
L	1.14	1.27	1.40	0.045	0.050	0.055



0016178J

**FPC-20 MECHANICAL DATA**

DIM.	mm.			inch		
	MIN.	TYP	MAX.	MIN.	TYP.	MAX.
A	9.98	10.16	10.34	0.393	0.400	0.407
B	9.98	10.16	10.34	0.393	0.400	0.407
C	1.45	1.61	1.78	0.57	0.63	0.070
D	0.10	0.127	0.18	0.004	0.005	0.007
E	11.30	11.43	11.56	0.445	0.450	0.455
F		1.27			0.050	
G	0.38	0.43	0.48	0.015	0.017	0.019
H	7.24		8.16	0.285		0.320
L	24.46		26.67	0.960		1.050
M	0.45	0.50	0.55	0.018	0.020	0.022
N		7.87			0.310	
O	1.14	1.27	1.40	0.045	0.050	0.055
P	0.10	0.18	0.25	0.004	0.007	0.010

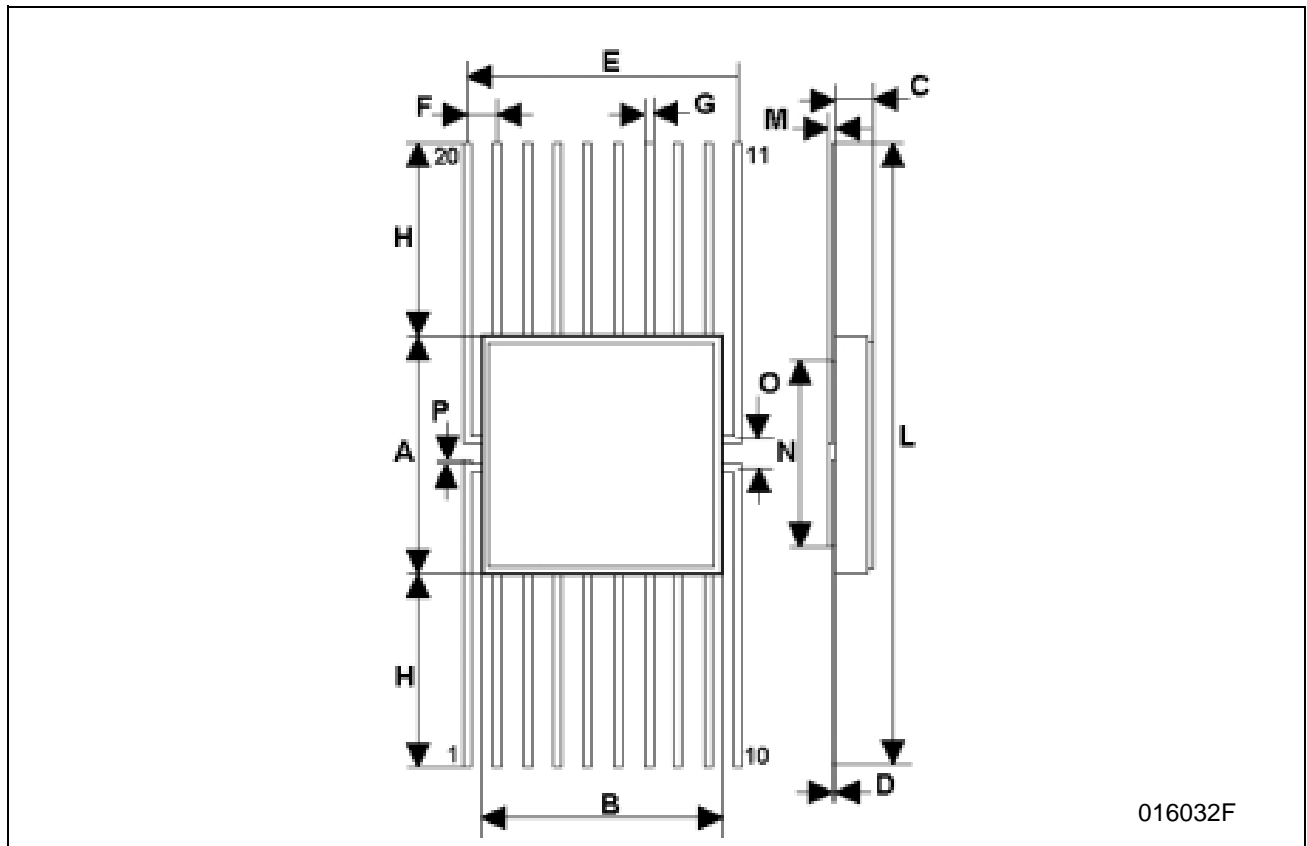



**Table 8: Revision History**

Date	Revision	Description of Changes
15-Jun-2004	1	First Release

Information furnished is believed to be accurate and reliable. However, STMicroelectronics assumes no responsibility for the consequences of use of such information nor for any infringement of patents or other rights of third parties which may result from its use. No license is granted by implication or otherwise under any patent or patent rights of STMicroelectronics. Specifications mentioned in this publication are subject to change without notice. This publication supersedes and replaces all information previously supplied. STMicroelectronics products are not authorized for use as critical components in life support devices or systems without express written approval of STMicroelectronics.

The ST logo is a registered trademark of STMicroelectronics  
All other names are the property of their respective owners

© 2004 STMicroelectronics - All Rights Reserved  
STMicroelectronics GROUP OF COMPANIES

Australia - Belgium - Brazil - Canada - China - Czech Republic - Finland - France - Germany - Hong Kong - India - Israel - Italy - Japan -  
Malaysia - Malta - Morocco - Singapore - Spain - Sweden - Switzerland - United Kingdom - United States.  
<http://www.st.com>