

Rad-hard precision quad operational amplifier

Features

- High radiation immunity: 300 kRad TID at high dose rate
- ELDRS-free up to 100 krad
- 300 krad low dose rate on-going
- SEL immune at LET = 120 MeV.cm²/mg at 125°C
- SET characterized
- Hermetic package
- Rail-to-rail input/output
- 8 MHz gain bandwidth product
- Low input offset voltage: 60 μV typ
- Supply current: 2.2 mA typ per amplifier
- Operating from 4 to 14 V
- Input bias current: 6 nA typ
- QLM-V qualified under smd 5962-08222

Applications

- Space probes and satellites
- Harsh environment

Description

The RHF484 is a rail-to-rail precision bipolar quad operational amplifier featuring a low input offset voltage and a wide supply voltage.

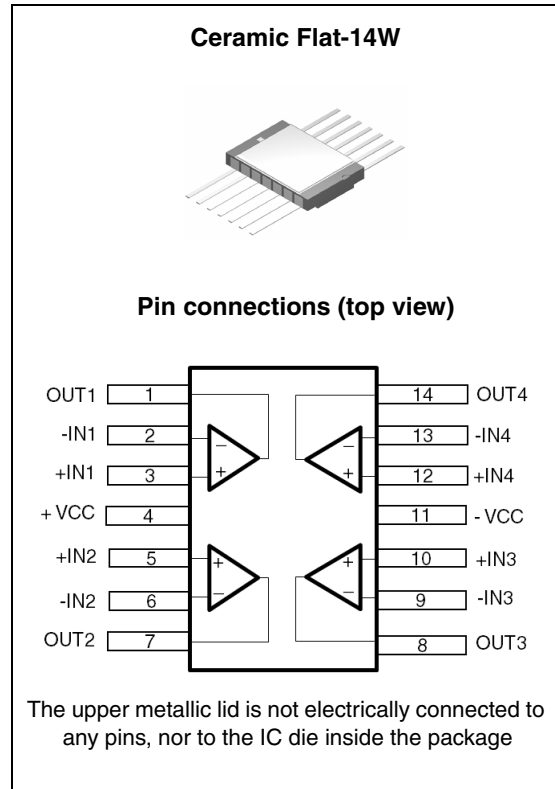

Designed to increase tolerance to radiation, the RHF484 is housed in a hermetic 14-pin flat package, making it an ideal product for space applications and harsh environments.

Table 1. Device summary

Reference	SMD pin	Quality level	Temp range	Package	Lead finish	Mass	EPPL
RHF484K1		Engineering model	-55°C to +125°C	Flat-14 W	Gold	0.70 g	-
RHF484K-01V	5962F08222	Flight model					-

Note: Contact your ST sales office for information on specific conditions for products in die form.

1 Absolute maximum ratings and operating conditions

Table 2. Absolute maximum ratings

Symbol	Parameter	Value	Unit
V_{CC}	Supply voltage (+ V_{CC})-(- V_{CC})	18	V
V_{id}	Differential input voltage ⁽¹⁾	± 1.2	V
V_{in}	Input voltage ⁽²⁾⁽³⁾	$-V_{CC} - 0.3V$ to $+V_{CC} + 0.3V$	V
I_{in}	Input current	45	mA
T_{stg}	Storage temperature range	-65 to +150	°C
T_j	Maximum junction temperature	150	°C
R_{thja}	Thermal resistance junction to ambient ⁽⁴⁾ Flat package, 14 pins	TBD	°C/W
R_{thjc}	Thermal resistance junction to case ⁽⁴⁾ Flat package, 14 pins	TBD	°C/W
ESD	HBM: human body model ⁽⁵⁾	2	kV
T_{Lead}	Lead temperature (soldering, 10 sec)	260	°C
Radiation informations			
Dose	Low dose rate of 0.01 rad.sec ⁻¹	100	kRad
	High dose rate of 50-300 rad.sec ⁻¹	300	kRad
Heavy ions	SEL immunity (at 125°C)	120	MeV.cm ² /mg
	SET characterized		

- The differential voltage is the voltage difference between the pins +IN and -IN of a channel.
- All voltage values, except differential voltage are with respect to network ground terminal.
- The voltage on either input must never exceed $+V_{CC} + 0.3 V$ nor 16 V.
- Short-circuits can cause excessive heating and destructive dissipation. Values are typical.
- Human body model: a 100 pF capacitor is charged to the specified voltage, then discharged through a 1.5 k Ω resistor between two pins of the device. This is done for all couples of connected pin combinations while the other pins are floating.

Table 3. Operating conditions

Symbol	Parameter	Value	Unit
(+ V_{CC})-(- V_{CC})	Supply voltage	4 to 14 ⁽¹⁾	V
V_{icm}	Common-mode input voltage range	$-V_{CC}$ to $+V_{CC}$	V
T_{oper}	Operating free-air temperature range	-55 to +125	°C

- SEL-free, up to 120 MeV.cm²/mg.

2 Electrical characteristics

Table 4. $+V_{CC} = 7\text{ V}$, $-V_{CC} = 7\text{ V}$, $V_{icm} = 0\text{ V}$, $T_{amb} = 25^\circ\text{C}$, loads (R_L, C_L) connected to GND (unless otherwise specified)

Symbol	Parameter	Test conditions	Temp.	Min.	Typ.	Max.	Unit		
DC performance									
V_{io}	Offset voltage	$V_{icm} = +7\text{ V}$	-55°C			700	μV		
			+25°C			500			
			+125°C			700			
		$V_{icm} = +0\text{ V}$	-55°C			500		60	300
			+25°C			500			
			+125°C			700			
		$V_{icm} = -7\text{ V}$	-55°C			700			500
			+25°C			500			
			+125°C			700			
DV_{io}	Input offset voltage drift	No load			1		$\mu\text{V}/^\circ\text{C}$		
I_{ib}	Input bias current	No load	-55°C			100	nA		
			+25°C			6			
			+125°C			100			
DI_{ib}	Input offset current temp. drift	No load			100		$\text{pA}/^\circ\text{C}$		
I_{io}	Input offset current	No load $V_{out} = 0\text{ V}$	-55°C			35	nA		
			+25°C			2			
			+125°C			35			
C_{in}	Differential input capacitance between +IN and -IN		+25°C		8		pF		
	Input capacitance between +IN (or -IN) and GND		+25°C		2				
I_{CC}	Supply current per amplifier	No load	-55°C			2.9	mA		
			+25°C			2.2			
			+125°C			2.9			
CMR	Common mode rejection ratio	No load $-V_{CC} < V_{icm} < +V_{CC}$	-55°C	72			dB		
			+25°C	72	105				
			+125°C	72					
SVR	Supply rejection ratio	No load From $+V_{CC} = 2\text{ V}$ and $-V_{CC} = -2\text{ V}$ to $+V_{CC} = 7\text{ V}$ and $-V_{CC} = -7\text{ V}$	-55°C	80			dB		
			+25°C	90	120				
			+125°C	80					

Table 4. $+V_{CC} = 7\text{ V}$, $-V_{CC} = 7\text{ V}$, $V_{icm} = 0\text{ V}$, $T_{amb} = 25^\circ\text{C}$, loads (R_L, C_L) connected to GND (unless otherwise specified) (continued)

Symbol	Parameter	Test conditions	Temp.	Min.	Typ.	Max.	Unit
AC performance							
GBP	Gain bandwidth product	$V_{out} = 200\text{ mVpp}$ $f = 100\text{ kHz}$ $R_L = 1\text{ k}\Omega$ $C_L = 100\text{ pF}$	-55°C	3.5			MHz
			+25°C	6	8		
			+125°C	3.5			
F_u	Unity gain frequency	$R_L = 1\text{ k}\Omega$ $C_L = 100\text{ pF}$	+25°C		5		MHz
ϕ_m	Phase margin	$R_L = 1\text{ k}\Omega$ $C_L = 100\text{ pF}$ $G = +5$	+25°C		50		Degrees
A_{VD}	Large signal voltage gain	$R_L = 10\text{ k}\Omega$ $V_{out} = -6.5\text{ V to } 6\text{ V}$	-55°C	60			dB
			+25°C	74	85		
			+125°C	60			
SR	Slew rate	$R_L = 1\text{ k}\Omega$ $V_{out} = -4.8\text{ V to } 4.8\text{ V}$ $V_{out} = 4.8\text{ V to } -4.8\text{ V}$	-55°C	1.7			$\text{V}/\mu\text{s}$
			+25°C	2	3.5		
			+125°C	1.7			
e_n	Equivalent input noise voltage	No load, $f = 1\text{ kHz}$	+25°C		7		$\frac{\text{nV}}{\sqrt{\text{Hz}}}$
i_n	Equivalent input noise current	No load, $f = 1\text{ kHz}$	+25°C		0.8		$\frac{\text{pA}}{\sqrt{\text{Hz}}}$
THD+ e_n	Total harmonic distortion + noise	$V_{out} = 13\text{ Vpp}$, $R_L = 1\text{ k}\Omega$ $C_L = 100\text{ pF}$ $G = -5.1$	+25°C		0.01		%
Output characteristics							
V_{OH}	High level output voltage	$+V_{CC} = 14\text{ V}$, $-V_{CC} = 0\text{ V}$ $R_L = 1\text{ k}\Omega$	-55°C	13.5			V
			+25°C	13.6	13.8		
			+125°C	13.5			
		$+V_{CC} = 14\text{ V}$, $-V_{CC} = 0\text{ V}$ $R_L = 10\text{ k}\Omega$	-55°C	13.6			V
			+25°C	13.8	13.9		
			+125°C	13.6			
V_{OL}	Low level output voltage	$+V_{CC} = 14\text{ V}$, $-V_{CC} = 0\text{ V}$ $R_L = 1\text{ k}\Omega$	-55°C			0.3	V
			+25°C		0.12	0.2	
			+125°C			0.3	
		$+V_{CC} = 14\text{ V}$, $-V_{CC} = 0\text{ V}$ $R_L = 10\text{ k}\Omega$	-55°C			0.2	V
			+25°C		0.04	0.08	
			+125°C			0.2	

Table 4. $+V_{CC} = 7\text{ V}$, $-V_{CC} = 7\text{ V}$, $V_{icm} = 0\text{ V}$, $T_{amb} = 25^\circ\text{C}$, loads (R_L, C_L) connected to GND
(unless otherwise specified) (continued)

Symbol	Parameter	Test conditions	Temp.	Min.	Typ.	Max.	Unit
$I_{out}^{(1)}$	Output sink current	$V_{out} = +V_{CC}$ No load, $V_{id} = -1\text{ V}$	-55°C	15			mA
			+25°C	20	35		
			+125°C	15			
	Output source current	$V_{out} = -V_{CC}$ No load, $V_{id} = +1\text{ V}$	-55°C	10			mA
			+25°C	15	30		
			+125°C	10			

1. These tests are performed during a very short period of time. Excessive heating can damage the device. In the application, the junction temperature must never exceed 150°C as specified in [Table 2](#).

Table 5. $+V_{CC} = +2\text{ V}$, $-V_{CC} = -2\text{ V}$, $V_{icm} = 0\text{ V}$, $T_{amb} = 25^\circ\text{C}$, loads (R_L, C_L) connected to GND (unless otherwise specified)

Symbol	Parameter	Test conditions	Temp.	Min.	Typ.	Max.	Unit		
DC performance									
V_{io}	Offset voltage	$V_{icm} = +2\text{ V}$	-55°C			700	μV		
			+25°C			500			
			+125°C			700			
		$V_{icm} = +0\text{ V}$	-55°C			500		60	300
			+25°C			500			
			+125°C			700			
		$V_{icm} = -2\text{ V}$	-55°C			500			700
			+25°C			500			
			+125°C			700			
DV_{io}	Input offset voltage drift	No load			1		$\mu\text{V}/^\circ\text{C}$		
I_{ib}	Input bias current	No load	-55°C			100	nA		
			+25°C		11	60			
			+125°C			100			
DI_{ib}	Input offset current temp. drift	No load			100		$\text{pA}/^\circ\text{C}$		
I_{io}	Input offset current	No load $V_{out} = 0\text{ V}$	-55°C			35	nA		
			+25°C		2	15			
			+125°C			35			
C_{in}	Differential input capacitance between +IN and -IN		+25°C		8		pF		
	Input capacitance between +IN (or -IN) and GND		+25°C		2				
I_{CC}	Supply current per amplifier	No load	-55°C			2.6	mA		
			+25°C		2	2.6			
			+125°C			2.6			
CMR	Common mode rejection ratio	No load $-V_{CC} < V_{icm} < +V_{CC}$	-55°C	72			dB		
			+25°C	72	95				
			+125°C	72					

Table 5. $+V_{CC} = +2\text{ V}$, $-V_{CC} = -2\text{ V}$, $V_{icm} = 0\text{ V}$, $T_{amb} = 25^\circ\text{C}$, loads (R_L, C_L) connected to GND (unless otherwise specified) (continued)

Symbol	Parameter	Test conditions	Temp.	Min.	Typ.	Max.	Unit
AC performance							
GBP	Gain bandwidth product	$V_{out} = 200\text{ mVpp}$ $f = 100\text{ kHz}$ $R_L = 1\text{ k}\Omega$ $C_L = 100\text{ pF}$	-55°C	3.5			MHz
			+25°C	6	8		
			+125°C	3.5			
F_u	Unity gain frequency	$R_L = 1\text{ k}\Omega$ $C_L = 100\text{ pF}$	+25°C		5		MHz
ϕ_m	Phase margin	$R_L = 1\text{ k}\Omega$ $C_L = 100\text{ pF}$ $G = +5$	+25°C		50		Degrees
A_{VD}	Large signal voltage gain	$R_L = 10\text{ k}\Omega$ $V_{out} = -1.5\text{ V to } 0.5\text{ V}$	-55°C	60			dB
			+25°C	70	80		
			+125°C	60			
SR	Slew rate	$R_L = 1\text{ k}\Omega$ $V_{out} = -1.28\text{ V to } 1.28\text{ V}$ $V_{out} = 1.28\text{ V to } -1.28\text{ V}$	-55°C	1.7			V/ μ s
			+25°C	2	3.1		
			+125°C	1.7			
e_n	Equivalent input noise voltage	No load, $f = 1\text{ kHz}$	+25°C		7.5		$\frac{nV}{\sqrt{Hz}}$
i_n	Equivalent input noise current	No load, $f = 1\text{ kHz}$	+25°C		0.8		$\frac{pA}{\sqrt{Hz}}$
THD+ e_n	Total harmonic distortion + noise	$V_{out} = 3\text{ Vpp}$, $R_L = 1\text{ k}\Omega$ $C_L = 100\text{ pF}$ $G = -5.1$	+25°C		0.01		%
Output characteristics							
V_{OH}	High level output voltage	$+V_{CC} = 4\text{ V}$, $-V_{CC} = 0\text{ V}$ $R_L = 1\text{ k}\Omega$	-55°C	3.75			V
			+25°C	3.8	3.9		
			+125°C	3.75			
		$+V_{CC} = 4\text{ V}$, $-V_{CC} = 0\text{ V}$ $R_L = 10\text{ k}\Omega$	-55°C	3.75			V
			+25°C	3.85	3.95		
			+125°C	3.75			
V_{OL}	Low level output voltage	$+V_{CC} = 4\text{ V}$, $-V_{CC} = 0\text{ V}$ $R_L = 1\text{ k}\Omega$	-55°C			0.2	V
			+25°C		0.05	0.1	
			+125°C			0.2	
		$+V_{CC} = 4\text{ V}$, $-V_{CC} = 0\text{ V}$ $R_L = 10\text{ k}\Omega$	-55°C			0.1	V
			+25°C		0.03	0.07	
			+125°C			0.1	

Table 5. $+V_{CC} = +2\text{ V}$, $-V_{CC} = -2\text{ V}$, $V_{icm} = 0\text{ V}$, $T_{amb} = 25^\circ\text{C}$, loads (R_L, C_L) connected to GND (unless otherwise specified) (continued)

Symbol	Parameter	Test conditions	Temp.	Min.	Typ.	Max.	Unit
$I_{out}^{(1)}$	Output sink current	$V_{out} = +V_{CC}$ No load $V_{id} = -1\text{ V}$	-55°C	15			mA
			+25°C	20	35		
			+125°C	15			
	Output source current	$V_{out} = -V_{CC}$ No load $V_{id} = +1\text{ V}$	-55°C	10			mA
			+25°C	15	30		
			+125°C	10			

1. These tests are performed during a very short period of time. Excessive heating can damage the device. In the application, the junction temperature must never exceed 150°C as specified in [Table 2](#).

Figure 1. Input offset voltage distribution

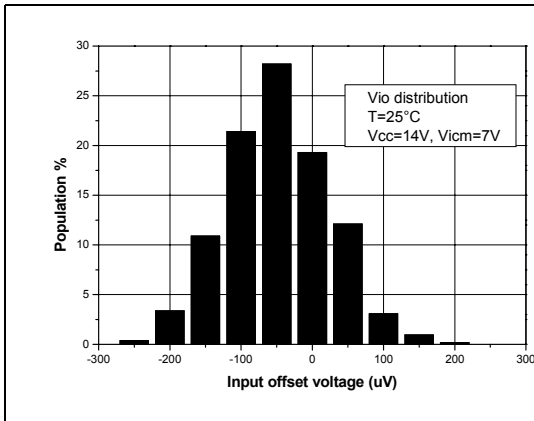

Figure 2. Input bias current vs. supply voltage

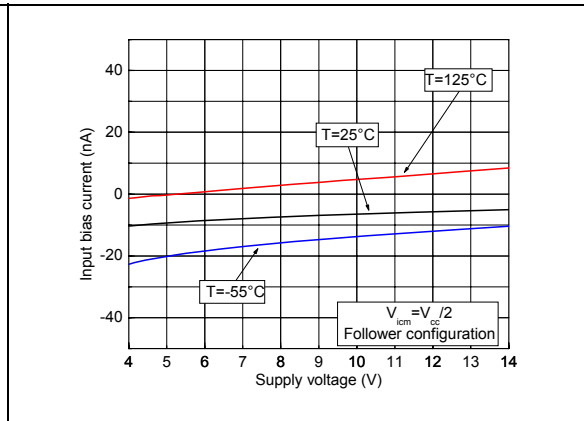

Figure 3. Input bias current vs. Vicm at V_{CC} = 4 V

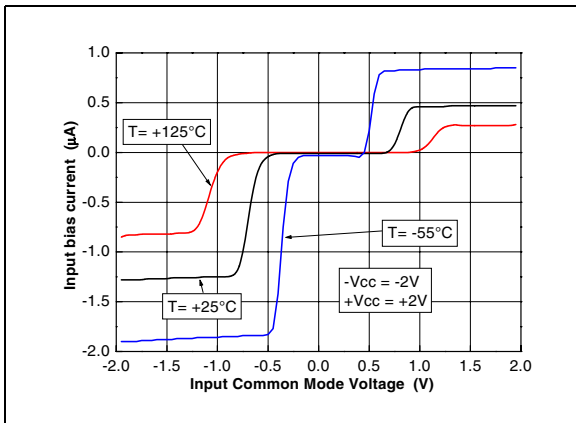

Figure 4. Input bias current vs. Vicm at V_{CC} = 14 V

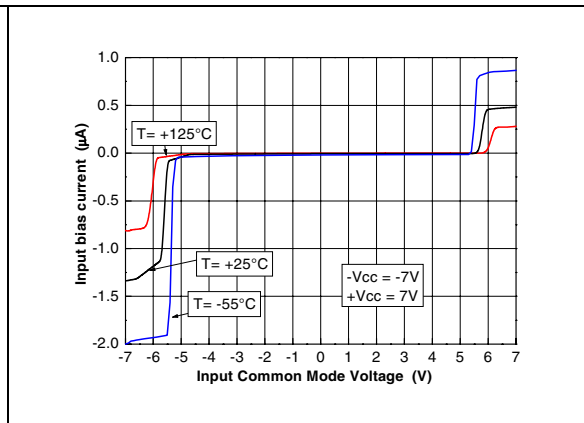

Figure 5. Supply current vs. Vicm in follower configuration at V_{CC} = 4 V

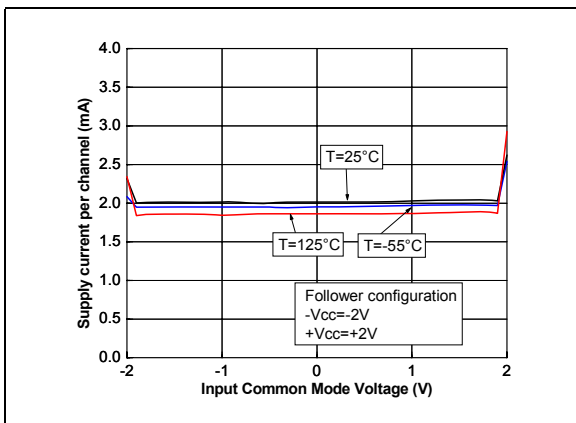

Figure 6. Supply current vs. Vicm in follower configuration at V_{CC} = 14 V

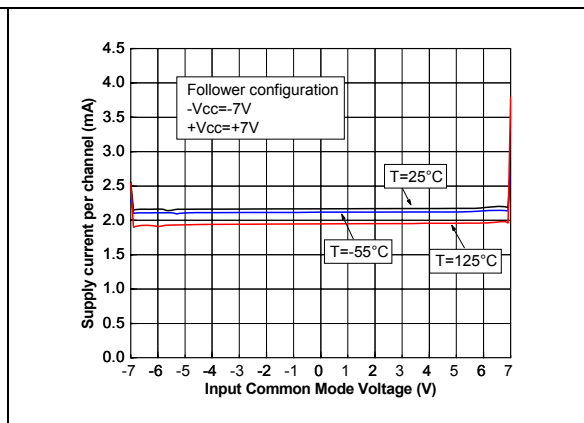

Figure 7. Supply current vs. supply voltage at $V_{icm} = V_{CC}/2$

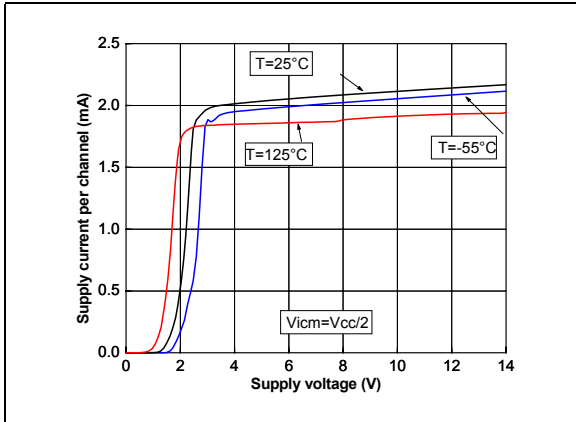

Figure 8. Output current vs. supply voltage at $V_{icm} = V_{CC}/2$

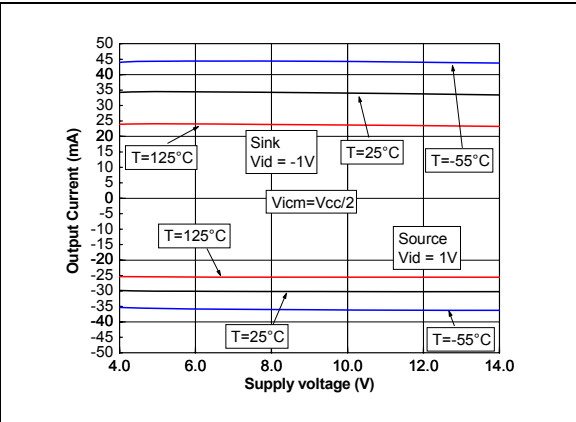

Figure 9. Output current vs. output voltage at $V_{CC} = 4 V$

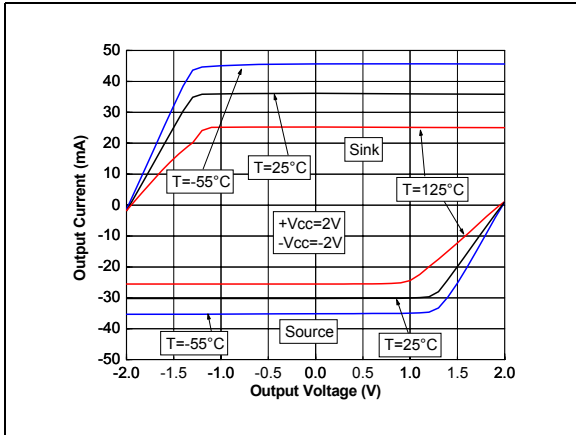

Figure 10. Output current vs. output voltage at $V_{CC} = 14 V$

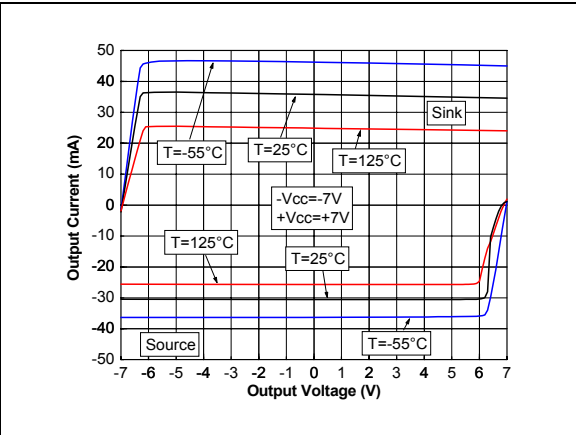

Figure 11. Differential input voltage vs. output voltage at $V_{CC} = 4 V$

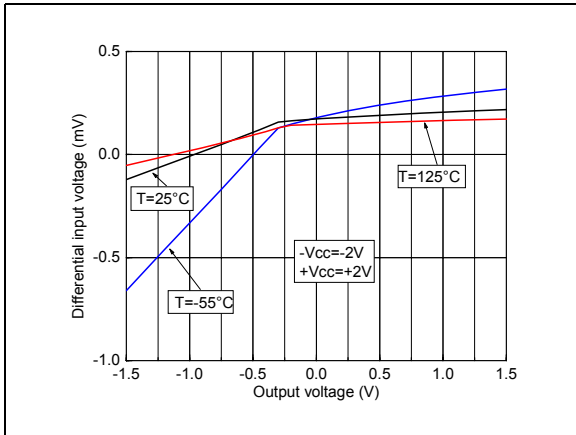

Figure 12. Differential input voltage vs. output voltage at $V_{CC} = 14 V$

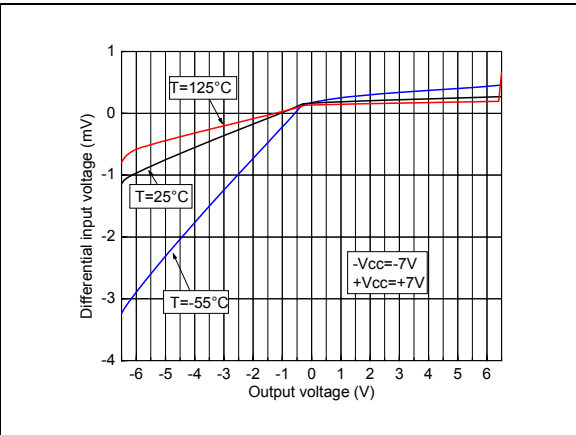

Figure 13. Noise vs. frequency at $V_{CC}=4\text{ V}$ and $V_{CC}=14\text{ V}$ **Figure 14. Voltage gain and phase vs. frequency at $V_{CC}=4\text{ V}$, $V_{icm}=2\text{ V}$**

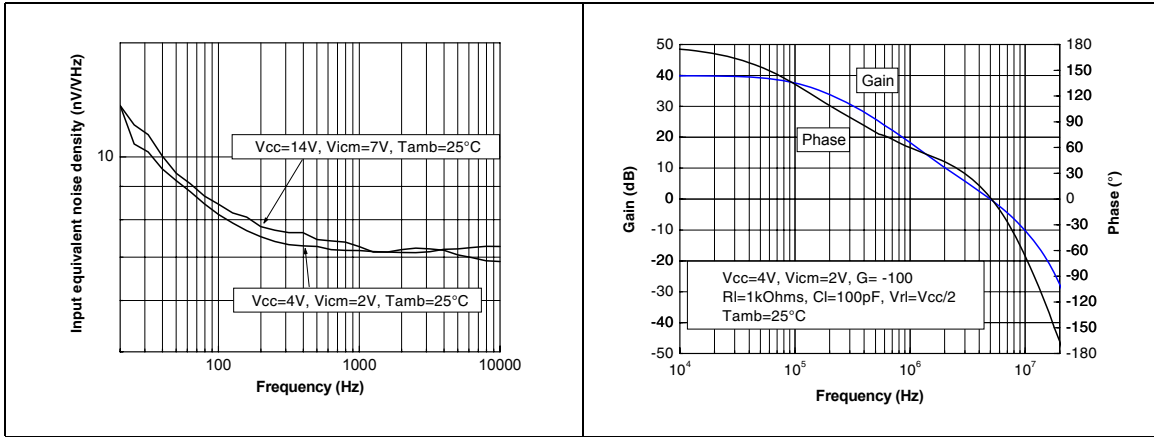

Figure 15. Voltage gain and phase vs. frequency at $V_{CC}=4\text{ V}$, $V_{icm}=3.5\text{ V}$ **Figure 16. Voltage gain and phase vs. frequency at $V_{CC}=4\text{ V}$, $V_{icm}=0.5\text{ V}$**

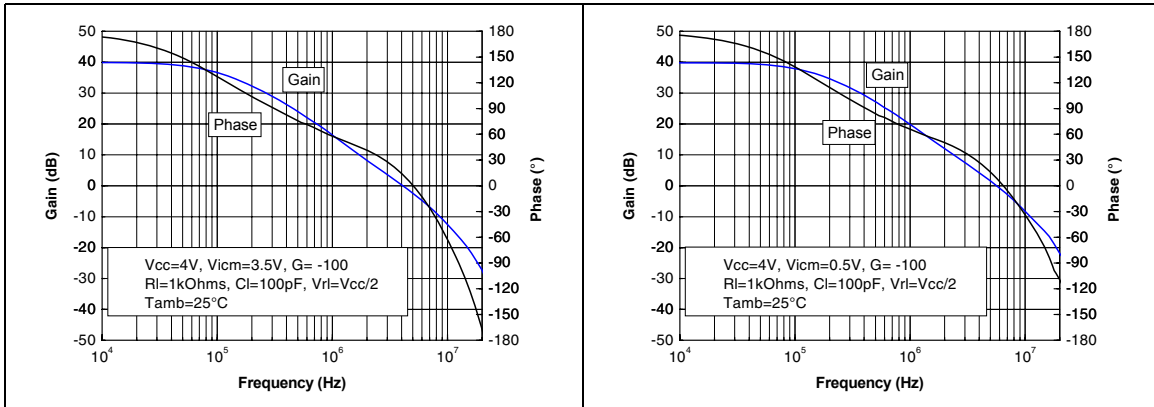

Figure 17. Voltage gain and phase vs. frequency at $V_{CC}=14\text{ V}$, $V_{icm}=7\text{ V}$ **Figure 18. Voltage gain and phase vs. frequency at $V_{CC}=14\text{ V}$, $V_{icm}=13.5\text{ V}$**

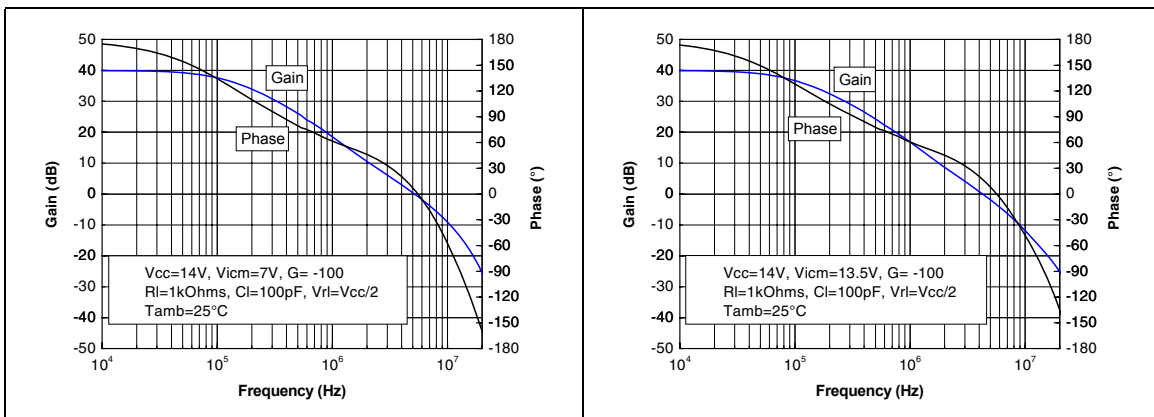

Figure 19. Voltage gain and phase vs. frequency at $V_{CC} = 14\text{ V}$, $V_{icm} = 0.5\text{ V}$

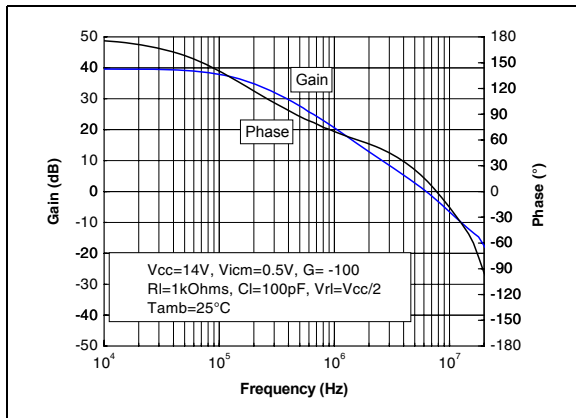

Figure 20. Positive slew rate at $V_{CC} = 4\text{ V}$

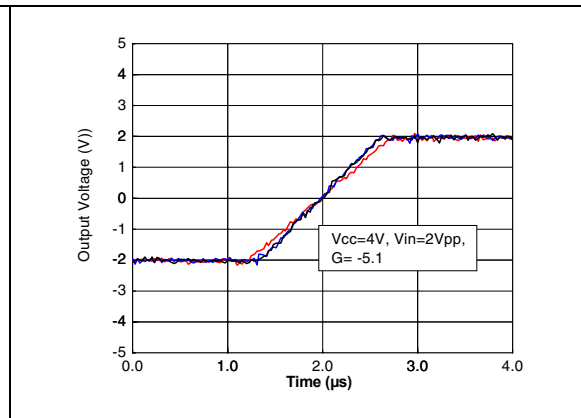

Figure 21. Negative slew rate at $V_{CC} = 4\text{ V}$

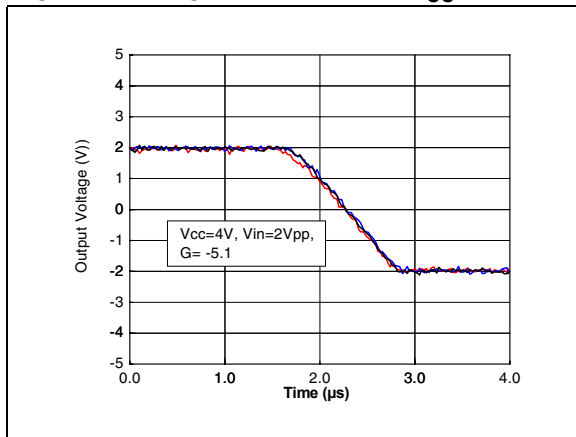

Figure 22. Positive slew rate at $V_{CC} = 14\text{ V}$

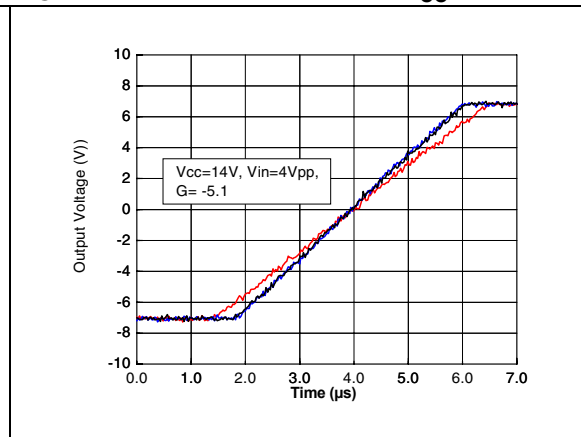
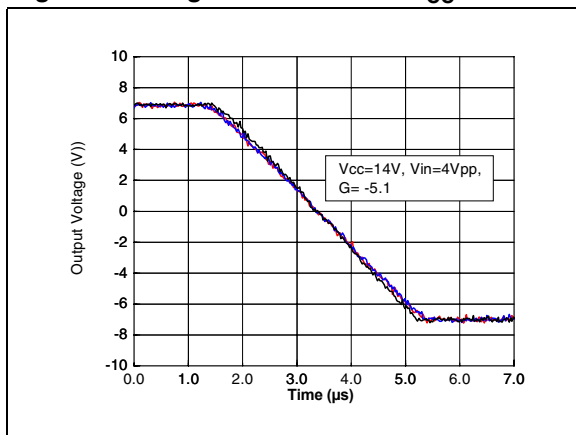

Figure 23. Negative slew rate at $V_{CC} = 14\text{ V}$



3 Achieving good stability at low gain

At low frequencies, the RHF484 can be used in a low gain configuration as shown in [Figure 24](#). At lower frequencies, the stability is not affected by the value of the gain, which can be set close to 1 V/V (0 dB), and is reduced to its simplest expression $G1=1+Rfb/Rg$. Therefore, an R-C cell is added in the gain network so that the gain is increased (up to 5) at higher frequencies (where the stability of the amplifier could be affected). At higher frequencies, the gain becomes $G2=1+Rfb/(Rg//R)$.

Figure 24. Low gain configuration

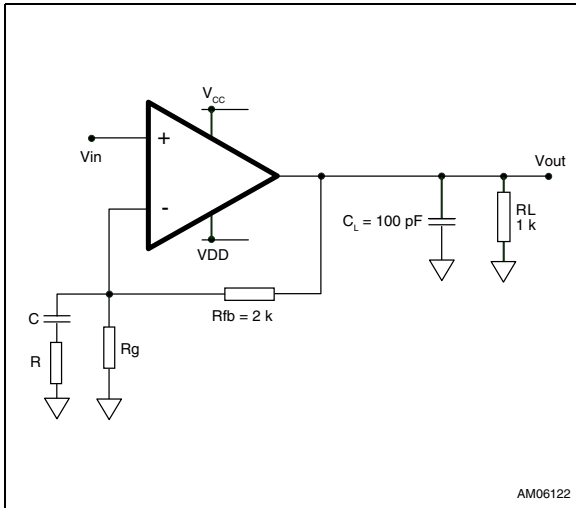
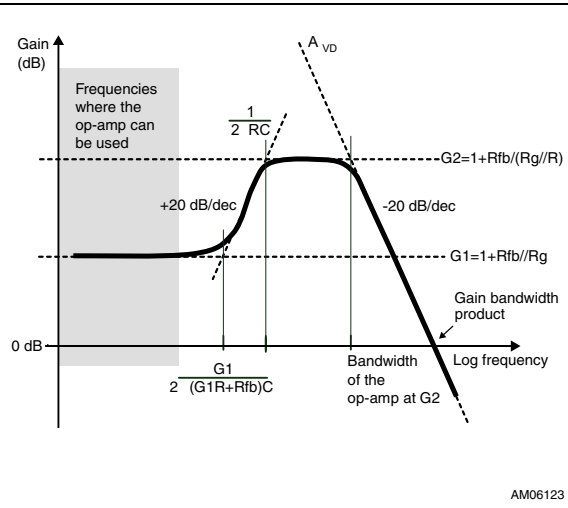

Figure 25. Closed-loop gain



Rg becomes a complex impedance. The closed-loop gain features a variation in frequency and can be expressed as:

$$\text{Gain} = G1 \frac{1 + jC\omega \times \left(\frac{G1R + Rfb}{G1} \right)}{1 + jCR\omega}$$

where a pole appears at $1/2\pi RC$ and a zero at $G1/2\pi(G1R+Rfb)C$. The frequency can be plotted as shown in [Figure 25](#).

Table 6. External components versus low-frequency gain

G1 (V/V)	R (Ω)	C (nF)	Rg (Ω)	Rfb (Ω)
1.1	510	1	20k	2k
2	510	1	2k	2k
3	510	1	1k	2k
4	510	1	750	2.4k
5	Not connected	Not connected	820	3.3k

4 Package information

In order to meet environmental requirements, ST offers these devices in different grades of ECOPACK[®] packages, depending on their level of environmental compliance. ECOPACK[®] specifications, grade definitions and product status are available at: www.st.com. ECOPACK[®] is an ST trademark.

Figure 26. Wide ceramic Flat-14 package mechanical drawing.

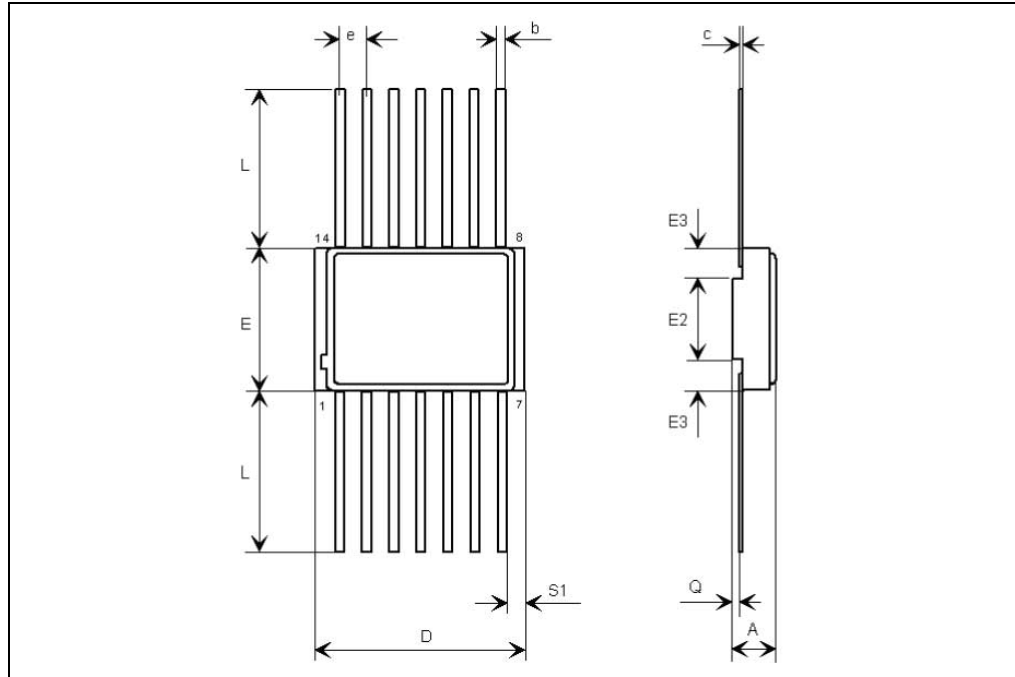

Note: The upper metallic lid is not electrically connected to any pins, nor to the IC die inside the package. Connecting unused pins or metal lid to ground or Vcc will not affect the electrical characteristics.

Table 7. Wide ceramic Flat-14 W package mechanical data

Ref.	Dimensions					
	Millimeters			inches		
	Min.	Typ.	Max.	Min.	Typ.	Max.
A	1.93	2.11	2.29	.076	.083	.090
b	0.38	0.43	0.48	.015	.017	.019
c	0.10	0.13	0.18	.004	.005	.007
D	9.71	9.91	10.11	.382	0.390	.398
E	7.27	7.42	7.57	.286	.292	.298
E2		5.4			.213	
E3	0.76			.030		
e		1.27			.050	
L	6.3		6.6	.248		.260
Q	0.20		0.28	.008		.011
S1	0.13			.005		

5 Ordering information

Table 8. Order codes

Order code	Description	Temperature range	Package	Marking
RHF484K1	Engineering Samples	-55°C to +125°C	Flat-14 W	RHF484K1
RHF484K-01V	Flight Models			5962F0822201VXC

Note: Contact your ST sales office for information on specific conditions for products in die form.

6 Revision history

Table 9. Document revision history

Date	Revision	Changes
26-Apr-2011	1	Initial release.

Please Read Carefully:

Information in this document is provided solely in connection with ST products. STMicroelectronics NV and its subsidiaries ("ST") reserve the right to make changes, corrections, modifications or improvements, to this document, and the products and services described herein at any time, without notice.

All ST products are sold pursuant to ST's terms and conditions of sale.

Purchasers are solely responsible for the choice, selection and use of the ST products and services described herein, and ST assumes no liability whatsoever relating to the choice, selection or use of the ST products and services described herein.

No license, express or implied, by estoppel or otherwise, to any intellectual property rights is granted under this document. If any part of this document refers to any third party products or services it shall not be deemed a license grant by ST for the use of such third party products or services, or any intellectual property contained therein or considered as a warranty covering the use in any manner whatsoever of such third party products or services or any intellectual property contained therein.

UNLESS OTHERWISE SET FORTH IN ST'S TERMS AND CONDITIONS OF SALE ST DISCLAIMS ANY EXPRESS OR IMPLIED WARRANTY WITH RESPECT TO THE USE AND/OR SALE OF ST PRODUCTS INCLUDING WITHOUT LIMITATION IMPLIED WARRANTIES OF MERCHANTABILITY, FITNESS FOR A PARTICULAR PURPOSE (AND THEIR EQUIVALENTS UNDER THE LAWS OF ANY JURISDICTION), OR INFRINGEMENT OF ANY PATENT, COPYRIGHT OR OTHER INTELLECTUAL PROPERTY RIGHT.

UNLESS EXPRESSLY APPROVED IN WRITING BY AN AUTHORIZED ST REPRESENTATIVE, ST PRODUCTS ARE NOT RECOMMENDED, AUTHORIZED OR WARRANTED FOR USE IN MILITARY, AIR CRAFT, SPACE, LIFE SAVING, OR LIFE SUSTAINING APPLICATIONS, NOR IN PRODUCTS OR SYSTEMS WHERE FAILURE OR MALFUNCTION MAY RESULT IN PERSONAL INJURY, DEATH, OR SEVERE PROPERTY OR ENVIRONMENTAL DAMAGE. ST PRODUCTS WHICH ARE NOT SPECIFIED AS "AUTOMOTIVE GRADE" MAY ONLY BE USED IN AUTOMOTIVE APPLICATIONS AT USER'S OWN RISK.

Resale of ST products with provisions different from the statements and/or technical features set forth in this document shall immediately void any warranty granted by ST for the ST product or service described herein and shall not create or extend in any manner whatsoever, any liability of ST.

ST and the ST logo are trademarks or registered trademarks of ST in various countries.

Information in this document supersedes and replaces all information previously supplied.

The ST logo is a registered trademark of STMicroelectronics. All other names are the property of their respective owners.

© 2011 STMicroelectronics - All rights reserved

STMicroelectronics group of companies

Australia - Belgium - Brazil - Canada - China - Czech Republic - Finland - France - Germany - Hong Kong - India - Israel - Italy - Japan - Malaysia - Malta - Morocco - Philippines - Singapore - Spain - Sweden - Switzerland - United Kingdom - United States of America

www.st.com