

RAD-HARD DUAL 4-INPUT NAND GATE

- HIGH SPEED:
 $t_{PD} = 9\text{ns}$ (TYP.) at $V_{CC} = 6\text{V}$
- LOW POWER DISSIPATION:
 $I_{CC} = 1\mu\text{A}$ (MAX.) at $T_A=25^\circ\text{C}$
- HIGH NOISE IMMUNITY:
 $V_{NIH} = V_{NIL} = 28\% V_{CC}$ (MIN.)
- SYMMETRICAL OUTPUT IMPEDANCE:
 $|I_{OH}| = I_{OL} = 4\text{mA}$ (MIN) at $V_{CC} = 4.5\text{V}$
- BALANCED PROPAGATION DELAYS:
 $t_{PLH} \cong t_{PHL}$
- WIDE OPERATING VOLTAGE RANGE:
 V_{CC} (OPR) = 2V to 6V
- PIN AND FUNCTION COMPATIBLE WITH 54 SERIES 20
- SPACE GRADE-1: ESA SCC QUALIFIED
- 50 krad QUALIFIED, 100 krad AVAILABLE ON REQUEST
- NO SEL UNDER HIGH LET HEAVY IONS IRRADIATION
- DEVICE FULLY COMPLIANT WITH SCC-9201-118

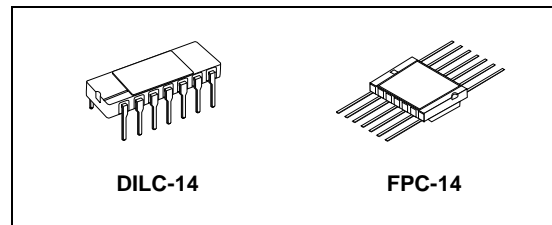

ORDER CODES

PACKAGE	FM	EM
DILC	M54HC20D	M54HC20D1
FPC	M54HC20K	M54HC20K1

The internal circuit is composed of 3-stage including buffered output, which gives high noise immunity and stable output.

All inputs are equipped with protection circuits against static discharge and transient excess voltage.

DESCRIPTION

The M54HC20 is an high speed CMOS DUAL 4-INPUT NAND GATE fabricated with silicon gate C²MOS technology.

PIN CONNECTION

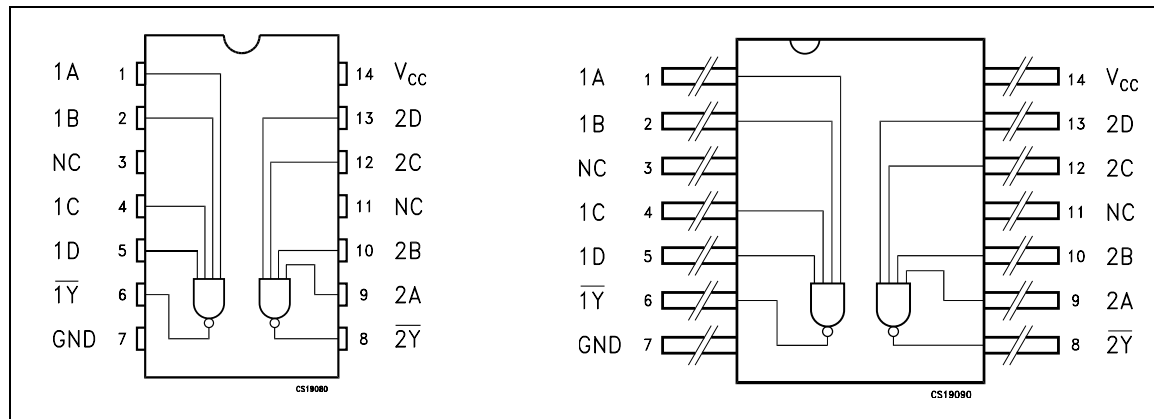

M54HC20

IEC LOGIC SYMBOLS

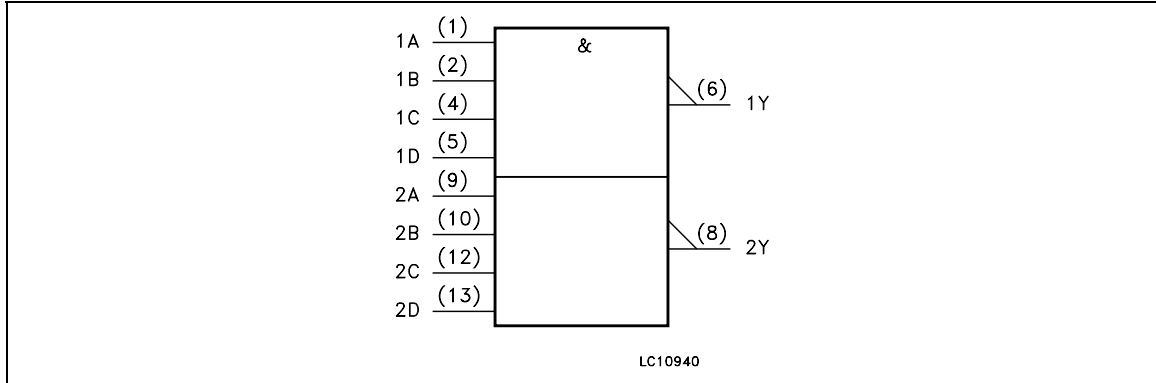

INPUT AND OUTPUT EQUIVALENT CIRCUIT

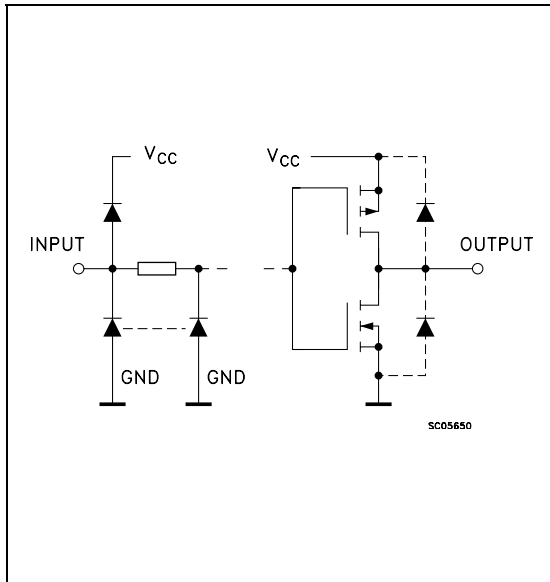

PIN DESCRIPTION

PIN N°	SYMBOL	NAME AND FUNCTION
1, 9	1A, 2A	Data Inputs
2, 10	1B, 2B	Data Inputs
3, 11	N.C.	Not Connected
4, 12	1C, 2C	Data Inputs
5, 13	1D, 2D	Data Inputs
6, 8	$\overline{1Y}$, $\overline{2Y}$	Data Outputs
7	GND	Ground (0V)
14	V _{CC}	Positive Supply Voltage

TRUTH TABLE

A	B	C	D	Y
L	X	X	X	H
X	L	X	X	H
X	X	L	X	H
X	X	X	L	H
H	H	H	H	L

ABSOLUTE MAXIMUM RATINGS

Symbol	Parameter	Value	Unit
V _{CC}	Supply Voltage	-0.5 to +7	V
V _I	DC Input Voltage	-0.5 to V _{CC} + 0.5	V
V _O	DC Output Voltage	-0.5 to V _{CC} + 0.5	V
I _{IK}	DC Input Diode Current	± 20	mA
I _{OK}	DC Output Diode Current	± 20	mA
I _O	DC Output Current	± 25	mA
I _{CC} or I _{GND}	DC V _{CC} or Ground Current	± 50	mA
P _D	Power Dissipation	300	mW
T _{stg}	Storage Temperature	-65 to +150	°C
T _L	Lead Temperature (10 sec)	265	°C

Absolute Maximum Ratings are those values beyond which damage to the device may occur. Functional operation under these conditions is not implied.

RECOMMENDED OPERATING CONDITIONS

Symbol	Parameter	Value	Unit	
V_{CC}	Supply Voltage	2 to 6	V	
V_I	Input Voltage	0 to V_{CC}	V	
V_O	Output Voltage	0 to V_{CC}	V	
T_{op}	Operating Temperature	-55 to 125	°C	
t_r, t_f	Input Rise and Fall Time	$V_{CC} = 2.0V$	0 to 1000	ns
		$V_{CC} = 4.5V$	0 to 500	ns
		$V_{CC} = 6.0V$	0 to 400	ns

DC SPECIFICATIONS

Symbol	Parameter	Test Condition		Value						Unit	
				$T_A = 25^\circ C$			-40 to 85°C		-55 to 125°C		
				Min.	Typ.	Max.	Min.	Max.	Min.		Max.
V_{IH}	High Level Input Voltage	V_{CC} (V)		1.5			1.5		1.5	V	
				3.15			3.15		3.15		
				4.2			4.2		4.2		
V_{IL}	Low Level Input Voltage	V_{CC} (V)				0.5		0.5		0.5	V
						1.35		1.35		1.35	
						1.8		1.8		1.8	
V_{OH}	High Level Output Voltage	V_{CC} (V)	$I_O = -20 \mu A$	1.9	2.0		1.9		1.9	V	
			$I_O = -20 \mu A$	4.4	4.5		4.4		4.4		
			$I_O = -20 \mu A$	5.9	6.0		5.9		5.9		
			$I_O = -4 \text{ mA}$	4.18	4.31		4.13		4.10		
			$I_O = -5.2 \text{ mA}$	5.68	5.8		5.63		5.60		
V_{OL}	Low Level Output Voltage	V_{CC} (V)	$I_O = 20 \mu A$		0.0	0.1		0.1		0.1	V
			$I_O = 20 \mu A$		0.0	0.1		0.1		0.1	
			$I_O = 20 \mu A$		0.0	0.1		0.1		0.1	
			$I_O = 4 \text{ mA}$		0.17	0.26		0.33		0.40	
			$I_O = 5.2 \text{ mA}$		0.18	0.26		0.33		0.40	
I_I	Input Leakage Current	6.0	$V_I = V_{CC}$ or GND			± 0.1		± 1		± 1	μA
I_{CC}	Quiescent Supply Current	6.0	$V_I = V_{CC}$ or GND			1		10		20	μA

M54HC20

AC ELECTRICAL CHARACTERISTICS ($C_L = 50 \text{ pF}$, Input $t_r = t_f = 6 \text{ ns}$)

Symbol	Parameter	Test Condition		Value						Unit	
		V_{CC} (V)		$T_A = 25^\circ\text{C}$			$-40 \text{ to } 85^\circ\text{C}$		$-55 \text{ to } 125^\circ\text{C}$		
				Min.	Typ.	Max.	Min.	Max.	Min.		Max.
t_{LH} t_{HL}	Output Transition Time	2.0			30	75		95		110	ns
		4.5			8	15		19		22	
		6.0			7	13		16		19	
t_{pLH} t_{pHL}	Propagation Delay Time	2.0			30	80		100		120	ns
		4.5			10	16		20		24	
		6.0			9	14		17		20	

CAPACITANCE CHARACTERISTICS

Symbol	Parameter	Test Condition		Value						Unit	
		V_{CC} (V)		$T_A = 25^\circ\text{C}$			$-40 \text{ to } 85^\circ\text{C}$		$-55 \text{ to } 125^\circ\text{C}$		
				Min.	Typ.	Max.	Min.	Max.	Min.		Max.
C_{IN}	Input Capacitance	5.0			5	10		10		10	pF
C_{PD}	Power Dissipation Capacitance (note 1)	5.0			27						pF

1) C_{PD} is defined as the value of the IC's internal equivalent capacitance which is calculated from the operating current consumption without load. (Refer to Test Circuit). Average operating current can be obtained by the following equation. $I_{CC(oper)} = C_{PD} \times V_{CC} \times f_{IN} + I_{CC}/2$ (per gate)

TEST CIRCUIT

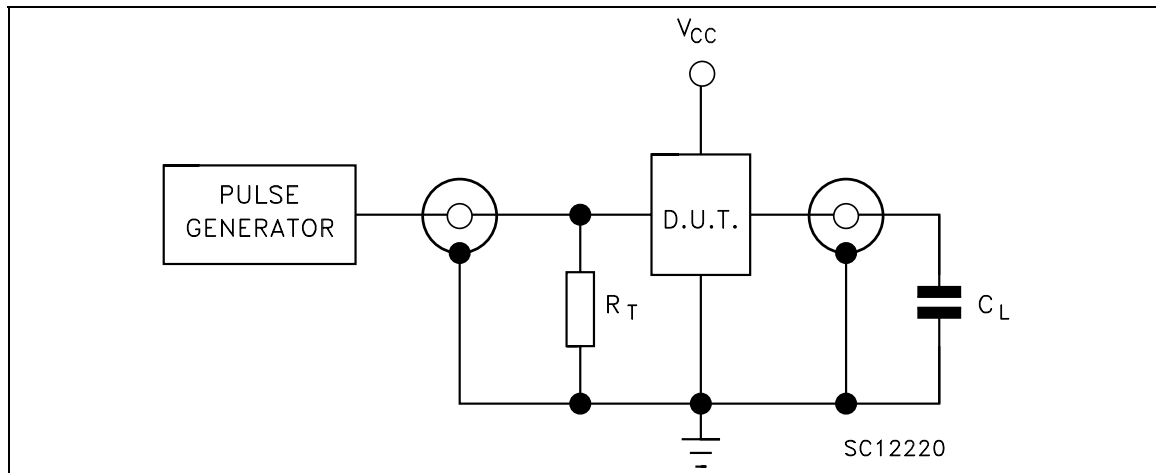

$C_L = 50 \text{ pF}$ or equivalent (includes jig and probe capacitance)
 $R_T = Z_{OUT}$ of pulse generator (typically 50Ω)

WAVEFORM 1: PROPAGATION DELAY TIME (f=1MHz; 50% duty cycle)

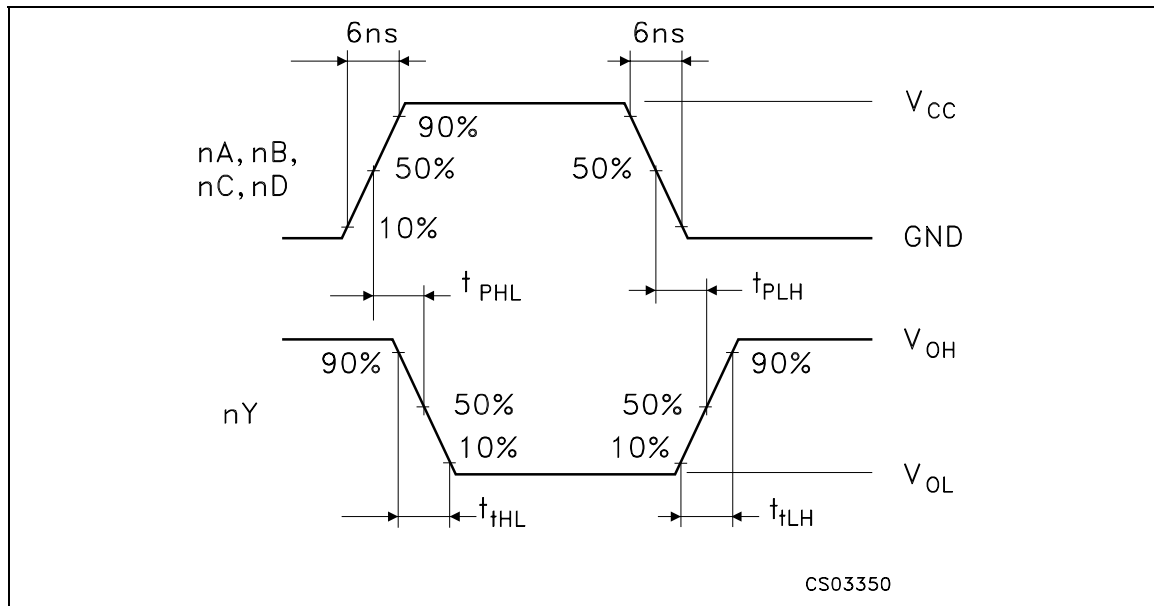

DILC-14 MECHANICAL DATA

DIM.	mm.			inch		
	MIN.	TYP	MAX.	MIN.	TYP.	MAX.
A	2.1		22.54	0.083		0.100
a1	3.00		3.70	0.118		0.146
a2	0.63	0.88	1.14	0.025	0.035	0.045
B	1.82	2.03	2.39	0.072	0.080	0.094
b	0.40	0.45	0.50	0.016	0.018	0.020
b1	0.20	0.254	0.30	0.008	0.010	0.012
D	18.79	19.00	19.20	0.740	0.748	0.756
e	7.36	7.62	7.87	0.290	0.300	0.310
e1		2.54			0.100	
e2	15.11	15.24	15.37	0.595	0.600	0.605
e3	7.62	7.87	8.12	0.300	0.310	0.320
F	7.11		7.75	0.280		0.305
I			3.70			0.146
K	10.90		12.1	0.429		0.476
L	1.14	1.27	1.5	0.045	0.050	0.059

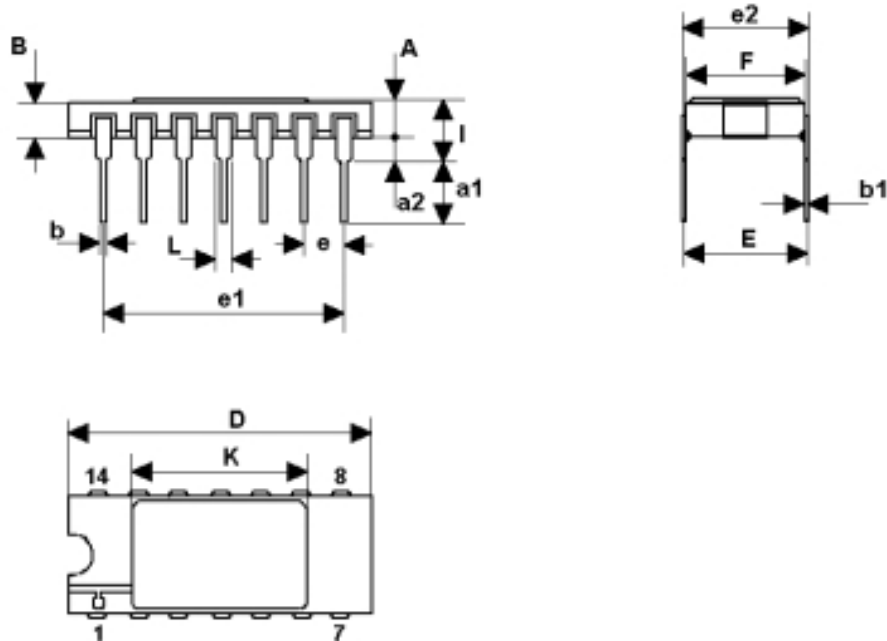

0016173H

FPC-14 MECHANICAL DATA

DIM.	mm.			inch		
	MIN.	TYP	MAX.	MIN.	TYP.	MAX.
A	6.75	6.91	7.06	0.266	0.272	0.278
B	9.76	9.95	10.14	0.384	0.392	0.399
C	1.49		1.95	0.059		0.077
D	0.10	0.127	0.15	0.004	0.005	0.006
E	7.50	7.62	7.75	0.295	0.300	0.305
F		1.27			0.050	
G	0.38	0.43	0.48	0.015	0.017	0.019
H		6.0			0.236	
L	18.75		22.0	0.738		0.866
M		0.38			0.015	
N		4.31			0.170	

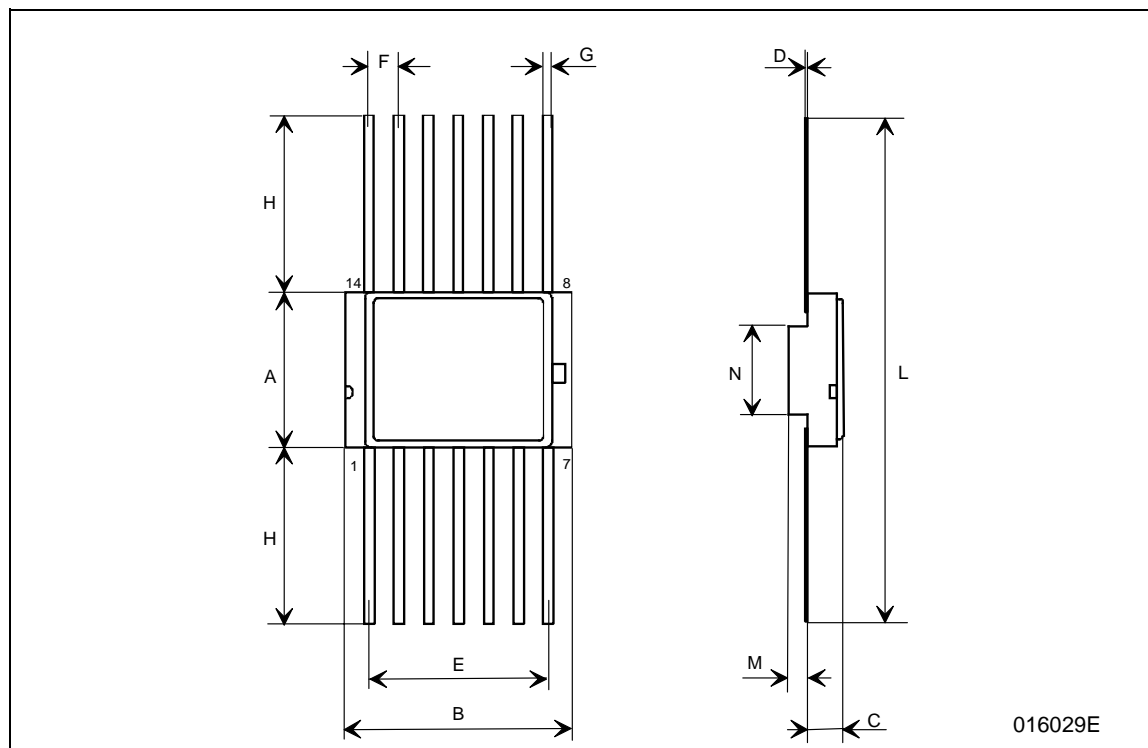

Information furnished is believed to be accurate and reliable. However, STMicroelectronics assumes no responsibility for the consequences of use of such information nor for any infringement of patents or other rights of third parties which may result from its use. No license is granted by implication or otherwise under any patent or patent rights of STMicroelectronics. Specifications mentioned in this publication are subject to change without notice. This publication supersedes and replaces all information previously supplied. STMicroelectronics products are not authorized for use as critical components in life support devices or systems without express written approval of STMicroelectronics.

The ST logo is a registered trademark of STMicroelectronics
All other names are the property of their respective owners

© 2004 STMicroelectronics - All Rights Reserved
STMicroelectronics GROUP OF COMPANIES

Australia - Belgium - Brazil - Canada - China - Czech Republic - Finland - France - Germany - Hong Kong - India - Israel - Italy - Japan - Malaysia - Malta - Morocco - Singapore - Spain - Sweden - Switzerland - United Kingdom - United States.

<http://www.st.com>