
Features

- Current-controlled Output Current Source with 3 Input Channels
- Two Selectable Outputs for Grounded Laser Diodes
- Output Current per Write Channel: 350 mA
- Total Output Current: 500 mA
- 200 Ω Channel Input Resistance
- On-chip RF Oscillator
- Control of Two Different Swings by Use of Two External Resistors
- Oscillator Frequency Range from 200 MHz to 500 MHz
- Oscillator Swing: 100 mA
- Single 5 V Power Supply
- Common Enable/Disable Input
- TTL/CMOS Control Signals
- Small Pb-free QFN16 (4 mm \times 4 mm) or SSO16 Package

Applications

- DVD-ROM with CD-RW Capability
- DVD+RW with CD-RW Capability
- DVD-RW with CD-RW Capability
- Writable Optical Drives

Description

The ATR0808 is a laser diode driver for the operation of two different grounded laser diodes for DVD-RW/DVD+RW (650 nm) and CD-RW (780 nm). It includes three channels for three different optical power levels which are controlled by a separate IC. The read channel generates a continuous output level, whereas the channels 2 and 3 are provided as write channels with very fast switching speeds. Write current pulses are enabled when a low signal is applied to the NE pins. All channels are summed together and switched to one of the two IOUTA or IOUTB outputs by the select input SELA. Each write channel (channel 2 and 3) can contribute up to 350 mA to the total output current, up to 500 mA. The read channel can contribute up to 150 mA. Total gains of 100 (read channel), 250 (channel 2 and 3) are provided between each reference current input and the selected output. Although, the reference inputs are current inputs, voltage control is possible by using external resistors. An on-chip RF oscillator is provided to reduce laser mode hopping noise during read mode. Swing can be set independently for the two selectable outputs with two different resistors. Oscillation is enabled by a high signal at the ENOSC pin. Complete output current and oscillator switch-off is achieved by a low signal at the ENABLE input.



Three Channel Laser Driver with RF Oscillator and Two Outputs

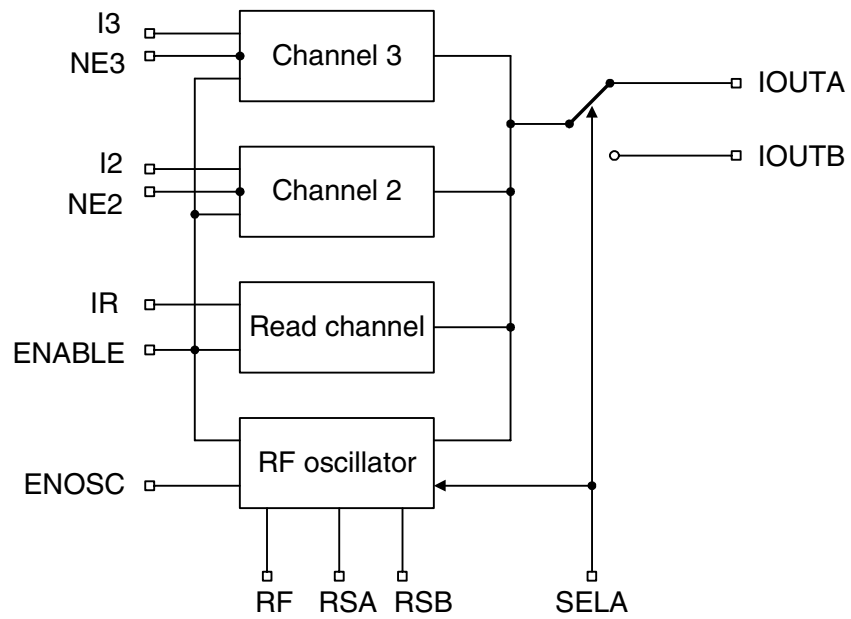
ATR0808

Summary

Rev. 4724ES-DVD-01/04

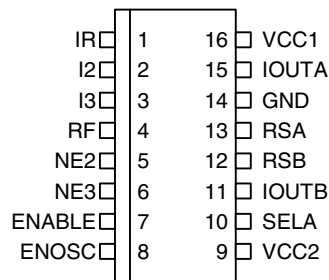


Figure 1. Block Diagram



Pin Configuration SSO16

Figure 2. Pinning SSO16

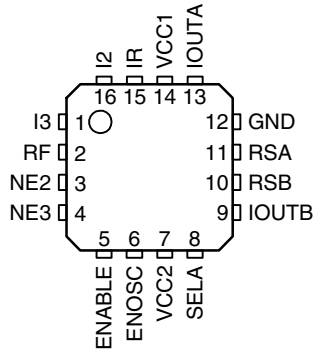


Pin Description

Pin	Symbol	Type	Function
1	IR	Analog	Input current, bias voltage approximately GND
2	I2	Analog	Input current, bias voltage approximately GND
3	I3	Analog	Input current, bias voltage approximately GND
4	RF	Analog	External resistor to GND sets frequency of oscillator
5	NE2	Digital	Digital control of channel 2 (low active)
6	NE3	Digital	Digital control of channel 3 (low active)
7	ENABLE	Digital	Enables output current (high active)
8	ENOSC	Digital	Enables RF oscillator (high active)
9	VCC2	Supply	+5 V power supply for IOU
10	SELA	Digital	High: selects IOUTA, RSA Low: selects IOUTB, RSB
11	IOUTB	Analog	Output current source B for laser diode
12	RSB	Analog	External resistor to GND sets swing of oscillator B
13	RSA	Analog	External resistor to GND sets swing of oscillator A
14	GND	Supply	Ground
15	IOUTA	Analog	Output current source A for laser diode
16	VCC1	Supply	+5 V power supply for IOU and circuit

Pin Configuration QFN16

Figure 3. Pinning QFN16



Pin Description

Pin	Symbol	Type	Function
1	I3	Analog	Input current, bias voltage approximately GND
2	RF	Analog	External resistor to GND sets frequency of oscillator
3	NE2	Digital	Digital control of channel 2 (low active)
4	NE3	Digital	Digital control of channel 3 (low active)
5	ENABLE	Digital	Enables output current (high active)
6	ENOSC	Digital	Enables RF oscillator (high active)
7	VCC2	Supply	+5 V power supply for IOUT
8	SELA	Digital	High: selects IOUTA, RSA Low: selects IOUSB, RSB
9	IOUSB	Analog	Output current source B for laser diode
10	RSB	Analog	External resistor to GND sets swing of oscillator B
11	RSA	Analog	External resistor to GND sets swing of oscillator A
12	GND	Supply	Ground
13	IOUTA	Analog	Output current source A for laser diode
14	VCC1	Supply	+5 V power supply for circuit
15	IR	Analog	Input current, bias voltage approximately GND
16	I2	Analog	Input current, bias voltage approximately GND
Paddle	GND	Supply	Ground

Absolute Maximum Ratings

Stresses beyond those listed under “Absolute Maximum Ratings” may cause permanent damage to the device. This is a stress rating only and functional operation of the device at these or any other conditions beyond those indicated in the operational sections of this specification is not implied. Exposure to absolute maximum rating conditions for extended periods may affect device reliability.

Parameters	Symbol	Value	Unit
Supply voltage	V_{CC}	-0.5 to +6.0	V
Input voltage at any input	V_{in}	-0.5 to $V_{CC} + 0.5$	V
Power dissipation	P_{max}	0.7 ⁽¹⁾ to 1 ⁽²⁾	W
Output voltage	V_{out}	-0.5 to $V_{CC} - 1$	V
Junction temperature	T_j	150	°C
Storage temperature	T_{stg}	-65 to +125	°C

- Notes: 1. $R_{thJA} \leq 115$ K/W at $T_{amb} = 70^\circ\text{C}$
 2. $R_{thJA} \leq 115$ K/W at $T_{amb} = 25^\circ\text{C}$

Thermal Resistance

Parameters	Symbol	Value	Unit
Junction ambient	R_{thJA}	115 ⁽¹⁾	K/W

- Note: 1. Measured with multi-layer test board (JEDEC standard)

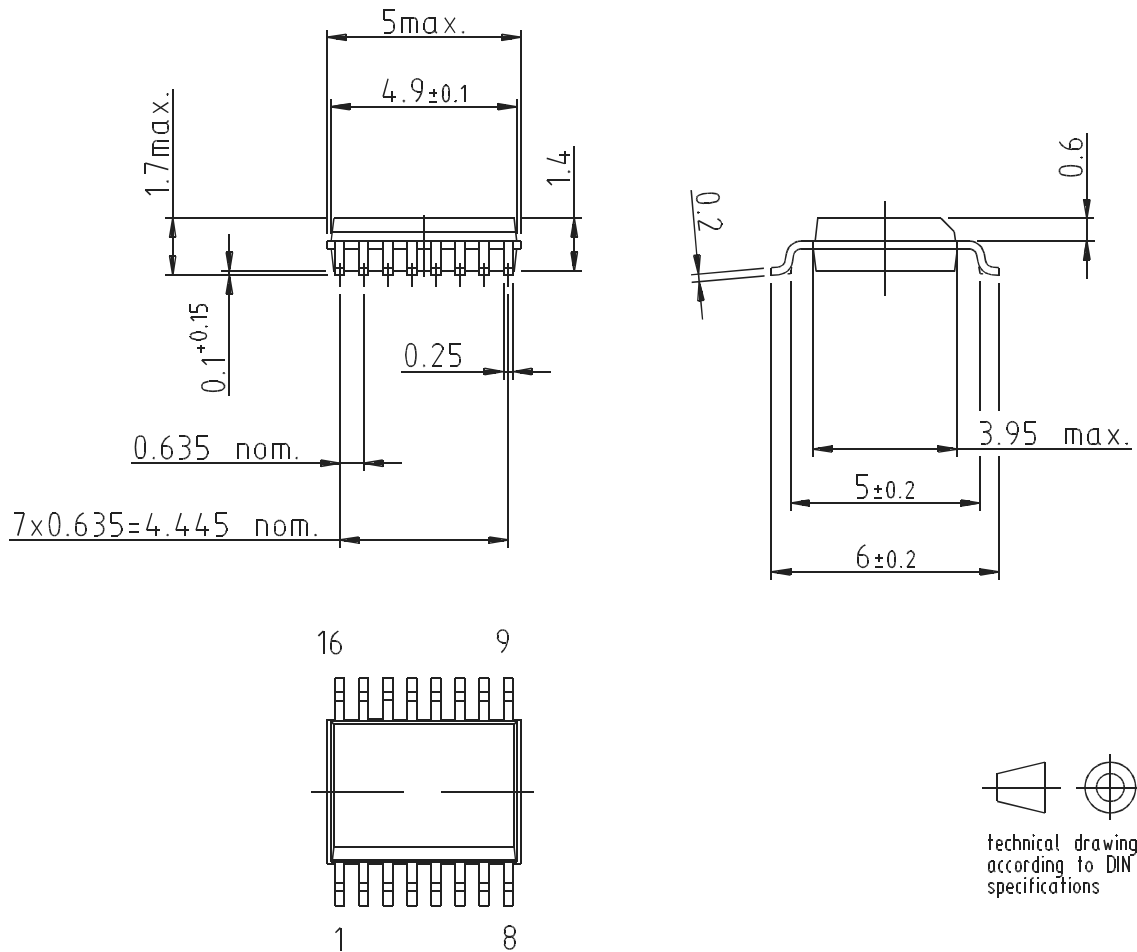
Recommended Operating Conditions

Parameters	Symbol	Value	Unit
Supply voltage	V_{CC}	4.5 to 5.5	V
Input current	I_{IR}, I_{I2}, I_{I3}	$I_{IR} < 2.0, I_{I2} = I_{I3} < 1.5$	mA
External resistor to GND to set oscillator frequency	RF	> 3	kΩ
External resistor to GND to set oscillator swing	RSA, RSB	> 1	kΩ
Operating temperature range	T_{amb}	0 to +70	°C

Ordering Information

Extended Type Number	Package	Remarks
ATR0808-TCQG	Pb-free SSO16	Taped and reeled
ATR0808-PEQG	Pb-free QFN16 (4 mm x 4 mm)	Taped and reeled

Package SSO16



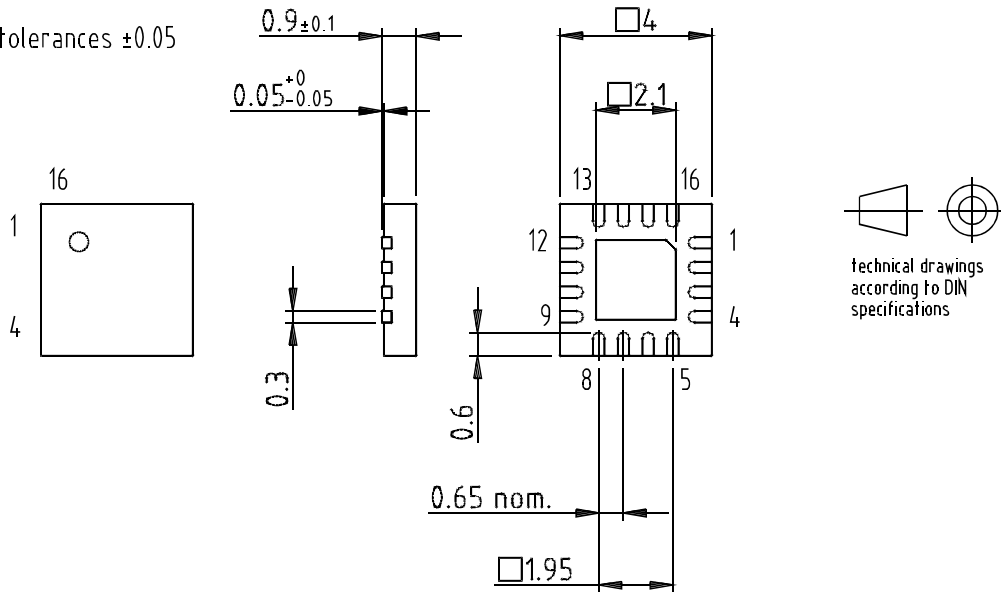
Drawing refers to following types: SSO16
 Package acc. JEDEC MO 137 AB

Drawing-No.: 6.543-5060.01-4
 Issue: 2; 05.02.99

Package QFN16 (4 mm x 4 mm)

Package: QFN 16 - 4x4
 Exposed pad 2.1x2.1
 (acc. JEDEC OUTLINE No. MO-220)
 Dimensions in mm

Not indicated tolerances ± 0.05



Drawing-No.: 6.543-5090.01-4
 Issue: 2; 24.01.03



Atmel Corporation

2325 Orchard Parkway
San Jose, CA 95131, USA
Tel: 1(408) 441-0311
Fax: 1(408) 487-2600

Regional Headquarters

Europe

Atmel Sarl
Route des Arsenalux 41
Case Postale 80
CH-1705 Fribourg
Switzerland
Tel: (41) 26-426-5555
Fax: (41) 26-426-5500

Asia

Room 1219
Chinachem Golden Plaza
77 Mody Road Tsimshatsui
East Kowloon
Hong Kong
Tel: (852) 2721-9778
Fax: (852) 2722-1369

Japan

9F, Tonetsu Shinkawa Bldg.
1-24-8 Shinkawa
Chuo-ku, Tokyo 104-0033
Japan
Tel: (81) 3-3523-3551
Fax: (81) 3-3523-7581

Atmel Operations

Memory

2325 Orchard Parkway
San Jose, CA 95131, USA
Tel: 1(408) 441-0311
Fax: 1(408) 436-4314

Microcontrollers

2325 Orchard Parkway
San Jose, CA 95131, USA
Tel: 1(408) 441-0311
Fax: 1(408) 436-4314

La Chantrerie
BP 70602
44306 Nantes Cedex 3, France
Tel: (33) 2-40-18-18-18
Fax: (33) 2-40-18-19-60

ASIC/ASSP/Smart Cards

Zone Industrielle
13106 Rousset Cedex, France
Tel: (33) 4-42-53-60-00
Fax: (33) 4-42-53-60-01

1150 East Cheyenne Mtn. Blvd.
Colorado Springs, CO 80906, USA
Tel: 1(719) 576-3300
Fax: 1(719) 540-1759

Scottish Enterprise Technology Park
Maxwell Building
East Kilbride G75 0QR, Scotland
Tel: (44) 1355-803-000
Fax: (44) 1355-242-743

RF/Automotive

Theresienstrasse 2
Postfach 3535
74025 Heilbronn, Germany
Tel: (49) 71-31-67-0
Fax: (49) 71-31-67-2340

1150 East Cheyenne Mtn. Blvd.
Colorado Springs, CO 80906, USA
Tel: 1(719) 576-3300
Fax: 1(719) 540-1759

Biometrics/Imaging/Hi-Rel MPU/ High Speed Converters/RF Datacom

Avenue de Rochepleine
BP 123
38521 Saint-Egreve Cedex, France
Tel: (33) 4-76-58-30-00
Fax: (33) 4-76-58-34-80

Literature Requests

www.atmel.com/literature

Disclaimer: Atmel Corporation makes no warranty for the use of its products, other than those expressly contained in the Company's standard warranty which is detailed in Atmel's Terms and Conditions located on the Company's web site. The Company assumes no responsibility for any errors which may appear in this document, reserves the right to change devices or specifications detailed herein at any time without notice, and does not make any commitment to update the information contained herein. No licenses to patents or other intellectual property of Atmel are granted by the Company in connection with the sale of Atmel products, expressly or by implication. Atmel's products are not authorized for use as critical components in life support devices or systems.

© Atmel Corporation 2004. All rights reserved.

Atmel® and combinations thereof are the registered trademarks of Atmel Corporation or its subsidiaries.

Other terms and product names may be the trademarks of others.



Printed on recycled paper.

4724ES-DVD-01/04