

Description

The GM66150 series of positive fixed and adjustable regulators is designed to provide up to 1.5A output with high current, high accuracy, and extremely low dropout voltage performance. These regulators feature 300 to 350mV (full load) dropout voltages, and very low ground current. Although designed for high current loads, these devices are also useful in lower current, extremely low dropout-critical systems, where their minimal dropout voltage and ground current values are important characteristics.

The GM66150 is fully protected against overcurrent, reversed input polarity (or reversed battery connection), reversed lead insertion, over-temperature operation, and transient voltage spikes (positive or negative).

Five pin fixed voltage versions feature logic level ON/OFF control and an error flag which signals whenever the output falls out of regulation.

On the GM66151 and GM66152, the ENABLE pin may be tied to V_{IN} if it is not required for ON/OFF control.

The GM66150 is available in 3-pin and 5-pin TO-220 and surface mount TO-263 packages.

Features

- ◆ Fixed and Adjustable Voltage Versions
- ◆ Output Current up to 1.5A
- ◆ Low Dropout Voltage 350mV @ 1.5A
- ◆ Low Ground Current
- ◆ Accurate 1% Guaranteed Tolerance
- ◆ Extremely Fast Transient Response
- ◆ Reverse-battery Protection
- ◆ "Load Dump" Protection
- ◆ Zero-Current shutdown mode(5-pin versions)
- ◆ Error flag signals output out-of-regulation (5-pin versions)

Application

- High Efficiency Linear Regulators
- Post Regulators for Switching Supplies
- High Efficiency "Green" Computer Systems
- Battery Powered Equipment
- Automotive Electronics

TYPICAL APPLICATION CIRCUITS

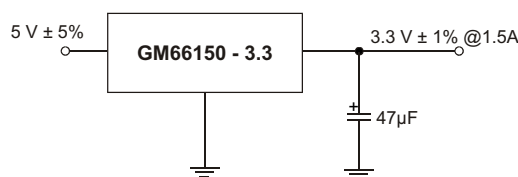

Figure 1. Fixed Voltage Version

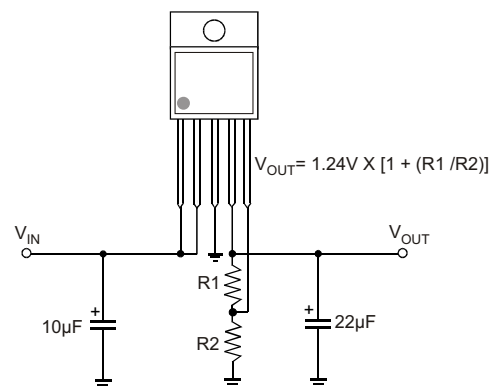
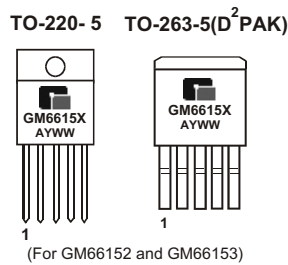
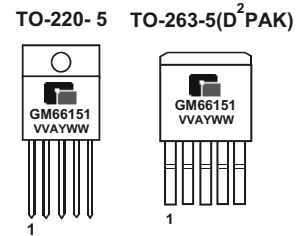
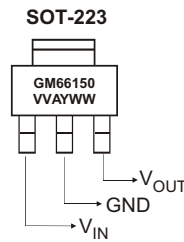

Figure 2. Adjustable Voltage Version

◆ MARKING INFORMATION & PIN CONFIGURATIONS (TOP VIEW)



V V, VVV = Output Voltage
(33=3.3V, 120=12V)
A = Assembly Location
Y = Year
W W = Weekly

Pinout On all devices, the Tab is grounded.

GM66150/ Three Terminal

Pin 1 = Input, 2 = Ground, 3 = Output

GM66151/ Five Terminal (Fixed Voltage Devices)

Pin 1 = Enable, 2 = Input, 3 = Ground,
4 = Output, 5 = Flag

GM66152/ Adjustable with ON/ OFF Control

Pin 1 = Enable, 2 = Input, 3 = Ground,
4 = Output, 5 = Adjust

GM66153/ Adjustable with Flag

Pin 1 = Flag, 2 = Input, 3 = Ground,
4 = Output, 5 = Adjust

◆ ORDERING INFORMATION

Ordering Number	Output Voltage	Package	Shipping
GM66150			
GM66150-1.5TA3T	1.5V	TO-263-2	50 Units/ Tube
GM66150-1.5TA3R	1.5V	TO-263-2	800 Units/ Tape & Reel
GM66150-1.5TB3T	1.5V	TO-220	50 Units/ Tube
GM66150-1.8TA3T	1.8V	TO-263-2	50 Units/ Tube
GM66150-1.8TA3R	1.8V	TO-263-2	800 Units/ Tape & Reel
GM66150-1.8TB3T	1.8V	TO-220	50 Units/ Tube
GM66150-2.5TA3T	2.5V	TO-263-2	50 Units/ Tube
GM66150-2.5TA3R	2.5V	TO-263-2	800 Units/ Tape & Reel
GM66150-2.5TB3T	2.5V	TO-220	50 Units/ Tube
GM66150-2.5TC3T	2.5V	TO-252	80 Units/ Tube
GM66150-2.5TC3R	2.5V	TO-252	2,500 Units/ Tape & Reel
GM66150-3.0TA3T	3.0V	TO-263-2	50 Units/ Tube
GM66150-3.0TA3R	3.0V	TO-263-2	800 Units/ Tape & Reel
GM66150-3.0TB3T	3.0V	TO-220	50 Units/ Tube
GM66150-3.0ST3T	3.0V	TO-223	80 Units/ Tube
GM66150-3.0ST3R	3.0V	TO-223	2,500 Units/ Tape & Reel
GM66150-3.0TC3T	3.0V	TO-252	80 Units/ Tube
GM66150-3.0TC3R	3.0V	TO-252	2,500 Units/ Tape & Reel

◆ ORDERING INFORMATION

Ordering Number	Output Voltage	Package	Shipping
GM66150			
GM66150-3.3TA3T	3.3V	TO-263-2	50 Units/ Tube
GM66150-3.3TA3R	3.3V	TO-263-2	800 Units/ Tape & Reel
GM66150-3.3TB3T	3.3V	TO-220	50 Units/ Tube
GM66150-5.0TA3T	5.0V	TO-263-2	50 Units/ Tube
GM66150-5.0TA3R	5.0V	TO-263-2	800 Units/ Tape & Reel
GM66150-5.0TB3T	5.0V	TO-220	50 Units/ Tube
GM66150-12TA3T	12V	TO-263-2	50 Units/ Tube
GM66150-12TA3R	12V	TO-263-2	800 Units/ Tape & Reel
GM66150-12TB3T	12V	TO-220	50 Units/ Tube
GM66151			
GM66151-1.5TA5T	1.5V	TO-263-5	50 Units/ Tube
GM66151-1.5TA5R	1.5V	TO-263-5	800 Units/ Tape & Reel
GM66151-1.5TB5T	1.5V	TO-220-5	50 Units/ Tube
GM66151-1.8TA5T	1.8V	TO-263-5	50 Units/ Tube
GM66151-1.8TA5R	1.8V	TO-263-5	800 Units/ Tape & Reel
GM66151-1.8TB5T	1.8V	TO-220-5	50 Units/ Tube
GM66151-2.5TA5T	2.5V	TO-263-5	50 Units/ Tube
GM66151-2.5TA5R	2.5V	TO-263-5	800 Units/ Tape & Reel
GM66151-2.5TB5T	2.5V	TO-220-5	50 Units/ Tube
GM66151-3.0TA5T	3.0V	TO-263-5	50 Units/ Tube
GM66151-3.0TA5R	3.0V	TO-263-5	800 Units/ Tape & Reel
GM66151-3.0TB5T	3.0V	TO-220-5	50 Units/ Tube
GM66151-3.3TA5T	3.3V	TO-263-5	50 Units/ Tube
GM66151-3.3TA5R	3.3V	TO-263-5	800 Units/ Tape & Reel
GM66151-3.3TB5T	3.3V	TO-220-5	50 Units/ Tube
GM66151-5.0TA5T	5.0V	TO-263-5	50 Units/ Tube
GM66151-5.0TA5R	5.0V	TO-263-5	800 Units/ Tape & Reel
GM66151-5.0TB5T	5.0V	TO-220-5	50 Units/ Tube
GM66151-12TA5T	12V	TO-263-5	50 Units/ Tube
GM66151-12TA5R	12V	TO-263-5	800 Units/ Tape & Reel
GM66151-12TB5T	12V	TO-220-5	50 Units/ Tube

* For detail Ordering Number identification, please see last page.

◆ ORDERING INFORMATION

Ordering Number	Output Voltage	Package	Shipping
GM66152			
GM66152TA5T	Adj	TO-263-5	50 Units/ Tube
GM66152TA5R	Adj	TO-263-5	800 Units/ Tape & Reel
GM66152TB5T	Adj	TO-220-5	50 Units/ Tube
GM66153			
GM66153TA5T	Adj	TO-263-5	50 Units/ Tube
GM66153TA5R	Adj	TO-263-5	800 Units/ Tape & Reel
GM66153TB5T	Adj	TO-220-5	50 Units/ Tube

* For detail Ordering Number identification, please see last page.

◆ ABSOLUTE MAXIMUM RATINGS

PARAMETER	SYMBOL	VALUE	UNIT
Power Dissipation	P_D	Internally limited	W
Input Supply Voltage (Note 1)	V_{IN}	-20 to +60	V
Lead Temperature (Soldering, 5 sec)	T_{LEAD}	260	°C
Storage Temperature Range	T_{STG}	-65 to +150	°C

◆ OPERATING RATINGS

PARAMETER	SYMBOL	VALUE	UNIT
Maximum Operating Input Voltage	V_{IN}	26	V
Operating junction Temperature Range	T_J	-40 to +125	°C

◆ BLOCK DIAGRAM

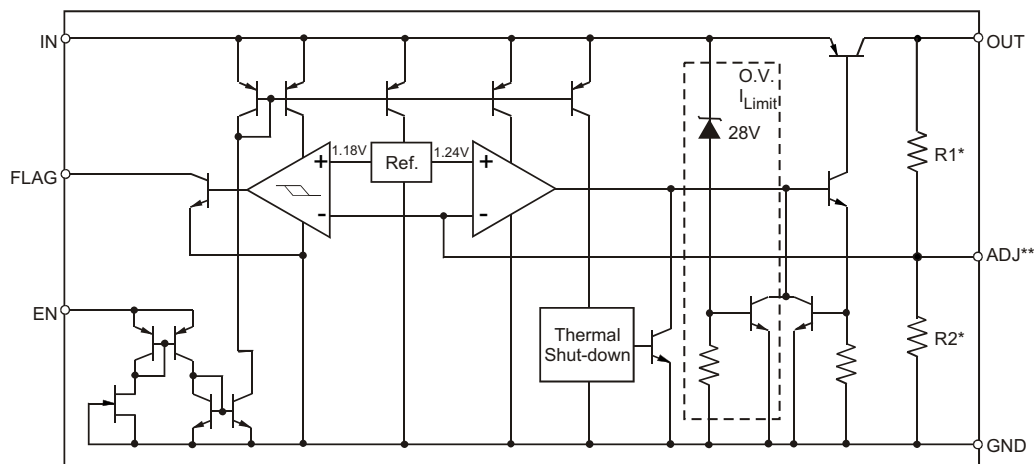

* Feedback network in fixed version only
 ** Adjustable version only

◆ ELECTRICAL CHARACTERISTICS ($T_A = 25^\circ\text{C}$ unless otherwise noted)

Unless otherwise specified: $T_J = 25^\circ\text{C}$; **Bold** values are guaranteed across the operating temperature range.
Adjustable versions are programmed to 5.0V.

Parameter	Conditions	Min	Typ	Max	Unit
Output Voltage (Note2)	$I_O = 10\text{ mA}$	-1		1	%
	$10\text{mA} \leq I_O \leq I_{FL}, (V_{OUT} + 1\text{V}) \leq V_{IN} \leq 26\text{V}$	-2		2	%
Line Regulation	$I_O = 10\text{mA}, (V_{OUT} + 1\text{V}) \leq V_{IN} \leq 26\text{V}$		0.06	0.5	%
Load Regulation (Note 2, 6)	$V_{IN} = V_{OUT} + 5\text{V}, 10\text{mA} \leq I_{OUT} \leq I_{FL}$		0.20	1.0	%
Output Voltage change with Temperature Coef. (Note 6)	V_{OUT}/T		20	100	ppm/ $^\circ\text{C}$
Dropout Voltage	$V_{OUT} - 1\%$ (Note 3) $I_O = 100\text{mA}$ $I_O = 750\text{mA}$ $I_O = 1.5\text{A}$		80	200	mV
			220	600	
			350		
Ground Current	$I_O = 750\text{mA}, V_{IN} = V_{OUT} + 1\text{V}$ $I_O = 1.5\text{A}$		8 22	20	mA
Ground Pin Current at Dropout I_{GNDDO}	$V_{IN} = 0.5\text{V}$ less than specified $V_{OUT}, I_{OUT} = 10\text{mA}$		2.0		mA
Current Limit	$V_{OUT} = 0\text{V}$ (Note 4)		2.1	3.5	A
Output Noise Voltage e_n , (10Hz to 100Hz) $I_O = 100\text{mA}$	$C_L = 10\mu\text{F}$ $C_L = 33\mu\text{F}$		400		μV (rms)
			260		
Reference GM66152					
Reference Voltage		1.228	1.240	1.252	V
		1.215		1.265	V
Reference Voltage	(Note 8)	1.203		1.277	V
Adjust Pin Bias Current			40	80 120	nA
Reference Voltage change with Temperature Coef.	(Note 7)		20		ppm/ $^\circ\text{C}$
Adjust Pin Bias Current change with Temperature			0.1		nA/ $^\circ\text{C}$
Flag Output (Error Comparator) GM66151/ GM66153					
Output Leakage Current	$V_{OH} = 26\text{V}$		0.01	1 2	μA
Output Low Voltage	Device set for 5V, $V_{IN} = 4.5\text{V}$ $I_{OL} = 250\mu\text{A}$		220	300 400	mV
Upper Threshold Voltage	Device set for 5V(Note 9)	40 25	60		mV
Lower Threshold Voltage	Device set for 5V(Note 9)		75	95 140	mV
Hysteresis	Device set for 5V(Note 9)		15		mV
Enable Input GM66151 / GM66152					
Input Logic Voltage Low (OFF) High (ON)		2.4		0.8	V
Enable Pin Input Current	$V_{EN} = 26\text{V}$		100	600 750	μA
	$V_{EN} = 0.8\text{V}$			2.5 5.0	μA
Regulator Output Current In Shutdown	(Note10)		10	500	μA

◆ ELECTRICAL CHARACTERISTICS (continued)

- Note 1:** Maximum positive supply voltage of 60V must be of limited duration (<100msec) and duty cycle ($\leq 1\%$). The maximum continuous supply voltage is 26V.
- Note 2:** Full Load current (I_{FL}) is defined as 1.5A for the GM66150 series.
- Note 3:** Dropout voltage is defined as the input-to-output differential when the output voltage drops to 99% of its nominal value with $V_{OUT} + 1V$ applied to V_{IN} .
- Note 4:** $V_{IN} = V_{OUT} (\text{nominal}) + 1V$. For example, use $V_{IN} = 4.3V$ for a 3.3V regulator or use 6V for a 5V regulator. Employ pulse-testing procedures to minimize temperature rise.
- Note 5:** Ground pin current is the regulator quiescent current. The total current drawn from the source is the sum of the load current plus the ground pin current.
- Note 6:** Output voltage temperature coefficient is defined as the worst case voltage change divided by the total temperature range.
- Note 7:** Thermal regulation is defined as the change in output voltage at a time T after a change in power dissipation is applied, excluding load or line regulation effects. Specifications are for a 200mA load pulse at $V_{IN} = 20V$ (a 4W pulse) for T = 10ms.
- Note 8:** $V_{REF} \leq V_{OUT} \leq (V_{IN} - 1V)$, $2.3V \leq V_{IN} \leq 26V$, $10mA < I_L \leq I_{FL}$, $T_J \leq T_{JMAX}$.
- Note 9:** Comparator thresholds are expressed in terms of a voltage differential at the Adjust terminal below the nominal reference voltage measured at 6V input. To express these thresholds in terms of output voltage change, multiply by the error amplifier gain $= V_{OUT} / V_{REF} = (R1 + R2) / R2$. For example, at a programmed output voltage of 5V, the Error output is guaranteed to go low when the output drops by $95 mV \times 5V / 1.240 V = 384 mV$. Thresholds remain constant as a percent of V_{OUT} as V_{OUT} is varied, with the dropout warning occurring at typically 5% below nominal, 7.7% guaranteed.
- Note 10:** $V_{EN} \leq 0.8V$ and $V_{IN} \leq 26V$, $V_{OUT} = 0$.
- Note 11:** When used in dual supply systems where the regulator load is returned to a negative supply, the output voltage must be diode clamped to ground.

◆ TYPICAL CHARACTERISTICS GM66150

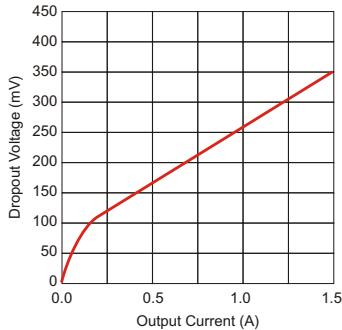

Figure 1. GM66150 Dropout Voltage vs. Output Current

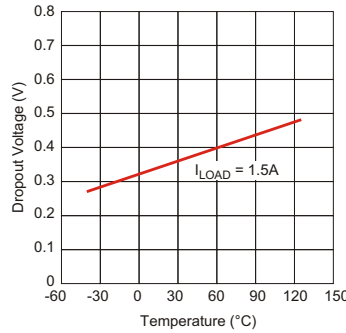

Figure 2. GM66150 Dropout Voltage vs. Temperature

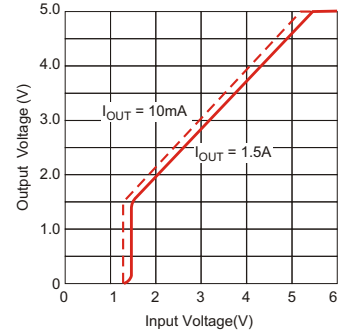

Figure 3. GM66102-5.0 Dropout Characteristics

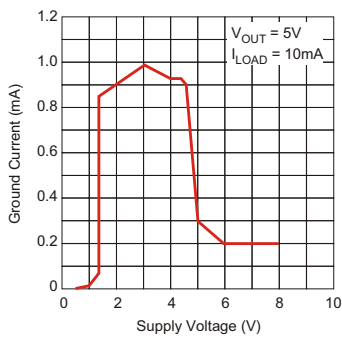

Figure 4. GM66150 Ground Current vs. Supply Voltage

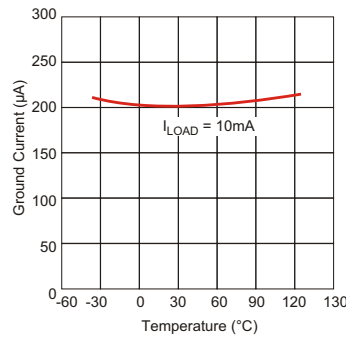

Figure 5. GM66150 Ground Current vs. Temperature

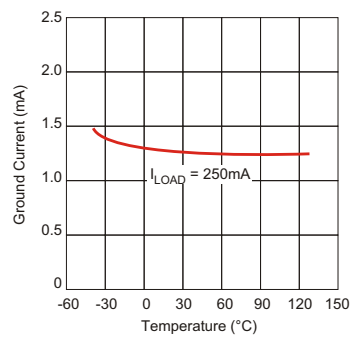

Figure 6. GM66150 Ground Current vs. Temperature

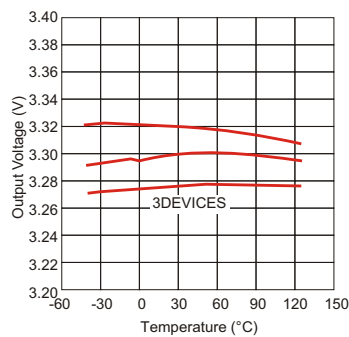

Figure 7. GM66150-3.3 Output Voltage vs. Temperature

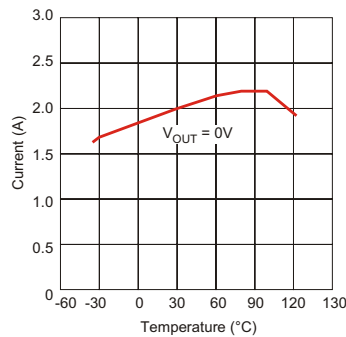

Figure 8. GM66150-3.3 Short Circuit Current vs. Temperature

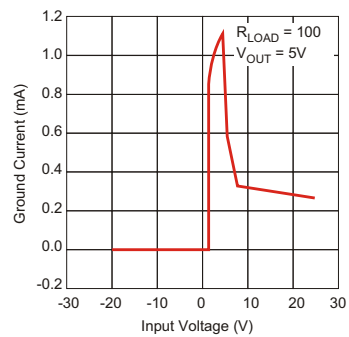

Figure 9. GM66150 Ground Current vs. Input Voltage

◆ APPLICATION INFORMATION

The GM66150 series is high performance with low-dropout voltage regulators, suitable for all moderate to high-current voltage regulator applications. Their 350mV dropout voltage at full load makes them especially valuable in battery powered systems and as high efficiency noise filters in "post-regulator" applications. Unlike older NPN-pass transistor designs, for which where the minimum dropout voltage is limited by the base-emitter voltage drop and collector-emitter saturation voltage, dropout performance of the PNP output of these devices is limited merely by the low V_{CE} saturation voltage. A trade-off for the low dropout voltage is a varying base drive requirement. But, Gamma's PNP process reduces this drive requirement to merely 1% of the load current.

The GM66150 series of regulators is fully protected from damage due to fault conditions. Current limiting is provided. This limiting is linear, and output current under overload conditions is constant. Thermal shutdown disables the device when the die temperature exceeds the 125°C maximum safe operating temperature. Transient protection allows device (and load) survival even when the input voltage spikes between -20V and +60V. When the input voltage exceeds about 35V to 40V, the overvoltage sensor temporarily disables the regulator. The output structure of these regulators allows voltages in excess of the desired output voltage to be applied without reverse current flow. GM66151 and GM66152 versions offer a logic level ON/OFF control: when disabled, the devices draw nearly zero current.

An additional feature of this regulator family is a common pinout: a design's current requirement may change up or down yet use the same board layout, as all of these regulators have identical pinouts.

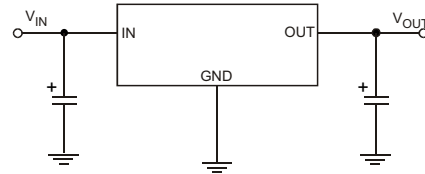

Figure 10. Linear regulators require only two capacitors for operation.

Thermal Design

Linear regulators are simple to use. The most complicated design parameters to consider are thermal characteristics. Thermal design requires the following application-specific parameters:

- Maximum ambient temperature, T_A
- Output Current, I_{OUT}
- Output Voltage, V_{OUT}
- Input Voltage, V_{IN}

First, we calculate the power dissipation of the regulator from these numbers and the device parameters from this formula:

$$P_D = I_{OUT} (1.01V_{IN} - V_{OUT})$$

where the ground current is approximated by 1% of I_{OUT} .

Then the heat sink thermal resistance is determined with this formula:

$$R_{SA} = \frac{T_{J(MAX)} - T_A}{P_D} (R_{JC} + R_{CS})$$

where $T_{J(MAX)} \leq 125^\circ\text{C}$ and R_{CS} is between 0 and 2°C/W. The heat sink may be significantly reduced in applications where the minimum input voltage is known and is large compared with the dropout voltage. Use a series input resistor to drop excessive voltage and distribute the heat between this resistor and the regulator. The low dropout properties of Gamma PNP regulators allow very significant reductions in regulator power dissipation and the associated heat sink without compromising performance. When this technique is employed, a capacitor of at least 0.1µF is needed directly between the input and regulator ground.

Capacitor Requirements

For stability and minimum output noise, a capacitor on the regulator output is necessary. The value of this capacitor is dependent upon the output current; lower currents allow smaller capacitors. GM66150 regulators are stable with the minimum capacitor value of 10µF at full load. This capacitor needs not be an expensive low ESR type: aluminum electrolytics are adequate. In fact, extremely low ESR capacitors may contribute to instability. Tantalum capacitors are recommended for systems where fast load transient response is important. Where the regulator is powered from a source with a high AC impedance, a 0.1µF capacitor connected between Input and GND is recommended. This capacitor should have good characteristics to above 250kHz.

Minimum Load Current

The GM66150 regulators are specified between finite loads. If the output current is too small, leakage currents dominate and the output voltage rises. The 5mA minimum load current swamps any expected leakage current across the operating temperature range.

Adjustable Regulator Design

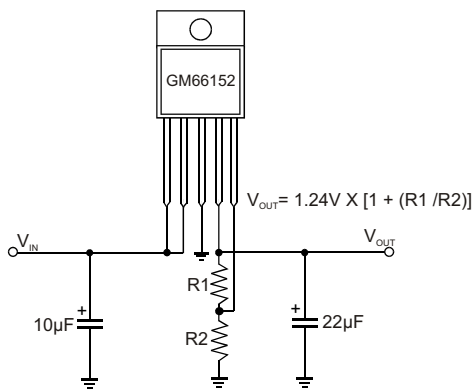

Figure 11. Adjustable Regulator with Resistor

The adjustable regulator versions, GM66152 and GM66153, allow programming the output voltage anywhere between 1.25V and the 26V maximum operating rating of the family. Two resistors are used. Resistors can be quite large, up to 1M , because of the very high input impedance and low bias current of the sense comparator: The resistor values are calculated by:

$$R1 = R2 \left(\frac{V_{OUT}}{1.240} - 1 \right)$$

where V_O is the desired output voltage. Figure 11 shows component definition. Applications with widely varying load currents may scale the resistors to draw the minimum load current required for proper operation (see above).

Error Flag

GM66151 and GM66153 versions feature an Error Flag, which looks at the output voltage and signals an error condition when this voltage drops 5% below its expected value. The error flag is an open-collector output that pulls low under fault conditions. It may sink 10mA. Low output voltage signifies a number of possible problems, including an overcurrent fault (the device is in current limit) and low input voltage. The flag output is inoperative during overtemperature shutdown conditions.

Enable Input

GM66151 and GM66152 versions feature an enable (EN) input that allows ON/OFF control of the device. Special design allows "zero" current drain when the device is disabled -only microamperes of leakage current flows. The EN input has TTL/CMOS compatible thresholds for simple interfacing with logic, or may be directly tied to $\leq 30V$. Enabling the regulator requires approximately 20µA of current.

◆ TO-220PACKAGE OUTLINE DIMENSIONS

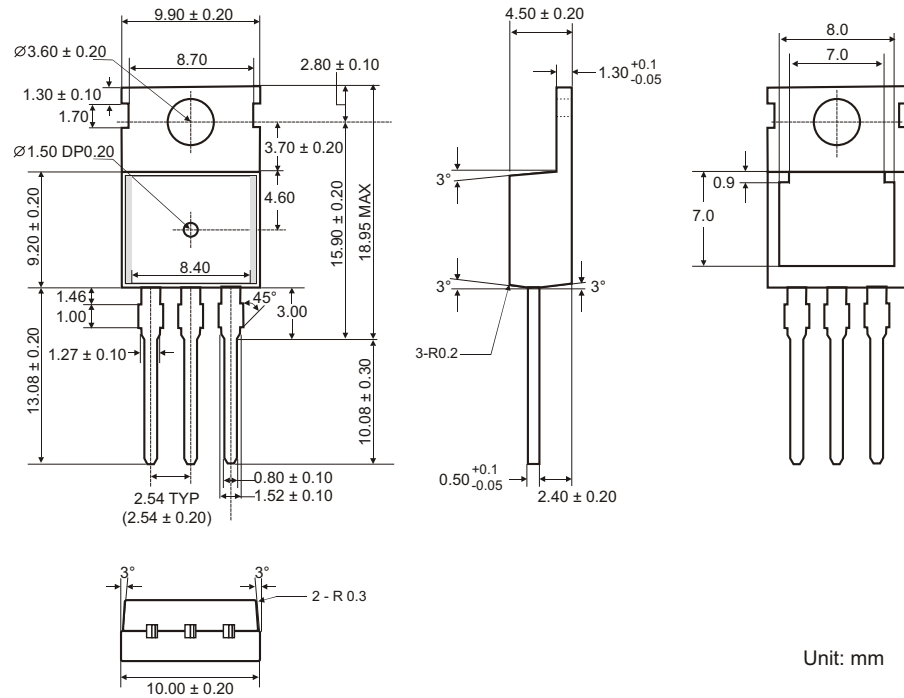

◆ TO-220-5 PACKAGE OUTLINE DIMENSIONS

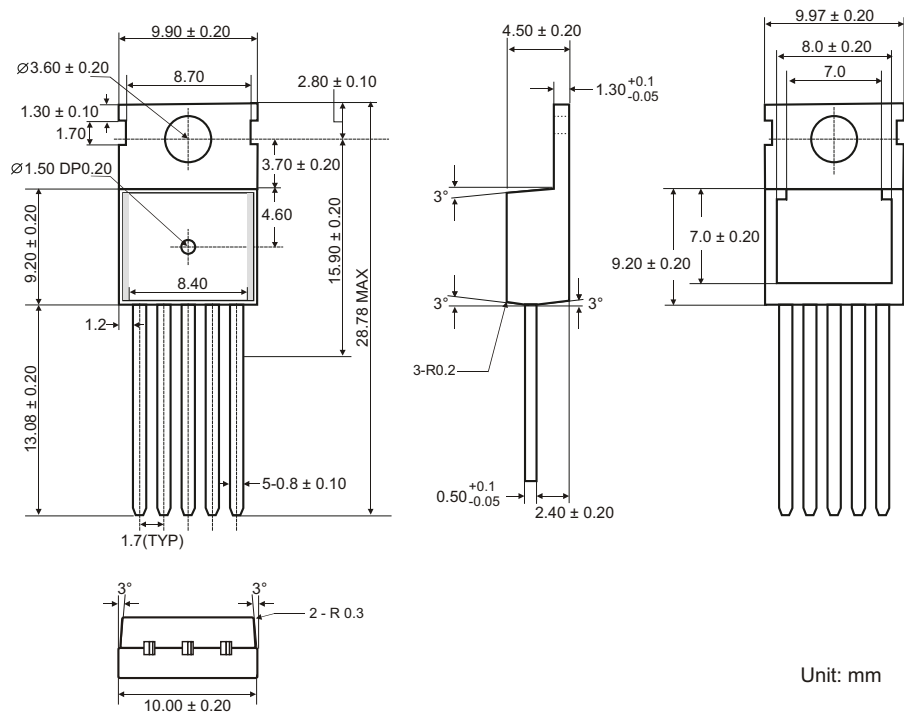

◆ TO-263-5 PACKAGE OUTLINE DIMENSIONS

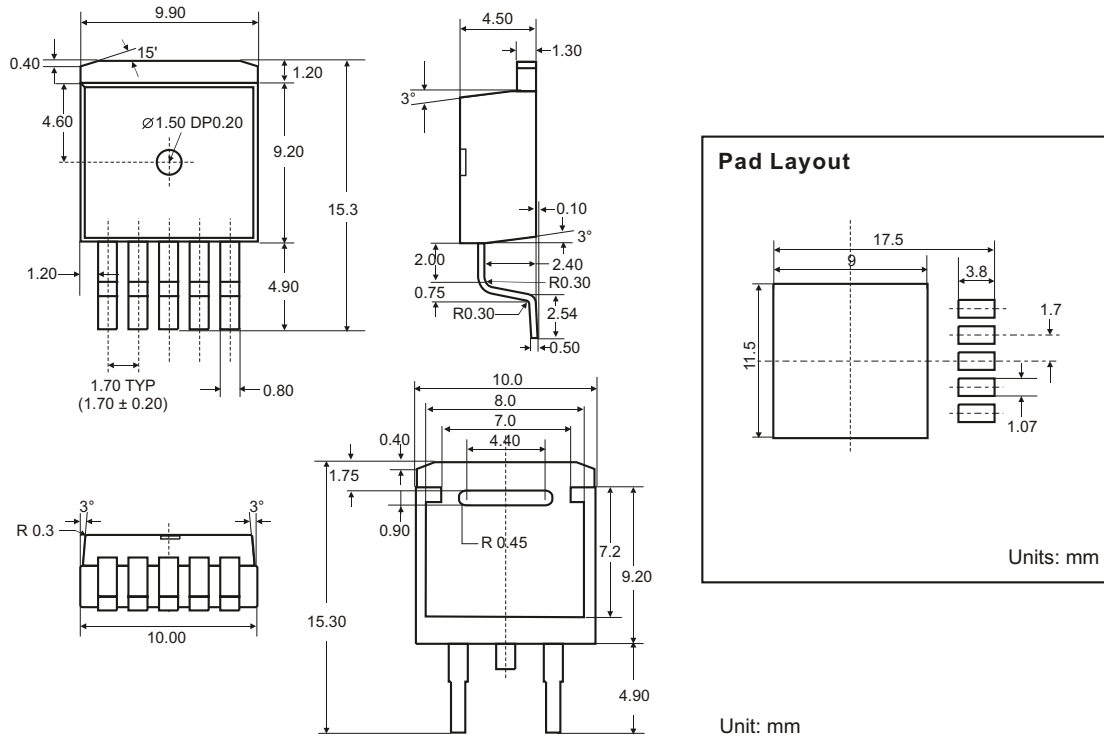

Unit: mm

◆ TO-252 PACKAGE OUTLINE DIMENSIONS

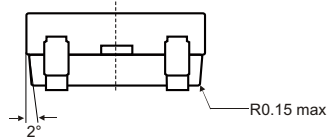
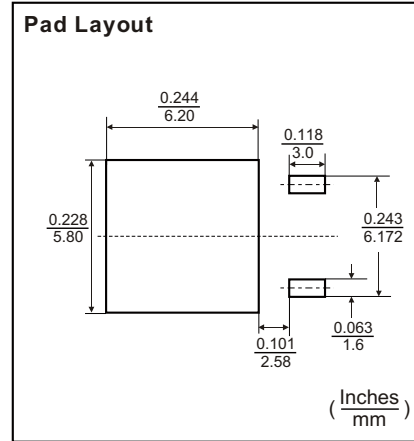
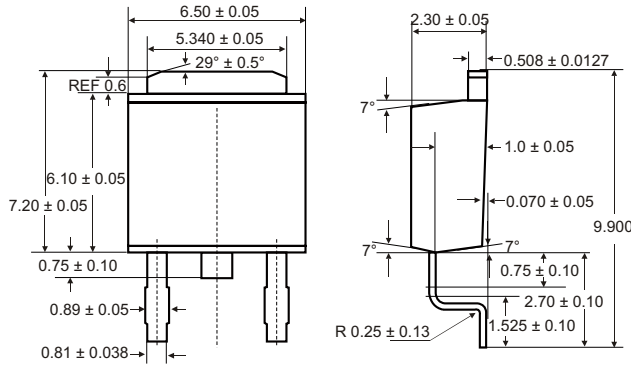

Unit: mm

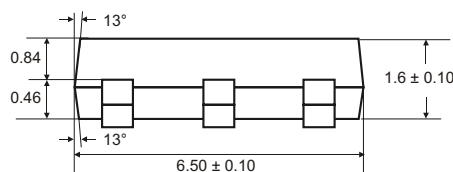
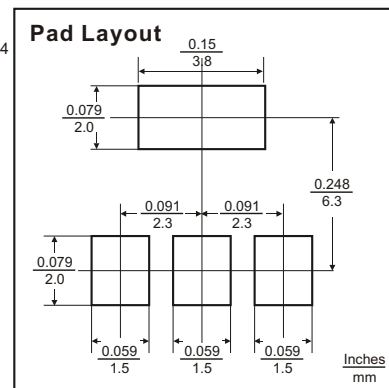
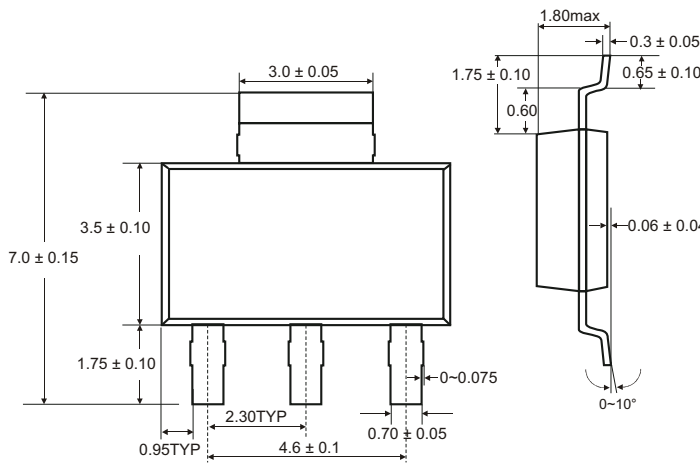

◆ SOT-223 PACKAGE OUTLINE DIMENSIONS

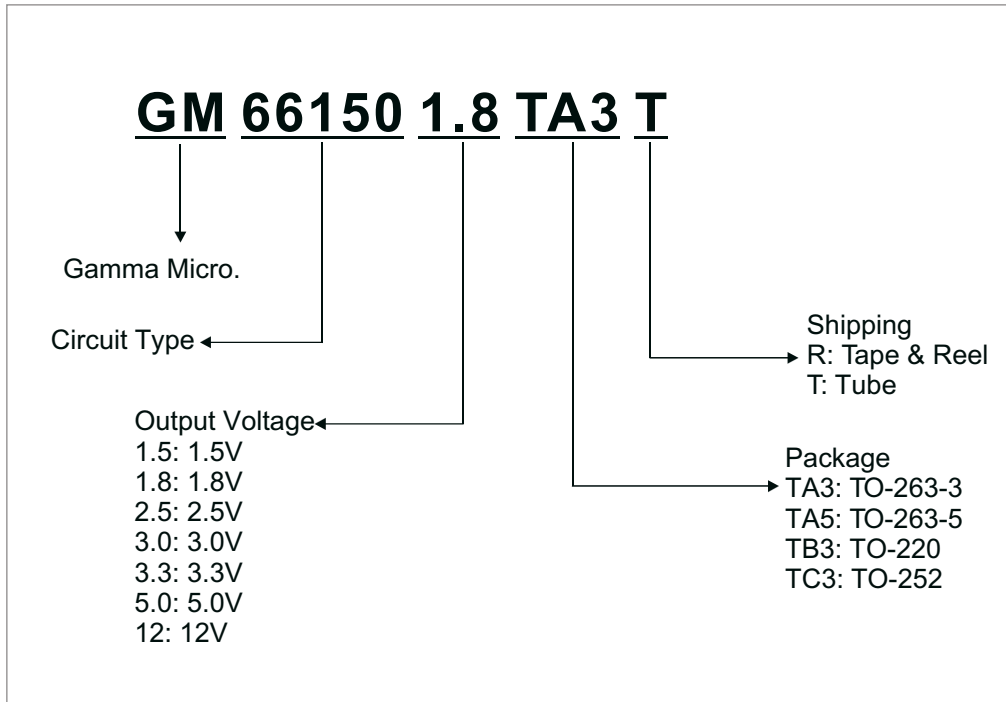

Unit: mm

◆ ORDERING NUMBER



GAMMA Micro, , and  are registered trademarks of GAMMA MICROELECTRONICS INC. GAMMA reserves the right to make changes without further notice to any products herein. Information provided herein is alleged to be exact and consistent and this publication surpasses and replaces all information previously supplied.

GAMMA makes no warranty the suitability of its products for any particular purpose, nor does GAMMA assume any liability arising out of the application or use of any product or circuit, and specifically disclaims any and all liability including without limitation special, consequential or incidental damages.

GAMMA products are not authorized for using as critical components in life support devices or systems without prior written approval from GAMMA MICROELECTRONICS INC.
