

HYS64T32000HM-[3S/3.7/5]-A  
HYS64T64020HM-[3S/3.7/5]-A

*214-Pin Micro-DIMM-DDR2-SDRAM Modules*  
*MDIMM*  
*DDR2 SDRAM*  
*RoHS Compliant*

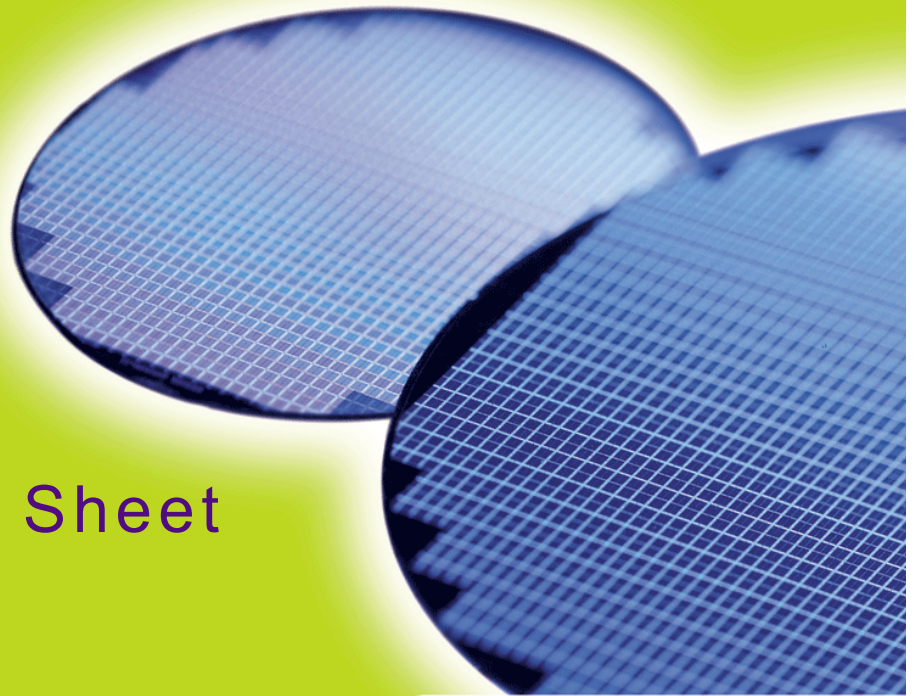

Internet Data Sheet

*Rev. 1.11*

HYS64T[32/64]0[0/2]0HM-[3S/3.7/5]-A  
Micro-DIMM DDR2 SDRAM Modules

<b>HYS64T32000HM-[3S/3.7/5]-A, HYS64T64020HM-[3S/3.7/5]-A</b>	
<b>Revision History: 2006-11, Rev. 1.11</b>	
<b>Page</b>	<b>Subjects (major changes since last revision)</b>
All	Qimonda update
All	Adapted internet edition
<b>Previous Revision: 2005-10, Rev. 1.1</b>	
All	Added -3S
<b>Previous Revision: 2004-10, 1.0</b>	

**We Listen to Your Comments**

Any information within this document that you feel is wrong, unclear or missing at all?

Your feedback will help us to continuously improve the quality of this document.

Please send your proposal (including a reference to this document) to:

[techdoc@qimonda.com](mailto:techdoc@qimonda.com)



# 1 Overview

This chapter gives an overview of the 1.8 V 214-Pin Micro-DIMM-DDR2-SDRAM Modules product family and describes its main characteristics.

## 1.1 Features

- 214-Pin PC2-5300, PC2-4200 and PC2-3200 DDR2 SDRAM memory modules for use as main memory when installed in systems such as mobile personal computers.
- 32M × 64 and 64M × 64 module organization, and 32M × 16 chip organization
- Standard Double-Data-Rate-Two Synchronous DRAMs (DDR2 SDRAM) with a single + 1.8 V (± 0.1 V) power supply
- 256MB and 512MB modules built with 512Mb DDR2 SDRAMs in P-TFBGA-84 chipsize packages
- Programmable CAS Latencies (3, 4 and 5), Burst Length (8 & 4) and Burst Type
- Burst Refresh, Distributed Refresh and Self Refresh
- All inputs and outputs SSTL\_1.8 compatible
- Off-Chip Driver Impedance Adjustment (OCD) and On-Die Termination (ODT)
- Serial Presence Detect with E<sup>2</sup>PROM
- MDIMM Dimensions (nominal): 30 mm high, 54.0 mm wide
- Based on standard reference layouts Raw Cards: “A” and “B”
- 2-piece type Mezzanine Socket with 0,4 mm contact centers
- RoHS Compliant Products<sup>1)</sup>

**TABLE 1**  
Performance Table

Product Type Speed Code		-3S	-3.7	-5	Unit	
Speed Grade		PC2-5300 5-5-5	PC2-4200 4-4-4	PC2-3200 3-3-3	—	
Max. Clock Frequency	@CL5	$f_{CK5}$	333	266	200	MHz
	@CL4	$f_{CK4}$	266	266	200	MHz
	@CL3	$f_{CK3}$	200	200	200	MHz
Min. RAS-CAS-Delay		$t_{RCD}$	15	15	15	ns
Min. Row Precharge Time		$t_{RP}$	15	15	15	ns
Min. Row Active Time		$t_{RAS}$	45	45	40	ns
Min. Row Cycle Time		$t_{RC}$	60	60	55	ns

1) RoHS Compliant Product: Restriction of the use of certain hazardous substances (RoHS) in electrical and electronic equipment as defined in the directive 2002/95/EC issued by the European Parliament and of the Council of 27 January 2003. These substances include mercury, lead, cadmium, hexavalent chromium, polybrominated biphenyls and polybrominated biphenyl ethers.



HYS64T[32/64]0[0/2]0HM-[3S/3.7/5]-A  
Micro-DIMM DDR2 SDRAM Modules

## 1.2 Description

The QIMONDA HYS64T[32/64]0[0/2]0HM-[3S/3.7/5]-A module family are Unbuffered Micro-DIMM modules "MDIMMs" with 30 mm height based on DDR2 technology. DIMMs are available as non-ECC modules in 32M × 64 (256 MB) and 64M × 64 (512 MB) organization and density, intended for mounting into 214-pin mezzanine connector sockets.

The memory array is designed with 512-Mbit Double-Data-Rate-Two (DDR2) Synchronous DRAMs. Decoupling

capacitors are mounted on the PCB board. The DIMMs feature serial presence detect based on a serial E<sup>2</sup>PROM device using the 2-pin I<sup>2</sup>C protocol. The first 128 bytes are programmed with configuration data and are write protected; the second 128 bytes are available to the customer.



**TABLE 2**  
Ordering Information for RoHS Compliant Products

Product Type <sup>1)</sup>	Compliance Code <sup>2)</sup>	Description	SDRAM Technology
<b>PC2-5300</b>			
HYS64T32000HM-3S-A	256MB 1R×16 PC2-5300M-555-12-B1	1 rank, Non-ECC	512 Mbit (×16)
HYS64T64020HM-3S-A	512MB 2R×16 PC2-5300M-555-12-A1	2 ranks, Non-ECC	512 Mbit (×16)
<b>PC2-4200</b>			
HYS64T32000HM-3.7-A	256MB 1R×16 PC2-4200M-444-12-B1	1 rank, Non-ECC	512 Mbit (×16)
HYS64T64020HM-3.7-A	512MB 2R×16 PC2-4200M-444-12-A1	2 ranks, Non-ECC	512 Mbit (×16)
<b>PC2-3200</b>			
HYS64T32000HM-5-A	256MB 1R×16 PC2-3200M-333-12-B1	1 rank, Non-ECC	512 Mbit (×16)
HYS64T64020HM-5-A	512MB 2R×16 PC2-3200M-333-12-A1	2 ranks, Non-ECC	512 Mbit (×16)

- 1) All Product Type numbers end with a place code, designating the silicon die revision. Example: HYS64T32000HM-3.7-A, indicating Rev. "A" dies are used for DDR2 SDRAM components. For all QIMONDA DDR2 module and component nomenclature see **Chapter 6** of this data sheet.
- 2) The Compliance Code is printed on the module label and describes the speed grade, for example "PC2-4200M-444-12-B1", where 4200M means Unbuffered Micro-DIMM modules with 4.26 GB/sec Module Bandwidth and "444-11" means Column Address Strobe (CAS) latency = 4, Row Column Delay (RCD) latency = 4 and Row Precharge (RP) latency = 4 using the latest JEDEC SPD Revision 1.2 and produced on the Raw Card "B".

HYS64T[32/64]0[0/2]0HM-[3S/3.7/5]-A  
Micro-DIMM DDR2 SDRAM Modules**TABLE 3**  
Address Format

DIMM Density	Module Organization	Memory Ranks	ECC/ Non-ECC	# of SDRAMs	# of row/bank/columns bits	Raw Card
256 MByte	32M x64	1	Non-ECC	4	13/2/10	B
512 MByte	64M x64	2	Non-ECC	8	13/2/10	A

**TABLE 4**  
Components on Modules

Product Type <sup>1)</sup>	DRAM Components <sup>1)</sup>	DRAM Density	DRAM Organisation	Note <sup>2)</sup>
HYS64T32000HM	HYB18T512160AF	512 Mbit	32M x16	
HYS64T64020HM	HYB18T512160AF	512 Mbit	32M x16	

1) Green Product

2) For a detailed description of all functionalities of the DRAM components on these modules see the component data sheet.



## 2 Pin Configuration

This chapter contains the pin configuration.

### 2.1 Pin Configuration

The pin configuration of the DDR2 SDRAM Micro-DIMM is listed by function in **Table 5** (214 pins). The abbreviations used in columns Pin and Buffer Type are explained in **Table 6** and **Table 7** respectively. The pin numbering is depicted in **Figure 1**.

**TABLE 5**  
Pin Configuration of MDIMM

Ball No.	Name	Pin Type	Buffer Type	Function
<b>Clock Signals</b>				
122	CK0	I	SSTL	<b>Clock Signal CK 1:0, Complementary Clock Signal CK 1:0</b>
194	CK1	I	SSTL	
123	$\overline{\text{CK0}}$	I	SSTL	
195	$\overline{\text{CK1}}$	I	SSTL	
43	CKE0	I	SSTL	<b>Clock Enables 1:0</b>
147	CKE1	I	SSTL	<i>Note: 2-rank module</i>
	NC	NC		<b>Not Connected</b> <i>Note: 1-rank module</i>
<b>Control Signals</b>				
165	$\overline{\text{S0}}$	I	SSTL	<b>Chip Select Rank 1:0</b> <i>Note: 2-rank module.</i>
62	$\overline{\text{S1}}$	I	SSTL	
	NC	NC		<b>Not Connected</b> <i>Note: 1-rank module</i>
163	$\overline{\text{RAS}}$	I		<b>Row Address Strobe (RAS), Column Address Strobe (CAS), Write Enable (WE)</b>
60	$\overline{\text{CAS}}$	I	SSTL	
56	$\overline{\text{WE}}$	I	SSTL	
<b>Address Signals</b>				
55	BA0	I	SSTL	<b>Bank Address Bus 1:0</b>
162	BA1	I	SSTL	
46	BA2	I	SSTL	<b>Bank Address Bus 2</b> <i>Note: Greater than 512Mb DDR2 SDRAMs</i>
	NC	NC	–	<b>Not Connected</b> <i>Note: Less than 1Gb DDR2 SDRAMs</i>



HYS64T[32/64]0[0/2]0HM-[3S/3.7/5]-A  
Micro-DIMM DDR2 SDRAM Modules

Ball No.	Name	Pin Type	Buffer Type	Function
161	A0	I	SSTL	<b>Address Inputs 12:0, Address Input 10/Autoprecharge</b>
159	A1	I	SSTL	
52	A2	I	SSTL	
158	A3	I	SSTL	
51	A4	I	SSTL	
50	A5	I	SSTL	
157	A6	I	SSTL	
48	A7	I	SSTL	
155	A8	I	SSTL	
154	A9	I	SSTL	
54	A10	I	SSTL	
	AP	I	SSTL	
47	A11	I	SSTL	
153	A12	I	SSTL	
167	A13	I	SSTL	<b>Address Input 13</b> <i>Note: Modules based on <math>\times 4/\times 8</math> component</i>
	NC	NC	–	<b>Not Connected</b> <i>Note: Modules based on <math>\times 16</math> component</i>
<b>Data Signals</b>				
3	DQ0	I/O	SSTL	<b>Data Bus 0:38</b> <i>Note: Data Input/Output pins</i>
4	DQ1	I/O	SSTL	
9	DQ2	I/O	SSTL	
10	DQ3	I/O	SSTL	
109	DQ4	I/O	SSTL	
110	DQ5	I/O	SSTL	
114	DQ6	I/O	SSTL	
115	DQ7	I/O	SSTL	
12	DQ8	I/O	SSTL	



HYS64T[32/64]0[0/2]0HM-[3S/3.7/5]-A  
Micro-DIMM DDR2 SDRAM Modules

Ball No.	Name	Pin Type	Buffer Type	Function	
13	DQ9	I/O	SSTL	<b>Data Bus 0:38</b> <i>Note: Data Input/Output pins</i>	
21	DQ10	I/O	SSTL		
22	DQ11	I/O	SSTL		
117	DQ12	I/O	SSTL		
118	DQ13	I/O	SSTL		
125	DQ14	I/O	SSTL		
126	DQ15	I/O	SSTL		
24	DQ16	I/O	SSTL		
25	DQ17	I/O	SSTL		
30	DQ18	I/O	SSTL		
31	DQ19	I/O	SSTL		
128	DQ20	I/O	SSTL		
129	DQ21	I/O	SSTL		
133	DQ22	I/O	SSTL		
134	DQ23	I/O	SSTL		
33	DQ24	I/O	SSTL		
34	DQ25	I/O	SSTL		
38	DQ26	I/O	SSTL		
39	DQ27	I/O	SSTL		
136	DQ28	I/O	SSTL		
137	DQ29	I/O	SSTL		
142	DQ30	I/O	SSTL		
143	DQ31	I/O	SSTL		
67	DQ32	I/O	SSTL		
68	DQ33	I/O	SSTL		
73	DQ34	I/O	SSTL		
74	DQ35	I/O	SSTL		
174	DQ36	I/O	SSTL		
175	DQ37	I/O	SSTL		
179	DQ38	I/O	SSTL		
180	DQ39	I/O	SSTL		<b>Data Bus 39:57</b>
76	DQ40	I/O	SSTL		
77	DQ41	I/O	SSTL		
81	DQ42	I/O	SSTL		
82	DQ43	I/O	SSTL		
182	DQ44	I/O	SSTL		
183	DQ45	I/O	SSTL		
188	DQ46	I/O	SSTL		
189	DQ47	I/O	SSTL		
84	DQ48	I/O	SSTL		





HYS64T[32/64]0[0/2]0HM-[3S/3.7/5]-A  
Micro-DIMM DDR2 SDRAM Modules

Ball No.	Name	Pin Type	Buffer Type	Function
85	DQ49	I/O	SSTL	<b>Data Bus 39:57</b>
92	DQ50	I/O	SSTL	
93	DQ51	I/O	SSTL	
191	DQ52	I/O	SSTL	
192	DQ53	I/O	SSTL	
200	DQ54	I/O	SSTL	
201	DQ55	I/O	SSTL	
95	DQ56	I/O	SSTL	
96	DQ57	I/O	SSTL	
101	DQ58	I/O	SSTL	
102	DQ59	I/O	SSTL	
203	DQ60	I/O	SSTL	
204	DQ61	I/O	SSTL	
208	DQ62	I/O	SSTL	
209	DQ63	I/O	SSTL	
7	DQS0	I/O	SSTL	
6	$\overline{\text{DQS0}}$	I/O	SSTL	
19	DQS1	I/O	SSTL	
18	$\overline{\text{DQS1}}$	I/O	SSTL	
28	DQS2	I/O	SSTL	
27	$\overline{\text{DQS2}}$	I/O	SSTL	
140	DQS3	I/O	SSTL	
139	$\overline{\text{DQS3}}$	I/O	SSTL	
71	DQS4	I/O	SSTL	
70	$\overline{\text{DQS4}}$	I/O	SSTL	
186	DQS5	I/O	SSTL	
185	$\overline{\text{DQS5}}$	I/O	SSTL	
198	DQS6	I/O	SSTL	
197	$\overline{\text{DQS6}}$	I/O	SSTL	
99	DQS7	I/O	SSTL	
98	$\overline{\text{DQS7}}$	I/O	SSTL	
112	DM0	I	SSTL	<b>Data Masks 7:0</b> <i>Note: <math>\times 8</math> based module</i>
120	DM1	I	SSTL	
131	DM2	I	SSTL	
36	DM3	I	SSTL	
177	DM4	I	SSTL	
79	DM5	I	SSTL	
90	DM6	I	SSTL	
206	DM7	I	SSTL	



HYS64T[32/64]0[0/2]0HM-[3S/3.7/5]-A  
Micro-DIMM DDR2 SDRAM Modules

Ball No.	Name	Pin Type	Buffer Type	Function
<b>EEPROM</b>				
105	SCL	I	CMOS	<b>Serial Bus Clock</b>
104	SDA	I/O	OD	<b>Serial Bus Data</b>
211	SA0	I	CMOS	<b>Serial Address Select Bus 1:0</b>
213	SA1	I	CMOS	
<b>Power Supplies</b>				
1	$V_{REF}$	AI	–	<b>I/O Reference Voltage</b>
42, 45, 49, 53, 57, 61, 64, 146, 149, 152, 156, 160, 164, 168, 171	$V_{DD}$	PWR	–	<b>Power Supply</b>
107	$V_{DDSPD}$	PWR	–	<b>EEPROM Power Supply</b>
2, 5, 8, 11, 14, 17, 20, 23, 26, 29, 32, 35, 37, 40, 66, 69, 72, 75, 78, 80, 83, 86, 89, 91, 94, 97, 100, 103, 108, 111, 113, 116, 119, 121, 124, 127, 130, 132, 135, 138, 141, 144, 173, 176, 178, 181, 184, 187, 190, 193, 196, 205, 199, 202, 207, 210	$V_{SS}$	GND	–	<b>Ground Plane</b>
<b>Other Pins</b>				
166	ODT0	I	SSTL	<b>On-Die Termination Control 1:0</b> <i>Note: 2-rank module</i>
63	ODT1	I	SSTL	<b>On-Die Termination Control 1:0</b> <i>Note: 2-rank module</i>
	NC			<b>Not Connected</b> <i>Note: 1-rank module</i>
15, 16, 41, 44, 46, 58, 59, 65, 87, 88, 106, 145, 148, 150, 151, 167, 169, 170, 172, 212, 214	NC	NC		<b>Not connected</b>

HYS64T[32/64]0[0/2]0HM-[3S/3.7/5]-A  
Micro-DIMM DDR2 SDRAM Modules**TABLE 6**  
Abbreviations for Pin Type

Abbreviation	Description
I	Standard input-only pin. Digital levels.
O	Output. Digital levels.
I/O	I/O is a bidirectional input/output signal.
AI	Input. Analog levels.
PWR	Power
GND	Ground
NC	Not Connected

**TABLE 7**  
Abbreviations for Buffer Type

Abbreviation	Description
SSTL	Serial Stub Terminated Logic (SSTL_18)
CMOS	CMOS Levels
OD	Open Drain. The corresponding pin has 2 operational states, active low and tristate, and allows multiple devices to share as a wire-OR.



HYS64T[32/64]0[0/2]0HM-[3S/3.7/5]-A  
Micro-DIMM DDR2 SDRAM Modules

FIGURE 1

## Pin Configuration for Two-Piece Mezzanine Socket on MDIMM (214 pins)

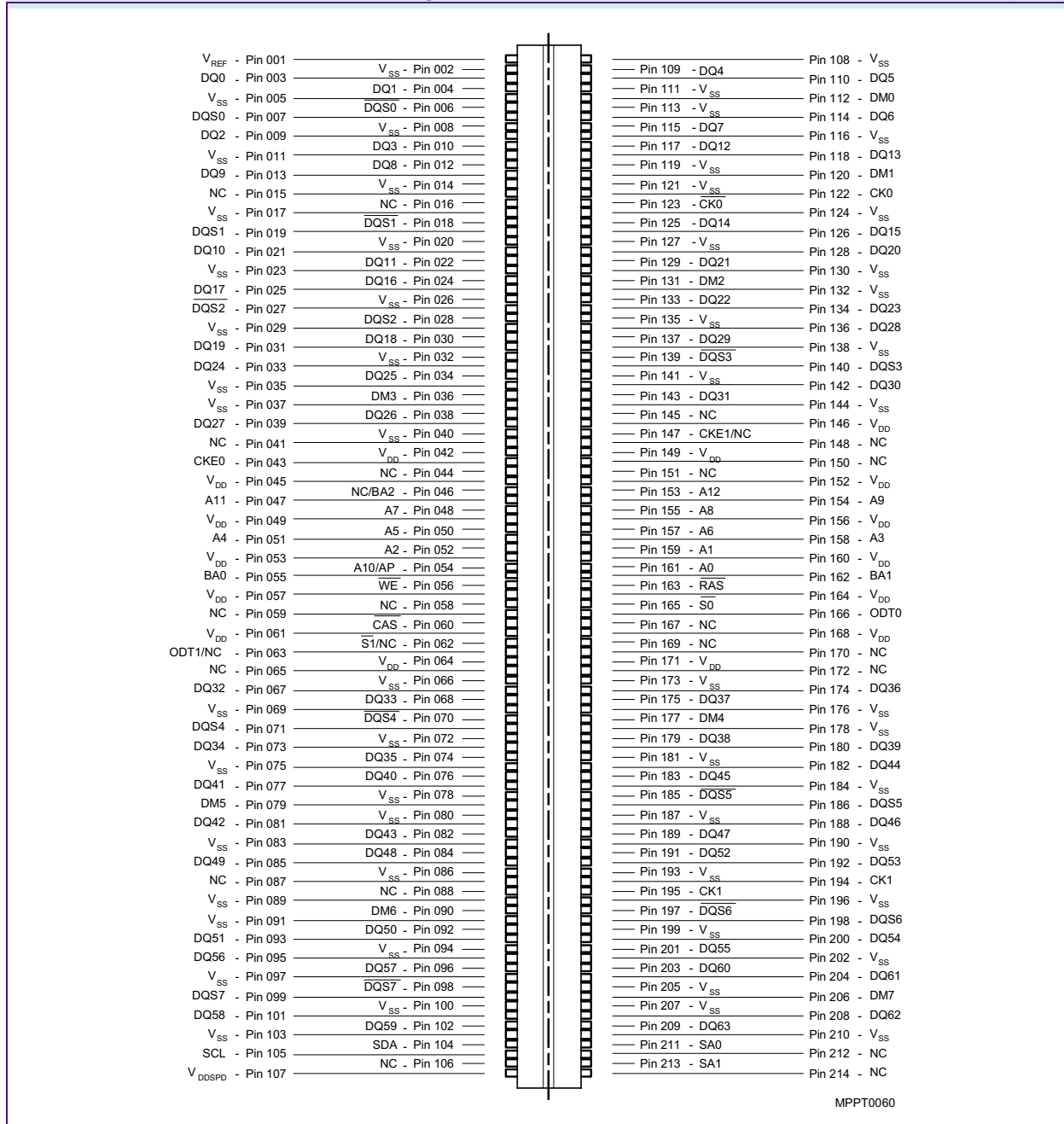



## 3 Electrical Characteristics

This chapter lists the electrical characteristics.

### 3.1 Absolute Maximum Ratings

Caution is needed not to exceed absolute maximum ratings of the DRAM device listed in **Table 8** at any time.

**TABLE 8**  
Absolute Maximum Ratings

Symbol	Parameter	Rating		Unit	Note
		Min.	Max.		
$V_{DD}$	Voltage on $V_{DD}$ pin relative to $V_{SS}$	-1.0	+2.3	V	1)
$V_{DDQ}$	Voltage on $V_{DDQ}$ pin relative to $V_{SS}$	-0.5	+2.3	V	1)2)
$V_{DDL}$	Voltage on $V_{DDL}$ pin relative to $V_{SS}$	-0.5	+2.3	V	1)2)
$V_{IN}, V_{OUT}$	Voltage on any pin relative to $V_{SS}$	-0.5	+2.3	V	1)
$T_{STG}$	Storage Temperature	-55	+100	°C	1)2)

1) When  $V_{DD}$  and  $V_{DDQ}$  and  $V_{DDL}$  are less than 500 mV;  $V_{REF}$  may be equal to or less than 300 mV.

2) Storage Temperature is the case surface temperature on the center/top side of the DRAM.

**Attention: Stresses greater than those listed under “Absolute Maximum Ratings” may cause permanent damage to the device. This is a stress rating only and functional operation of the device at these or any other conditions above those indicated in the operational sections of this specification is not implied. Exposure to absolute maximum rating conditions for extended periods may affect reliability.**

**TABLE 9**  
DRAM Component Operating Temperature Range

Symbol	Parameter	Rating		Unit	Note
		Min.	Max.		
$T_{OPER}$	Operating Temperature	0	95	°C	1)2)3)4)

1) Operating Temperature is the case surface temperature on the center / top side of the DRAM.

2) The operating temperature range are the temperatures where all DRAM specification will be supported. During operation, the DRAM case temperature must be maintained between 0 - 95 °C under all other specification parameters.

3) Above 85 °C the Auto-Refresh command interval has to be reduced to  $t_{REFI} = 3.9 \mu s$

4) When operating this product in the 85 °C to 95 °C TCASE temperature range, the High Temperature Self Refresh has to be enabled by setting EMR(2) bit A7 to “1”. When the High Temperature Self Refresh is enabled there is an increase of  $I_{DD6}$  by approximately 50%



### 3.2 DC Operating Conditions

This chapter contains the DC operating conditions tables.

**TABLE 10**  
Operating Conditions

Parameter	Symbol	Values		Unit	Note
		Min.	Max.		
Operating temperature (ambient)	$T_{OPR}$	0	+65	°C	
DRAM Case Temperature	$T_{CASE}$	0	+95	°C	1)2)3)4)
Storage Temperature	$T_{STG}$	- 50	+100	°C	
Barometric Pressure (operating & storage)	PBar	+69	+105	kPa	5)
Operating Humidity (relative)	$H_{OPR}$	10	90	%	

- 1) DRAM Component Case Temperature is the surface temperature in the center on the top side of any of the DRAMs.
- 2) Within the DRAM Component Case Temperature Range all DRAM specifications will be supported
- 3) Above 85 °C DRAM Case Temperature the Auto-Refresh command interval has to be reduced to  $t_{REFI} = 3.9 \mu s$
- 4) When operating this product in the 85 °C to 95 °C  $T_{CASE}$  temperature range, the High Temperature Self Refresh has to be enabled by setting EMR(2) bit A7 to "1". When the High Temperature Self Refresh is enabled there is an increase of  $I_{DD6}$  by approximately 50%.
- 5) Up to 3000 m.

**TABLE 11**  
Supply Voltage Levels and DC Operating Conditions

Parameter	Symbol	Values			Unit	Note
		Min.	Typ.	Max.		
Device Supply Voltage	$V_{DD}$	1.7	1.8	1.9	V	
Output Supply Voltage	$V_{DDQ}$	1.7	1.8	1.9	V	1)
Input Reference Voltage	$V_{REF}$	$0.49 \times V_{DDQ}$	$0.5 \times V_{DDQ}$	$0.51 \times V_{DDQ}$	V	2)
SPD Supply Voltage	$V_{DDSPD}$	1.7	—	3.6	V	
DC Input Logic High	$V_{IH(DC)}$	$V_{REF} + 0.125$	—	$V_{DDQ} + 0.3$	V	
DC Input Logic Low	$V_{IL(DC)}$	- 0.30	—	$V_{REF} - 0.125$	V	
In / Output Leakage Current	$I_L$	- 5	—	5	$\mu A$	3)

- 1) Under all conditions,  $V_{DDQ}$  must be less than or equal to  $V_{DD}$
- 2) Peak to peak AC noise on  $V_{REF}$  may not exceed  $\pm 2\% V_{REF(DC)}$ .  $V_{REF}$  is also expected to track noise in  $V_{DDQ}$ .
- 3) Input voltage for any connector pin under test of  $0 V \leq V_{IN} \leq V_{DDQ} + 0.3 V$ ; all other pins at 0 V. Current is per pin



### 3.3 Timing Characteristics

This chapter describes the AC characteristics.

#### 3.3.1 Speed Grade Definitions

This chapter contains the Speed Grade Definition tables.

**TABLE 12**  
Speed Grade Definition Speed Bins for DDR2-667D, DDR2-533C and DDR2-400B

Speed Grade		DDR2-667D		DDR2-533C		DDR2-400B		Unit	Note	
QAG Sort Name		-3S		-3.7		-5				
CAS-RCD-RP latencies		5-5-5		4-4-4		3-3-3		$t_{CK}$		
Parameter	Symbol	Min.	Max.	Min.	Max.	Min.	Max.	—		
Clock Frequency	@ CL = 3	$t_{CK}$	5	8	5	8	5	8	ns	1)2)3)4)
	@ CL = 4	$t_{CK}$	3.75	8	3.75	8	5	8	ns	1)2)3)4)
	@ CL = 5	$t_{CK}$	3	8	3.75	8	5	8	ns	1)2)3)4)
Row Active Time	$t_{RAS}$	45	70000	45	70000	40	70000	ns	1)2)3)4)5)	
Row Cycle Time	$t_{RC}$	60	—	60	—	55	—	ns	1)2)3)4)	
RAS-CAS-Delay	$t_{RCD}$	15	—	15	—	15	—	ns	1)2)3)4)	
Row Precharge Time	$t_{RP}$	15	—	15	—	15	—	ns	1)2)3)4)	

- 1) Timings are guaranteed with  $\overline{CK}/\overline{CK}$  differential Slew Rate of 2.0 V/ns. For DQS signals timings are guaranteed with a differential Slew Rate of 2.0 V/ns in differential strobe mode and a Slew Rate of 1 V/ns in single ended mode. Timings are further guaranteed for normal OCD drive strength (EMRS(1) A1 = 0) only.
- 2) The  $\overline{CK}/\overline{CK}$  input reference level (for timing reference to  $\overline{CK}/\overline{CK}$ ) is the point at which  $\overline{CK}$  and  $\overline{CK}$  cross. The  $\overline{DQS}/\overline{DQS}$ ,  $\overline{RDQS}/\overline{RDQS}$ , input reference level is the crosspoint when in differential strobe mode
- 3) Inputs are not recognized as valid until  $V_{REF}$  stabilizes. During the period before  $V_{REF}$  stabilizes,  $CKE = 0.2 \times V_{DDQ}$  is recognized as low.
- 4) The output timing reference voltage level is  $V_{TT}$ .
- 5)  $t_{RAS,MAX}$  is calculated from the maximum amount of time a DDR2 device can operate without a refresh command which is equal to  $9 \times t_{REFI}$ .



### 3.3.2 Component AC Timing Parameters

This chapter contains the AC Timing Parameters.

**TABLE 13**  
**DRAM Component Timing Parameter by Speed Grade - DDR2-667**

Parameter	Symbol	DDR2-667		Unit	Note 1)2)3)4)5)6)7)8)
		Min.	Max.		
DQ output access time from CK / $\overline{\text{CK}}$	$t_{AC}$	-450	+450	ps	9)
DQS output access time from CK / $\overline{\text{CK}}$	$t_{DQSCK}$	-400	+400	ps	9)
Average clock high pulse width	$t_{CH.AVG}$	0.48	0.52	$t_{CK.AVG}$	10)11)
Average clock low pulse width	$t_{CL.AVG}$	0.48	0.52	$t_{CK.AVG}$	10)11)
Average clock period	$t_{CK.AVG}$	3000	8000	ps	
DQ and DM input setup time	$t_{DS.BASE}$	100	—	ps	12)13)14)
DQ and DM input hold time	$t_{DH.BASE}$	175	—	ps	13)14)15)
Control & address input pulse width for each input	$t_{IPW}$	0.6	—	$t_{CK.AVG}$	
DQ and DM input pulse width for each input	$t_{DIPW}$	0.35	—	$t_{CK.AVG}$	
Data-out high-impedance time from CK / $\overline{\text{CK}}$	$t_{HZ}$	—	$t_{AC.MAX}$	ps	9)16)
DQS/ $\overline{\text{DQS}}$ low-impedance time from CK / $\overline{\text{CK}}$	$t_{LZ.DQS}$	$t_{AC.MIN}$	$t_{AC.MAX}$	ps	9)16)
DQ low impedance time from CK/ $\overline{\text{CK}}$	$t_{LZ.DQ}$	2 x $t_{AC.MIN}$	$t_{AC.MAX}$	ps	9)16)
DQS-DQ skew for DQS & associated DQ signals	$t_{DQSQ}$	—	240	ps	17)
CK half pulse width	$t_{HP}$	Min( $t_{CH.ABS}$ , $t_{CL.ABS}$ )	—	ps	18)
DQ hold skew factor	$t_{QHS}$	—	340	ps	19)
DQ/DQS output hold time from DQS	$t_{QH}$	$t_{HP} - t_{QHS}$	—	ps	20)
Write command to DQS associated clock edges	WL	RL-1		nCK	
DQS latching rising transition to associated clock edges	$t_{DQSS}$	- 0.25	+ 0.25	$t_{CK.AVG}$	21)
DQS input high pulse width	$t_{DQSH}$	0.35	—	$t_{CK.AVG}$	
DQS input low pulse width	$t_{DQSL}$	0.35	—	$t_{CK.AVG}$	
DQS falling edge to CK setup time	$t_{DSS}$	0.2	—	$t_{CK.AVG}$	21)
DQS falling edge hold time from CK	$t_{DSH}$	0.2	—	$t_{CK.AVG}$	21)
Write postamble	$t_{WPST}$	0.4	0.6	$t_{CK.AVG}$	
Write preamble	$t_{WPRE}$	0.35	—	$t_{CK.AVG}$	
Address and control input setup time	$t_{IS.BASE}$	200	—	ps	22)23)
Address and control input hold time	$t_{IH.BASE}$	275	—	ps	23)24)
Read preamble	$t_{RPRE}$	0.9	1.1	$t_{CK.AVG}$	25)26)
Read postamble	$t_{RPST}$	0.4	0.6	$t_{CK.AVG}$	25)27)
CAS to CAS command delay	$t_{CCD}$	2	—	nCK	
Write recovery time	$t_{WR}$	15	—	ns	28)
Auto-Precharge write recovery + precharge time	$t_{DAL}$	WR + $t_{nRP}$	—	nCK	29)30)
Internal write to read command delay	$t_{WTR}$	7.5	—	ns	28)31)





HYS64T[32/64]0[0/2]0HM-[3S/3.7/5]-A  
Micro-DIMM DDR2 SDRAM Modules

Parameter	Symbol	DDR2-667		Unit	Note 1)2)3)4)5)6)7)8)
		Min.	Max.		
Internal Read to Precharge command delay	$t_{RTP}$	7.5	—	ns	28)
Exit self-refresh to a non-read command	$t_{XSNR}$	$t_{RFC} + 10$	—	ns	28)
Exit self-refresh to read command	$t_{XSRD}$	200	—	nCK	
Exit precharge power-down to any valid command (other than NOP or Deselect)	$t_{XP}$	2	—	nCK	
Exit power down to read command	$t_{XARD}$	2	—	nCK	
Exit active power-down mode to read command (slow exit, lower power)	$t_{XARDS}$	7 – AL	—	nCK	
CKE minimum pulse width ( high and low pulse width)	$t_{CKE}$	3	—	nCK	32)
Mode register set command cycle time	$t_{MRD}$	2	—	nCK	
MRS command to ODT update delay	$t_{MOD}$	0	12	ns	28)
OCD drive mode output delay	$t_{OIT}$	0	12	ns	28)
Minimum time clocks remain ON after CKE asynchronously drops LOW	$t_{DELAY}$	$t_{IS} + t_{CK.AVG} + t_{IH}$	—	ns	

- 1) For details and notes see the relevant Qimonda component data sheet
- 2)  $V_{DDQ} = 1.8 V \pm 0.1 V$ ;  $V_{DD} = 1.8 V \pm 0.1 V$ . See notes 5)6)7)8)
- 3) Timing that is not specified is illegal and after such an event, in order to guarantee proper operation, the DRAM must be powered down and then restarted through the specified initialization sequence before normal operation can continue.
- 4) Timings are guaranteed with CK/CK differential Slew Rate of 2.0 V/ns. For DQS signals timings are guaranteed with a differential Slew Rate of 2.0 V/ns in differential strobe mode and a Slew Rate of 1 V/ns in single ended mode.
- 5) The CK / CK input reference level (for timing reference to CK / CK) is the point at which CK and CK cross. The DQS / DQS, RDQS / RDQS, input reference level is the crosspoint when in differential strobe mode.
- 6) Inputs are not recognized as valid until  $V_{REF}$  stabilizes. During the period before  $V_{REF}$  stabilizes,  $CKE = 0.2 \times V_{DDQ}$  is recognized as low.
- 7) The output timing reference voltage level is  $V_{TT}$ .
- 8) New units, 't<sub>CK,AVG</sub>' and 'nCK', are introduced in DDR2-667 and DDR2-800. Unit 't<sub>CK,AVG</sub>' represents the actual t<sub>CK,AVG</sub> of the input clock under operation. Unit 'nCK' represents one clock cycle of the input clock, counting the actual clock edges. Note that in DDR2-400 and DDR2-533, 't<sub>CK</sub>' is used for both concepts. Example: t<sub>XP</sub> = 2 [nCK] means; if Power Down exit is registered at Tm, an Active command may be registered at Tm + 2, even if (Tm + 2 - Tm) is 2 x t<sub>CK,AVG</sub> + t<sub>ERR,2PER(MIN)</sub>.
- 9) When the device is operated with input clock jitter, this parameter needs to be derated by the actual t<sub>ERR(6-10per)</sub> of the input clock. (output deratings are relative to the SDRAM input clock.) For example, if the measured jitter into a DDR2-667 SDRAM has t<sub>ERR(6-10PER),MIN</sub> = - 272 ps and t<sub>ERR(6-10PER),MAX</sub> = + 293 ps, then t<sub>DQSK,MIN(DERATED)</sub> = t<sub>DQSK,MIN</sub> - t<sub>ERR(6-10PER),MAX</sub> = - 400 ps - 293 ps = - 693 ps and t<sub>DQSK,MAX(DERATED)</sub> = t<sub>DQSK,MAX</sub> - t<sub>ERR(6-10PER),MIN</sub> = 400 ps + 272 ps = + 672 ps. Similarly, t<sub>LZ,DQ</sub> for DDR2-667 derates to t<sub>LZ,DQ,MIN(DERATED)</sub> = - 900 ps - 293 ps = - 1193 ps and t<sub>LZ,DQ,MAX(DERATED)</sub> = 450 ps + 272 ps = + 722 ps. (Caution on the MIN/MAX usage!)
- 10) Input clock jitter spec parameter. These parameters are referred to as 'input clock jitter spec parameters' and these parameters apply to DDR2-667 and DDR2-800 only. The jitter specified is a random jitter meeting a Gaussian distribution.
- 11) These parameters are specified per their average values, however it is understood that the relationship between the average timing and the absolute instantaneous timing holds all the times (min. and max of SPEC values are to be used for calculations ).
- 12) Input waveform timing t<sub>DS</sub> with differential data strobe enabled MR[bit10] = 0, is referenced from the input signal crossing at the V<sub>IH,AC</sub> level to the differential data strobe crosspoint for a rising signal, and from the input signal crossing at the V<sub>IL,AC</sub> level to the differential data strobe crosspoint for a falling signal applied to the device under test. DQS, DQS signals must be monotonic between V<sub>I(DC),MAX</sub> and V<sub>I(DC),MIN</sub>. See Figure 3.
- 13) If t<sub>DS</sub> or t<sub>DH</sub> is violated, data corruption may occur and the data must be re-written with valid data before a valid READ can be executed.
- 14) These parameters are measured from a data signal ((L/U)DM, (L/U)DQ0, (L/U)DQ1, etc.) transition edge to its respective data strobe signal ((L/U/R)DQS / DQS) crossing.
- 15) Input waveform timing t<sub>DH</sub> with differential data strobe enabled MR[bit10] = 0, is referenced from the differential data strobe crosspoint to the input signal crossing at the V<sub>IH,DC</sub> level for a falling signal and from the differential data strobe crosspoint to the input signal crossing at the V<sub>IL,DC</sub> level for a rising signal applied to the device under test. DQS, DQS signals must be monotonic between V<sub>IL,DC,MAX</sub> and V<sub>IH,DC,MIN</sub>. See Figure 3.

HYS64T[32/64]0[0/2]0HM-[3S/3.7/5]-A  
Micro-DIMM DDR2 SDRAM Modules

- 16)  $t_{HZ}$  and  $t_{LZ}$  transitions occur in the same access time as valid data transitions. These parameters are referenced to a specific voltage level which specifies when the device output is no longer driving ( $t_{HZ}$ ), or begins driving ( $t_{LZ}$ ).
- 17)  $t_{DQSQ}$ : Consists of data pin skew and output pattern effects, and p-channel to n-channel variation of the output drivers as well as output slew rate mismatch between  $DQS / \overline{DQS}$  and associated DQ in any given cycle.
- 18)  $t_{HP}$  is the minimum of the absolute half period of the actual input clock.  $t_{HP}$  is an input parameter but not an input specification parameter. It is used in conjunction with  $t_{QHS}$  to derive the DRAM output timing  $t_{QH}$ . The value to be used for  $t_{QH}$  calculation is determined by the following equation;  $t_{HP} = \text{MIN}(t_{CH,ABS}, t_{CL,ABS})$ , where,  $t_{CH,ABS}$  is the minimum of the actual instantaneous clock high time;  $t_{CL,ABS}$  is the minimum of the actual instantaneous clock low time.
- 19)  $t_{QHS}$  accounts for: 1) The pulse duration distortion of on-chip clock circuits, which represents how well the actual  $t_{HP}$  at the input is transferred to the output; and 2) The worst case push-out of DQS on one transition followed by the worst case pull-in of DQ on the next transition, both of which are independent of each other, due to data pin skew, output pattern effects, and pchannel to n-channel variation of the output drivers.
- 20)  $t_{QH} = t_{HP} - t_{QHS}$ , where:  $t_{HP}$  is the minimum of the absolute half period of the actual input clock; and  $t_{QHS}$  is the specification value under the max column. {The less half-pulse width distortion present, the larger the  $t_{QH}$  value is; and the larger the valid data eye will be.}  
Examples: 1) If the system provides  $t_{HP}$  of 1315 ps into a DDR2–667 SDRAM, the DRAM provides  $t_{QH}$  of 975 ps minimum. 2) If the system provides  $t_{HP}$  of 1420 ps into a DDR2–667 SDRAM, the DRAM provides  $t_{QH}$  of 1080 ps minimum.
- 21) These parameters are measured from a data strobe signal ((L/U/R)DQS /  $\overline{DQS}$ ) crossing to its respective clock signal (CK /  $\overline{CK}$ ) crossing. The spec values are not affected by the amount of clock jitter applied (i.e.  $t_{JIT,PER}$ ,  $t_{JIT,CC}$ , etc.), as these are relative to the clock signal crossing. That is, these parameters should be met whether clock jitter is present or not.
- 22) Input waveform timing is referenced from the input signal crossing at the  $V_{IH,AC}$  level for a rising signal and  $V_{IL,AC}$  for a falling signal applied to the device under test. See **Figure 4**.
- 23) These parameters are measured from a command/address signal (CKE, CS, RAS, CAS, WE, ODT, BA0, A0, A1, etc.) transition edge to its respective clock signal (CK /  $\overline{CK}$ ) crossing. The spec values are not affected by the amount of clock jitter applied (i.e.  $t_{JIT,PER}$ ,  $t_{JIT,CC}$ , etc.), as the setup and hold are relative to the clock signal crossing that latches the command/address. That is, these parameters should be met whether clock jitter is present or not.
- 24) Input waveform timing is referenced from the input signal crossing at the  $V_{IH,DC}$  level for a rising signal and  $V_{IL,DC}$  for a falling signal applied to the device under test. See **Figure 4**.
- 25)  $t_{RPST}$  end point and  $t_{RPRE}$  begin point are not referenced to a specific voltage level but specify when the device output is no longer driving ( $t_{RPST}$ ), or begins driving ( $t_{RPRE}$ ). **Figure 2** shows a method to calculate these points when the device is no longer driving ( $t_{RPST}$ ), or begins driving ( $t_{RPRE}$ ) by measuring the signal at two different voltages. The actual voltage measurement points are not critical as long as the calculation is consistent.
- 26) When the device is operated with input clock jitter, this parameter needs to be derated by the actual  $t_{JIT,PER}$  of the input clock. (output deratings are relative to the SDRAM input clock.) For example, if the measured jitter into a DDR2–667 SDRAM has  $t_{JIT,PER,MIN} = -72$  ps and  $t_{JIT,PER,MAX} = +93$  ps, then  $t_{RPRE,MIN(DERATED)} = t_{RPRE,MIN} + t_{JIT,PER,MIN} = 0.9 \times t_{CK,AVG} - 72$  ps = + 2178 ps and  $t_{RPRE,MAX(DERATED)} = t_{RPRE,MAX} + t_{JIT,PER,MAX} = 1.1 \times t_{CK,AVG} + 93$  ps = + 2843 ps. (Caution on the MIN/MAX usage!).
- 27) When the device is operated with input clock jitter, this parameter needs to be derated by the actual  $t_{JIT,DUTY}$  of the input clock. (output deratings are relative to the SDRAM input clock.) For example, if the measured jitter into a DDR2–667 SDRAM has  $t_{JIT,DUTY,MIN} = -72$  ps and  $t_{JIT,DUTY,MAX} = +93$  ps, then  $t_{RPST,MIN(DERATED)} = t_{RPST,MIN} + t_{JIT,DUTY,MIN} = 0.4 \times t_{CK,AVG} - 72$  ps = + 928 ps and  $t_{RPST,MAX(DERATED)} = t_{RPST,MAX} + t_{JIT,DUTY,MAX} = 0.6 \times t_{CK,AVG} + 93$  ps = + 1592 ps. (Caution on the MIN/MAX usage!).
- 28) For these parameters, the DDR2 SDRAM device is characterized and verified to support  $t_{nPARAM} = \text{RU}\{t_{PARAM} / t_{CK,AVG}\}$ , which is in clock cycles, assuming all input clock jitter specifications are satisfied. For example, the device will support  $t_{nRP} = \text{RU}\{t_{RP} / t_{CK,AVG}\}$ , which is in clock cycles, if all input clock jitter specifications are met. This means: For DDR2–667 5–5–5, of which  $t_{RP} = 15$  ns, the device will support  $t_{nRP} = \text{RU}\{t_{RP} / t_{CK,AVG}\} = 5$ , i.e. as long as the input clock jitter specifications are met, Precharge command at Tm and Active command at Tm + 5 is valid even if (Tm + 5 - Tm) is less than 15 ns due to input clock jitter.
- 29)  $DAL = \text{WR} + \text{RU}\{t_{RP}(\text{ns}) / t_{CK}(\text{ns})\}$ , where RU stands for round up. WR refers to the tWR parameter stored in the MRS. For  $t_{RP}$ , if the result of the division is not already an integer, round up to the next highest integer.  $t_{CK}$  refers to the application clock period. Example: For DDR2–533 at  $t_{CK} = 3.75$  ns with  $t_{WR}$  programmed to 4 clocks.  $t_{DAL} = 4 + (15 \text{ ns} / 3.75 \text{ ns}) \text{ clocks} = 4 + (4) \text{ clocks} = 8 \text{ clocks}$ .
- 30)  $t_{DAL,nCK} = \text{WR} [\text{nCK}] + t_{nRP,nCK} = \text{WR} + \text{RU}\{t_{RP} [\text{ps}] / t_{CK,AVG}[\text{ps}]\}$ , where WR is the value programmed in the EMR.
- 31)  $t_{WTR}$  is at least two clocks ( $2 \times t_{CK}$ ) independent of operation frequency.
- 32)  $t_{CKE,MIN}$  of 3 clocks means CKE must be registered on three consecutive positive clock edges. CKE must remain at the valid input level the entire time it takes to achieve the 3 clocks of registration. Thus, after any CKE transition, CKE may not transition from its valid level during the time period of  $t_{IS} + 2 \times t_{CK} + t_{IH}$ .



**FIGURE 2**

**Method for calculating transitions and endpoint**

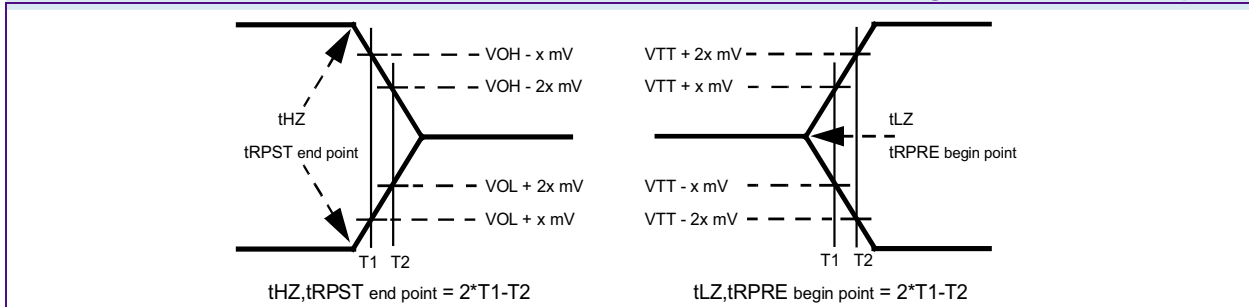

**FIGURE 3**

**Differential input waveform timing -  $t_{DS}$  and  $t_{DH}$**

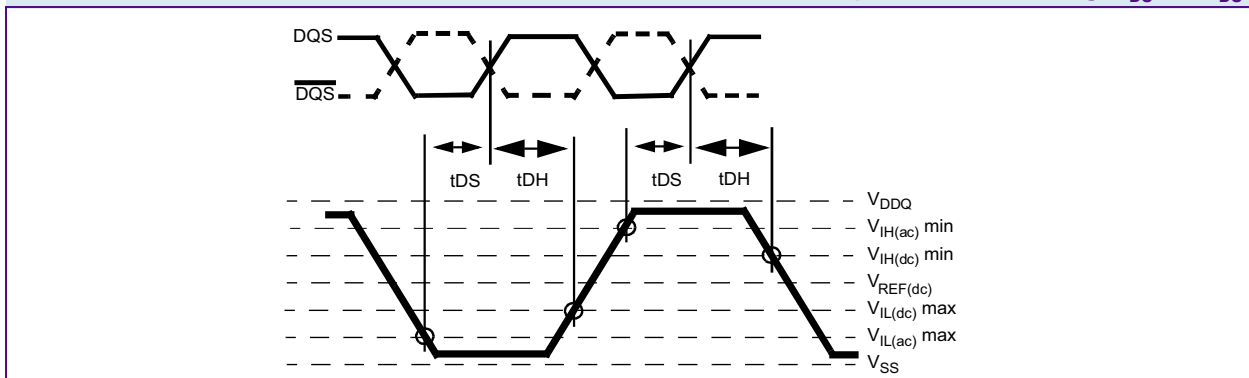

**FIGURE 4**

**Differential input waveform timing -  $t_{IS}$  and  $t_{IH}$**

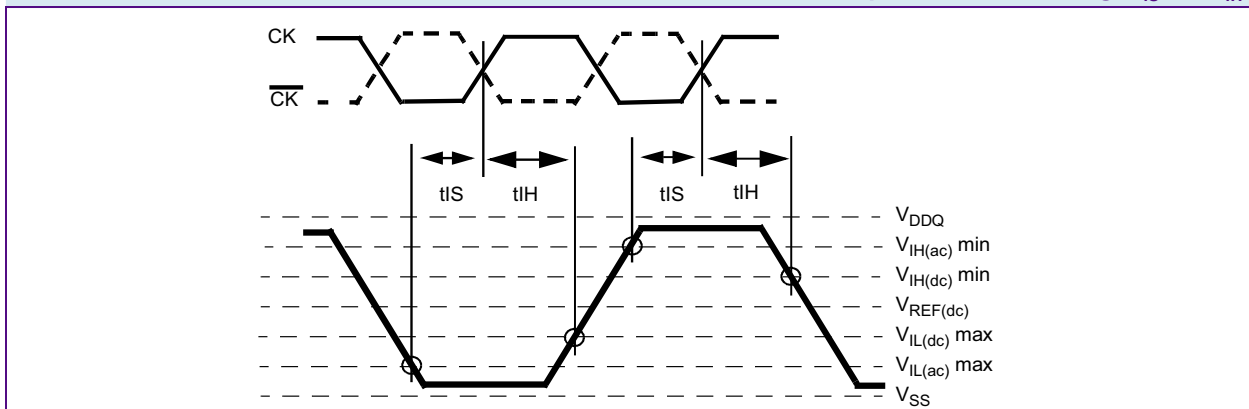

 HYS64T[32/64]0[0/2]0HM-[3S/3.7/5]-A  
 Micro-DIMM DDR2 SDRAM Modules

**TABLE 14**  
**DRAM Component Timing Parameter by Speed Grade - DDR2-533**

Parameter	Symbol	DDR2-533		Unit	Note 1)2)3)4)5)6)7)
		Min.	Max.		
DQ output access time from CK / $\overline{\text{CK}}$	$t_{AC}$	-500	+500	ps	
CAS A to CAS B command period	$t_{CCD}$	2	—	$t_{CK}$	
CK, $\overline{\text{CK}}$ high-level width	$t_{CH}$	0.45	0.55	$t_{CK}$	
CKE minimum high and low pulse width	$t_{CKE}$	3	—	$t_{CK}$	
CK, $\overline{\text{CK}}$ low-level width	$t_{CL}$	0.45	0.55	$t_{CK}$	
Auto-Precharge write recovery + precharge time	$t_{DAL}$	WR + $t_{RP}$	—	$t_{CK}$	8)18)
Minimum time clocks remain ON after CKE asynchronously drops LOW	$t_{DELAY}$	$t_{IS} + t_{CK} + t_{IH}$	—	ns	9)
DQ and DM input hold time (differential data strobe)	$t_{DH}(\text{base})$	225	—	ps	10)
DQ and DM input hold time (single ended data strobe)	$t_{DH1}(\text{base})$	-25	—	ps	11)
DQ and DM input pulse width (each input)	$t_{DIPW}$	0.35	—	$t_{CK}$	
DQS output access time from CK / $\overline{\text{CK}}$	$t_{DQSQ}$	-450	+450	ps	
DQS input low (high) pulse width (write cycle)	$t_{DQSL,H}$	0.35	—	$t_{CK}$	
DQS-DQ skew (for DQS & associated DQ signals)	$t_{DQSQ}$	—	300	ps	11)
Write command to 1st DQS latching transition	$t_{DQSS}$	- 0.25	+ 0.25	$t_{CK}$	
DQ and DM input setup time (differential data strobe)	$t_{DS}(\text{base})$	100	—	ps	11)
DQ and DM input setup time (single ended data strobe)	$t_{DS1}(\text{base})$	-25	—	ps	11)
DQS falling edge hold time from CK (write cycle)	$t_{DSH}$	0.2	—	$t_{CK}$	
DQS falling edge to CK setup time (write cycle)	$t_{DSS}$	0.2	—	$t_{CK}$	
Clock half period	$t_{HP}$	MIN. ( $t_{CL}, t_{CH}$ )		—	12)
Data-out high-impedance time from CK / $\overline{\text{CK}}$	$t_{HZ}$	—	$t_{AC,MAX}$	ps	13)
Address and control input hold time	$t_{IH}(\text{base})$	375	—	ps	11)
Address and control input pulse width (each input)	$t_{IPW}$	0.6	—	$t_{CK}$	
Address and control input setup time	$t_{IS}(\text{base})$	250	—	ps	11)
DQ low-impedance time from CK / $\overline{\text{CK}}$	$t_{LZ}(\text{DQ})$	$2 \times t_{AC,MIN}$	$t_{AC,MAX}$	ps	14)
DQS low-impedance from CK / $\overline{\text{CK}}$	$t_{LZ}(\text{DQS})$	$t_{AC,MIN}$	$t_{AC,MAX}$	ps	14)
Mode register set command cycle time	$t_{MRD}$	2	—	$t_{CK}$	
OCD drive mode output delay	$t_{OIT}$	0	12	ns	
Data output hold time from DQS	$t_{QH}$	$t_{HP} - t_{QHS}$	—	—	
Data hold skew factor	$t_{QHS}$	—	400	ps	



HYS64T[32/64]0[0/2]0HM-[3S/3.7/5]-A  
Micro-DIMM DDR2 SDRAM Modules

Parameter	Symbol	DDR2-533		Unit	Note 1)2)3)4)5)6)7)
		Min.	Max.		
Average periodic refresh Interval	$t_{REFI}$	—	7.8	$\mu\text{S}$	14)15)
		—	3.9	$\mu\text{S}$	16)18)
Auto-Refresh to Active/Auto-Refresh command period	$t_{RFC}$	105	—	ns	17)
Precharge-All (4 banks) command period	$t_{RP}$	$t_{RP} + 1t_{CK}$	—	ns	
Precharge-All (8 banks) command period	$t_{RP}$	$15 + 1t_{CK}$	—	ns	
Read preamble	$t_{RPRE}$	0.9	1.1	$t_{CK}$	14)
Read postamble	$t_{RPST}$	0.40	0.60	$t_{CK}$	14)
Active bank A to Active bank B command period	$t_{RRD}$	7.5	—	ns	14)18)
		10	—	ns	16)20)
Internal Read to Precharge command delay	$t_{RTP}$	7.5	—	ns	
Write preamble	$t_{WPRE}$	0.25	—	$t_{CK}$	
Write postamble	$t_{WPST}$	0.40	0.60	$t_{CK}$	19)
Write recovery time for write without Auto-Precharge	$t_{WR}$	15	—	ns	
Write recovery time for write with Auto-Precharge	WR	$t_{WR}/t_{CK}$	—	$t_{CK}$	20)
Internal Write to Read command delay	$t_{WTR}$	7.5	—	ns	21)
Exit power down to any valid command (other than NOP or Deselect)	$t_{XARD}$	2	—	$t_{CK}$	22)
Exit active power-down mode to Read command (slow exit, lower power)	$t_{XARDS}$	6 – AL	—	$t_{CK}$	22)
Exit precharge power-down to any valid command (other than NOP or Deselect)	$t_{XP}$	2	—	$t_{CK}$	
Exit Self-Refresh to non-Read command	$t_{XSNR}$	$t_{RFC} + 10$	—	ns	
Exit Self-Refresh to Read command	$t_{XSRD}$	200	—	$t_{CK}$	

- 1) For details and notes see the relevant Qimonda component data sheet
- 2)  $V_{DDQ} = 1.8 \text{ V} \pm 0.1 \text{ V}$ ;  $V_{DD} = 1.8 \text{ V} \pm 0.1 \text{ V}$ . See notes 5)6)7)8)
- 3) Timing that is not specified is illegal and after such an event, in order to guarantee proper operation, the DRAM must be powered down and then restarted through the specified initialization sequence before normal operation can continue.
- 4) Timings are guaranteed with  $CK/\overline{CK}$  differential Slew Rate of 2.0 V/ns. For DQS signals timings are guaranteed with a differential Slew Rate of 2.0 V/ns in differential strobe mode and a Slew Rate of 1 V/ns in single ended mode.
- 5) The  $CK / \overline{CK}$  input reference level (for timing reference to  $CK / \overline{CK}$ ) is the point at which  $CK$  and  $\overline{CK}$  cross. The  $DQS / \overline{DQS}$ ,  $RDQS / \overline{RDQS}$ , input reference level is the crosspoint when in differential strobe mode.
- 6) Inputs are not recognized as valid until  $V_{REF}$  stabilizes. During the period before  $V_{REF}$  stabilizes,  $CKE = 0.2 \times V_{DDQ}$  is recognized as low.
- 7) The output timing reference voltage level is  $V_{TT}$ .
- 8) For each of the terms, if not already an integer, round to the next highest integer.  $t_{CK}$  refers to the application clock period. WR refers to the WR parameter stored in the MR.
- 9) The clock frequency is allowed to change during self-refresh mode or precharge power-down mode.
- 10) For timing definition, refer to the Component data sheet.
- 11) Consists of data pin skew and output pattern effects, and p-channel to n-channel variation of the output drivers as well as output Slew Rate mis-match between  $DQS / \overline{DQS}$  and associated DQ in any given cycle.
- 12) MIN ( $t_{CL}$ ,  $t_{CH}$ ) refers to the smaller of the actual clock low time and the actual clock high time as provided to the device (i.e. this value can be greater than the minimum specification limits for  $t_{CL}$  and  $t_{CH}$ ).

HYS64T[32/64]0[0/2]0HM-[3S/3.7/5]-A  
Micro-DIMM DDR2 SDRAM Modules

- 13) The  $t_{HZ}$ ,  $t_{RPST}$  and  $t_{LZ}$ ,  $t_{RPRE}$  parameters are referenced to a specific voltage level, which specify when the device output is no longer driving ( $t_{HZ}$ ,  $t_{RPST}$ ), or begins driving ( $t_{LZ}$ ,  $t_{RPRE}$ ).  $t_{HZ}$  and  $t_{LZ}$  transitions occur in the same access time windows as valid data transitions. These parameters are verified by design and characterization, but not subject to production test.
- 14) The Auto-Refresh command interval has been reduced to 3.9  $\mu$ s when operating the DDR2 DRAM in a temperature range between 85 °C and 95 °C.
- 15)  $0\text{ }^{\circ}\text{C} \leq T_{\text{CASE}} \leq 85\text{ }^{\circ}\text{C}$
- 16)  $85\text{ }^{\circ}\text{C} < T_{\text{CASE}} \leq 95\text{ }^{\circ}\text{C}$
- 17) A maximum of eight Auto-Refresh commands can be posted to any given DDR2 SDRAM device.
- 18) The  $t_{RRD}$  timing parameter depends on the page size of the DRAM organization. See **Table 2 “Ordering Information for RoHS Compliant Products” on Page 4.**
- 19) The maximum limit for the  $t_{WPST}$  parameter is not a device limit. The device operates with a greater value for this parameter, but system performance (bus turnaround) degrades accordingly.
- 20) WR must be programmed to fulfill the minimum requirement for the  $t_{WR}$  timing parameter, where  $WR_{\text{MIN}}[\text{cycles}] = t_{WR}(\text{ns})/t_{\text{CK}}(\text{ns})$  rounded up to the next integer value.  $t_{\text{DAL}} = WR + (t_{\text{RP}}/t_{\text{CK}})$ . For each of the terms, if not already an integer, round to the next highest integer.  $t_{\text{CK}}$  refers to the application clock period. WR refers to the WR parameter stored in the MRS.
- 21) Minimum  $t_{\text{WTR}}$  is two clocks when operating the DDR2-SDRAM at frequencies  $\leq 200$  MHz.
- 22) User can choose two different active power-down modes for additional power saving via MRS address bit A12. In “standard active power-down mode” (MR, A12 = “0”) a fast power-down exit timing  $t_{\text{XARD}}$  can be used. In “low active power-down mode” (MR, A12 = “1”) a slow power-down exit timing  $t_{\text{XARDS}}$  has to be satisfied.



**TABLE 15**  
**DRAM Component Timing Parameter by Speed Grade - DDR2-400**

Parameter	Symbol	DDR2-400		Unit	Note 1)2)3)4)5)6)7)
		Min.	Max.		
DQ output access time from CK / $\overline{\text{CK}}$	$t_{AC}$	-600	+600	ps	
CAS A to CAS B command period	$t_{CCD}$	2	—	$t_{CK}$	
CK, $\overline{\text{CK}}$ high-level width	$t_{CH}$	0.45	0.55	$t_{CK}$	
CKE minimum high and low pulse width	$t_{CKE}$	3	—	$t_{CK}$	
CK, $\overline{\text{CK}}$ low-level width	$t_{CL}$	0.45	0.55	$t_{CK}$	
Auto-Precharge write recovery + precharge time	$t_{DAL}$	WR + $t_{RP}$	—	$t_{CK}$	8)22)
Minimum time clocks remain ON after CKE asynchronously drops LOW	$t_{DELAY}$	$t_{IS} + t_{CK} + t_{IH}$	—	ns	9)
DQ and DM input hold time (differential data strobe)	$t_{DH}(\text{base})$	275	—	ps	10)
DQ and DM input hold time (single ended data strobe)	$t_{DH1}(\text{base})$	-25	—	ps	11)
DQ and DM input pulse width (each input)	$t_{DIPW}$	0.35	—	$t_{CK}$	
DQS output access time from CK / $\overline{\text{CK}}$	$t_{DQSQ}$	-500	+500	ps	
DQS input low (high) pulse width (write cycle)	$t_{DQSL,H}$	0.35	—	$t_{CK}$	
DQS-DQ skew (for DQS & associated DQ signals)	$t_{DQSQ}$	—	350	ps	11)
Write command to 1st DQS latching transition	$t_{DQSS}$	- 0.25	+ 0.25	$t_{CK}$	
DQ and DM input setup time (differential data strobe)	$t_{DS}(\text{base})$	150	—	ps	11)
DQ and DM input setup time (single ended data strobe)	$t_{DS1}(\text{base})$	-25	—	ps	11)
DQS falling edge hold time from CK (write cycle)	$t_{DSH}$	0.2	—	$t_{CK}$	
DQS falling edge to CK setup time (write cycle)	$t_{DSS}$	0.2	—	$t_{CK}$	
Clock half period	$t_{HP}$	MIN. ( $t_{CL}, t_{CH}$ )		—	12)
Data-out high-impedance time from CK / $\overline{\text{CK}}$	$t_{HZ}$	—	$t_{AC,MAX}$	ps	13)
Address and control input hold time	$t_{IH}(\text{base})$	475	—	ps	11)
Address and control input pulse width (each input)	$t_{IPW}$	0.6	—	$t_{CK}$	
Address and control input setup time	$t_{IS}(\text{base})$	350	—	ps	11)
DQ low-impedance time from CK / $\overline{\text{CK}}$	$t_{LZ}(\text{DQ})$	$2 \times t_{AC,MIN}$	$t_{AC,MAX}$	ps	14)
DQS low-impedance from CK / $\overline{\text{CK}}$	$t_{LZ}(\text{DQS})$	$t_{AC,MIN}$	$t_{AC,MAX}$	ps	14)
Mode register set command cycle time	$t_{MRD}$	2	—	$t_{CK}$	
OCD drive mode output delay	$t_{OIT}$	0	12	ns	
Data output hold time from DQS	$t_{QH}$	$t_{HP} - t_{QHS}$	—	—	
Data hold skew factor	$t_{QHS}$	—	450	ps	



HYS64T[32/64]0[0/2]0HM-[3S/3.7/5]-A  
Micro-DIMM DDR2 SDRAM Modules

Parameter	Symbol	DDR2-400		Unit	Note 1)2)3)4)5)6)7)
		Min.	Max.		
Average periodic refresh Interval	$t_{REFI}$	—	7.8	$\mu\text{S}$	14)15)
		—	3.9	$\mu\text{S}$	16)18)
Auto-Refresh to Active/Auto-Refresh command period		105	—	ns	17)
Precharge-All (4 banks) command period	$t_{RP}$	$t_{RP} + 1t_{CK}$	—	ns	
Precharge-All (8 banks) command period	$t_{RP}$	$15 + 1t_{CK}$	—	ns	
Read preamble	$t_{RPRE}$	0.9	1.1	$t_{CK}$	14)
Read postamble	$t_{RPST}$	0.40	0.60	$t_{CK}$	14)
Active bank A to Active bank B command period	$t_{RRD}$	7.5	—	ns	14)18)
		10	—	ns	16)20)
Internal Read to Precharge command delay	$t_{RTP}$	7.5	—	ns	
Write preamble	$t_{WPRE}$	0.25	—	$t_{CK}$	
Write postamble	$t_{WPST}$	0.40	0.60	$t_{CK}$	19)
Write recovery time for write without Auto-Precharge	$t_{WR}$	15	—	ns	
Write recovery time for write with Auto-Precharge	WR	$t_{WR}/t_{CK}$	—	$t_{CK}$	20)
Internal Write to Read command delay	$t_{WTR}$	10	—	ns	21)
Exit power down to any valid command (other than NOP or Deselect)	$t_{XARD}$	2	—	$t_{CK}$	22)
Exit active power-down mode to Read command (slow exit, lower power)	$t_{XARDS}$	6 – AL	—	$t_{CK}$	22)
Exit precharge power-down to any valid command (other than NOP or Deselect)	$t_{XP}$	2	—	$t_{CK}$	
Exit Self-Refresh to non-Read command	$t_{XSNR}$	$t_{RFC} + 10$	—	ns	
Exit Self-Refresh to Read command	$t_{XSRD}$	200	—	$t_{CK}$	

- 1) For details and notes see the relevant Qimonda component data sheet
- 2)  $V_{DDQ} = 1.8 \text{ V} \pm 0.1 \text{ V}$ ;  $V_{DD} = 1.8 \text{ V} \pm 0.1 \text{ V}$ . See notes 5)6)7)8)
- 3) Timing that is not specified is illegal and after such an event, in order to guarantee proper operation, the DRAM must be powered down and then restarted through the specified initialization sequence before normal operation can continue.
- 4) Timings are guaranteed with  $\text{CK}/\overline{\text{CK}}$  differential Slew Rate of 2.0 V/ns. For DQS signals timings are guaranteed with a differential Slew Rate of 2.0 V/ns in differential strobe mode and a Slew Rate of 1 V/ns in single ended mode.
- 5) The  $\text{CK} / \overline{\text{CK}}$  input reference level (for timing reference to  $\text{CK} / \overline{\text{CK}}$ ) is the point at which  $\text{CK}$  and  $\overline{\text{CK}}$  cross. The  $\text{DQS} / \overline{\text{DQS}}$ ,  $\text{RDQS} / \overline{\text{RDQS}}$ , input reference level is the crosspoint when in differential strobe mode.
- 6) Inputs are not recognized as valid until  $V_{REF}$  stabilizes. During the period before  $V_{REF}$  stabilizes,  $\text{CKE} = 0.2 \times V_{DDQ}$  is recognized as low.
- 7) The output timing reference voltage level is  $V_{TT}$ .
- 8) For each of the terms, if not already an integer, round to the next highest integer.  $t_{CK}$  refers to the application clock period. WR refers to the WR parameter stored in the MR.
- 9) The clock frequency is allowed to change during self-refresh mode or precharge power-down mode.
- 10) For timing definition, refer to the Component data sheet.
- 11) Consists of data pin skew and output pattern effects, and p-channel to n-channel variation of the output drivers as well as output Slew Rate mis-match between  $\text{DQS} / \overline{\text{DQS}}$  and associated DQ in any given cycle.
- 12) MIN ( $t_{CL}$ ,  $t_{CH}$ ) refers to the smaller of the actual clock low time and the actual clock high time as provided to the device (i.e. this value can be greater than the minimum specification limits for  $t_{CL}$  and  $t_{CH}$ ).



HYS64T[32/64]0[0/2]0HM-[3S/3.7/5]-A  
Micro-DIMM DDR2 SDRAM Modules

- 13) The  $t_{HZ}$ ,  $t_{RPST}$  and  $t_{LZ}$ ,  $t_{RPRE}$  parameters are referenced to a specific voltage level, which specify when the device output is no longer driving ( $t_{HZ}$ ,  $t_{RPST}$ ), or begins driving ( $t_{LZ}$ ,  $t_{RPRE}$ ).  $t_{HZ}$  and  $t_{LZ}$  transitions occur in the same access time windows as valid data transitions. These parameters are verified by design and characterization, but not subject to production test.
- 14) The Auto-Refresh command interval has been reduced to 3.9  $\mu$ s when operating the DDR2 DRAM in a temperature range between 85 °C and 95 °C.
- 15)  $0\text{ }^{\circ}\text{C} \leq T_{\text{CASE}} \leq 85\text{ }^{\circ}\text{C}$
- 16)  $85\text{ }^{\circ}\text{C} < T_{\text{CASE}} \leq 95\text{ }^{\circ}\text{C}$
- 17) A maximum of eight Auto-Refresh commands can be posted to any given DDR2 SDRAM device.
- 18) The  $t_{RRD}$  timing parameter depends on the page size of the DRAM organization. See **Table 2 “Ordering Information for RoHS Compliant Products” on Page 4.**
- 19) The maximum limit for the  $t_{WPST}$  parameter is not a device limit. The device operates with a greater value for this parameter, but system performance (bus turnaround) degrades accordingly.
- 20) WR must be programmed to fulfill the minimum requirement for the  $t_{WR}$  timing parameter, where  $WR_{\text{MIN}}[\text{cycles}] = t_{WR}(\text{ns})/t_{\text{CK}}(\text{ns})$  rounded up to the next integer value.  $t_{\text{DAL}} = WR + (t_{\text{RP}}/t_{\text{CK}})$ . For each of the terms, if not already an integer, round to the next highest integer.  $t_{\text{CK}}$  refers to the application clock period. WR refers to the WR parameter stored in the MRS.
- 21) Minimum  $t_{\text{WTR}}$  is two clocks when operating the DDR2-SDRAM at frequencies  $\leq 200$  MHz.
- 22) User can choose two different active power-down modes for additional power saving via MRS address bit A12. In “standard active power-down mode” (MR, A12 = “0”) a fast power-down exit timing  $t_{\text{XARD}}$  can be used. In “low active power-down mode” (MR, A12 = “1”) a slow power-down exit timing  $t_{\text{XARDS}}$  has to be satisfied.



### 3.3.3 ODT AC Electrical Characteristics

This chapter contains the ODT AC electrical characteristic tables.

**TABLE 16**  
ODT AC Character. and Operating Conditions for DDR2-667

Symbol	Parameter / Condition	Values		Unit	Note
		Min.	Max.		
$t_{AOND}$	ODT turn-on delay	2	2	nCK	1)
$t_{AON}$	ODT turn-on	$t_{AC,MIN}$	$t_{AC,MAX} + 0.7 \text{ ns}$	ns	1)2)
$t_{AONPD}$	ODT turn-on (Power-Down Modes)	$t_{AC,MIN} + 2 \text{ ns}$	$2 t_{CK} + t_{AC,MAX} + 1 \text{ ns}$	ns	1)
$t_{AOFD}$	ODT turn-off delay	2.5	2.5	nCK	1)
$t_{AOF}$	ODT turn-off	$t_{AC,MIN}$	$t_{AC,MAX} + 0.6 \text{ ns}$	ns	1)3)
$t_{AOFPD}$	ODT turn-off (Power-Down Modes)	$t_{AC,MIN} + 2 \text{ ns}$	$2.5 t_{CK} + t_{AC,MAX} + 1 \text{ ns}$	ns	1)
$t_{ANPD}$	ODT to Power Down Mode Entry Latency	3	—	nCK	1)
$t_{AXPD}$	ODT Power Down Exit Latency	8	—	nCK	1)

- 1) New units, ' $t_{CK,AVG}$ ' and 'nCK', are introduced in DDR2-667 and DDR2-800. Unit ' $t_{CK,AVG}$ ' represents the actual  $t_{CK,AVG}$  of the input clock under operation. Unit 'nCK' represents one clock cycle of the input clock, counting the actual clock edges. Note that in DDR2-400 and DDR2-533, ' $t_{CK}$ ' is used for both concepts. Example:  $t_{XP} = 2 \text{ [nCK]}$  means; if Power Down exit is registered at  $T_m$ , an Active command may be registered at  $T_m + 2$ , even if  $(T_m + 2 - T_m)$  is  $2 \times t_{CK,AVG} + t_{EPR,2PER(MIN)}$ .
- 2) ODT turn on time min is when the device leaves high impedance and ODT resistance begins to turn on. ODT turn on time max is when the ODT resistance is fully on. Both are measured from  $t_{AOND}$ , which is interpreted differently per speed bin. For DDR2-667/800,  $t_{AOND}$  is 2 clock cycles after the clock edge that registered a first ODT HIGH counting the actual input clock edges.
- 3) ODT turn off time min. is when the device starts to turn off ODT resistance. ODT turn off time max is when the bus is in high impedance. Both are measured from  $t_{AOFD}$ . Both are measured from  $t_{AOFD}$ , which is interpreted differently per speed bin. For DDR2-667/800, if  $t_{CK,AVG} = 3 \text{ ns}$  is assumed,  $t_{AOFD} = 1.5 \text{ ns}$  ( $0.5 \times 3 \text{ ns}$ ) after the second trailing clock edge counting from the clock edge that registered a first ODT LOW and by counting the actual input clock edge.



HYS64T[32/64]0[0/2]0HM-[3S/3.7/5]-A  
Micro-DIMM DDR2 SDRAM Modules

**TABLE 17**  
**ODT AC Character. and Operating Conditions for DDR2-533 & DDR2-400**

Symbol	Parameter / Condition	Values		Unit	Note
		Min.	Max.		
$t_{AOND}$	ODT turn-on delay	2	2	$t_{CK}$	
$t_{AON}$	ODT turn-on	$t_{AC.MIN}$	$t_{AC.MAX} + 1 \text{ ns}$	ns	1)
$t_{AONPD}$	ODT turn-on (Power-Down Modes)	$t_{AC.MIN} + 2 \text{ ns}$	$2 t_{CK} + t_{AC.MAX} + 1 \text{ ns}$	ns	
$t_{AOFD}$	ODT turn-off delay	2.5	2.5	$t_{CK}$	
$t_{AOF}$	ODT turn-off	$t_{AC.MIN}$	$t_{AC.MAX} + 0.6 \text{ ns}$	ns	2)
$t_{AOFPD}$	ODT turn-off (Power-Down Modes)	$t_{AC.MIN} + 2 \text{ ns}$	$2.5 t_{CK} + t_{AC.MAX} + 1 \text{ ns}$	ns	
$t_{ANPD}$	ODT to Power Down Mode Entry Latency	3	—	$t_{CK}$	
$t_{AXPD}$	ODT Power Down Exit Latency	8	—	$t_{CK}$	

- 1) ODT turn on time min is when the device leaves high impedance and ODT resistance begins to turn on. ODT turn on time max is when the ODT resistance is fully on. Both are measured from  $t_{AOND}$ , which is interpreted differently per speed bin. For DDR2-400/533,  $t_{AOND}$  is 10 ns (= 2 x 5 ns) after the clock edge that registered a first ODT HIGH if  $t_{CK} = 5 \text{ ns}$ .
- 2) ODT turn off time min. is when the device starts to turn off ODT resistance. ODT turn off time max is when the bus is in high impedance. Both are measured from  $t_{AOFD}$ . Both are measured from  $t_{AOFD}$ , which is interpreted differently per speed bin. For DDR2-400/533,  $t_{AOFD}$  is 12.5 ns (= 2.5 x 5 ns) after the clock edge that registered a first ODT HIGH if  $t_{CK} = 5 \text{ ns}$ .



### 3.4 $I_{DD}$ Specifications and Conditions

This chapter describes the  $I_{DD}$  Specifications and Conditions.

**TABLE 18**  
 **$I_{DD}$  Measurement Conditions**

Parameter	Symbol	Note 1)2)3)4)5)
<b>Operating Current 0</b> One bank Active - Precharge; $t_{CK} = t_{CK,MIN}$ , $t_{RC} = t_{RC,MIN}$ , $t_{RAS} = t_{RAS,MIN}$ , CKE is HIGH, $\overline{CS}$ is HIGH between valid commands. Address and control inputs are SWITCHING, Databus inputs are SWITCHING.	$I_{DD0}$	
<b>Operating Current 1</b> One bank Active - Read - Precharge; $I_{OUT} = 0$ mA, $BL = 4$ , $t_{CK} = t_{CK,MIN}$ , $t_{RC} = t_{RC,MIN}$ , $t_{RAS} = t_{RAS,MIN}$ , $t_{RCD} = t_{RCD,MIN}$ , $AL = 0$ , $CL = CL_{MIN}$ ; CKE is HIGH, $\overline{CS}$ is HIGH between valid commands. Address and control inputs are SWITCHING, Databus inputs are SWITCHING.	$I_{DD1}$	6)
<b>Precharge Standby Current</b> All banks idle; $\overline{CS}$ is HIGH; CKE is HIGH; $t_{CK} = t_{CK,MIN}$ ; Other control and address inputs are SWITCHING, Databus inputs are SWITCHING.	$I_{DD2N}$	
<b>Precharge Power-Down Current</b> Other control and address inputs are STABLE, Data bus inputs are FLOATING.	$I_{DD2P}$	
<b>Precharge Quiet Standby Current</b> All banks idle; $\overline{CS}$ is HIGH; CKE is HIGH; $t_{CK} = t_{CK,MIN}$ ; Other control and address inputs are STABLE, Data bus inputs are FLOATING.	$I_{DD2Q}$	
<b>Active Standby Current</b> Burst Read: All banks open; Continuous burst reads; $BL = 4$ ; $AL = 0$ , $CL = CL_{MIN}$ ; $t_{CK} = t_{CK,MIN}$ ; $t_{RAS} = t_{RAS,MAX}$ , $t_{RP} = t_{RP,MIN}$ ; CKE is HIGH, $\overline{CS}$ is HIGH between valid commands. Address inputs are SWITCHING; Data Bus inputs are SWITCHING; $I_{OUT} = 0$ mA.	$I_{DD3N}$	
<b>Active Power-Down Current</b> All banks open; $t_{CK} = t_{CK,MIN}$ , CKE is LOW; Other control and address inputs are STABLE, Data bus inputs are FLOATING. MRS A12 bit is set to LOW (Fast Power-down Exit);	$I_{DD3P(0)}$	
<b>Active Power-Down Current</b> All banks open; $t_{CK} = t_{CK,MIN}$ , CKE is LOW; Other control and address inputs are STABLE, Data bus inputs are FLOATING. MRS A12 bit is set to HIGH (Slow Power-down Exit);	$I_{DD3P(1)}$	
<b>Operating Current - Burst Read</b> All banks open; Continuous burst reads; $BL = 4$ ; $AL = 0$ , $CL = CL_{MIN}$ ; $t_{CK} = t_{CK,MIN}$ ; $t_{RAS} = t_{RAS,MAX}$ ; $t_{RP} = t_{RP,MIN}$ ; CKE is HIGH, $\overline{CS}$ is HIGH between valid commands; Address inputs are SWITCHING; Data bus inputs are SWITCHING; $I_{OUT} = 0$ mA.	$I_{DD4R}$	6)
<b>Operating Current - Burst Write</b> All banks open; Continuous burst writes; $BL = 4$ ; $AL = 0$ , $CL = CL_{MIN}$ ; $t_{CK} = t_{CK,MIN}$ ; $t_{RAS} = t_{RAS,MAX}$ , $t_{RP} = t_{RP,MAX}$ ; CKE is HIGH, $\overline{CS}$ is HIGH between valid commands. Address inputs are SWITCHING; Data Bus inputs are SWITCHING;	$I_{DD4W}$	
<b>Burst Refresh Current</b> $t_{CK} = t_{CK,MIN}$ , Refresh command every $t_{RFC} = t_{RFC,MIN}$ interval, CKE is HIGH, $\overline{CS}$ is HIGH between valid commands, Other control and address inputs are SWITCHING, Data bus inputs are SWITCHING.	$I_{DD5B}$	
<b>Distributed Refresh Current</b> $t_{CK} = t_{CK,MIN}$ , Refresh command every $t_{RFC} = t_{REFI}$ interval, CKE is LOW and $\overline{CS}$ is HIGH between valid commands, Other control and address inputs are SWITCHING, Data bus inputs are SWITCHING.	$I_{DD5D}$	



HYS64T[32/64]0[0/2]0HM-[3S/3.7/5]-A  
Micro-DIMM DDR2 SDRAM Modules

Parameter	Symbol	Note 1)2)3)4)5)
<b>Self-Refresh Current</b> CKE $\leq$ 0.2 V; external clock off, CK and $\overline{\text{CK}}$ at 0 V; Other control and address inputs are FLOATING, Data bus inputs are FLOATING. $I_{\text{DD6}}$ current values are guaranteed up to $T_{\text{CASE}}$ of 85 °C max.	$I_{\text{DD6}}$	
<b>All Bank Interleave Read Current</b> All banks are being interleaved at minimum $t_{\text{RC}}$ without violating $t_{\text{RRD}}$ using a burst length of 4. Control and address bus inputs are STABLE during DESELECTS. $I_{\text{out}} = 0$ mA.	$I_{\text{DD7}}$	6)

- 1)  $V_{\text{DDQ}} = 1.8 \text{ V} \pm 0.1 \text{ V}$ ;  $V_{\text{DD}} = 1.8 \text{ V} \pm 0.1 \text{ V}$
- 2)  $I_{\text{DD}}$  specifications are tested after the device is properly initialized and  $I_{\text{DD}}$  parameter are specified with ODT disabled.
- 3) Definitions for  $I_{\text{DD}}$  see **Table 19**
- 4) For two rank modules: for all active current measurements the other rank is in Precharge Power-Down Mode  $I_{\text{DD2P}}$
- 5) For details and notes see the relevant Qimonda component data sheet
- 6)  $I_{\text{DD1}}$ ,  $I_{\text{DD4R}}$  and  $I_{\text{DD7}}$  current measurements are defined with the outputs disabled ( $I_{\text{OUT}} = 0$  mA). To achieve this on module level the output buffers can be disabled using an EMRS(1) (Extended Mode Register Command) by setting A12 bit to HIGH.

**TABLE 19**  
Definitions for  $I_{\text{DD}}$

Parameter	Description
LOW	$V_{\text{IN}} \leq V_{\text{IL(ac).MAX}}$ , HIGH is defined as $V_{\text{IN}} \geq V_{\text{IH(ac).MIN}}$
STABLE	Inputs are stable at a HIGH or LOW level
FLOATING	Inputs are $V_{\text{REF}} = V_{\text{DDQ}} / 2$
SWITCHING	Inputs are changing between HIGH and LOW every other clock (once per 2 cycles) for address and control signals, and inputs changing between HIGH and LOW every other data transfer (once per cycle) for DQ signals not including mask or strobes



HYS64T[32/64]0[0/2]0HM-[3S/3.7/5]-A  
Micro-DIMM DDR2 SDRAM Modules

**TABLE 20**

**$I_{DD}$  Specification for HYS64T[32000/64020]HM-3S-A**

Product Type	HYS64T32000HM-3S-A	HYS64T64020HM-3S-A	Unit	Note <sup>1)</sup>
<b>Organization</b>	<b>256MB</b>	<b>512MB</b>		
	<b>1 Rank</b>	<b>2 Ranks</b>		
	<b>×64</b>	<b>×64</b>		
	<b>-3S</b>	<b>-3S</b>		
<b>Symbol</b>	<b>Max.</b>	<b>Max.</b>		
$I_{DD0}$	360	380	mA	2)
$I_{DD1}$	420	440	mA	2)
$I_{DD2N}$	200	400	mA	3)
$I_{DD2P}$	20	40	mA	3)
$I_{DD2Q}$	160	320	mA	3)
$I_{DD3N}$	200	400	mA	3)
$I_{DD3P}(MRS = 0)$	80	150	mA	3)
$I_{DD3P}(MRS = 1)$	20	50	mA	3)
$I_{DD4R}$	600	620	mA	2)
$I_{DD4W}$	680	700	mA	2)
$I_{DD5B}$	560	580	mA	2)
$I_{DD5D}$	20	50	mA	3)4)
$I_{DD6}$	20	40	mA	3)4)
$I_{DD7}$	910	930	mA	2)

- 1) Calculated values from component data. ODT disabled.  $I_{DD1}$ ,  $I_{DD4R}$  and  $I_{DD7}$  are defined with the outputs disabled
- 2) The other rank is in  $I_{DD2P}$  Precharge Power-Down Standby Current mode
- 3) Both ranks are in the same  $I_{DD}$  mode
- 4) Values for  $0\text{ °C} \leq T_{CASE} \leq 85\text{ °C}$



HYS64T[32/64]0[0/2]0HM-[3S/3.7/5]-A  
Micro-DIMM DDR2 SDRAM Modules

**TABLE 21**

**$I_{DD}$  Specification for HYS64T[32000/64020]HM-3.7-A**

Product Type	HYS64T32000HM-3.7-A	HYS64T64020HM-3.7-A	Unit	Note <sup>1)</sup>
<b>Organization</b>	256 MB	512 MB		
	1 Rank	2 Ranks		
	×64	×64		
	-3.7	-3.7		
<b>Symbol</b>	<b>Max.</b>	<b>Max.</b>		
$I_{DD0}$	320	340	mA	2)
$I_{DD1}$	360	380	mA	2)
$I_{DD2N}$	160	320	mA	3)
$I_{DD2P}$	20	30	mA	3)
$I_{DD2Q}$	120	240	mA	3)
$I_{DD3N}$	160	320	mA	3)
$I_{DD3P}$ ( MRS = 0)	60	130	mA	3)
$I_{DD3P}$ ( MRS = 1)	20	40	mA	3)
$I_{DD4R}$	400	420	mA	2)
$I_{DD4W}$	440	460	mA	2)
$I_{DD5B}$	520	540	mA	2)
$I_{DD5D}$	20	50	mA	3)4)
$I_{DD6}$	16	32	mA	3)4)
$I_{DD7}$	880	900	mA	2)

- 1) Calculated values from component data. ODT disabled.  $I_{DD1}$ ,  $I_{DD4R}$  and  $I_{DD7}$  are defined with the outputs disabled
- 2) The other rank is in  $I_{DD2P}$  Precharge Power-Down Standby Current mode
- 3) Both ranks are in the same  $I_{DD}$  mode
- 4) Values for  $0\text{ }^{\circ}\text{C} \leq T_{\text{CASE}} \leq 85\text{ }^{\circ}\text{C}$



HYS64T[32/64]0[0/2]0HM-[3S/3.7/5]-A  
Micro-DIMM DDR2 SDRAM Modules

**TABLE 22**

$I_{DD}$  Specification for HYS64T[32000/64020]HM-5-A

Product Type	HYS64T32000HM-5-A	HYS64T64020HM-5-A	Unit	Note <sup>1)</sup>
<b>Organization</b>	<b>256 MB</b>	<b>512 MB</b>		
	<b>1 Rank</b>	<b>2 Ranks</b>		
	<b>×64</b>	<b>×64</b>		
	<b>-5</b>	<b>-5</b>		
<b>Symbol</b>	<b>Max.</b>	<b>Max.</b>		
$I_{DD0}$	280	300	mA	2)
$I_{DD1}$	300	320	mA	2)
$I_{DD2N}$			mA	3)
$I_{DD2P}$	20	30	mA	3)
$I_{DD2Q}$	100	200	mA	3)
$I_{DD3N}$	140	280	mA	3)
$I_{DD3P}(MRS = 0)$	50	100	mA	3)
$I_{DD3P}(MRS = 1)$	20	40	mA	3)
$I_{DD4R}$	340	360	mA	2)
$I_{DD4W}$	360	380	mA	2)
$I_{DD5B}$	480	500	mA	2)
$I_{DD5D}$	20	50	mA	3)4)
$I_{DD6}$	16	32	mA	3)4)
$I_{DD7}$	840	860	mA	2)

- 1) Calculated values from component data. ODT disabled.  $I_{DD1}$ ,  $I_{DD4R}$  and  $I_{DD7}$  are defined with the outputs disabled
- 2) The other rank is in  $I_{DD2P}$  Precharge Power-Down Standby Current mode
- 3) Both ranks are in the same  $I_{DD}$  mode
- 4) Values for  $0\text{ °C} \leq T_{CASE} \leq 85\text{ °C}$





# 4 SPD Codes

This chapter lists all hexadecimal byte values stored in the EEPROM of the products described in this data sheet. SPD stands for serial presence detect. All values with XX in the table are module specific bytes which are defined during production.

### List of SPD Code Tables

- Table 23 “SPD codes for HYS64T[32/64]0[0/2]0HM-[3S/3.7/5]-A” on Page 33

		<b>TABLE 23</b>					
		<b>SPD codes for HYS64T[32/64]0[0/2]0HM-[3S/3.7/5]-A</b>					
<b>Product Type</b>		<b>HYS64T32000HM-3S-A</b>	<b>HYS64T64020HM-3S-A</b>	<b>HYS64T32000HM-3.7-A</b>	<b>HYS64T64020HM-3.7-A</b>	<b>HYS64T32000HM-5-A</b>	<b>HYS64T64020HM-5-A</b>
<b>Organization</b>		<b>256MB</b>	<b>512MB</b>	<b>256MB</b>	<b>512MB</b>	<b>256MB</b>	<b>512MB</b>
		<b>×64</b>	<b>×64</b>	<b>×64</b>	<b>×64</b>	<b>×64</b>	<b>×64</b>
		<b>1 Rank (×16)</b>	<b>2 Ranks (×16)</b>	<b>1 Rank (×16)</b>	<b>2 Ranks (×16)</b>	<b>1 Rank (×16)</b>	<b>2 Ranks (×16)</b>
<b>Label Code</b>		<b>PC2-5300M-555</b>	<b>PC2-5300M-555</b>	<b>PC2-4200M-444</b>	<b>PC2-4200M-444</b>	<b>PC2-3200M-333</b>	<b>PC2-3200M-333</b>
<b>JEDEC SPD Revision</b>		<b>Rev. 1.2</b>	<b>Rev. 1.2</b>	<b>Rev. 1.1</b>	<b>Rev. 1.1</b>	<b>Rev. 1.1</b>	<b>Rev. 1.1</b>
<b>Byte#</b>	<b>Description</b>	<b>HEX</b>	<b>HEX</b>	<b>HEX</b>	<b>HEX</b>	<b>HEX</b>	<b>HEX</b>
0	Programmed SPD Bytes in EEPROM	80	80	80	80	80	80
1	Total number of Bytes in EEPROM	08	08	08	08	08	08
2	Memory Type (DDR2)	08	08	08	08	08	08
3	Number of Row Addresses	0D	0D	0D	0D	0D	0D
4	Number of Column Addresses	0A	0A	0A	0A	0A	0A
5	DIMM Rank and Stacking Information	60	61	60	61	60	61
6	Data Width	40	40	40	40	40	40
7	Not used	00	00	00	00	00	00
8	Interface Voltage Level	05	05	05	05	05	05
9	$t_{CK} @ CL_{MAX}$ (Byte 18) [ns]	30	30	3D	3D	50	50



HYS64T[32/64]0[0/2]0HM-[3S/3.7/5]-A  
Micro-DIMM DDR2 SDRAM Modules

Product Type		HYS64T32000HM-3S-A	HYS64T64020HM-3S-A	HYS64T32000HM-3.7-A	HYS64T64020HM-3.7-A	HYS64T32000HM-5-A	HYS64T64020HM-5-A
Organization		256MB	512MB	256MB	512MB	256MB	512MB
		×64	×64	×64	×64	×64	×64
		1 Rank (×16)	2 Ranks (×16)	1 Rank (×16)	2 Ranks (×16)	1 Rank (×16)	2 Ranks (×16)
Label Code		PC2-5300M-555	PC2-5300M-555	PC2-4200M-444	PC2-4200M-444	PC2-3200M-333	PC2-3200M-333
JEDEC SPD Revision		Rev. 1.2	Rev. 1.2	Rev. 1.1	Rev. 1.1	Rev. 1.1	Rev. 1.1
Byte#	Description	HEX	HEX	HEX	HEX	HEX	HEX
10	$t_{AC}$ SDRAM @ $CL_{MAX}$ (Byte 18) [ns]	45	45	50	50	60	60
11	Error Correction Support (non-ECC, ECC)	00	00	00	00	00	00
12	Refresh Rate and Type	82	82	82	82	82	82
13	Primary SDRAM Width	10	10	10	10	10	10
14	Error Checking SDRAM Width	00	00	00	00	00	00
15	Not used	00	00	00	00	00	00
16	Burst Length Supported	0C	0C	0C	0C	0C	0C
17	Number of Banks on SDRAM Device	04	04	04	04	04	04
18	Supported CAS Latencies	38	38	38	38	38	38
19	DIMM Mechanical Characteristics	01	01	00	00	00	00
20	DIMM Type Information	08	08	08	08	08	08
21	DIMM Attributes	00	00	00	00	00	00
22	Component Attributes	03	03	01	01	01	01
23	$t_{CK} @ CL_{MAX} -1$ (Byte 18) [ns]	3D	3D	3D	3D	50	50
24	$t_{AC}$ SDRAM @ $CL_{MAX} -1$ [ns]	50	50	50	50	60	60
25	$t_{CK} @ CL_{MAX} -2$ (Byte 18) [ns]	50	50	50	50	50	50
26	$t_{AC}$ SDRAM @ $CL_{MAX} -2$ [ns]	60	60	60	60	60	60
27	$t_{RP,MIN}$ [ns]	3C	3C	3C	3C	3C	3C
28	$t_{RRD,MIN}$ [ns]	28	28	28	28	28	28
29	$t_{RCD,MIN}$ [ns]	3C	3C	3C	3C	3C	3C
30	$t_{RAS,MIN}$ [ns]	2D	2D	2D	2D	28	28



HYS64T[32/64]0[0/2]0HM-[3S/3.7/5]-A  
Micro-DIMM DDR2 SDRAM Modules

Product Type		HYS64T32000HM-3S-A	HYS64T64020HM-3S-A	HYS64T32000HM-3.7-A	HYS64T64020HM-3.7-A	HYS64T32000HM-5-A	HYS64T64020HM-5-A
Organization		256MB	512MB	256MB	512MB	256MB	512MB
		×64	×64	×64	×64	×64	×64
		1 Rank (×16)	2 Ranks (×16)	1 Rank (×16)	2 Ranks (×16)	1 Rank (×16)	2 Ranks (×16)
Label Code		PC2-5300M-555	PC2-5300M-555	PC2-4200M-444	PC2-4200M-444	PC2-3200M-333	PC2-3200M-333
JEDEC SPD Revision		Rev. 1.2	Rev. 1.2	Rev. 1.1	Rev. 1.1	Rev. 1.1	Rev. 1.1
Byte#	Description	HEX	HEX	HEX	HEX	HEX	HEX
31	Module Density per Rank	40	40	40	40	40	40
32	$t_{AS,MIN}$ and $t_{CS,MIN}$ [ns]	20	20	25	25	35	35
33	$t_{AH,MIN}$ and $t_{CH,MIN}$ [ns]	27	27	37	37	47	47
34	$t_{DS,MIN}$ [ns]	10	10	10	10	15	15
35	$t_{DH,MIN}$ [ns]	17	17	22	22	27	27
36	$t_{WR,MIN}$ [ns]	3C	3C	3C	3C	3C	3C
37	$t_{WTR,MIN}$ [ns]	1E	1E	1E	1E	28	28
38	$t_{RTP,MIN}$ [ns]	1E	1E	1E	1E	1E	1E
39	Analysis Characteristics	00	00	00	00	00	00
40	$t_{RC}$ and $t_{RFC}$ Extension	00	00	00	00	00	00
41	$t_{RC,MIN}$ [ns]	3C	3C	3C	3C	37	37
42	$t_{RFC,MIN}$ [ns]	69	69	69	69	69	69
43	$t_{CK,MAX}$ [ns]	80	80	80	80	80	80
44	$t_{DQSQ,MAX}$ [ns]	18	18	1E	1E	23	23
45	$t_{QHS,MAX}$ [ns]	22	22	28	28	2D	2D
46	PLL Relock Time	00	00	00	00	00	00
47	$T_{CASE,MAX}$ Delta / $\Delta T_{4R4W}$ Delta	55	55	53	53	51	51
48	Psi(T-A) DRAM	72	72	72	72	72	72
49	$\Delta T_0$ (DT0)	5F	5F	53	53	43	43
50	$\Delta T_{2N}$ (DT2N, UDIMM) or $\Delta T_{2Q}$ (DT2Q, RDIMM)	36	36	2B	2B	23	23
51	$\Delta T_{2P}$ (DT2P)	24	24	1D	1D	1D	1D
52	$\Delta T_{3N}$ (DT3N)	24	24	1D	1D	19	19
53	$\Delta T_{3P,fast}$ (DT3P fast)	29	29	23	23	1C	1C



HYS64T[32/64]0[0/2]0HM-[3S/3.7/5]-A  
Micro-DIMM DDR2 SDRAM Modules

Product Type		HYS64T32000HM-3S-A	HYS64T64020HM-3S-A	HYS64T32000HM-3.7-A	HYS64T64020HM-3.7-A	HYS64T32000HM-5-A	HYS64T64020HM-5-A
Organization		256MB	512MB	256MB	512MB	256MB	512MB
		×64	×64	×64	×64	×64	×64
		1 Rank (×16)	2 Ranks (×16)	1 Rank (×16)	2 Ranks (×16)	1 Rank (×16)	2 Ranks (×16)
Label Code		PC2-5300M-555	PC2-5300M-555	PC2-4200M-444	PC2-4200M-444	PC2-3200M-333	PC2-3200M-333
JEDEC SPD Revision		Rev. 1.2	Rev. 1.2	Rev. 1.1	Rev. 1.1	Rev. 1.1	Rev. 1.1
Byte#	Description	HEX	HEX	HEX	HEX	HEX	HEX
54	$\Delta T_{3P,slow}$ (DT3P slow)	1A	1A	16	16	16	16
55	$\Delta T_{4R}$ (DT4R) / $\Delta T_{4R4W}$ Sign (DT4R4W)	52	52	36	36	2E	2E
56	$\Delta T_{5B}$ (DT5B)	1E	1E	1C	1C	1A	1A
57	$\Delta T_7$ (DT7)	31	31	30	30	2D	2D
58	Psi(ca) PLL	00	00	00	00	00	00
59	Psi(ca) REG	00	00	00	00	00	00
60	$\Delta T_{PLL}$ (DTPLL)	00	00	00	00	00	00
61	$\Delta T_{REG}$ (DTREG) / Toggle Rate	00	00	00	00	00	00
62	SPD Revision	12	12	11	11	11	11
63	Checksum of Bytes 0-62	D0	D1	C0	C1	08	09
64	Manufacturer's JEDEC ID Code (1)	7F	7F	7F	7F	7F	7F
65	Manufacturer's JEDEC ID Code (2)	7F	7F	7F	7F	7F	7F
66	Manufacturer's JEDEC ID Code (3)	7F	7F	7F	7F	7F	7F
67	Manufacturer's JEDEC ID Code (4)	7F	7F	7F	7F	7F	7F
68	Manufacturer's JEDEC ID Code (5)	7F	7F	7F	7F	7F	7F
69	Manufacturer's JEDEC ID Code (6)	51	51	51	51	51	51
70	Manufacturer's JEDEC ID Code (7)	00	00	00	00	00	00



HYS64T[32/64]0[0/2]0HM-[3S/3.7/5]-A  
Micro-DIMM DDR2 SDRAM Modules

Product Type		HYS64T32000HM-3S-A	HYS64T64020HM-3S-A	HYS64T32000HM-3.7-A	HYS64T64020HM-3.7-A	HYS64T32000HM-5-A	HYS64T64020HM-5-A
Organization		256MB	512MB	256MB	512MB	256MB	512MB
		×64	×64	×64	×64	×64	×64
		1 Rank (×16)	2 Ranks (×16)	1 Rank (×16)	2 Ranks (×16)	1 Rank (×16)	2 Ranks (×16)
Label Code		PC2-5300M-555	PC2-5300M-555	PC2-4200M-444	PC2-4200M-444	PC2-3200M-333	PC2-3200M-333
JEDEC SPD Revision		Rev. 1.2	Rev. 1.2	Rev. 1.1	Rev. 1.1	Rev. 1.1	Rev. 1.1
Byte#	Description	HEX	HEX	HEX	HEX	HEX	HEX
71	Manufacturer's JEDEC ID Code (8)	00	00	00	00	00	00
72	Module Manufacturer Location	xx	xx	xx	xx	xx	xx
73	Product Type, Char 1	36	36	36	36	36	36
74	Product Type, Char 2	34	34	34	34	34	34
75	Product Type, Char 3	54	54	54	54	54	54
76	Product Type, Char 4	33	36	33	36	33	36
77	Product Type, Char 5	32	34	32	34	32	34
78	Product Type, Char 6	30	30	30	30	30	30
79	Product Type, Char 7	30	32	30	32	30	32
80	Product Type, Char 8	30	30	30	30	30	30
81	Product Type, Char 9	48	48	48	48	48	48
82	Product Type, Char 10	4D	4D	4D	4D	4D	4D
83	Product Type, Char 11	33	33	33	33	35	35
84	Product Type, Char 12	53	53	2E	2E	41	41
85	Product Type, Char 13	41	41	37	37	20	20
86	Product Type, Char 14	20	20	41	41	20	20
87	Product Type, Char 15	20	20	20	20	20	20
88	Product Type, Char 16	20	20	20	20	20	20
89	Product Type, Char 17	20	20	20	20	20	20
90	Product Type, Char 18	20	20	20	20	20	20
91	Module Revision Code	3x	3x	5x	5x	5x	5x
92	Test Program Revision Code	xx	xx	xx	xx	xx	xx
93	Module Manufacturing Date Year	xx	xx	xx	xx	xx	xx



HYS64T[32/64]0[0/2]0HM-[3S/3.7/5]-A  
Micro-DIMM DDR2 SDRAM Modules

<b>Product Type</b>		HYS64T32000HM-3S-A	HYS64T64020HM-3S-A	HYS64T32000HM-3.7-A	HYS64T64020HM-3.7-A	HYS64T32000HM-5-A	HYS64T64020HM-5-A
<b>Organization</b>		256MB	512MB	256MB	512MB	256MB	512MB
		×64	×64	×64	×64	×64	×64
		1 Rank (×16)	2 Ranks (×16)	1 Rank (×16)	2 Ranks (×16)	1 Rank (×16)	2 Ranks (×16)
<b>Label Code</b>		PC2-5300M-555	PC2-5300M-555	PC2-4200M-444	PC2-4200M-444	PC2-3200M-333	PC2-3200M-333
<b>JEDEC SPD Revision</b>		Rev. 1.2	Rev. 1.2	Rev. 1.1	Rev. 1.1	Rev. 1.1	Rev. 1.1
<b>Byte#</b>	<b>Description</b>	HEX	HEX	HEX	HEX	HEX	HEX
94	Module Manufacturing Date Week	xx	xx	xx	xx	xx	xx
95 - 98	Module Serial Number	xx	xx	xx	xx	xx	xx
99 - 127	Not used	00	00	00	00	00	00
128 - 255	Blank for customer use	FF	FF	FF	FF	FF	FF



HYS64T[32/64]0[0/2]0HM-[3S/3.7/5]-A  
Micro-DIMM DDR2 SDRAM Modules

## 5 Package Outlines

This chapter contains the package outlines of the products.

**FIGURE 5**  
Package Outline Raw Card A L-DIM-214-1

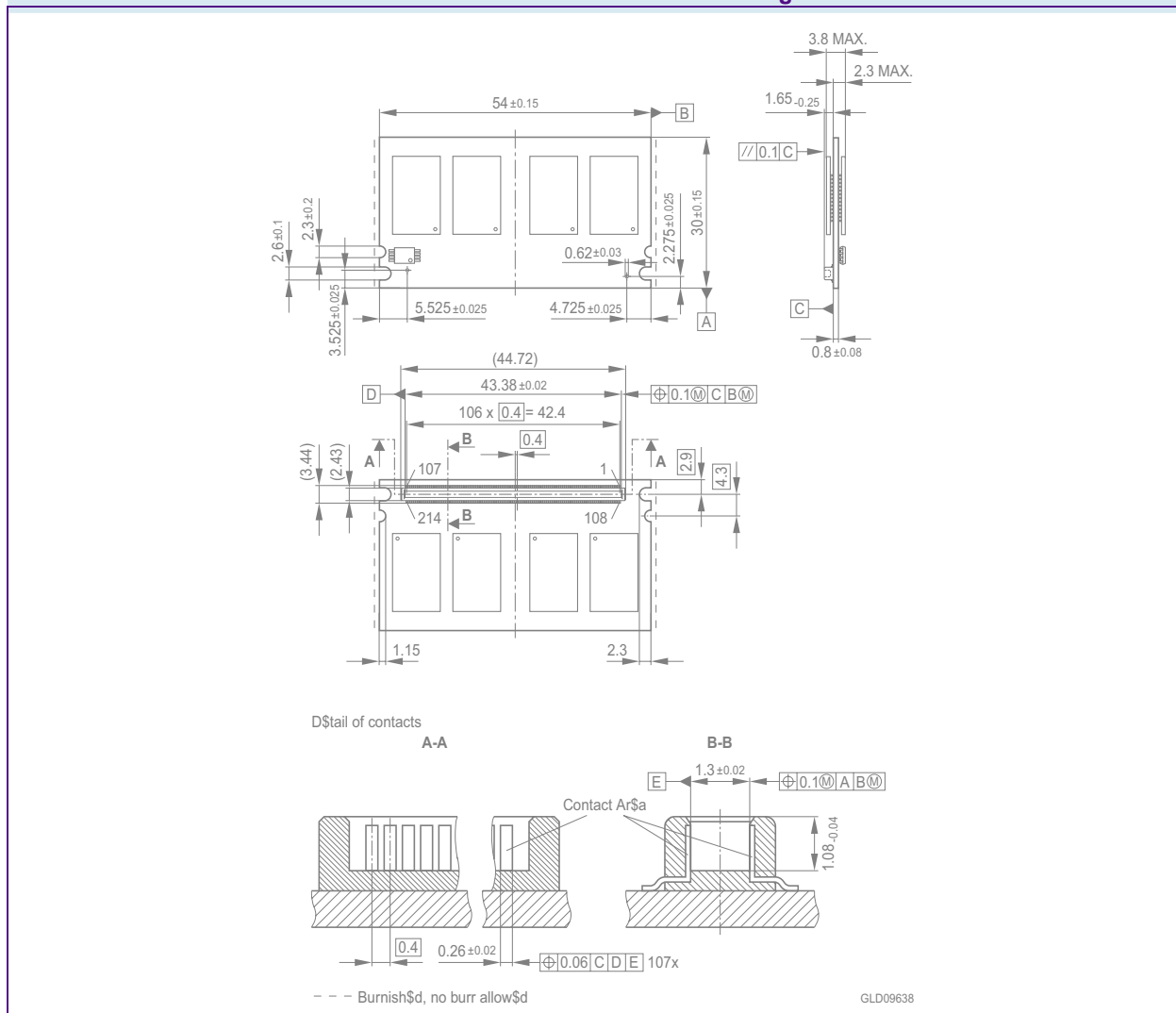

### Notes

1. Drawing according to ISO 8015
2. Dimensions in mm
3. General tolerances +/- 0.15



HYS64T[32/64]0[0/2]0HM-[3S/3.7/5]-A  
Micro-DIMM DDR2 SDRAM Modules

**FIGURE 6**  
Package Outline Raw Card B L-DIM-214-2

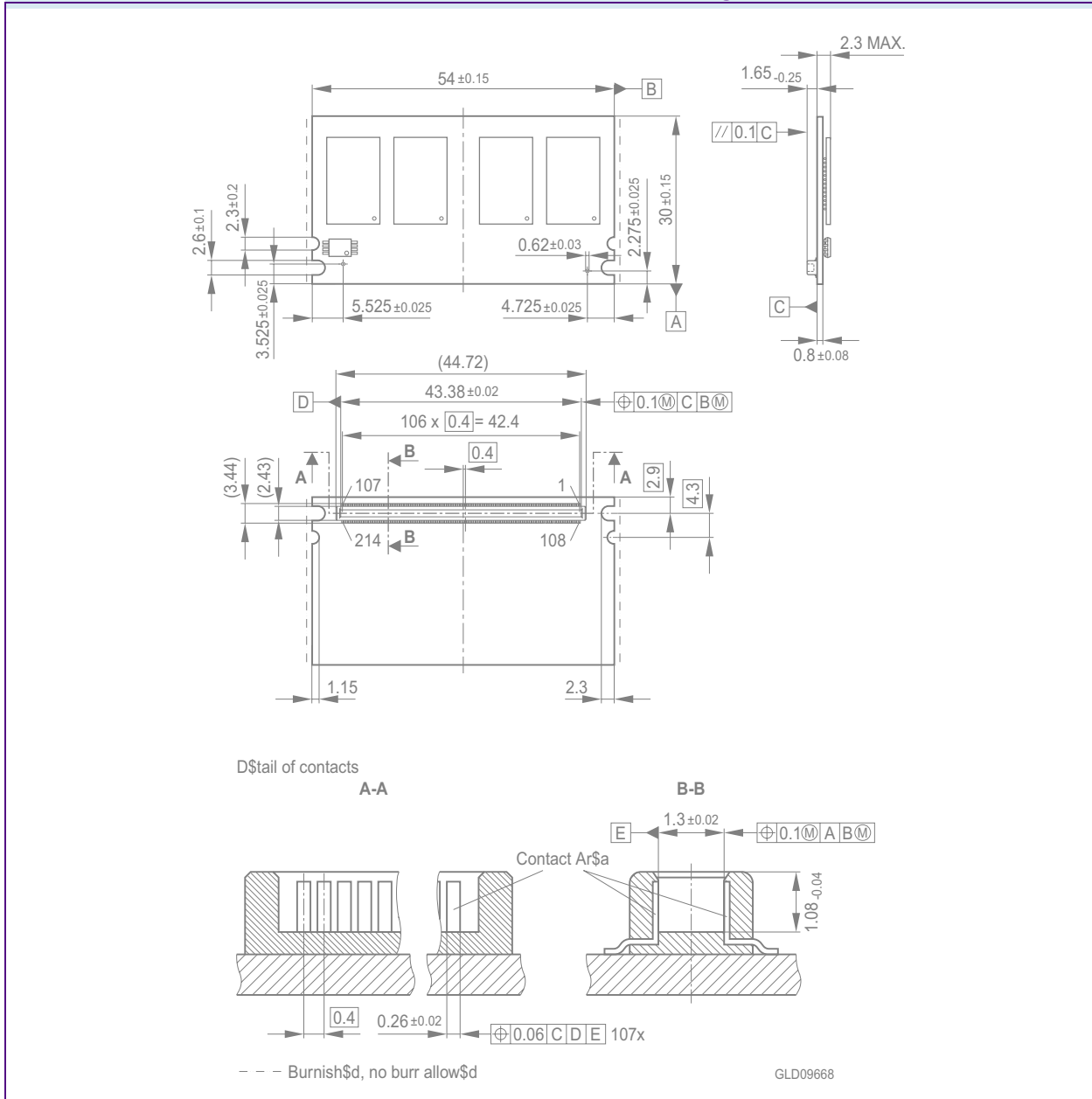

**Notes**

1. Drawing according to ISO 8015
2. Dimensions in mm
3. General tolerances +/- 0.15





## 6 Product Type Nomenclature

Qimonda's nomenclature uses simple coding combined with some proprietary coding. **Table 24** provides examples for module and component product type number as well as the field number. The detailed field description together with possible values and coding explanation is listed for modules in **Table 25** and for components in **Table 26**.

**TABLE 24**  
Nomenclature Fields and Examples

Example for	Field Number										
	1	2	3	4	5	6	7	8	9	10	11
Micro-DIMM	HYS	64	T	64/128	0	2	0	K	M	-5	-A
DDR2 DRAM	HYB	18	T	512/1G	16		0	A	C	-5	

**TABLE 25**  
DDR2 DIMM Nomenclature

Field	Description	Values	Coding
1	Qimonda Module Prefix	HYS	Constant
2	Module Data Width [bit]	64	Non-ECC
		72	ECC
3	DRAM Technology	T	DDR2
4	Memory Density per I/O [Mbit]; Module Density <sup>1)</sup>	32	256 MByte
		64	512 MByte
		128	1 GByte
		256	2 GByte
		512	4 GByte
5	Raw Card Generation	0 .. 9	Look up table
6	Number of Module Ranks	0, 2, 4	1, 2, 4
7	Product Variations	0 .. 9	Look up table
8	Package, Lead-Free Status	A .. Z	Look up table
9	Module Type	D	SO-DIMM
		M	Micro-DIMM
		R	Registered
		U	Unbuffered
		F	Fully Buffered



HYS64T[32/64]0[0/2]0HM-[3S/3.7/5]-A  
Micro-DIMM DDR2 SDRAM Modules

Field	Description	Values	Coding
10	Speed Grade	-2.5F	PC2-6400 5-5-5
		-2.5	PC2-6400 6-6-6
		-3	PC2-5300 4-4-4
		-3S	PC2-5300 5-5-5
		-3.7	PC2-4200 4-4-4
		-5	PC2-3200 3-3-3
11	Die Revision	-A	First
		-B	Second

1) Multiplying "Memory Density per I/O" with "Module Data Width" and dividing by 8 for Non-ECC and 9 for ECC modules gives the overall module memory density in MBytes as listed in column "Coding".

**TABLE 26**  
DDR2 DRAM Nomenclature

Field	Description	Values	Coding
1	Qimonda Component Prefix	HYB	Constant
2	Interface Voltage [V]	18	SSTL_18
3	DRAM Technology	T	DDR2
4	Component Density [Mbit]	256	256 Mbit
		512	512 Mbit
		1G	1 Gbit
		2G	2 Gbit
5+6	Number of I/Os	40	×4
		80	×8
		16	×16
7	Product Variations	0 .. 9	Look up table
8	Die Revision	A	First
		B	Second
9	Package, Lead-Free Status	C	FBGA, lead-containing
		F	FBGA, lead-free
10	Speed Grade	-25F	DDR2-800 5-5-5
		-2.5	DDR2-800 6-6-6
		-3	DDR2-667 4-4-4
		-3S	DDR2-667 5-5-5
		-3.7	DDR2-533 4-4-4
		-5	DDR2-400 3-3-3



# Table of Contents

<b>1</b>	<b>Overview</b> .....	<b>3</b>
1.1	Features .....	3
1.2	Description .....	4
<b>2</b>	<b>Pin Configuration</b> .....	<b>6</b>
2.1	Pin Configuration .....	6
<b>3</b>	<b>Electrical Characteristics</b> .....	<b>13</b>
3.1	Absolute Maximum Ratings .....	13
3.2	DC Operating Conditions .....	14
3.3	Timing Characteristics .....	15
3.3.1	Speed Grade Definitions .....	15
3.3.2	Component AC Timing Parameters .....	16
3.3.3	ODT AC Electrical Characteristics .....	26
3.4	$I_{DD}$ Specifications and Conditions .....	28
<b>4</b>	<b>SPD Codes</b> .....	<b>33</b>
<b>5</b>	<b>Package Outlines</b> .....	<b>39</b>
<b>6</b>	<b>Product Type Nomenclature</b> .....	<b>41</b>
	<b>Table of Contents</b> .....	<b>43</b>

**Edition 2006-11**  
**Published by Qimonda AG**  
**Gustav-Heinemann-Ring 212**  
**D-81739 München, Germany**  
**© Qimonda AG 2006.**  
**All Rights Reserved.**

#### **Legal Disclaimer**

The information given in this Internet Data Sheet shall in no event be regarded as a guarantee of conditions or characteristics ("Beschaffenheitsgarantie"). With respect to any examples or hints given herein, any typical values stated herein and/or any information regarding the application of the device, Qimonda hereby disclaims any and all warranties and liabilities of any kind, including without limitation warranties of non-infringement of intellectual property rights of any third party.

#### **Information**

For further information on technology, delivery terms and conditions and prices please contact your nearest Qimonda Office.

#### **Warnings**

Due to technical requirements components may contain dangerous substances. For information on the types in question please contact your nearest Qimonda Office.

Qimonda Components may only be used in life-support devices or systems with the express written approval of Qimonda, if a failure of such components can reasonably be expected to cause the failure of that life-support device or system, or to affect the safety or effectiveness of that device or system. Life support devices or systems are intended to be implanted in the human body, or to support and/or maintain and sustain and/or protect human life. If they fail, it is reasonable to assume that the health of the user or other persons may be endangered.

[www.qimonda.com](http://www.qimonda.com)