

Description

The GM6251's combine high accuracy with very low power consumption, providing high output current even when the application requires extremely low input-output voltage differential.

The GM6251's include a precision voltage reference, an error correction circuit, over-temperature protection, and a current limited output driver. Fast transient response to load variations provides excellent stability under dynamic load conditions.

The GM6251's come in SOT-25 (150mW), SOT-89 (500mW) and TO-92 packages.

Features

- ◆ Maximum output current 250mA (within maximum power dissipation)
- ◆ Output voltage: from 1.8 V to 6.0V in 0.1V increments
- ◆ Output voltage $\pm 2\%$
- ◆ CMOS low power consumption, typically 1.0 μ A at $V_{OUT} = 5.0V$
- ◆ Input stability typically 0.2%/V
- ◆ Ultra-low dropout voltage 0.38V @ $I_{OUT} = 200mA$ at $V_{OUT} = 5.0V$
- ◆ Small input/ output differential: 0.4V at 160mA ($V_{OUT} = 3.3V$)
- ◆ SOT-25 (150mW), SOT-89 (500mW) and TO-92 packages

Application

Palmtops
Portable Cameras
Video Recorders

Battery Powered Equipment
Reference Voltage Sources

TYPICAL APPLICATION CIRCUITS

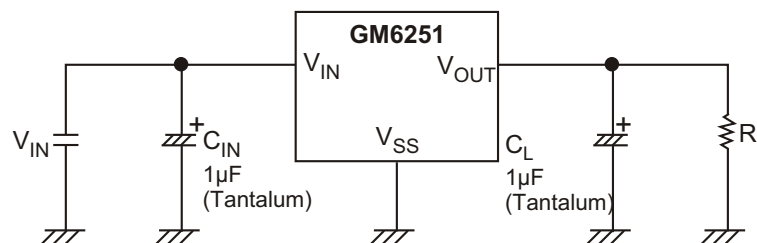

◆ MARKING INFORMATION & PIN CONFIGURATIONS(TOP VIEW)

SOT-25(SOT-23-5)

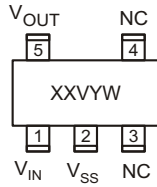

TO-92

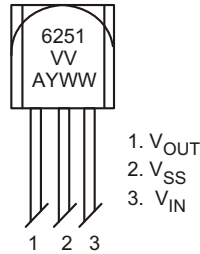

SOT-89

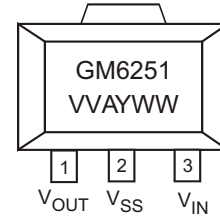

XX = Specific Device Code(FA = GM6251)
 V = Voltage Code
 VV = Voltage Suffix (18=1.8V ,50=5.0V)
 A = Assembly Location
 Y = Year
 WW, W= Work Week

◆ ORDERING INFORMATION

Ordering Number	Output Voltage	Voltage Code	Package	Shipping
GM6251-1.8T92B	1.8V		TO-92	1,000 Units/ ESD Bag
GM6251-1.8T92RL	1.8V		TO-92	2,000 Units/ Ammo Pack (Tape)
GM6251-1.8ST25R	1.8V	E	SOT-25	3,000 Units/ Tape and Reel
GM6251-1.8ST89R	1.8V		SOT-89	1,000 Units/ Tape and Reel
GM6251-2.5T92B	2.5V		TO-92	1,000 Units/ ESD Bag
GM6251-2.5T92RL	2.5V		TO-92	2,000 Units/ Ammo Pack (Tape)
GM6251-2.5ST25R	2.5V	G	SOT-25	3,000 Units/ Tape and Reel
GM6251-2.5ST89R	2.5V		SOT-89	1,000 Units/ Tape and Reel
GM6251-2.7T92B	2.7V		TO-92	1,000 Units/ ESD Bag
GM6251-2.7T92RL	2.7V		TO-92	2,000 Units/ Ammo Pack (Tape)
GM6251-2.7ST25R	2.7V	T	SOT-25	3,000 Units/ Tape and Reel
GM6251-2.7ST89R	2.7V		SOT-89	1,000 Units/ Tape and Reel
GM6251-2.8T92B	2.8V		TO-92	1,000 Units/ ESD Bag
GM6251-2.8T92RL	2.8V		TO-92	2,000 Units/ Ammo Pack (Tape)
GM6251-2.8ST25R	2.8V	H	SOT-25	3,000 Units/ Tape and Reel
GM6251-2.8ST89R	2.8V		SOT-89	1,000 Units/ Tape and Reel
GM6251-3.0T92B	3.0V		TO-92	1,000 Units/ ESD Bag
GM6251-3.0T92RL	3.0V		TO-92	2,000 Units/ Ammo Pack (Tape)
GM6251-3.0ST25R	3.0V	J	SOT-25	3,000 Units/ Tape and Reel
GM6251-3.0ST89R	3.0V		SOT-89	1,000 Units/ Tape and Reel

GM6251

* For detail Ordering Number identification, please see last page.

◆ ORDERING INFORMATION (Continued)

Ordering Number	Output Voltage	Voltage Code	Package	Shipping
GM6251-3.2T92B	3.2V		TO-92	1,000 Units/ ESD Bag
GM6251-3.2T92RL	3.2V		TO-92	2,000 Units/ Ammo Pack (Tape)
GM6251-3.2ST25R	3.2V	U	SOT-25	3,000 Units/ Tape and Reel
GM6251-3.2ST89R	3.2V		SOT-89	1,000 Units/ Tape and Reel
GM6251-3.3T92B	3.3V		TO-92	1,000 Units/ ESD Bag
GM6251-3.3T92RL	3.3V		TO-92	2,000 Units/ Ammo Pack (Tape)
GM6251-3.3ST25R	3.3V	K	SOT-25	3,000 Units/ Tape and Reel
GM6251-3.3ST89R	3.3V		SOT-89	1,000 Units/ Tape and Reel
GM6251-3.5T92B	3.5V		TO-92	1,000 Units/ ESD Bag
GM6251-3.5T92RL	3.5V		TO-92	2,000 Units/ Ammo Pack (Tape)
GM6251-3.5ST25R	3.5V	V	SOT-25	3,000 Units/ Tape and Reel
GM6251-3.5ST89R	3.5V		SOT-89	1,000 Units/ Tape and Reel
GM6251-3.6T92B	3.6V		TO-92	1,000 Units/ ESD Bag
GM6251-3.6T92RL	3.6V		TO-92	2,000 Units/ Ammo Pack (Tape)
GM6251-3.6ST25R	3.6V	L	SOT-25	3,000 Units/ Tape and Reel
GM6251-3.6ST89R	3.6V		SOT-89	1,000 Units/ Tape and Reel
GM6251-4.0T92B	4.0V		TO-92	1,000 Units/ ESD Bag
GM6251-4.0T92RL	4.0V		TO-92	2,000 Units/ Ammo Pack (Tape)
GM6251-4.0ST25R	4.0V	M	SOT-25	3,000 Units/ Tape and Reel
GM6251-4.0ST89R	4.0V		SOT-89	1,000 Units/ Tape and Reel
GM6251-4.4T92B	4.4V		TO-92	1,000 Units/ ESD Bag
GM6251-4.4T92RL	4.4V		TO-92	2,000 Units/ Ammo Pack (Tape)
GM6251-4.4ST25R	4.4V	W	SOT-25	3,000 Units/ Tape and Reel
GM6251-4.4ST89R	4.4V		SOT-89	1,000 Units/ Tape and Reel
GM6251-4.5T92B	4.5V		TO-92	1,000 Units/ ESD Bag
GM6251-4.5T92RL	4.5V		TO-92	2,000 Units/ Ammo Pack (Tape)
GM6251-4.5ST25R	4.5V	N	SOT-25	3,000 Units/ Tape and Reel
GM6251-4.5ST89R	4.5V		SOT-89	1,000 Units/ Tape and Reel
GM6251-5.0T92B	5.0V		TO-92	1,000 Units/ ESD Bag
GM6251-5.0T92RL	5.0V		TO-92	2,000 Units/ Ammo Pack (Tape)
GM6251-5.0ST25R	5.0V	Q	SOT-25	3,000 Units/ Tape and Reel
GM6251-5.0ST89R	5.0V		SOT-89	1,000 Units/ Tape and Reel

* For detail Ordering Number identification, please see last page.

◆ ABSOLUTE MAXIMUM RATINGS

PARAMETER	SYMBOL	RATINGS	UNITS
Input Voltage	V_{IN}	12	V
Output Voltage	V_{OUT}	$V_{SS} - 0.3 \sim V_{IN} + 0.3$	V
Output Current	I_{OUT}	500	mA
Continuous Total Power Dissipation (SOT - 89)	P_D	500	mW
Operating Ambient Temperature	T_{opr}	-30 ~ +80	°C
Storage Temperature	T_{stg}	-40 ~ +125	°C

◆ BLOCK DIAGRAM

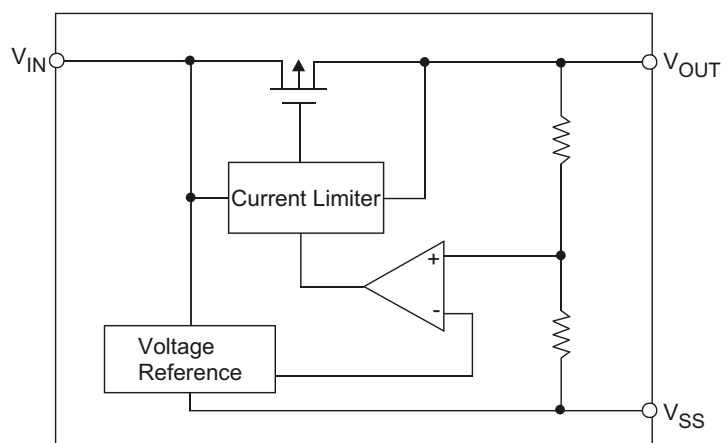

◆ **ELECTRICAL CHARACTERISTICS** ($T_A = 25^\circ\text{C}$ unless otherwise noted)

Parameter	Symbol	Condition	Min	Typ	Max	Unit	Circuit	
Output Voltage	GM6251-1.8V	$V_{\text{OUT(E)}}^{(\text{Note 2})}$	$I_{\text{OUT}}=40\text{mA},$ $V_{\text{IN}} > V_{\text{Drop}} + V_{\text{OUT}}$	1.764	1.800	1.836	V	1
	GM6251-2.5V			2.450	2.500	2.550		
	GM6251-2.7V			2.646	2.700	2.754		
	GM6251-2.8V			2.744	2.800	2.856		
	GM6251-3.0V			2.940	3.000	3.060		
	GM6251-3.2V			3.136	3.200	3.264		
	GM6251-3.3V			3.234	3.300	3.366		
	GM6251-3.5V			3.430	3.500	3.570		
	GM6251-3.6V			3.528	3.600	3.672		
	GM6251-4.0V			3.920	4.000	4.080		
	GM6251-4.4V			4.312	4.400	4.488		
	GM6251-4.5V			4.410	4.500	4.590		
	GM6251-5.0V			4.900	5.000	5.100		
Maximum Output Current	GM6251-1.8V	$I_{\text{OUT max}}$	250			mA	1	
	GM6251-2.5V							$V_{\text{IN}}=3.0\text{V}, V_{\text{OUT(E)}} \geq 1.62\text{V}$
	GM6251-2.7V							$V_{\text{IN}}=4.0\text{V}, V_{\text{OUT(E)}} \geq 2.3\text{V}$
	GM6251-2.8V							$V_{\text{IN}}=4.0\text{V}, V_{\text{OUT(E)}} \geq 2.43\text{V}$
	GM6251-3.0V							$V_{\text{IN}}=4.0\text{V}, V_{\text{OUT(E)}} \geq 2.52\text{V}$
	GM6251-3.2V							$V_{\text{IN}}=4.0\text{V}, V_{\text{OUT(E)}} \geq 2.7\text{V}$
	GM6251-3.3V							$V_{\text{IN}}=4.0\text{V}, V_{\text{OUT(E)}} \geq 2.88\text{V}$
	GM6251-3.5V							$V_{\text{IN}}=4.0\text{V}, V_{\text{OUT(E)}} \geq 2.97\text{V}$
	GM6251-3.6V							$V_{\text{IN}}=5.0\text{V}, V_{\text{OUT(E)}} \geq 3.15\text{V}$
	GM6251-4.0V							$V_{\text{IN}}=5.0\text{V}, V_{\text{OUT(E)}} \geq 3.24\text{V}$
	GM6251-4.4V							$V_{\text{IN}}=5.0\text{V}, V_{\text{OUT(E)}} \geq 3.6\text{V}$
	GM6251-4.5V							$V_{\text{IN}}=6.0\text{V}, V_{\text{OUT(E)}} \geq 3.96\text{V}$
	GM6251-5.0V							$V_{\text{IN}}=6.0\text{V}, V_{\text{OUT(E)}} \geq 4.05\text{V}$
		$V_{\text{IN}}=6.0\text{V}, V_{\text{OUT(E)}} \geq 4.5\text{V}$						

◆ ELECTRICAL CHARACTERISTICS ($T_A = 25^\circ\text{C}$ unless otherwise noted)

Parameter		Symbol	Condition	Min	Typ	Max	Unit	Circuit
Load Stability	GM6251-1.8V	V_{OUT}	$V_{IN}=2.8\text{V}, 1\text{mA} \leq I_{OUT} \leq 60\text{mA}$		45	90	mV	1
	GM6251-2.5V		$V_{IN}=3.5\text{V}, 1\text{mA} \leq I_{OUT} \leq 80\text{mA}$		45	90		
	GM6251-2.7V		$V_{IN}=3.7\text{V}, 1\text{mA} \leq I_{OUT} \leq 80\text{mA}$		45	90		
	GM6251-2.8V		$V_{IN}=3.8\text{V}, 1\text{mA} \leq I_{OUT} \leq 80\text{mA}$		45	90		
	GM6251-3.0V		$V_{IN}=4.0\text{V}, 1\text{mA} \leq I_{OUT} \leq 80\text{mA}$		45	90		
	GM6251-3.2V		$V_{IN}=4.2\text{V}, 1\text{mA} \leq I_{OUT} \leq 80\text{mA}$		45	90		
	GM6251-3.3V		$V_{IN}=4.3\text{V}, 1\text{mA} \leq I_{OUT} \leq 100\text{mA}$		45	90		
	GM6251-3.5V		$V_{IN}=4.5\text{V}, 1\text{mA} \leq I_{OUT} \leq 100\text{mA}$		45	90		
	GM6251-3.6V		$V_{IN}=4.6\text{V}, 1\text{mA} \leq I_{OUT} \leq 100\text{mA}$		45	90		
	GM6251-4.0V		$V_{IN}=5.0\text{V}, 1\text{mA} \leq I_{OUT} \leq 100\text{mA}$		40	80		
	GM6251-4.4V		$V_{IN}=5.4\text{V}, 1\text{mA} \leq I_{OUT} \leq 100\text{mA}$		40	80		
	GM6251-4.5V		$V_{IN}=5.5\text{V}, 1\text{mA} \leq I_{OUT} \leq 100\text{mA}$		40	80		
	GM6251-5.0V		$V_{IN}=6.0\text{V}, 1\text{mA} \leq I_{OUT} \leq 100\text{mA}$		40	80		
Input - Output Voltage Differential <small>(Note 3)</small>	GM6251-1.8V	Vdif1	$I_{OUT} = 60\text{mA}$		180	360	mV	1
		Vdif2	$I_{OUT} = 160\text{mA}$		900	1300		
	GM6251-2.5V	Vdif1	$I_{OUT} = 80\text{mA}$		180	360		
		Vdif2	$I_{OUT} = 160\text{mA}$		550	850		
	GM6251-2.7V	Vdif1	$I_{OUT} = 80\text{mA}$		180	360		
		Vdif2	$I_{OUT} = 160\text{mA}$		400	700		
	GM6251-2.8V	Vdif1	$I_{OUT} = 80\text{mA}$		180	360		
		Vdif2	$I_{OUT} = 160\text{mA}$		400	700		
	GM6251-3.0V	Vdif1	$I_{OUT} = 80\text{mA}$		180	360		
		Vdif2	$I_{OUT} = 160\text{mA}$		400	700		
	GM6251-3.2V	Vdif1	$I_{OUT} = 80\text{mA}$		180	360		
		Vdif2	$I_{OUT} = 160\text{mA}$		400	700		
	GM6251-3.3V	Vdif1	$I_{OUT} = 100\text{mA}$		170	330		
		Vdif2	$I_{OUT} = 200\text{mA}$		400	630		
	GM6251-3.5V	Vdif1	$I_{OUT} = 100\text{mA}$		120	300		
		Vdif2	$I_{OUT} = 200\text{mA}$		380	600		
	GM6251-3.6V	Vdif1	$I_{OUT} = 100\text{mA}$		120	300		
		Vdif2	$I_{OUT} = 200\text{mA}$		380	600		
	GM6251-4.0V	Vdif1	$I_{OUT} = 100\text{mA}$		170	330		
		Vdif2	$I_{OUT} = 200\text{mA}$		400	630		
	GM6251-4.4V	Vdif1	$I_{OUT} = 100\text{mA}$		120	300		
		Vdif2	$I_{OUT} = 200\text{mA}$		380	600		
	GM6251-4.5V	Vdif1	$I_{OUT} = 100\text{mA}$		120	300		
		Vdif2	$I_{OUT} = 200\text{mA}$		380	600		
GM6251-5.0V	Vdif1	$I_{OUT} = 100\text{mA}$		120	300			
	Vdif2	$I_{OUT} = 200\text{mA}$		380	600			

◆ **ELECTRICAL CHARACTERISTICS** ($T_A = 25^\circ\text{C}$ unless otherwise noted)

Parameter		Symbol	Condition	Min	Typ	Max	Unit	Circuit
Supply Current	GM6251-1.8V	I_{SS}	$V_{IN} = 2.8V$					
	GM6251-2.5V		$V_{IN} = 3.5V$					
	GM6251-2.7V		$V_{IN} = 3.7V$					
	GM6251-2.8V		$V_{IN} = 3.8V$					
	GM6251-3.0V		$V_{IN} = 4.0V$					
	GM6251-3.2V		$V_{IN} = 4.2V$					
	GM6251-3.3V		$V_{IN} = 4.3V$		1.0	2.9	μA	2
	GM6251-3.5V		$V_{IN} = 4.5V$					
	GM6251-3.6V		$V_{IN} = 4.6V$					
	GM6251-4.0V		$V_{IN} = 5.0V$					
	GM6251-4.4V		$V_{IN} = 5.4V$					
	GM6251-4.5V		$V_{IN} = 5.5V$					
	GM6251-5.0V		$V_{IN} = 6.0V$					
	Output Current Limit					500		mA
Input Stability	GM6251-1.8V	$\frac{V_{OUT}}{V_{IN} \cdot V_{OUT}}$	$I_{OUT} = 40\text{mA}$ $2.8V \leq V_{IN} \leq 10.0V$					
	GM6251-2.5V		$I_{OUT} = 40\text{mA}$ $3.5V \leq V_{IN} \leq 10.0V$					
	GM6251-2.7V		$I_{OUT} = 40\text{mA}$ $3.7V \leq V_{IN} \leq 10.0V$					
	GM6251-2.8V		$I_{OUT} = 40\text{mA}$ $3.8V \leq V_{IN} \leq 10.0V$					
	GM6251-3.0V		$I_{OUT} = 40\text{mA}$ $4.0V \leq V_{IN} \leq 10.0V$					
	GM6251-3.2V		$I_{OUT} = 40\text{mA}$ $4.2V \leq V_{IN} \leq 10.0V$					
	GM6251-3.3V		$I_{OUT} = 40\text{mA}$ $4.3V \leq V_{IN} \leq 10.0V$		0.2	0.3	%/V	1
	GM6251-3.5V		$I_{OUT} = 40\text{mA}$ $4.5V \leq V_{IN} \leq 10.0V$					
	GM6251-3.6V		$I_{OUT} = 40\text{mA}$ $4.6V \leq V_{IN} \leq 10.0V$					
	GM6251-4.0V		$I_{OUT} = 40\text{mA}$ $5.0V \leq V_{IN} \leq 10.0V$					
	GM6251-4.4V		$I_{OUT} = 40\text{mA}$ $5.4V \leq V_{IN} \leq 10.0V$					
	GM6251-4.5V		$I_{OUT} = 40\text{mA}$ $5.5V \leq V_{IN} \leq 10.0V$					
	GM6251-5.0V		$I_{OUT} = 40\text{mA}$ $6.0V \leq V_{IN} \leq 10.0V$					
	Input Voltage		V_{IN}				10	V
Output Voltage Temperature Characteristics		$\frac{V_{OUT}}{T_{opr} \cdot V_{OUT}}$	$I_{OUT} = 10\text{mA}$ $-30^\circ\text{C} \leq T_{opr} \leq 80^\circ\text{C}$		± 100		ppm/ $^\circ\text{C}$	1

Note: 1. $V_{OUT}(T)$ = Specified Output Voltage

2. $V_{OUT}(E)$ = Effective Output Voltage (the output voltage when " $V_{OUT}(T) + 1.0V$ " is provided at the V_{IN} pin while maintaining a certain I_{OUT} value)

3. $V_{dif} = \{V_{IN1} \text{ (Note 4)} - V_{OUT}(E)\}$

4. V_{IN1} = The input voltage at the time 98% of $V_{OUT}(E)$ is output (input voltage has been gradually reduced).

* Output Voltage from 1.8V to 6.0V in 0.1V increments are available

◆ DIRECTIONS FOR USE

Notes on Use

1. Please use this IC within the stipulated absolute maximum ratings as the IC is liable to malfunction outside of such parameters.
2. There is a possibility that oscillation may occur as a result of the impedance present between the power supply and the IC's input. Where impedance is 10W or more, please use a capacitor (C_{IN}) of at least $1\mu\text{F}$.
With a large output current, operations can be stabilised by increasing capacitor size (C_{IN}). If C_{IN} is small and capacitor size (C_L) is increased, there is a possibility of oscillation due to input impedance. In such cases, operations can be stabilised by either increasing the size of C_{IN} or decreasing the size of C_L .
3. Please ensure that output current (I_{OUT}) is less than $Pd \div (V_{IN} - V_{OUT})$ and does not exceed the stipulated continuous total power dissipation value (Pd) for the package.

◆ TEST CIRCUIT

Circuit 1

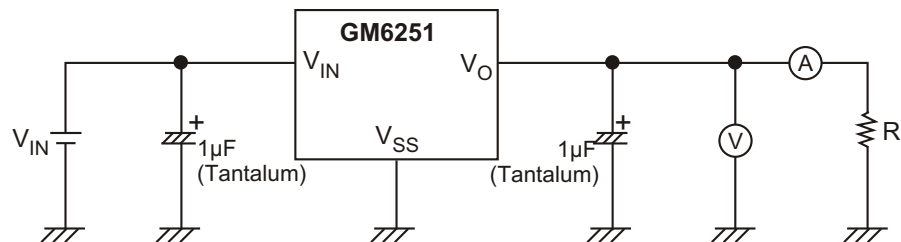

Circuit 2

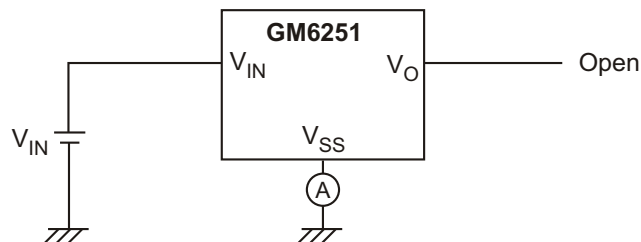

◆ PERFORMANCE CHARACTERISTICS FOR GM6251 - 3.0

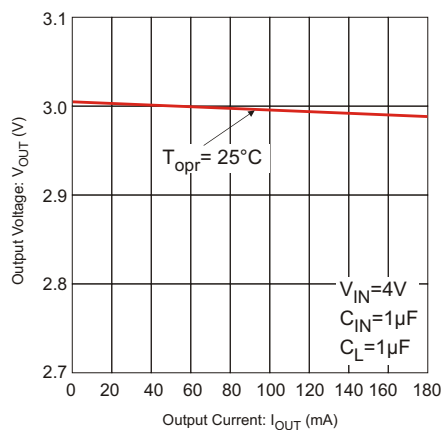

Figure 1: Output Voltage vs. Output Current

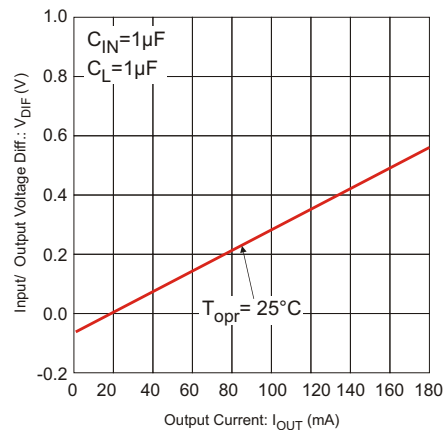

Figure 2: Input/ Output Voltage differential vs. Output Current

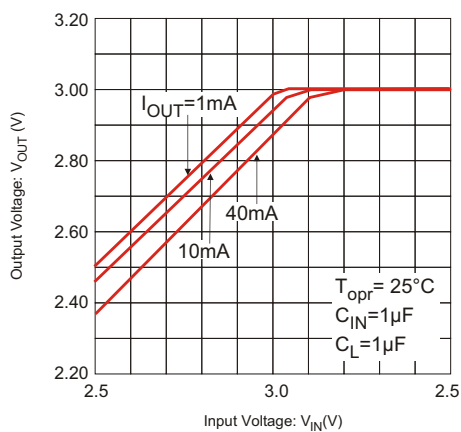

Figure 3: Output Voltage vs. Input voltage

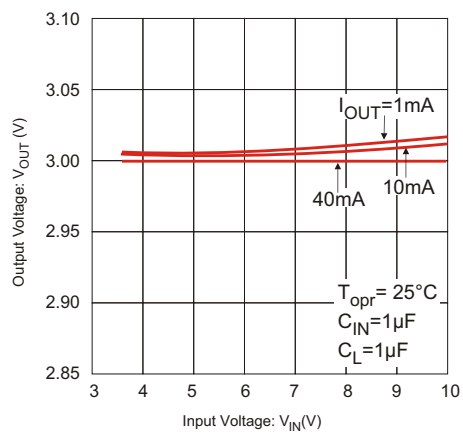

Figure 4: Output Voltage vs. Input voltage

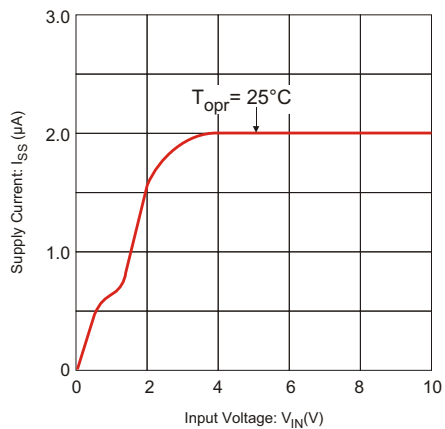

Figure 5: Supply Current vs. Input Voltage

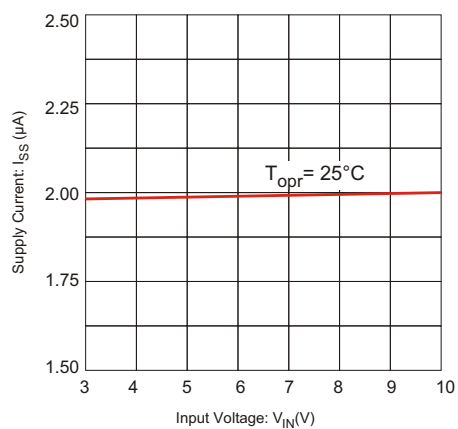

Figure 6: Supply Current vs. Input Voltage

◆ PERFORMANCE CHARACTERISTICS FOR GM6251- 3.0

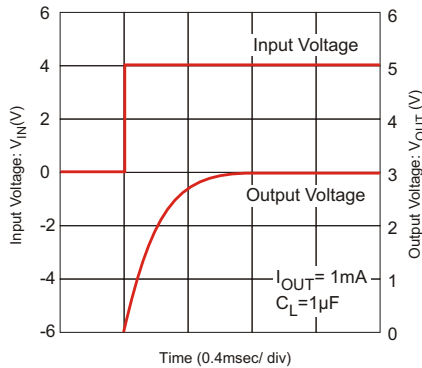

Figure 7: Input Transient Response 1

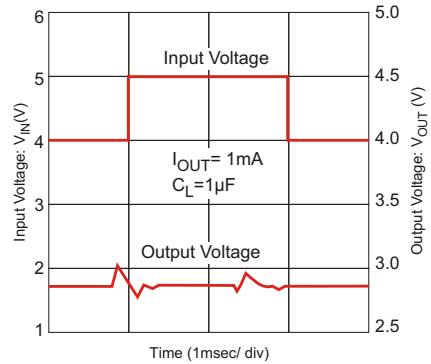

Figure 8: Input Transient Response 2

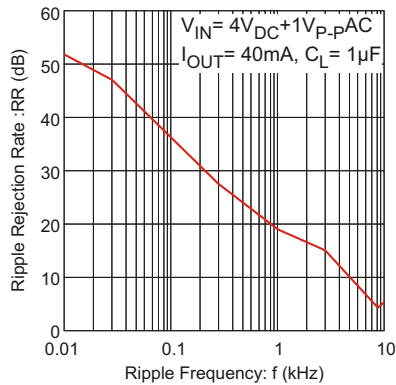
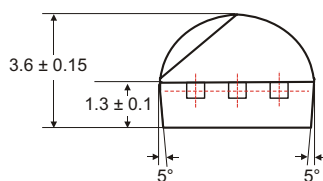
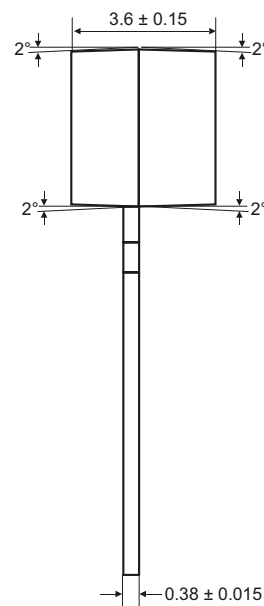
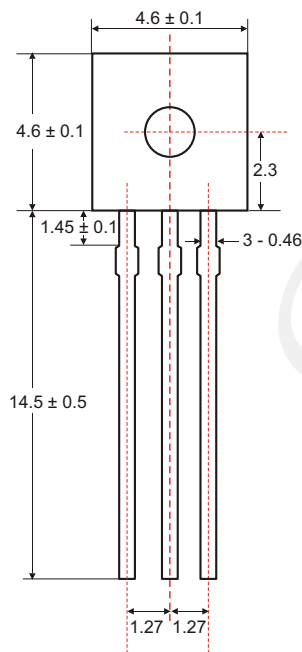

Figure 9: Ripple Rejection Rate

◆ TO-92 PACKAGE OUTLINE DIMENSIONS



Unit: mm

◆ SOT-25(SOT-23-5) PACKAGE OUTLINE DIMENSIONS

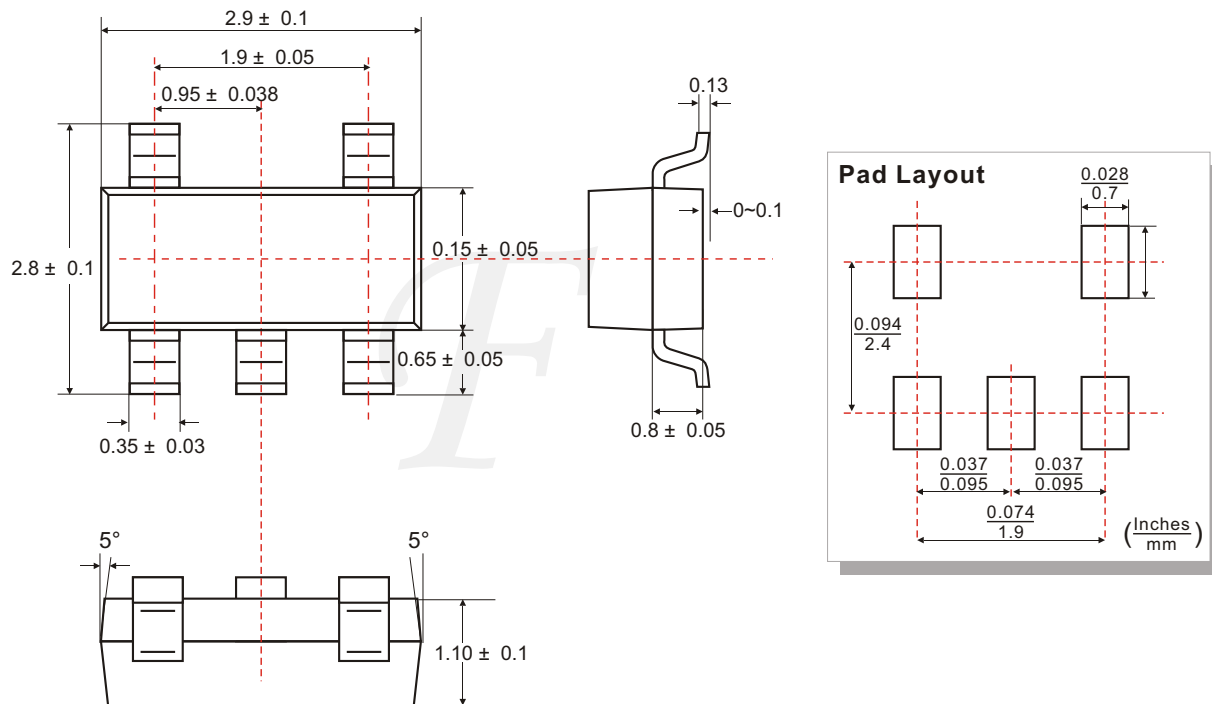

◆ SOT-89 PACKAGE OUTLINE DIMENSIONS

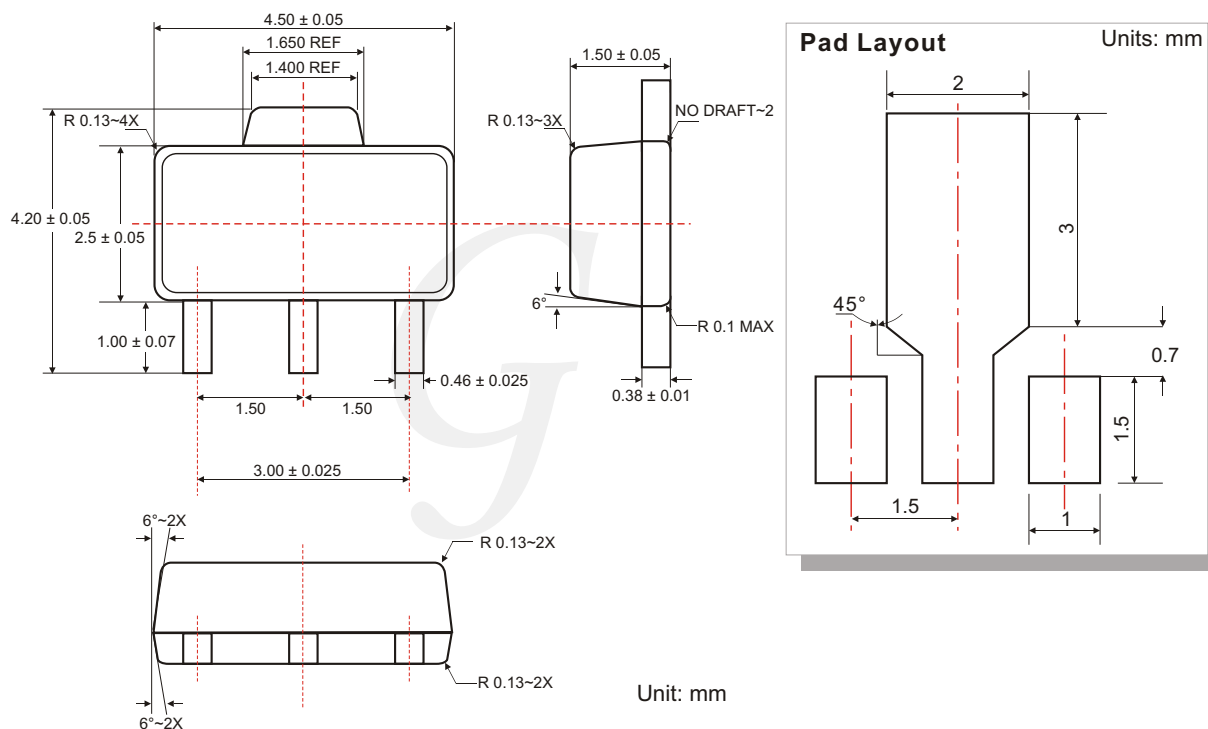

◆ ORDERING NUMBER

