

# 128Kx32 CMOS High Speed Static RAM

## FEATURES

- 128Kx32 bit CMOS Static
- Analog SHARC™ External Memory Solution
  - ADSP-21060L
  - ADSP-21062L
- Random Access Memory Array
  - Fast Access Times: 12, 15 and 20ns
  - User Configurable Organization
  - with Minimal Additional Logic
  - Master Output Enable and Write Control
  - TTL Compatible Inputs and Outputs
  - Fully Static, No Clocks
- Surface Mount Package
  - 68 Lead PLCC, No. 99 (JEDEC MO-47AE)
  - Small Footprint, 0.990 Sq. In.
  - Multiple Ground Pins for Maximum
  - Noise Immunity
- Single 3.3V (±5%) Supply Operation

## DESCRIPTION

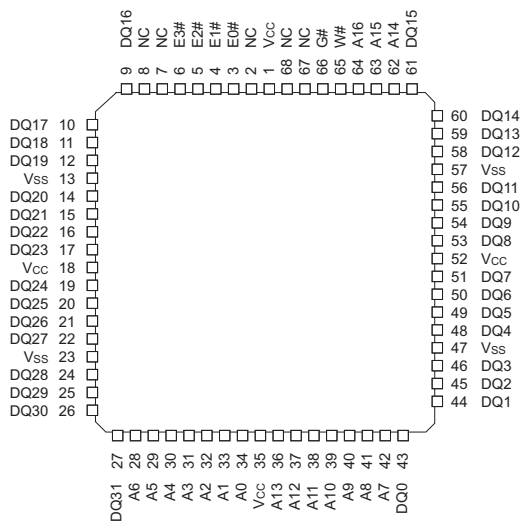
The EDI8L32128V is a high speed, 3.3V, four megabit density Static RAM. The device is available with access times of 12, 15 and 20ns, allowing the device to support 60MHz DSPs with no wait states. The high speed, 3.3V supply voltage and byte configurability make the device ideal for interfacing with Analog Devices ADSP-21062L or ADSP-21060L SHARC DSPs.

The device can be configured as a 128Kx32 and used to create a single chip external data memory solution for the SHARC (figure 1). Providing a 51% space savings when compared to four 128Kx8, 400mil wide plastic SOJs. The EDI8L32128V has a 10pf load on the data lines vs. 24pf for four plastic SOJs. Memory upgrades in the same footprint can be accomplished with the EDI8L32256V (256Kx32) or the EDI8L32512V (512Kx32). This is covered in detail in the application report "The EDI's x32 MCM-L SRAM Family: Integrated Memory Solution for the Analog SHARC DSP"

Alternatively the device's chip enables can configure it as a 256Kx16. A 256Kx48 program memory array for the SHARC is created using three devices (figure 2). If this memory is too deep, two 128Kx24's (EDI8L24128V) can be used to create a 128Kx48 memory array.

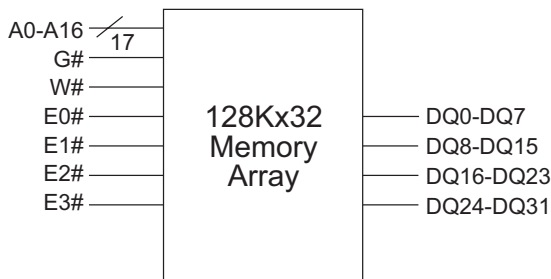
Note: Solder Reflow temperature should not exceed 260°C for 10 seconds

## PIN CONFIGURATIONS AND BLOCK DIAGRAM

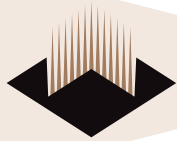


## PIN NAMES

A0-A16	Address Inputs
E0#-E3#	Chip Enables (One per Byte)
W#	Master Write Enable
G#	Master Output Enable
DQ0-DQ31	Common Data Input/Output
Vcc	Power (+3.3V±10%)
Vss	Ground
NC	No Connection



Note: Pin 2 & 67 on the 64Kx32 (EDI8L3265C) and the 256Kx32 (EDI8L32256C) are word select pins.



**ABSOLUTE MAXIMUM RATINGS\***

Voltage on any pin relative to V <sub>SS</sub>	-0.5V to 4.6V
Operating Temperature T <sub>A</sub> (Ambient)	0°C to +70°C
Commercial	0°C to +70°C
Industrial	-40°C to +85°C
Storage Temperature	-55°C to +125°C
Power Dissipation	3 Watts
Output Current	20 mA
Junction Temperature, T <sub>J</sub>	175°C

\*Stress greater than those listed under "Absolute Maximum Ratings" may cause permanent damage to the device. This is a stress rating only and functional operation of the device at these or any other conditions greater than those indicated in the operational sections of this specification is not implied. Exposure to absolute maximum rating conditions for extended periods may affect reliability.

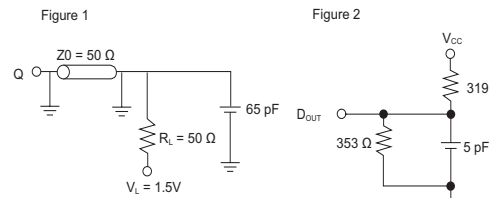
**RECOMMENDED DC OPERATING CONDITIONS**

Parameter	Sym	Min	Typ	Max	Units
Supply Voltage	V <sub>CC</sub>	3.135V	3.3	3.465V	V
Supply Voltage	V <sub>SS</sub>	0	0	0	V
Input High Voltage	V <sub>IH</sub>	2.2	—	V <sub>CC</sub> +0.3	V
Input Low Voltage	V <sub>IL</sub>	-0.3	—	0.8	V

**AC TEST CONDITIONS**

Input Pulse Levels	V <sub>SS</sub> to 3.0V
Input Rise and Fall Times	5ns
Input and Output Timing Levels	1.5V
Output Load	Figure 1

(note: For t<sub>EHQZ</sub>, t<sub>GHQZ</sub> and t<sub>WLQZ</sub>, C<sub>L</sub> = 5pF) (see figure 2)



**DC ELECTRICAL CHARACTERISTICS**

Parameter	Sym	Conditions	Min	Max			Units ns
				12	15	20	
Operating Power Supply Current	I <sub>CC1</sub>	W# = V <sub>IL</sub> , I <sub>I/O</sub> = 0mA, Min Cycle		680	660	620	mA
Standby (TTL) Supply Current	I <sub>CC2</sub>	E# V <sub>IH</sub> , V <sub>IN</sub> = V <sub>IL</sub> or V <sub>IN</sub> = V <sub>IH</sub> , f=0MHz		120	120	120	mA
Full Standby CMOS Supply Current	I <sub>CC3</sub>	E# V <sub>CC</sub> -0.2V V <sub>IN</sub> = V <sub>CC</sub> -0.2V or V <sub>IN</sub> = 0.2V		40	40	40	mA
Input Leakage Current	I <sub>LI</sub>	V <sub>IN</sub> = 0V to V <sub>CC</sub>			±10		µA
Output Leakage Current	I <sub>LO</sub>	V I/O = 0V to V <sub>CC</sub>			±10		µA
Output High Voltage	V <sub>OH</sub>	I <sub>OH</sub> = -4.0mA	2.4				V
Output Low Voltage	V <sub>OL</sub>	I <sub>OL</sub> = 8.0mA			0.4		V

Typical: T<sub>A</sub>=25°C, V<sub>CC</sub>=3.3V

**TRUTH TABLE**

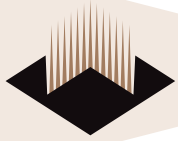
G#	E#	W#	Mode	Output	Power
X	H	X	Standby	High Z	I <sub>CC2</sub> , I <sub>CC3</sub>
H	L	H	Output Deselect	High Z	I <sub>CC1</sub>
L	L	H	Read	D <sub>OUT</sub>	I <sub>CC1</sub>
X	L	L	Write	D <sub>IN</sub>	I <sub>CC1</sub>

**CAPACITANCE**

(f=1.0MHz, V<sub>IN</sub>=V<sub>CC</sub> or V<sub>SS</sub>)

Parameter	Sym	Max	Unit
Address Lines	CA	40	pF
Data Lines	CD/Q	10	pF
Write & Output Enable Lines	W#, G#	40	pF
Chip Enable Lines	E0# - E3#	8	pF

These parameters are sampled, not 100% tested.

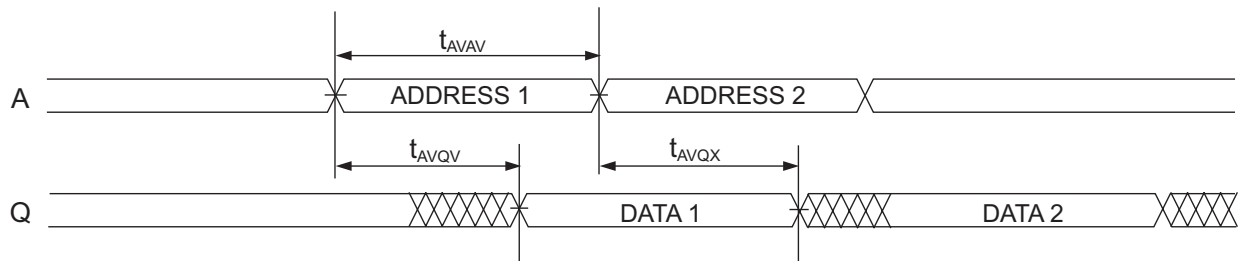


**AC CHARACTERISTICS READ CYCLE**

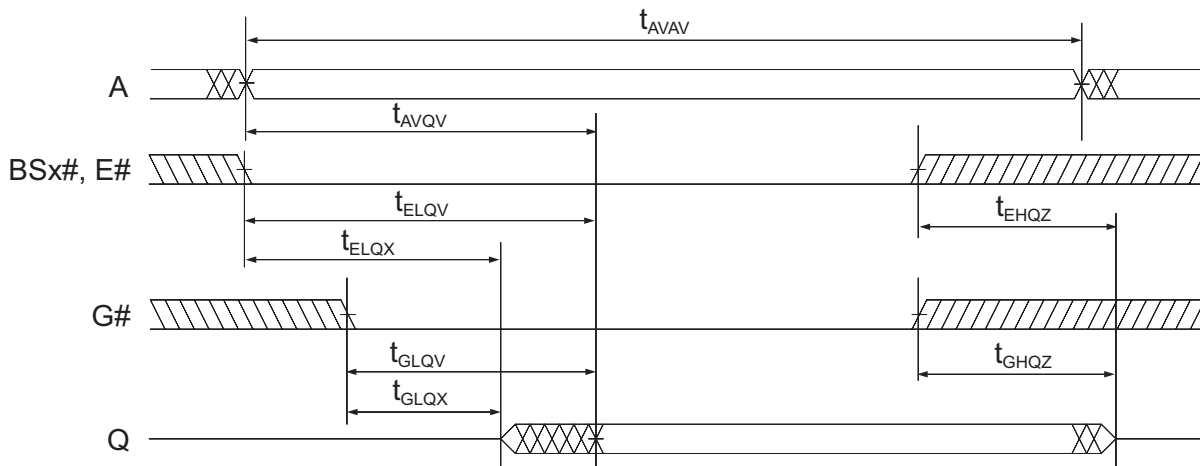
Parameter	Symbol		12ns		15ns		20ns		Units
	JEDEC	Alt.	Min	Max	Min	Max	Min	Max	
Read Cycle Time	t <sub>AVAV</sub>	t <sub>RC</sub>	12		15		20		ns
Address Access Time	t <sub>AVQV</sub>	t <sub>AA</sub>		12		15		20	ns
Chip Enable Access Time	t <sub>ELQV</sub>	t <sub>ACS</sub>		8		10		20	ns
Chip Enable to Output in Low Z (1)	t <sub>ELQX</sub>	t <sub>CLZ</sub>	2		3		3		ns
Chip Disable to Output in High Z (1)	t <sub>EHQZ</sub>	t <sub>CHZ</sub>		7		8		10	ns
Output Hold from Address Change	t <sub>AVQX</sub>	t <sub>OH</sub>	3		3		3		ns
Output Enable to Output Valid	t <sub>GLQV</sub>	t <sub>OE</sub>		5		6		8	ns
Output Enable to Output in Low Z (1)	t <sub>GLQX</sub>	t <sub>OLZ</sub>	2		2		2		ns
Output Disable to Output in High Z(1)	t <sub>GHQZ</sub>	t <sub>OHZ</sub>		4		5		8	ns

Note 1: Parameter guaranteed, but not tested.

**READ CYCLE 1 - W# HIGH, G#, E# LOW**



**READ CYCLE 2 - W# HIGH**



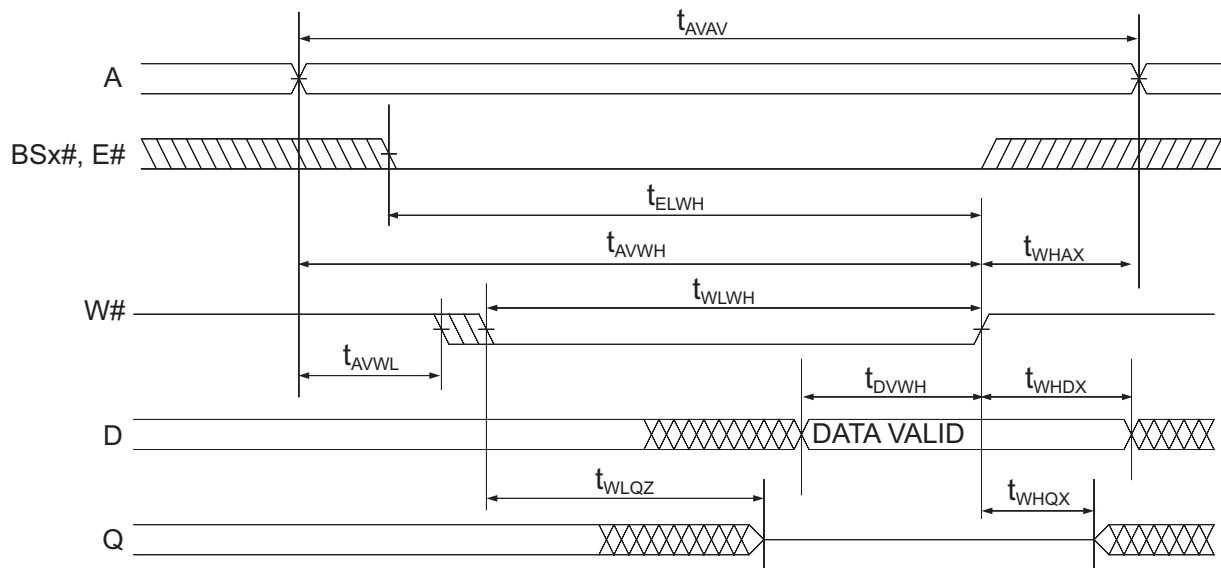


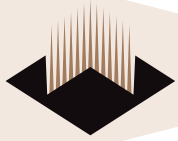
**AC CHARACTERISTICS WRITE CYCLE**

Parameter	Symbol		12ns		15ns		20ns		Units
	JEDEC	Alt.	Min	Max	Min	Max	Min	Max	
Write Cycle Time	t <sub>AVAV</sub>	t <sub>wc</sub>	12		15		20		ns
Chip Enable to End of Write	t <sub>ELWH</sub>	t <sub>cw</sub>	8		9		15		ns
	t <sub>LEH</sub>	t <sub>cw</sub>	8		9		15		ns
Address Setup Time	t <sub>AVWL</sub>	t <sub>as</sub>	0		0		0		ns
	t <sub>AVEL</sub>	t <sub>as</sub>	0		0		0		ns
Address Valid to End of Write	t <sub>AVWH</sub>	t <sub>aw</sub>	9		10		15		ns
	t <sub>AVEH</sub>	t <sub>aw</sub>	9		10		15		ns
Write Pulse Width	t <sub>WLWH</sub>	t <sub>wp</sub>	9		10		15		ns
	t <sub>WLEH</sub>	t <sub>wp</sub>	9		10		15		ns
Write Recovery Time	t <sub>WHAX</sub>	t <sub>wr</sub>	0		0		0		ns
	t <sub>EHAX</sub>	t <sub>wr</sub>	0		0		0		ns
Data Hold Time	t <sub>WHDX</sub>	t <sub>dh</sub>	0		0		0		ns
	t <sub>EHDX</sub>	t <sub>dh</sub>	0		0		0		ns
Write to Output in High Z (1)	t <sub>WLQZ</sub>	t <sub>whz</sub>	0	5	0	6	0	7	ns
Data to Write Time	t <sub>DVWH</sub>	t <sub>dw</sub>	5		6		8		ns
	t <sub>DVEH</sub>	t <sub>dw</sub>	5		6		8		ns
Output Active from End of Write (1)	t <sub>WHQX</sub>	t <sub>wlz</sub>	2		2		2		ns

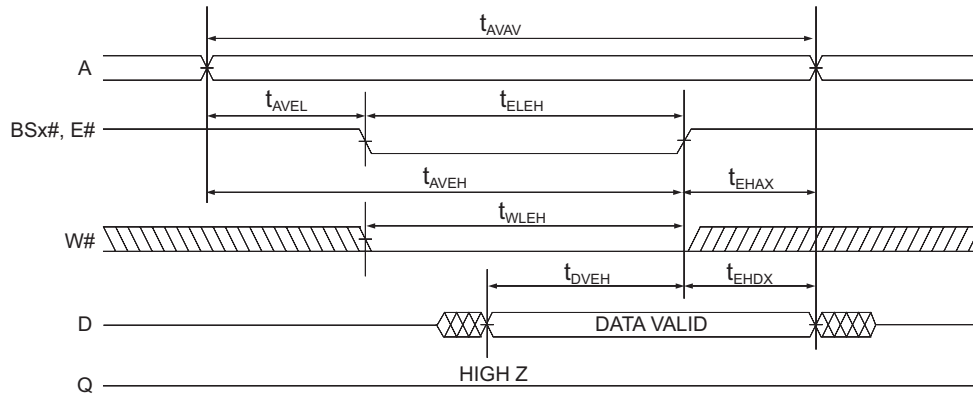
Note 1: Parameter guaranteed, but not tested.

**WRITE CYCLE 1 - W# CONTROLLED**





**WRITE CYCLE 2 - E# CONTROLLED**



**ORDERING INFORMATION**

**Commercial (0°C to 70°C)**

Part Number	Speed (ns)	Package No.
EDI8L32128V12AC	12	99
EDI8L32128V15AC	15	99
EDI8L32128V20AC	20	99

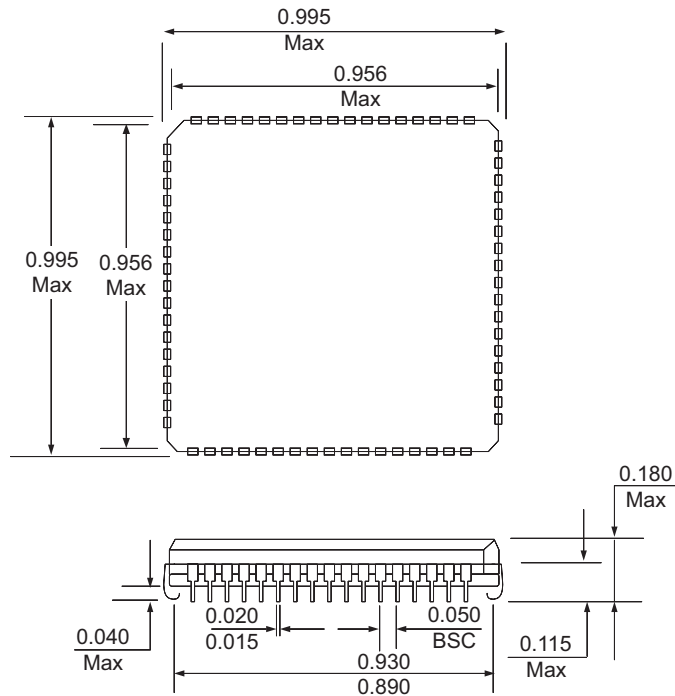
**Industrial (-40°C to +85°C)**

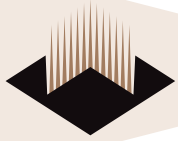
Part Number	Speed (ns)	Package No.
EDI8L32128V12AI	12	99
EDI8L32128V15AI	15	99
EDI8L32128V20AI	20	99

**PACKAGE DESCRIPTION**

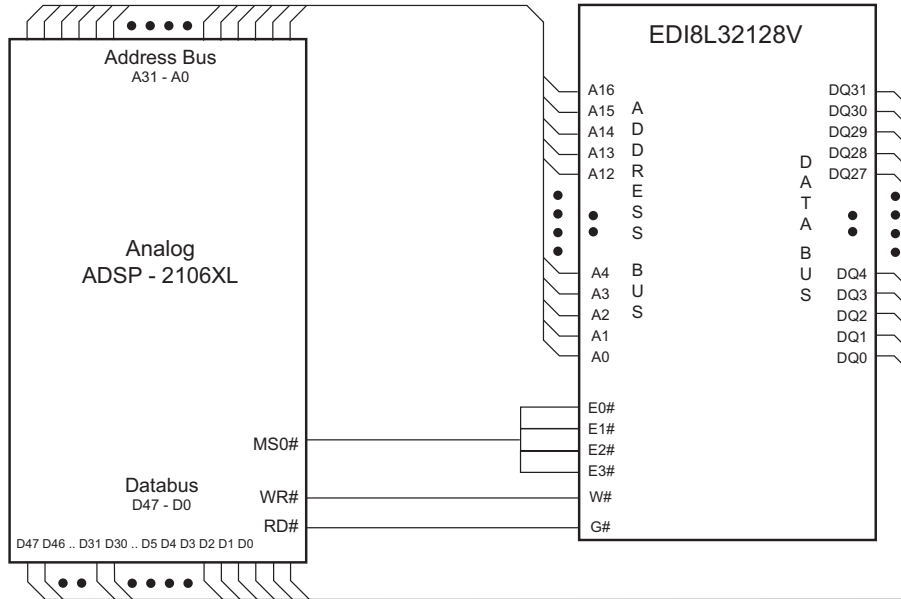
Package No. 99  
68 Lead PLCC  
JEDEC MO-47AE

THETA JA=40°C/W  
THETA Jc=15°C/W  
WEIGHT =4.2G

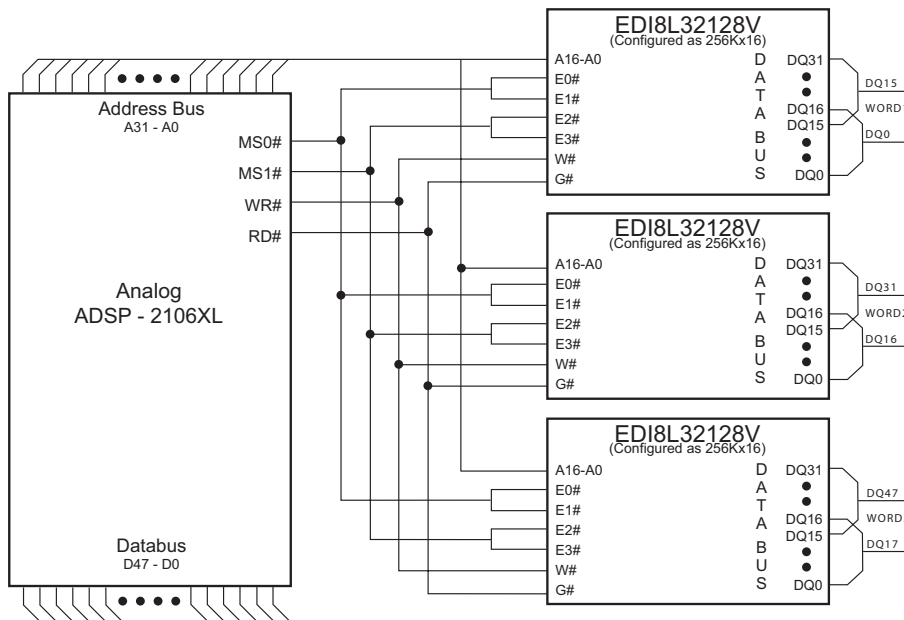


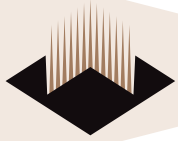


**Figure 1**



**Figure 2**





**Document Title**

128Kx32 CMOS High Speed Static RAM

**Revision History**

<b>Rev #</b>	<b>History</b>	<b>Release Date</b>	<b>Status</b>
Rev 6	6.1 Corrected pin configuration and block diagram on page 1 6.2 Changed pin 64 from "NC" to "A16" 6.3 Added new title page	7-2004	Final