

128Kx32 CMOS High Speed Static RAM

FEATURES

- 128Kx32 bit CMOS Static
- Random Access Memory Array
 - Fast Access Times: 12, 15, 17, 20, and 25ns
 - Individual Byte Enables
 - User Configurable Organization with Minimal Additional Logic
 - Master Output Enable and Write Control
 - TTL Compatible Inputs and Outputs
 - Fully Static, No Clocks
- Surface Mount Package
 - 68 Lead PLCC, No. 99 (JEDEC MO-47AE)
 - Small Footprint, 0.990 Sq. In.
 - Multiple Ground Pins for Maximum Noise Immunity
- Single +5V (±5%) Supply Operation

DESCRIPTION

The EDI8L32128C is a high speed, high performance, four megabit density Static RAM organized as a 128Kx32 bit array.

Four Chip Enables, Write Control, and Output Enable provide the user with a flexible memory solution. The user may independently enable each of the four bytes, and, with minimal additional peripheral logic, the unit may be configured as a 256Kx16 or 512Kx8 array.

Fully asynchronous circuitry is used, requiring no clocks or refreshing for operation and providing equal access and cycle times for ease of use.

The EDI8L32128C, allows 4 megabits of memory to be placed in less than 0.990 square inches of board space; a savings of 0.885 square inches over four standard 128Kx8 components.

NOTE: Solder Reflow temperature should not exceed 230°C

FIG. 1 PIN CONFIGURATION

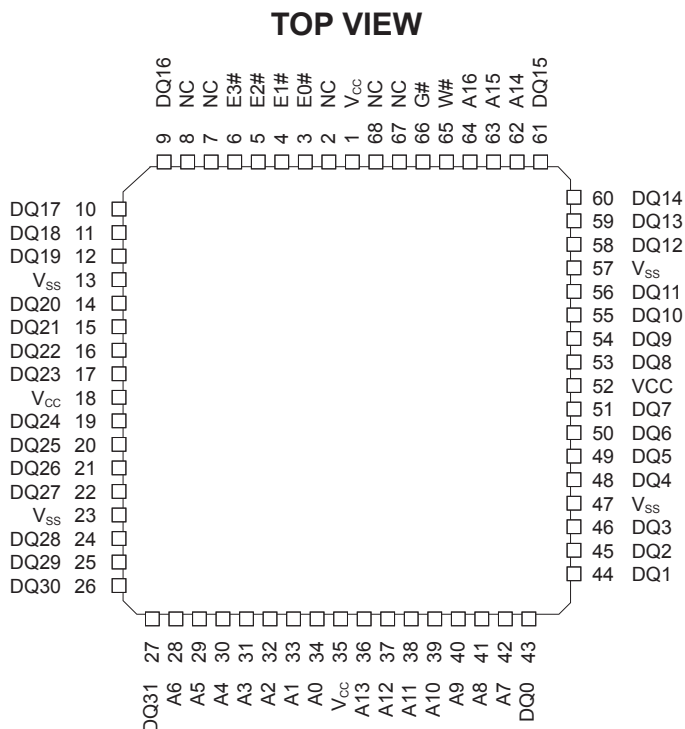

PIN DESCRIPTION

A0-16	Address Inputs
E0-3#	Chip Enables (One per Byte)
W#	Master Write Enable
G#	Master Output Enable
DQ0-31	Common Data Input/Output
V _{cc}	Power (+5V±5%)
V _{ss}	Ground
NC	No Connection

BLOCK DIAGRAM

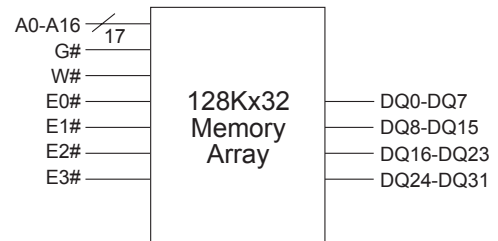

NOTE: Pin 2 & 67 on the 64Kx32 (EDI8L3265C) and the 256Kx32 (EDI8L32256C) are word select pins.

White Electronic Designs Corp. reserves the right to change products or specifications without notice.

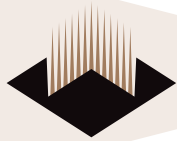

ABSOLUTE MAXIMUM RATINGS*

Voltage on any pin relative to V _{SS}	-0.5V to 7.0V
Operating Temperature T _A (Ambient)	0°C to +70°C
Commercial	0°C to +70°C
Industrial	-40°C to +85°C
Storage Temperature	-55°C to +125°C
Power Dissipation	4 Watts
Output Current	20 mA
Junction Temperature, T _J	175°C

RECOMMENDED DC OPERATING CONDITIONS

Parameter	Sym	Min	Typ	Max	Units
Supply Voltage	V _{CC}	4.75	5.0	5.25	V
Supply Voltage	V _{SS}	0	0	0	V
Input High Voltage	V _{IH}	2.2	--	V _{CC} +0.5	V
Input Low Voltage	V _{IL}	-0.3	--	0.8	V

CAPACITANCE

(f = 1.0MHz, V_{IN} = V_{CC} or V_{SS})

Parameter	Sym	Max	Unit
Address Lines	C _A	40	pF
Data Lines	C _{D/Q}	10	pF
Write & Output Enable Lines	W#, G#	40	pF
Chip Enable Lines/Byte Select	E0-3#	8	pF

*Stress greater than those listed under "Absolute Maximum Ratings" may cause permanent damage to the device. This is a stress rating only and functional operation of the device at these or any other conditions greater than those indicated in the operational sections of this specification is not implied. Exposure to absolute maximum rating conditions for extended periods may affect reliability.

TRUTH TABLE

E#	W#	G#	Mode	Output	Power
H	X	X	Standby	High Z	I _{CC2} , I _{CC3}
L	H	H	Output Disable	High Z	I _{CC1}
L	X	X	Output Disable	High Z	I _{CC1}
L	H	L	Read	D _{OUT}	I _{CC1}
L	L	X	Write	D _{IN}	I _{CC1}

DC ELECTRICAL CHARACTERISTICS

Parameter	Sym	Conditions	Typ	Max				Units
				12*	15	17	20/25	
Operating Power Supply Current	I _{CC1}	W# = V _{IL} , I _{I/O} = 0mA, Min Cycle	620	720	680	640	600	mA
Standby (TTL) Supply Current	I _{CC2}	E# ≥ V _{IH} , V _{IN} ≤ V _{IL} or V _{IN} ≥ V _{IH} , f = 0MHz		160	160	160	160	mA
Full Standby CMOS Supply Current	I _{CC3}	E# ≥ V _{CC} - 0.2V V _{IN} ≥ V _{CC} - 0.2V or V _{IN} ≤ 0.2V		20	20	20	20	mA
Input Leakage Current	I _{LI}	V _{IN} = 0V to V _{CC}				±10		µA
Output Leakage Current	I _{LO}	V I/O = 0V to V _{CC}				±10		µA
Output High Voltage	V _{OH}	I _{OH} = -4.0mA	2.4					V
Output Low Voltage	V _{OL}	I _{OL} = 8.0mA				0.4		V

Typical: T_A = 25°C, V_{CC} = 5.0V

AC TEST CONDITIONS

Figure 2

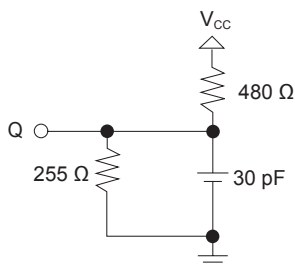
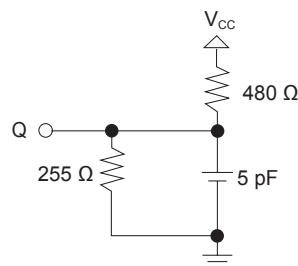

Figure 3



Input Pulse Levels	V _{SS} to 3.0V
Input Rise and Fall Times	5ns
Input and Output Timing Levels	1.5V
Output Load	Figure 2

NOTE: For t_{EH0Z}, t_{GH0Z} and t_{wL0Z}, CL = 5pF Figure 3)



AC CHARACTERISTICS - READ CYCLE

Parameter	Symbol		12ns		15ns		17ns		20ns		25n		Units
	JEDEC	Alt.	Min	Max	Min	Max	Min	Max	Min	Max	Min	Max	
Read Cycle Time	t _{AVAV}	t _{RC}	12		15		17		20		25		ns
Address Access Time	t _{AVQV}	t _{AA}		12		15		17		20		25	ns
Chip Enable Access Time	t _{ELQV}	t _{ACS}		12		15		17		20		25	ns
Chip Enable to Output in Low Z (1)	t _{ELQX}	t _{CLZ}	2		3		3		3		3		ns
Chip Disable to Output in High Z (1)	t _{EHQZ}	t _{CHZ}		7		8		8		10		10	ns
Output Hold from Address Change	t _{AVQX}	t _{OH}	3		3		3		3		3		ns
Output Enable to Output Valid	t _{GLQV}	t _{OE}		5		6		8		8		10	ns
Output Enable to Output in Low Z (1)	t _{GLQX}	t _{OLZ}	2		2		2		2		0		ns
Output Disable to Output in High Z(1)	t _{GHQZ}	t _{OHZ}		4		5		6		8		10	ns

NOTE 1: Parameter guaranteed, but not tested.

FIG. 4 READ CYCLE 1 - W# HIGH, G#, E# LOW

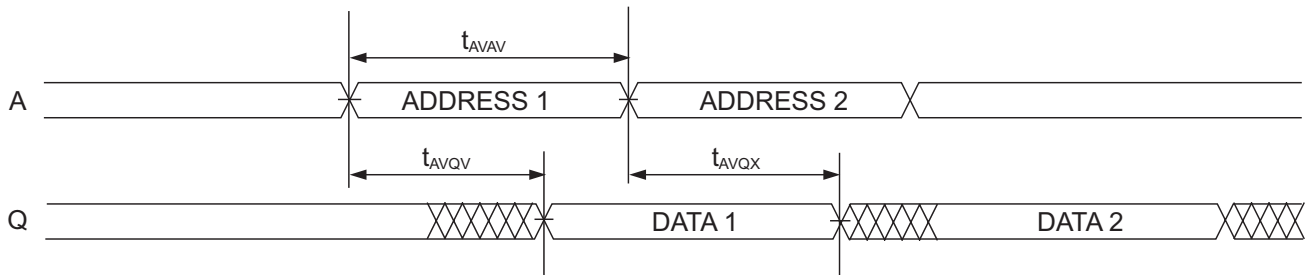
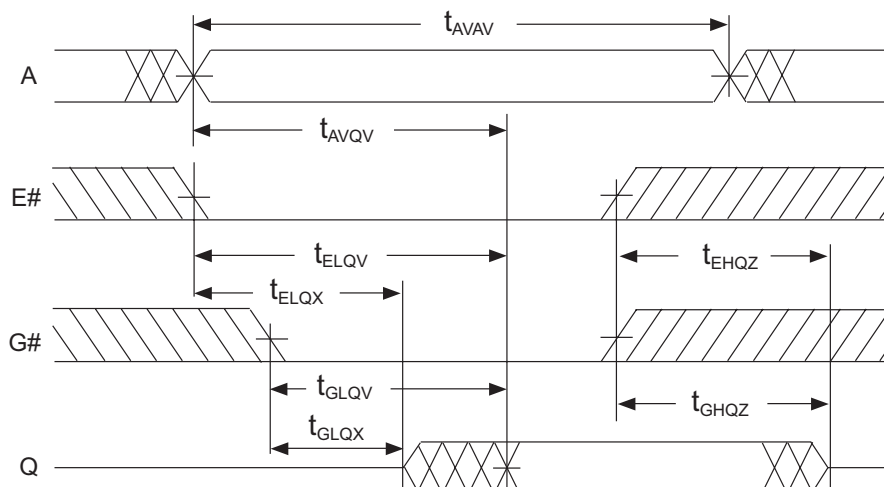
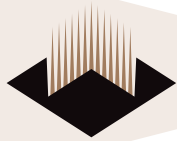

FIG. 5 READ CYCLE 2 - W# HIGH





AC CHARACTERISTICS - WRITE CYCLE

Parameter	Symbol		12ns		15ns		17ns		20ns		25ns		Units
	JEDEC	Alt.	Min	Max	Min	Max	Min	Max	Min	Max	Min	Max	
Write Cycle Time	t_{AVAV}	t_{WC}	12		15		17		20		25		ns
Chip Enable to End of Write	t_{ELWH}	t_{CW}	8		9		10		15		20		ns
	t_{ELEH}	t_{CW}	8		9		10		15		20		ns
Address Setup Time	t_{AVWL}	t_{AS}	0		0		0		0		0		ns
	t_{AVEL}	t_{AS}	0		0		0		0		0		ns
Address Valid to End of Write	t_{AVWH}	t_{AW}	9		10		12		15		15		ns
	t_{AVEH}	t_{AW}	9		10		12		15		15		ns
Write Pulse Width	t_{WLWH}	t_{WP}	9		10		12		15		15		ns
	t_{WLEH}	t_{WP}	9		10		12		15		15		ns
Write Recovery Time	t_{WHAX}	t_{WR}	0		0		0		0		0		ns
	t_{EHAX}	t_{WR}	0		0		0		0		0		ns
Data Hold Time	t_{WHDX}	t_{DH}	0		0		0		0		0		ns
	t_{EHDX}	t_{DH}	0		0		0		0		0		ns
Write to Output in High Z (1)	t_{WLOZ}	t_{WHZ}	0	5	0	6	0	7	0	7	0	10	ns
Data to Write Time	t_{DVWH}	t_{DW}	5		6		8		8		12		ns
	t_{DVEH}	t_{DW}	5		6		8		8		12		ns
Output Active from End of Write (1)	t_{WHQX}	t_{WLZ}	2		2		2		2		2		ns

NOTE: Parameter guaranteed, but not tested.

FIG. 6 WRITE CYCLE 1 - W# CONTROLLED

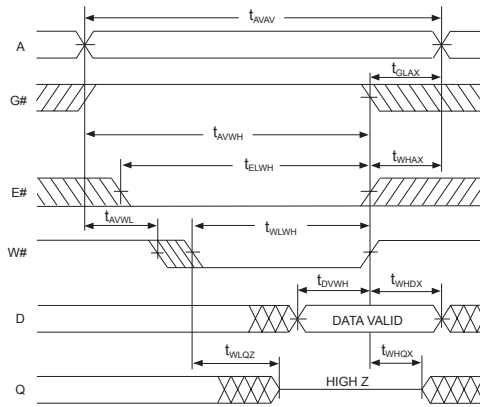
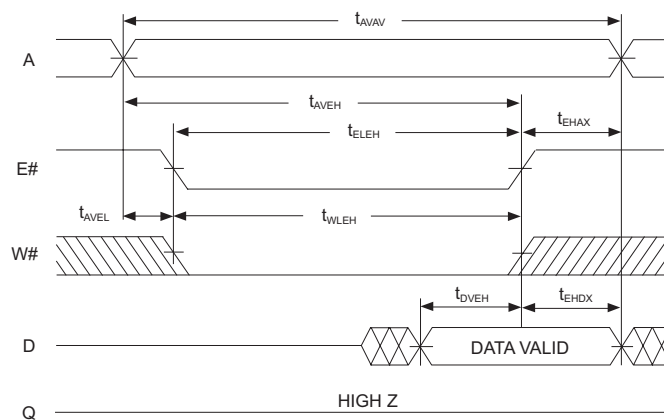

FIG. 7 WRITE CYCLE 2 - E# CONTROLLED



White Electronic Designs Corp. reserves the right to change products or specifications without notice.



PACKAGE DESCRIPTION

Package No. 99: 68 LEAD PLCC
JEDEC MO-47AE

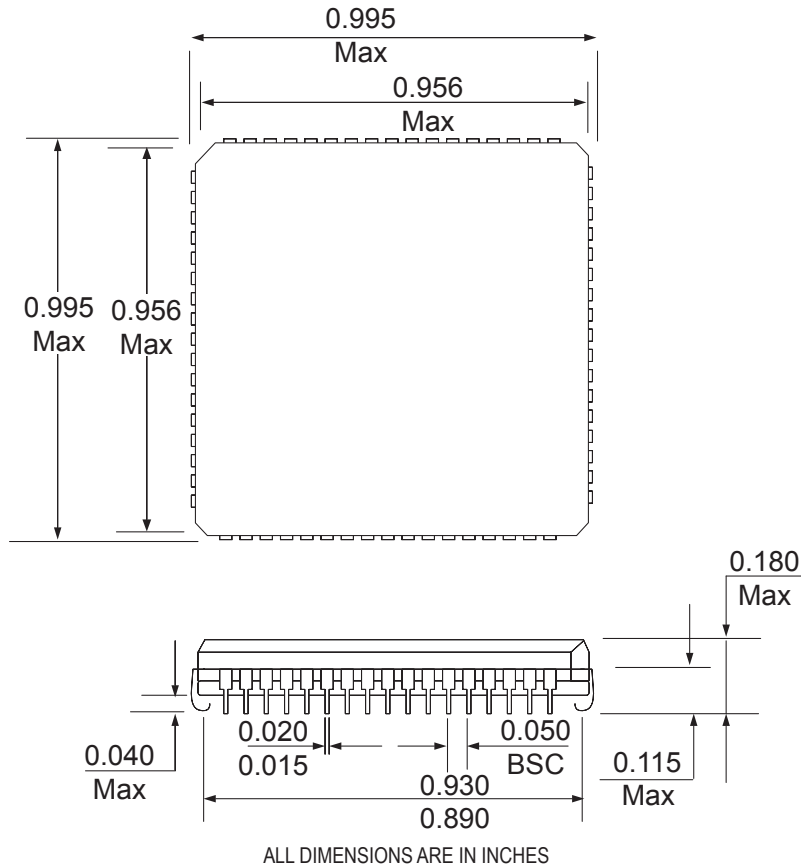

ORDERING INFORMATION

Commercial (0°C to +70°C)

Part Number	Speed (ns)	Package No.
EDI8L32128C12AC	12	99
EDI8L32128C15AC	15	99
EDI8L32128C17AC	17	99
EDI8L32128C20AC	20	99
EDI8L32128C25AC	25	99

Industrial (-40°C to +85°C)

Part Number	Speed (ns)	Package No.
EDI8L32128C15AI	15	99
EDI8L32128C17AI	17	99
EDI8L32128C20AI	20	99